

# ASSEMBLY INSTRUCTIONS



*Fine Furniture for every stage of life*

## Queen Storage Bed

REVISION 0: 06/10/2018  
REVISION 1: 04/22/2019  
REVISION 2: 08/27/2019  
REVISION 3: 01/11/2021

# ASSEMBLY INSTRUCTIONS

## ASSEMBLY TIPS:

1. Remove hardware from box and sort by size.
2. Please check to see that all hardware and parts are present prior to start of assembly.
3. Please follow attached instructions in the same sequence as numbered to assure fast & easy assembly.



### WARNING!

1. Don't attempt to repair or modify parts that are broken or defective. Please contact the store immediately.
2. This product is for home use only and not intended for commercial establishments.

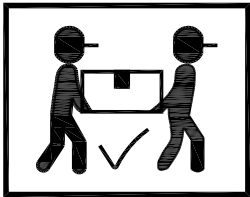

**ASSEMBLY TIME**

**30 MINUTES**

## PARTS IDENTIFICATION

### B1 ( BOX 1 )

A HEADBOARD PANEL

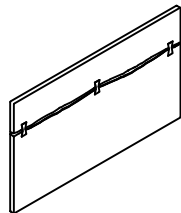

1PC

B HEADBOARD LEG

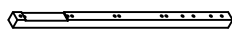

2PCS

C CENTER RAIL SUPPORT



1PC

### B2 ( BOX 2 )

D FOOTBOARD

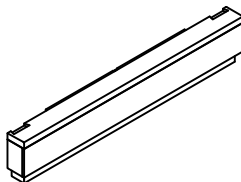

1PC

### B3 ( BOX 3 )

E RIGHT STORAGE SIDE RAIL

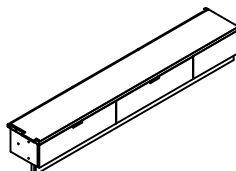

1PC

F LEFT STORAGE SIDE RAIL

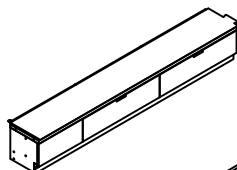

1PC

G TRESTLE BAR



1PC

H CENTER RAIL

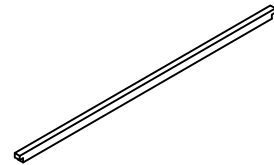

1PC

I ROLL SLAT ( 13PCS )

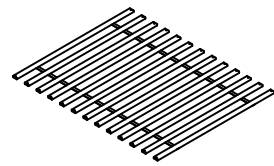

1SET

J CENTER RAIL SUPPORT WITH LEVELER



3PCS

K CONCEAL PANEL

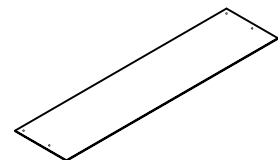

1PC

L DRAWER SUPPORT LEG WITHOUT LEVELER



4PCS

HB HEADBOARD COMPLETE

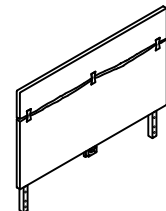

1PC

D FOOTBOARD

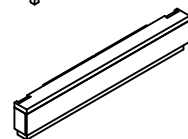

1PC

### NOTE :

Phillips head screw driver is required in the assembly process; however, manufacturer does not provide this item.

# ASSEMBLY INSTRUCTIONS

## ASSEMBLY TIPS:

1. Remove hardware from box and sort by size.
2. Please check to see that all hardware and parts are present prior to start of assembly.
3. Please follow attached instructions in the same sequence as numbered to assure fast & easy assembly.









### WARNING!



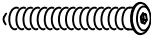
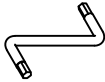





1. Don't attempt to repair or modify parts that are broken or defective. Please contact the store immediately.
2. This product is for home use only and not intended for commercial establishments.

## HARDWARE IDENTIFICATION

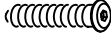
### B1 ( BOX 1 ) - HARDWARE PACK IS LOCATED IN (B1)

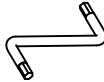
1	<b>SHORT BOLT</b> ( M6 x 40mm - BLK )		2PCS	5	<b>BIG FLAT WASHER</b> ( Ø20 x Ø8 x 2mm - BLK )		8PCS
2	<b>LONG BOLT</b> ( M8 x 60mm - BLK )		8PCS	6	<b>Z-ALLEN WRENCH</b> ( 4mm - WHT )		1PC
3	<b>LOCK WASHER</b> ( Ø13 x Ø8 x 2mm - BLK )		10PCS	7	<b>ALLEN WRENCH</b> ( 5mm - BLK )		1PC
4	<b>SMALL FLAT WASHER</b> ( Ø16 x Ø6.5 x 1mm - BLK )		2PCS				

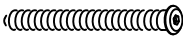
### B3 ( BOX 3 ) - HARDWARE PACK IS LOCATED IN (B3)

8	<b>BOLT 1</b> ( M8 x 20mm - BLK )		2PCS	14	<b>BIG FLAT WASHER</b> ( Ø20 x Ø8 x 2mm - BLK )		16PCS
9	<b>BOLT 2</b> ( M8 x 40mm - BLK )		4PCS	15	<b>SMALL FLAT WASHER</b> ( Ø16 x Ø6.5 x 1mm - BLK )		2PCS
10	<b>BOLT 3</b> ( M6 x 50mm - BLK )		2PCS	16	<b>Z-ALLEN WRENCH</b> ( 4mm - WHT )		1PC
11	<b>BOLT 4</b> ( M8 x 50mm - BLK )		6PCS	17	<b>ALLEN WRENCH</b> ( 5mm - BLK )		1PC
12	<b>BOLT 5</b> ( M8 x 60mm - BLK )		4PCS	18	<b>LONG PAN HEAD SCREW</b> ( Ø7 x Ø1 1/4" - BLK )		26PCS
13	<b>LOCK WASHER</b> ( Ø13 x Ø8 x 2mm - BLK )		18PCS	19	<b>SHORT PAN HEAD SCREW</b> ( Ø6 x Ø5/8" - BLK )		4PCS

### NOTE :

Phillips head screw driver is required in the assembly process; however, manufacturer does not provide this item.

# ASSEMBLY INSTRUCTIONS

## STEP 1

X - DONT USE , ✓ - USED

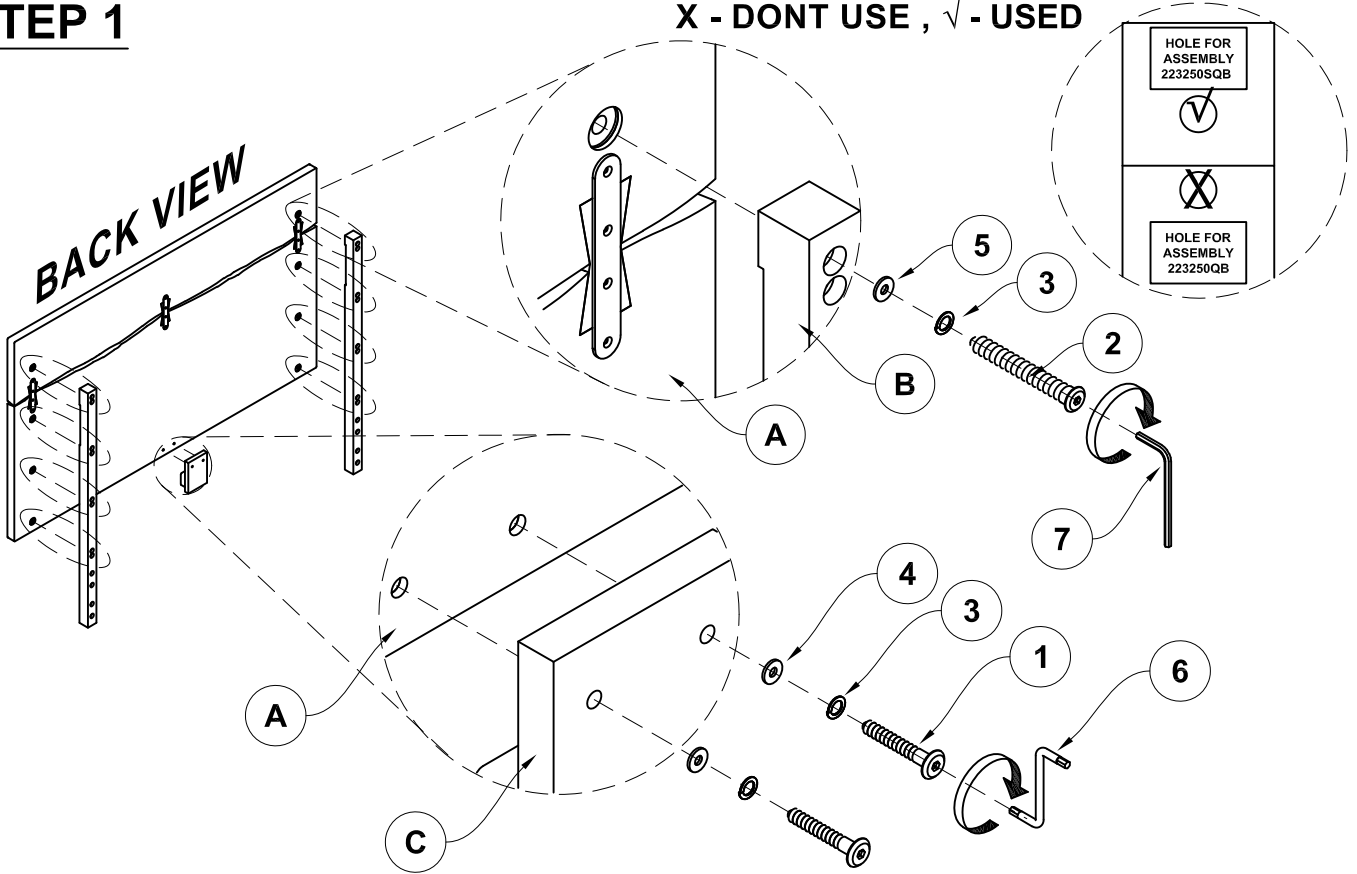

## STEP 2

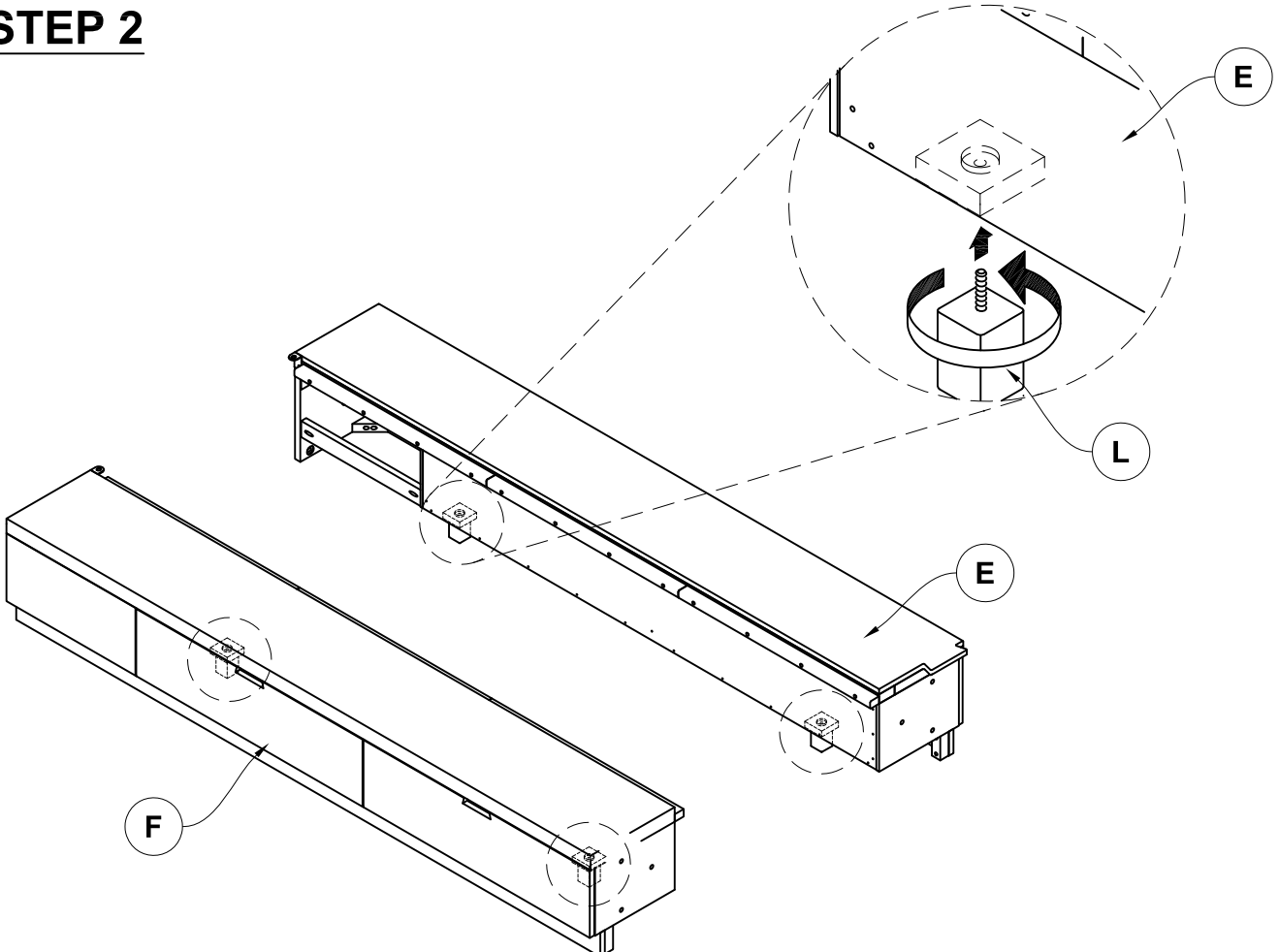

# ASSEMBLY INSTRUCTIONS

## STEP 3

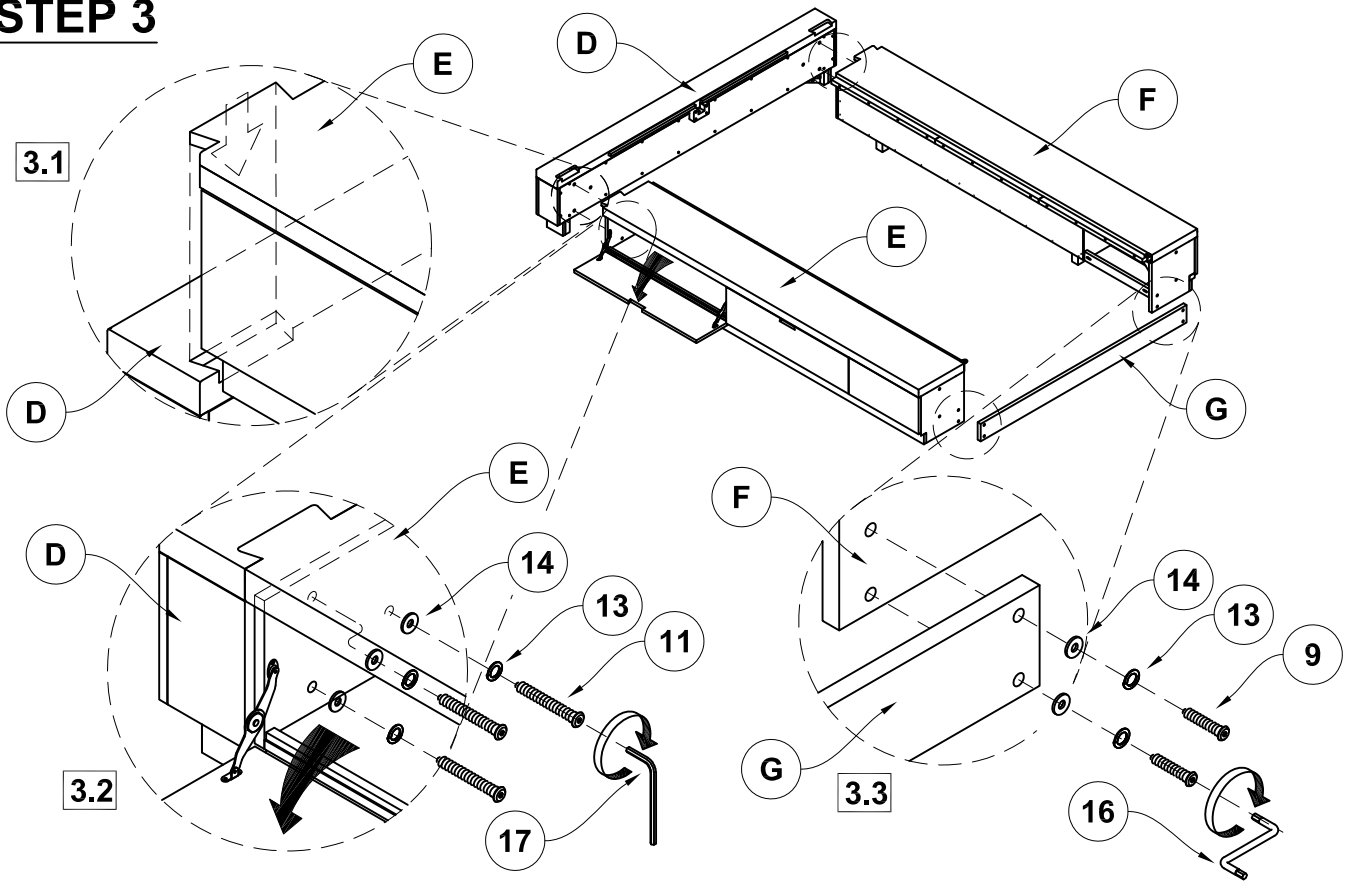

## STEP 4

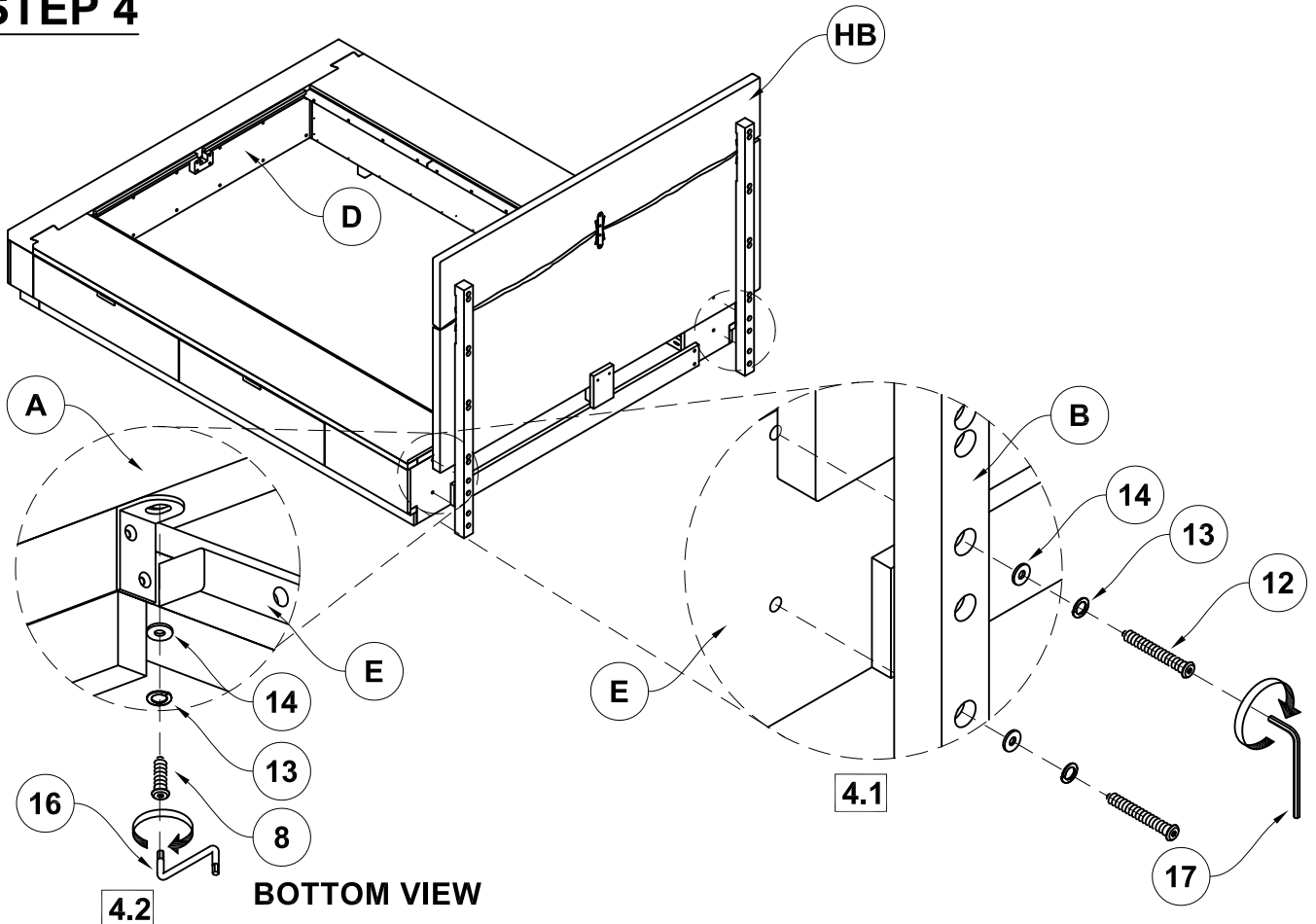

# ASSEMBLY INSTRUCTIONS

## STEP 5

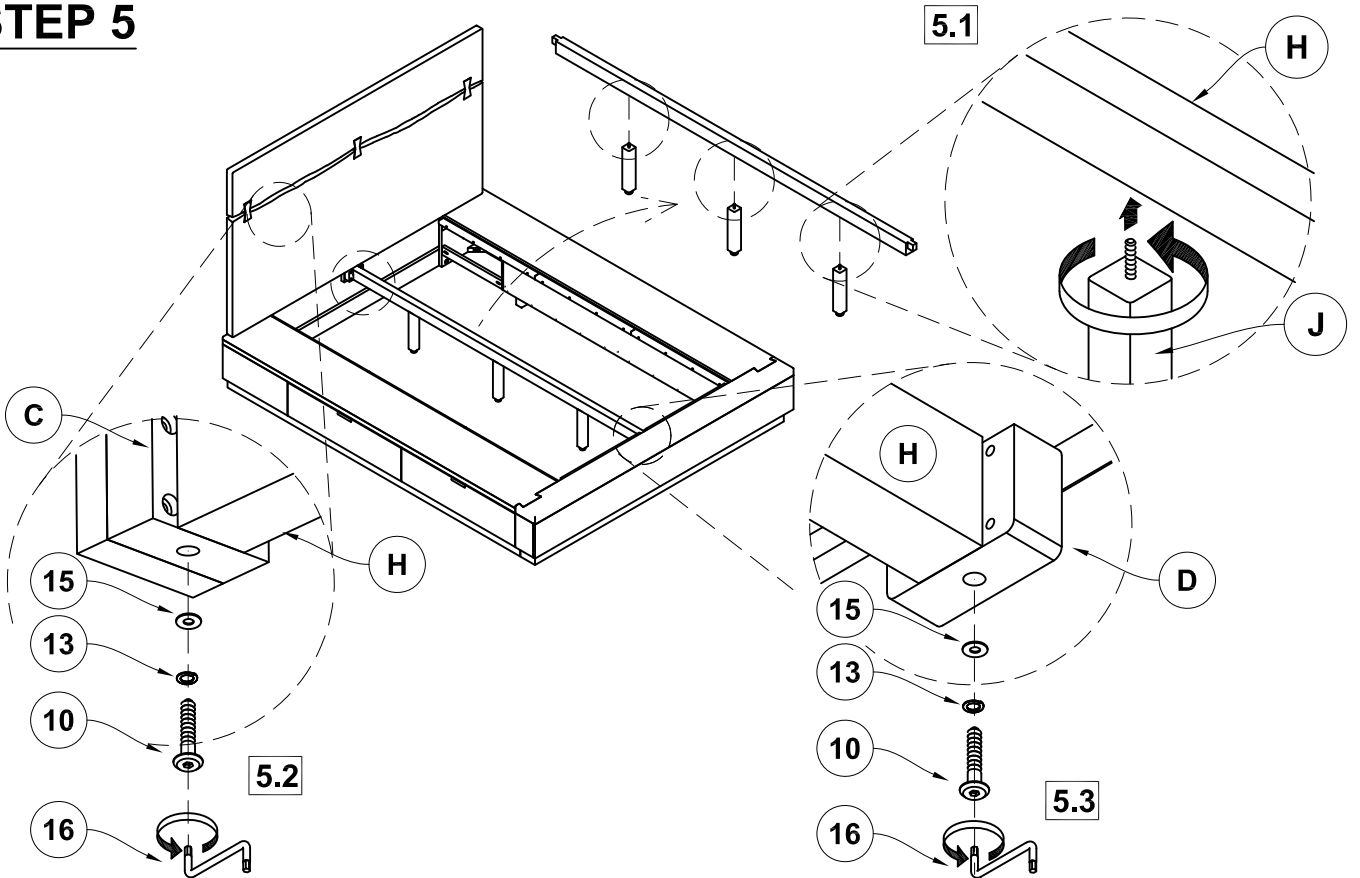

## STEP 6

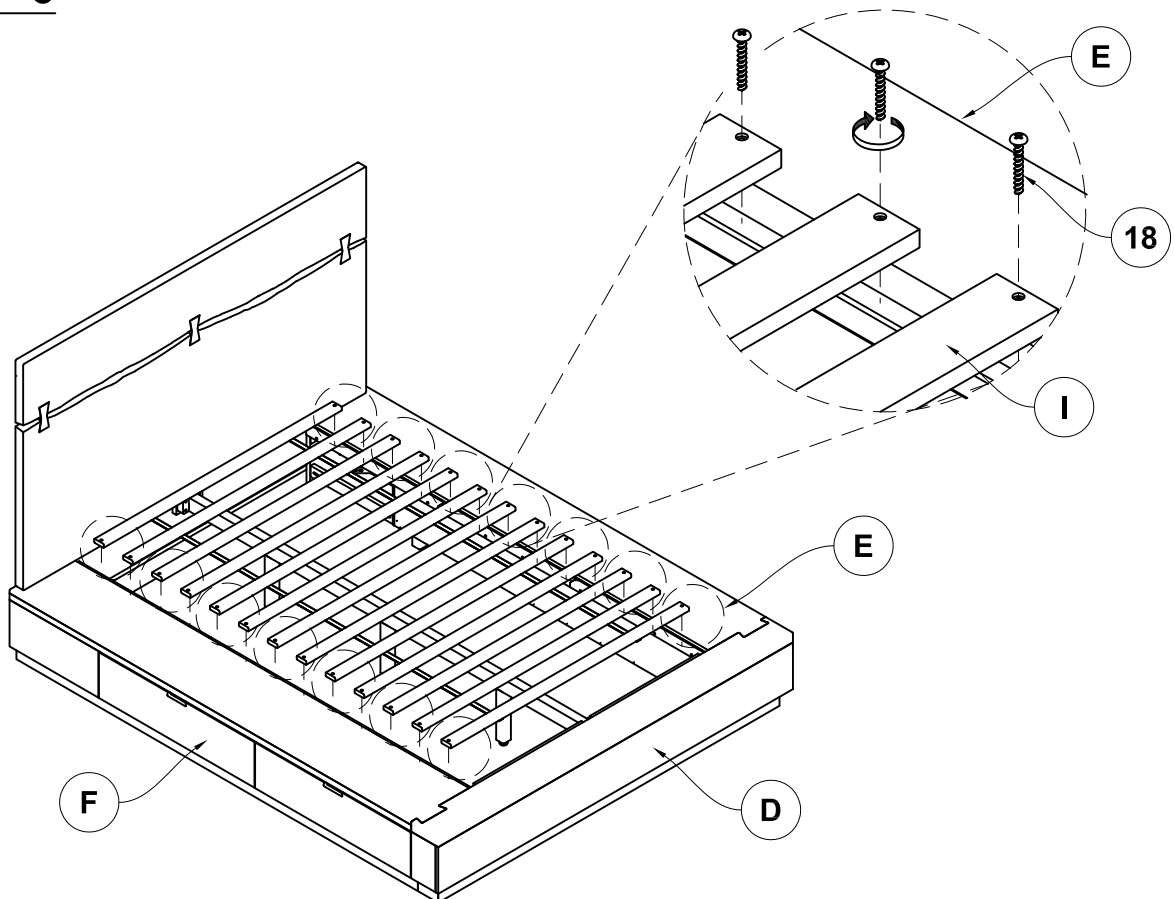

# ASSEMBLY INSTRUCTIONS

## STEP 7

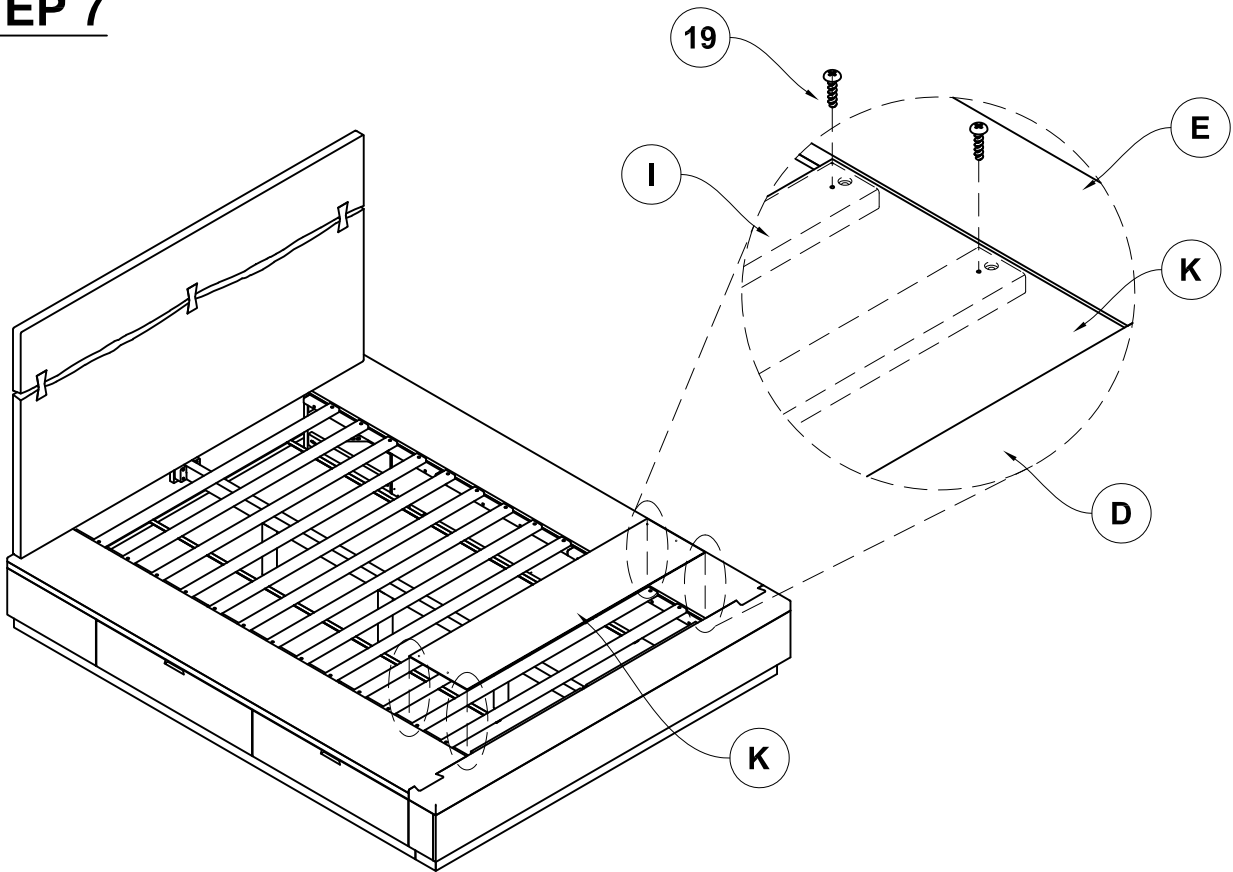

## STEP 8 COMPLETE

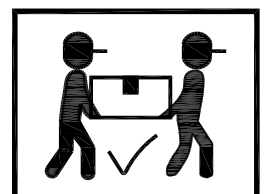
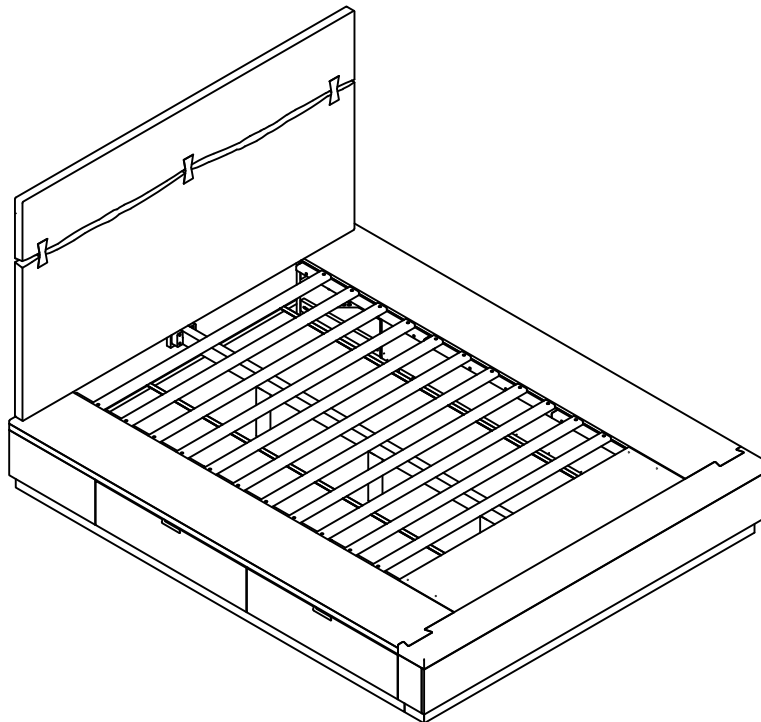

Inner Size: 72.50"W X 86.00"D

Open Cubby A : 31.75"W X 10.50"D X 7.50"H X 0.50"T

Open Cubby B : 31.00"W X 10.50"D X 7.50"H X 0.50"T

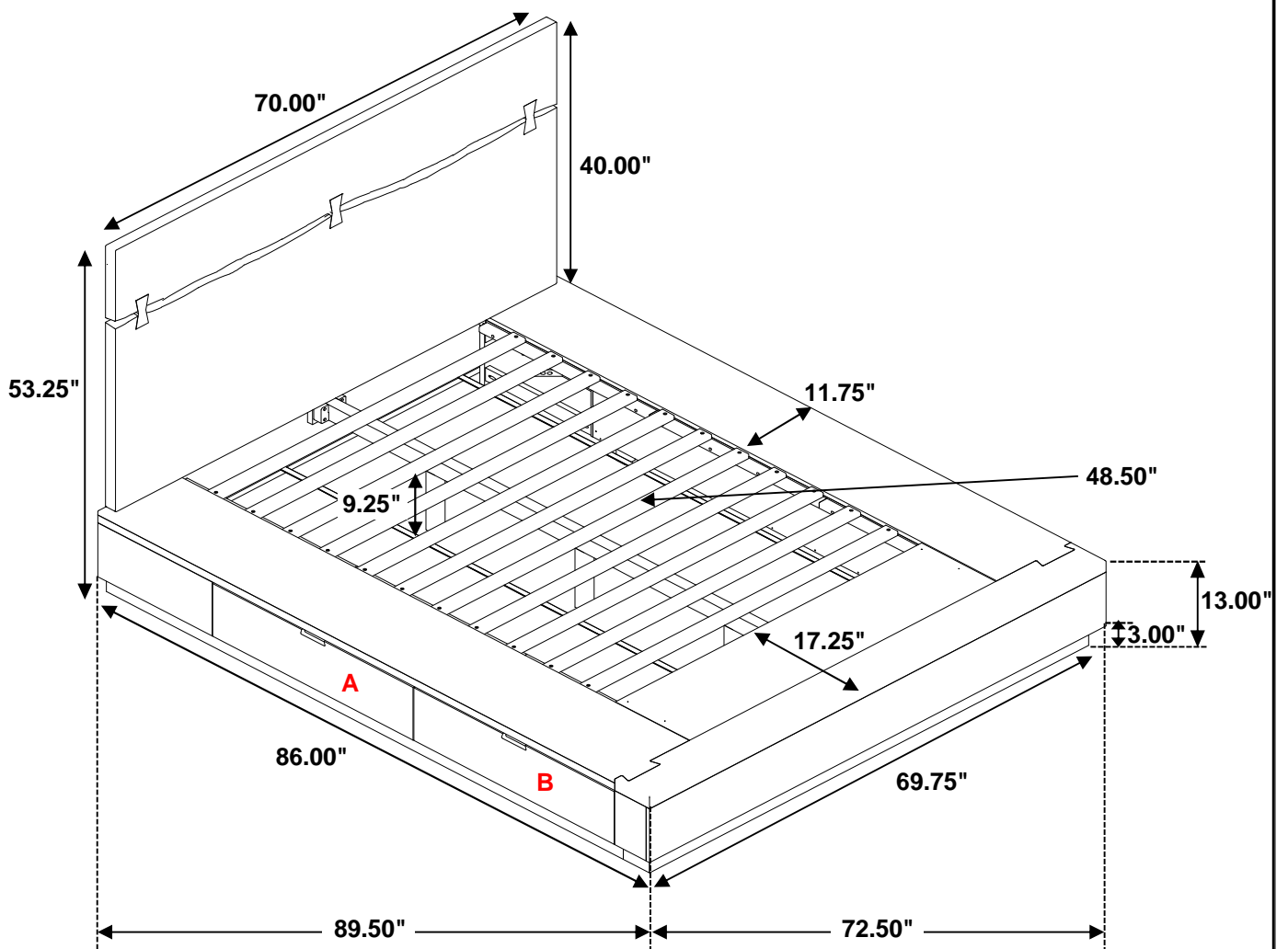

Note: Dimension tolerance  $\pm 5\%$