

Version: 2.1

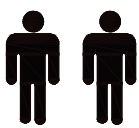

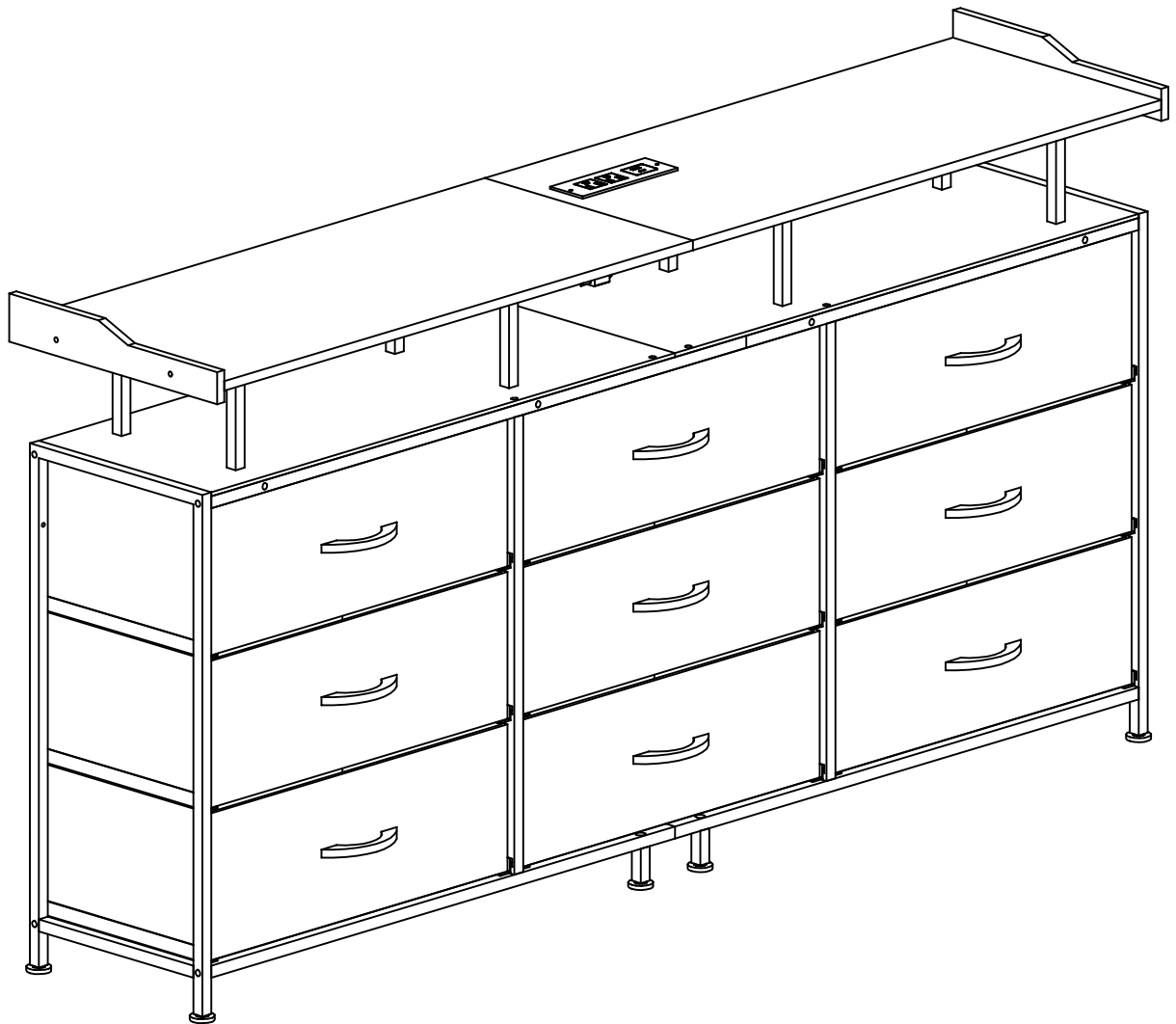

2 PERS.

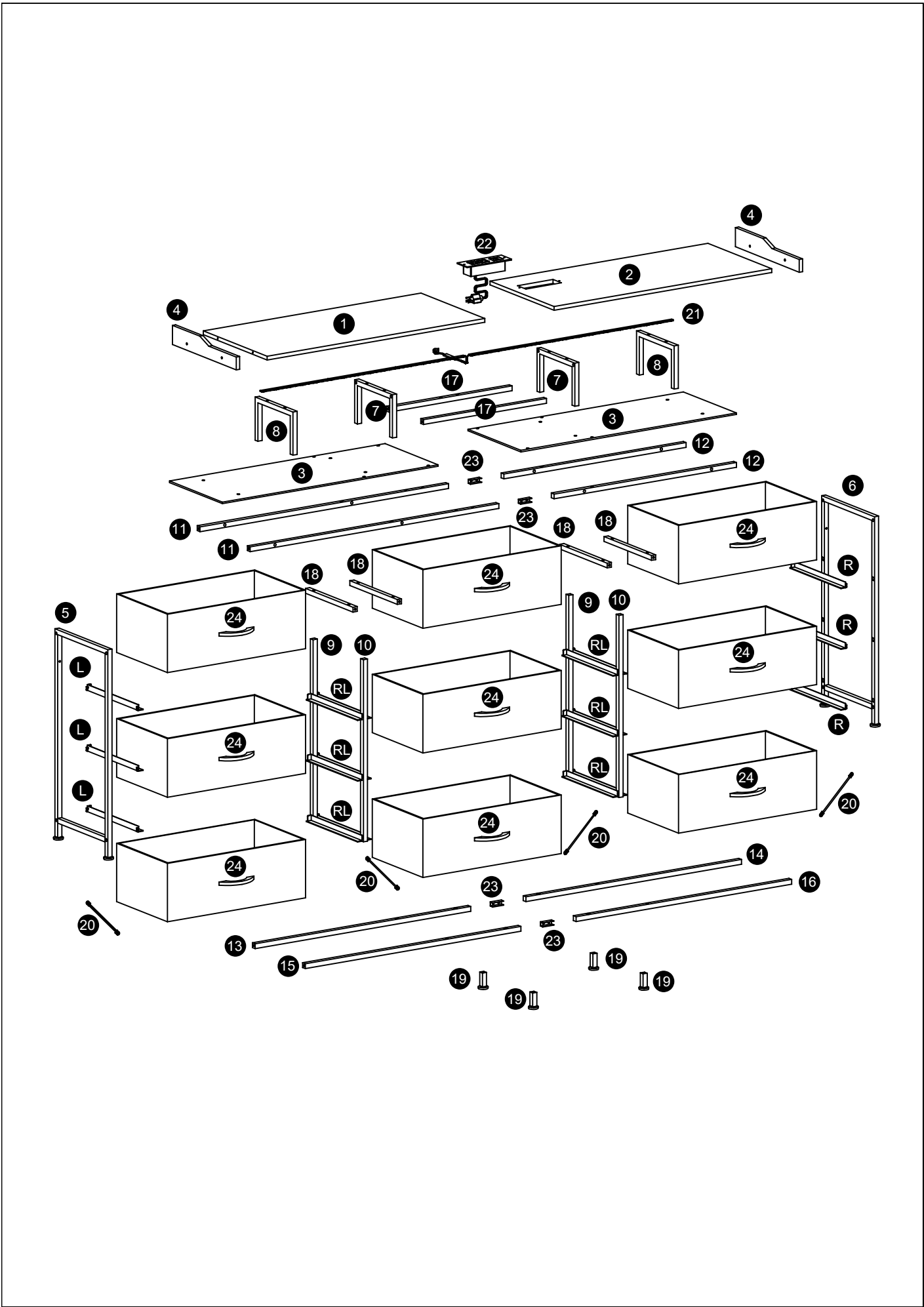





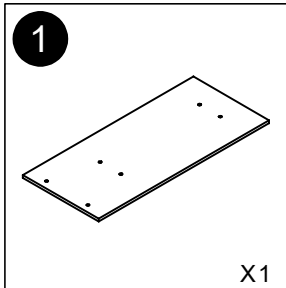
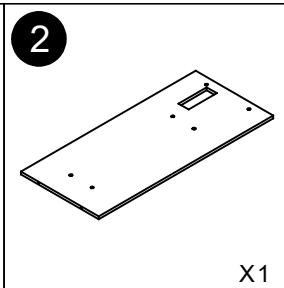
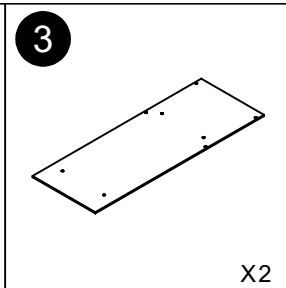
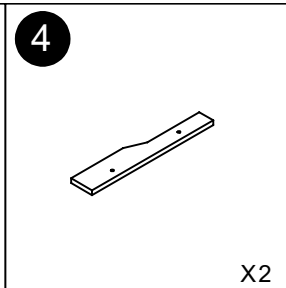
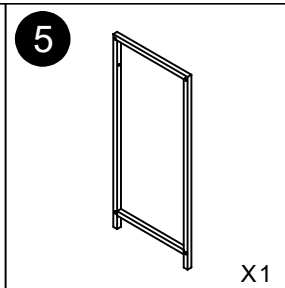
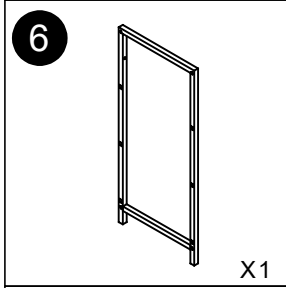
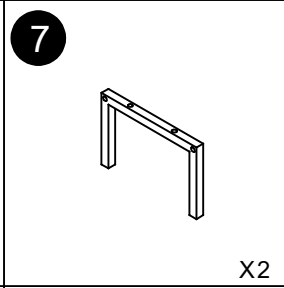
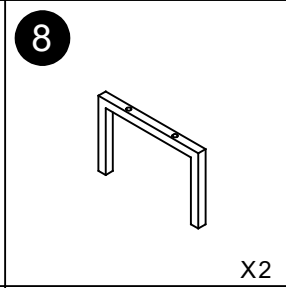
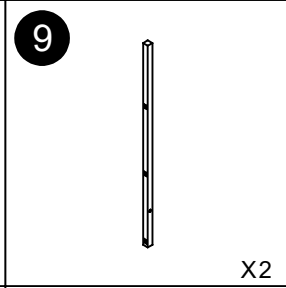
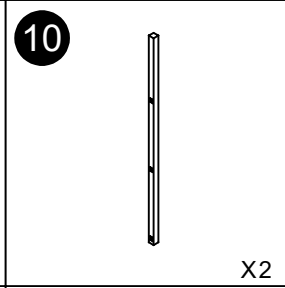
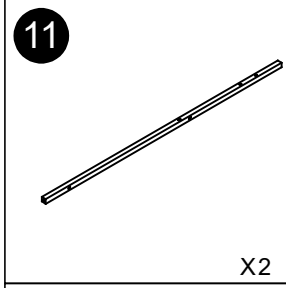
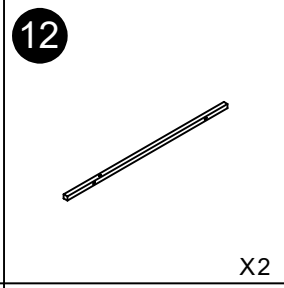
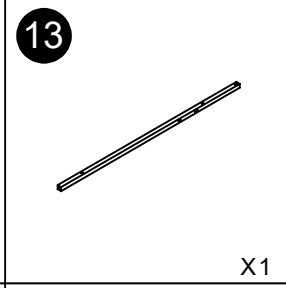
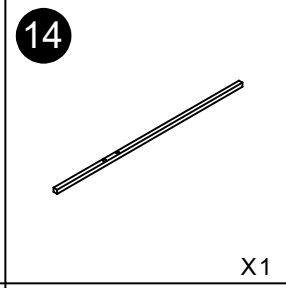
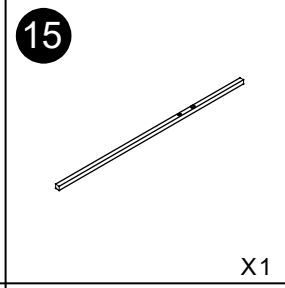
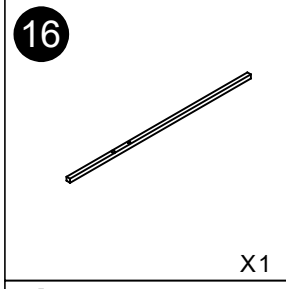
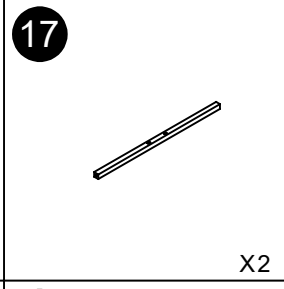
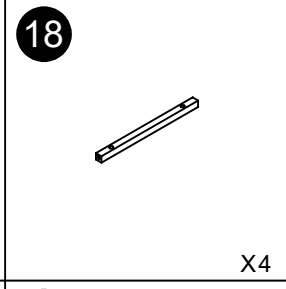
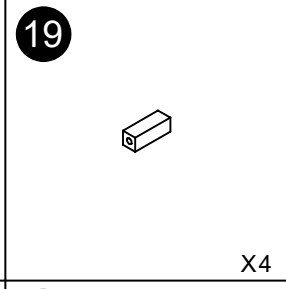
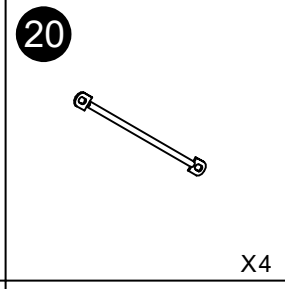
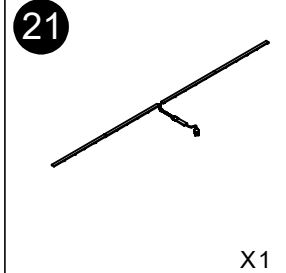

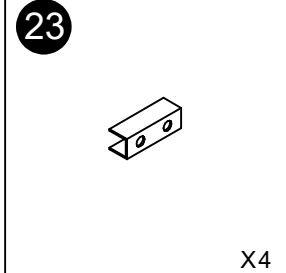
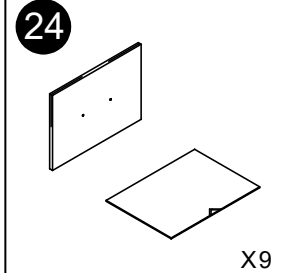



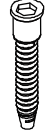



Assembling Instruction

Attention: Do not tighten the screws until all of them are in right positions

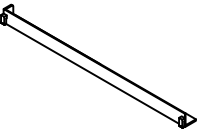
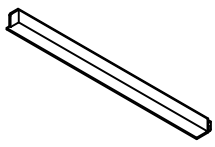
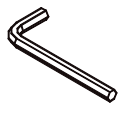
 <p>1</p> <p>X1</p>	 <p>2</p> <p>X1</p>	 <p>3</p> <p>X2</p>	 <p>4</p> <p>X2</p>	 <p>5</p> <p>X1</p>
 <p>6</p> <p>X1</p>	 <p>7</p> <p>X2</p>	 <p>8</p> <p>X2</p>	 <p>9</p> <p>X2</p>	 <p>10</p> <p>X2</p>
 <p>11</p> <p>X2</p>	 <p>12</p> <p>X2</p>	 <p>13</p> <p>X1</p>	 <p>14</p> <p>X1</p>	 <p>15</p> <p>X1</p>
 <p>16</p> <p>X1</p>	 <p>17</p> <p>X2</p>	 <p>18</p> <p>X4</p>	 <p>19</p> <p>X4</p>	 <p>20</p> <p>X4</p>
 <p>21</p> <p>X1</p>	 <p>22</p> <p>X1</p>	 <p>23</p> <p>X4</p>	 <p>24</p> <p>X9</p>	

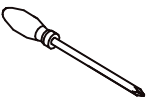
<p>A</p>  <p>M6X12 X20</p>	<p>B</p>  <p>M6X22 X40</p>	<p>C</p>  <p>M6X28 X12</p>	<p>D</p>  <p>M5X40 X4</p>	<p>E</p>  <p>M4X10 X18</p>
<p>F</p>  <p>M4X12 X2</p>	<p>G</p>  <p>M6 X8</p>	<p>H</p>  <p>X9</p>	<p>J</p> <div data-bbox="1037 425 1189 604" style="border: 1px solid black; padding: 5px;">  <p>M6X30</p>  <p>M4X70</p> </div> <p>X2</p>	<p>K</p> <div data-bbox="1340 425 1492 604" style="border: 1px solid black; padding: 5px;">   <p>M3X12</p> </div> <p>X4</p>
<p>L</p>  <p>X9</p>	<p>R</p>  <p>X9</p>	 <p>M4</p>	 <p>M3</p>	

Step 1

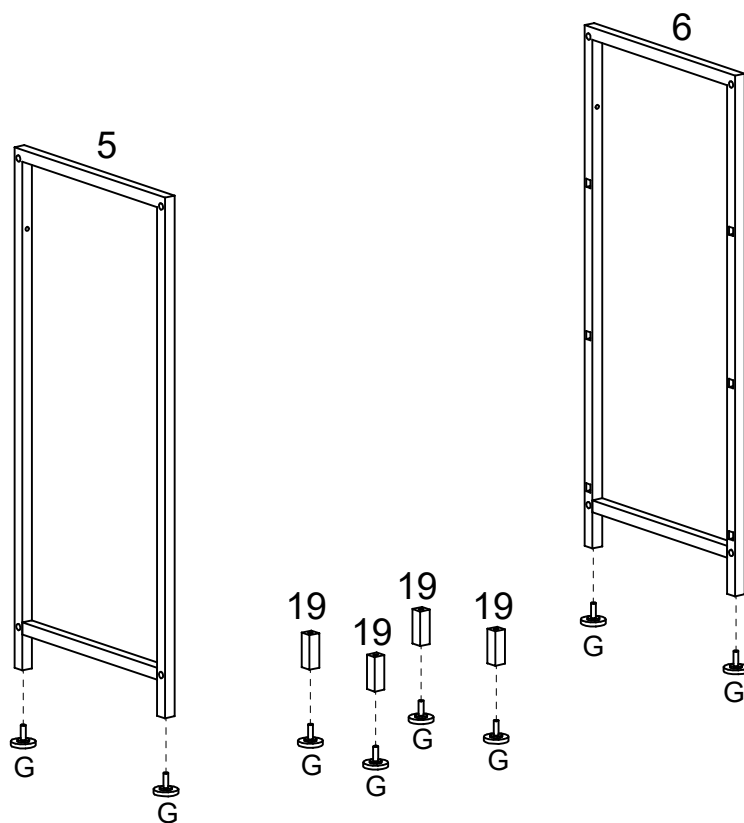

G	M6	X8
---	----	----

Step 2

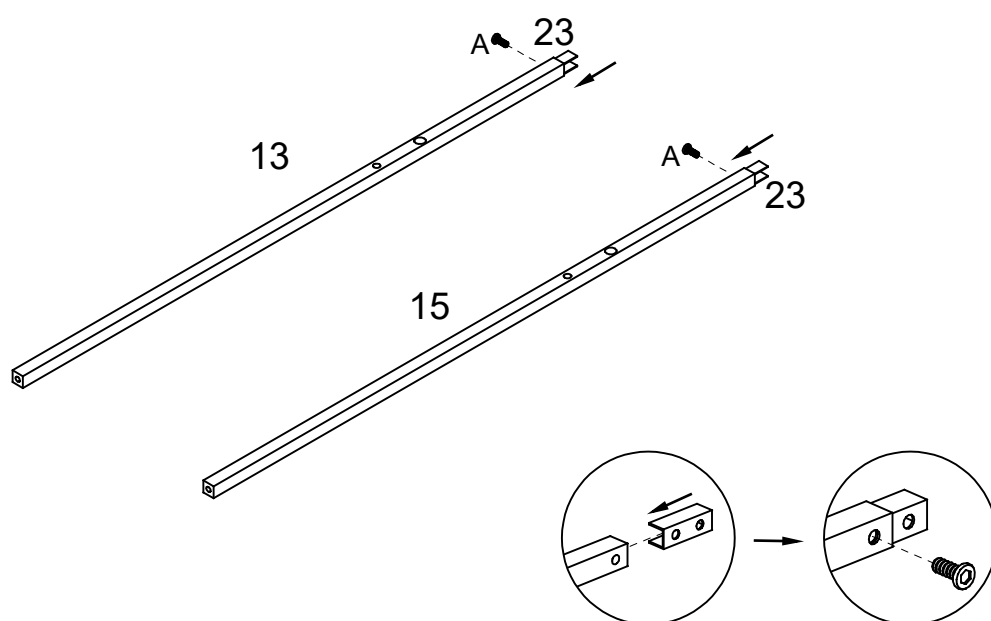

A	M6X12	X2
---	-------	----

Step 3

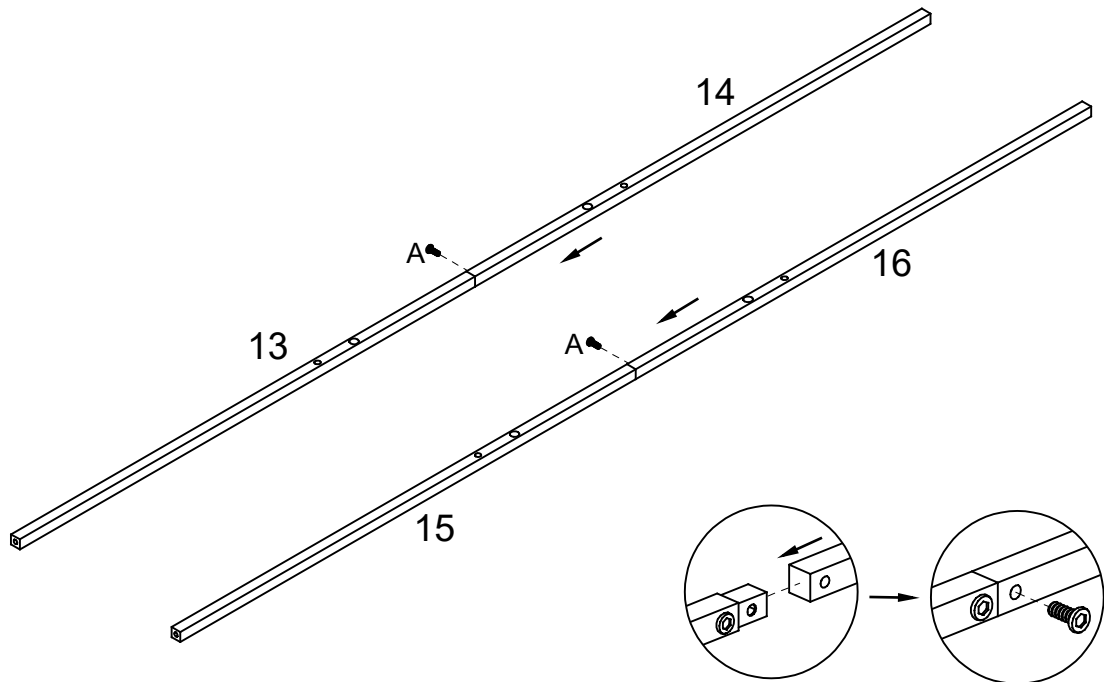

A M6X12 X2

Step 4

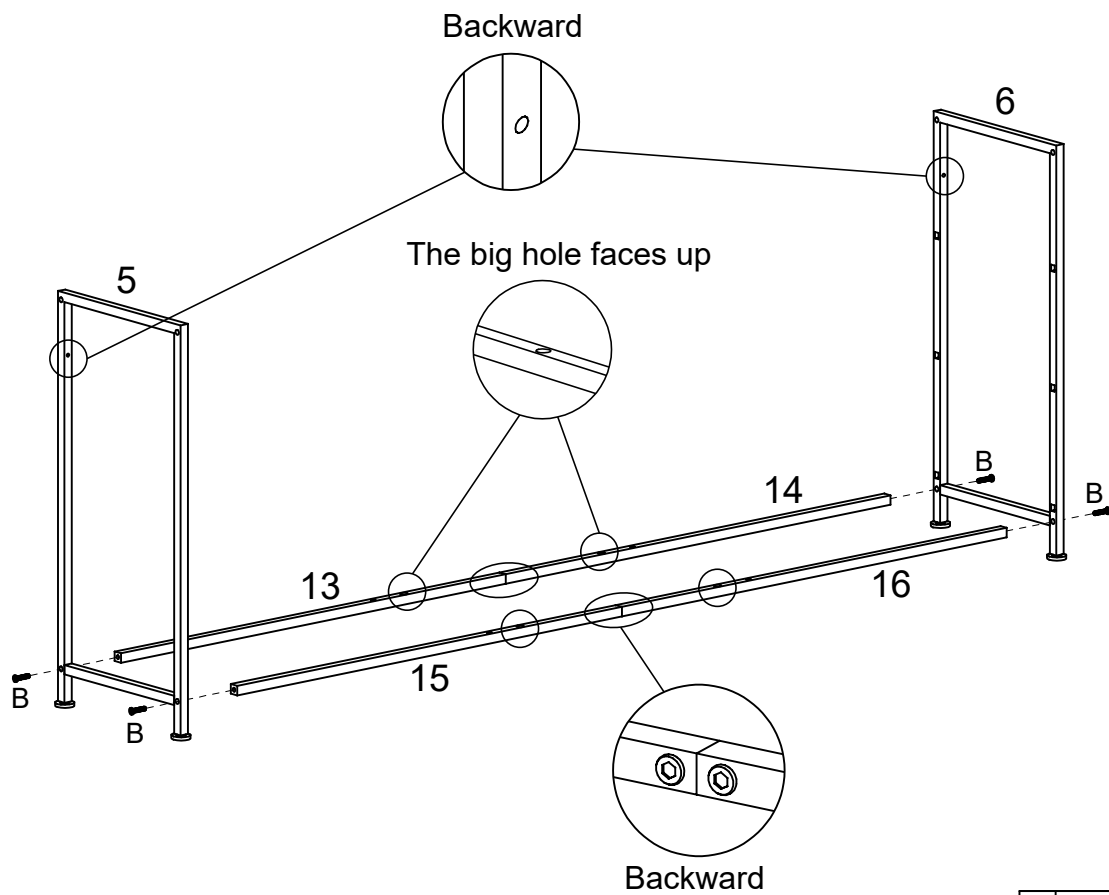

B M6X22 X4

Step 5

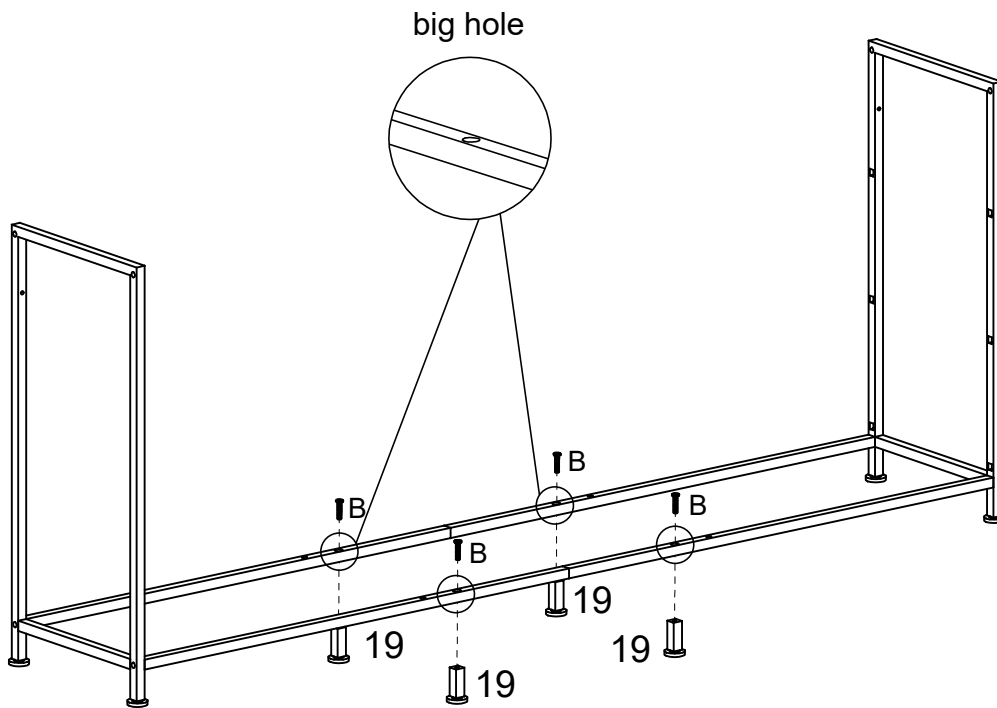

B M6X22 X4

Step 6

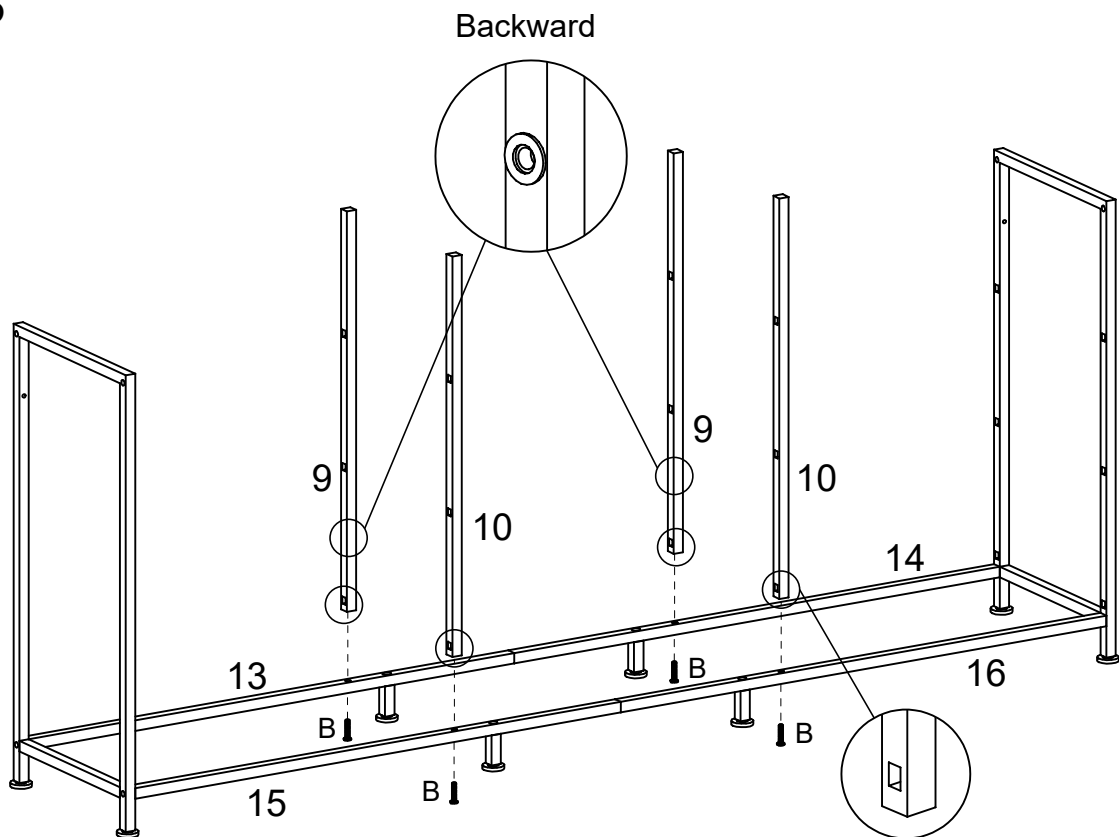

The rectangular hole closer to the edge of the steel pipe faces downwards.

B M6X22 X4

Step 7

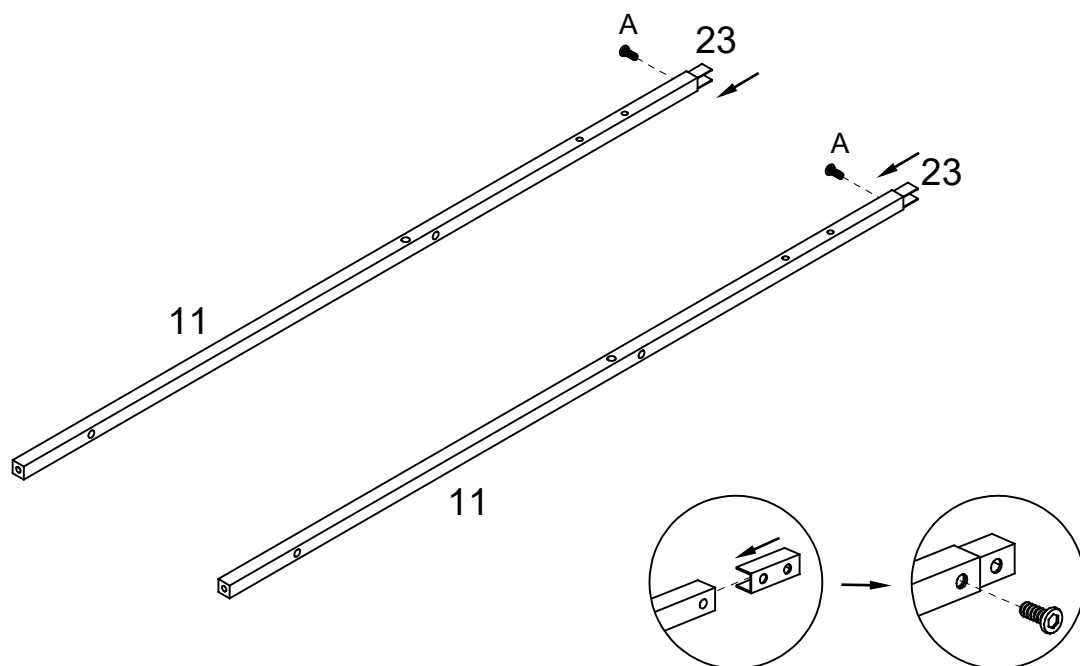

A | M6X12 | X2

Step 8

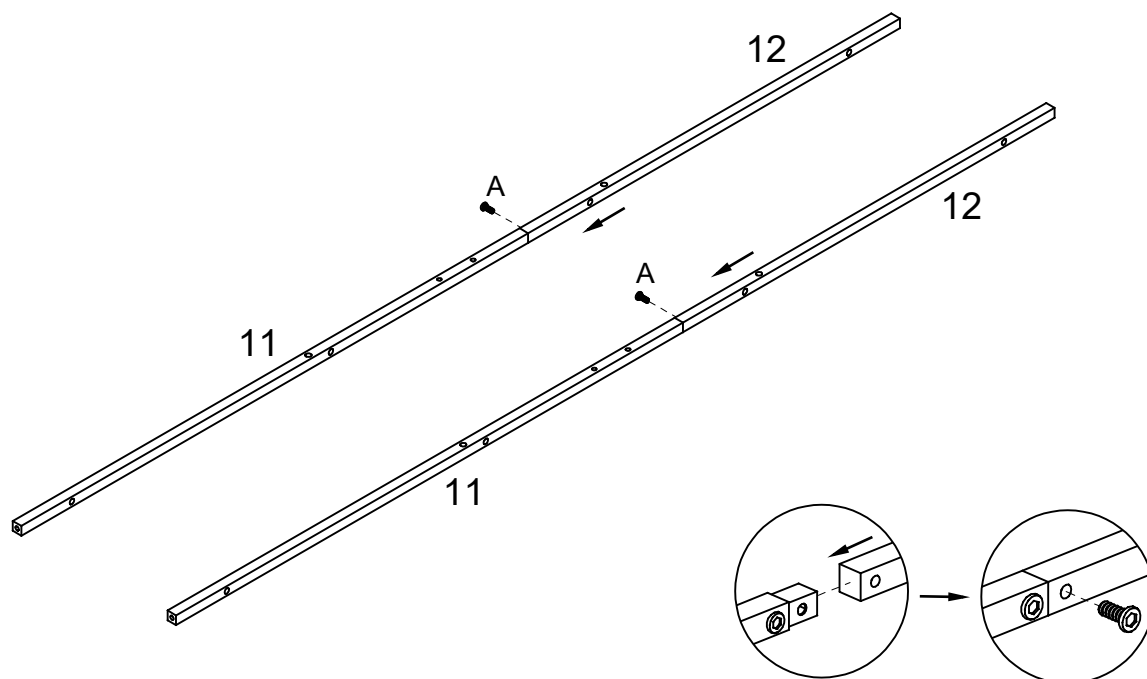

A | M6X12 | X2

Step 9

Screw b locks 80%

Backward

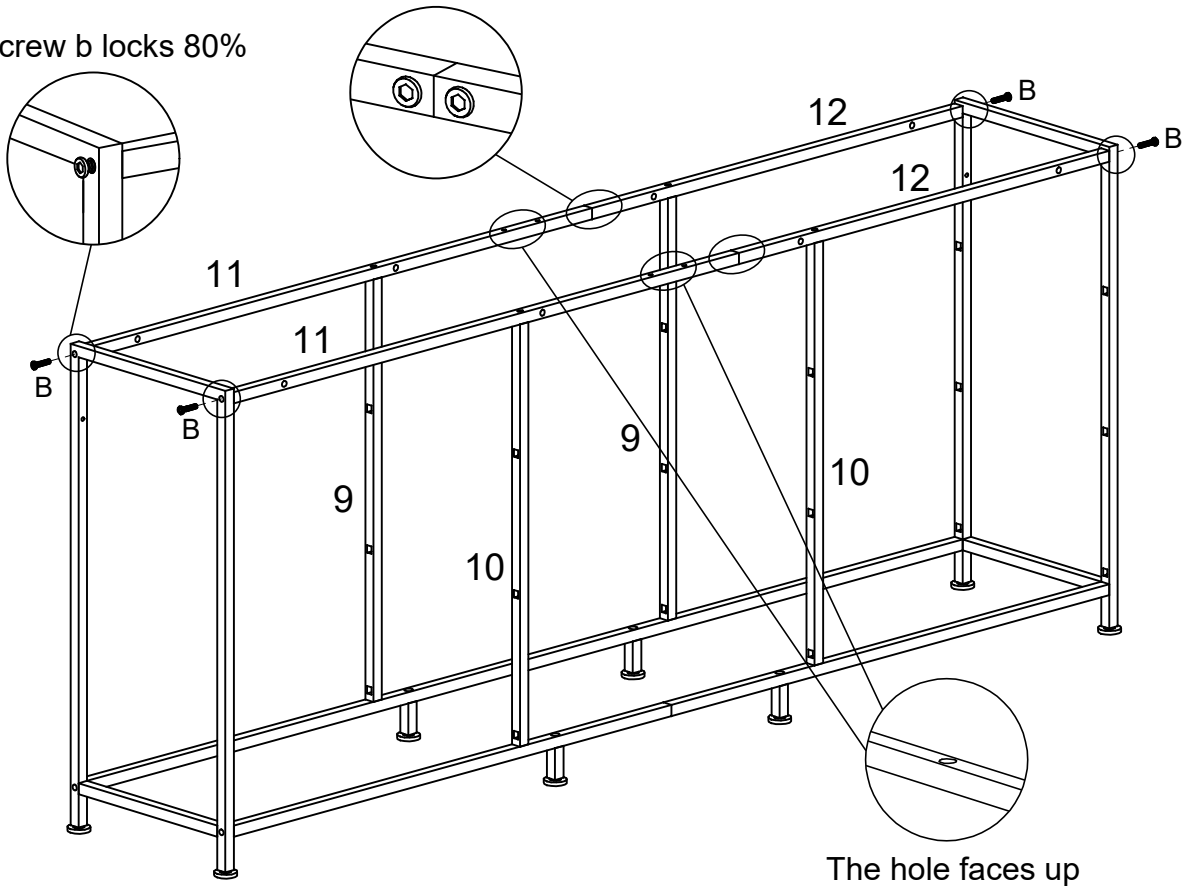

B M6X22 X4

Step 10

Countersunk hole facing down

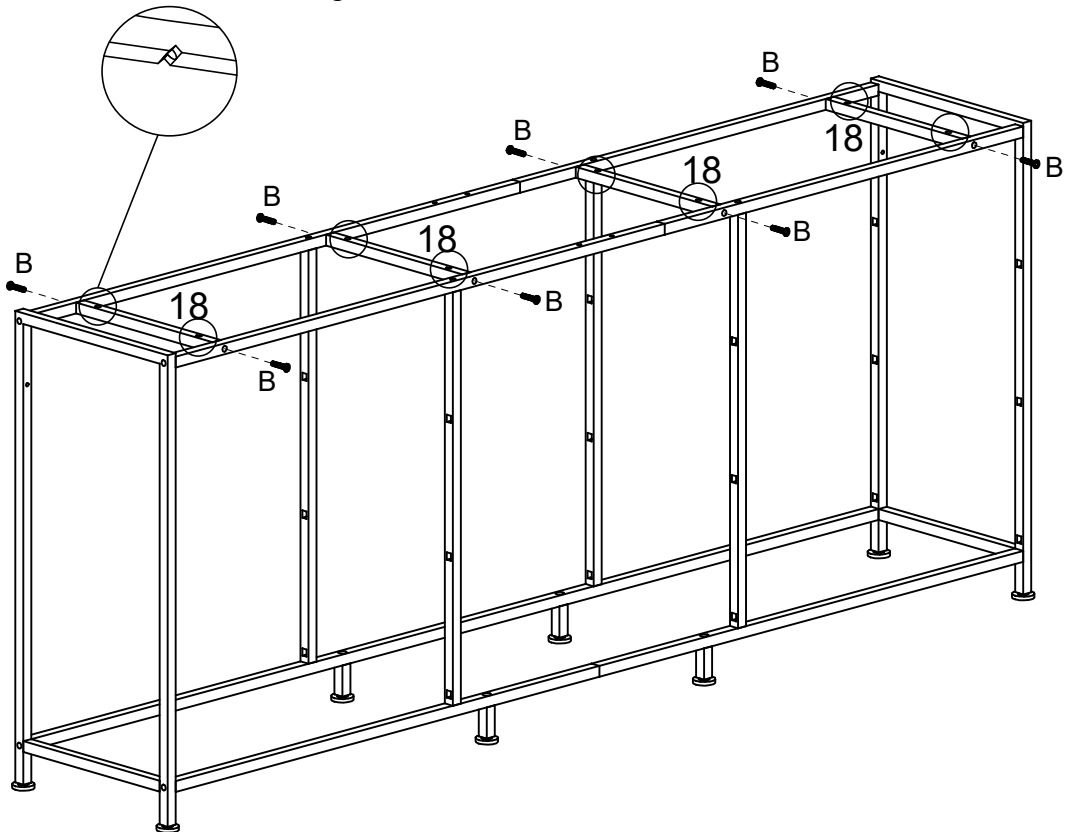

B M6X22 X8

Step 11

Locking screw

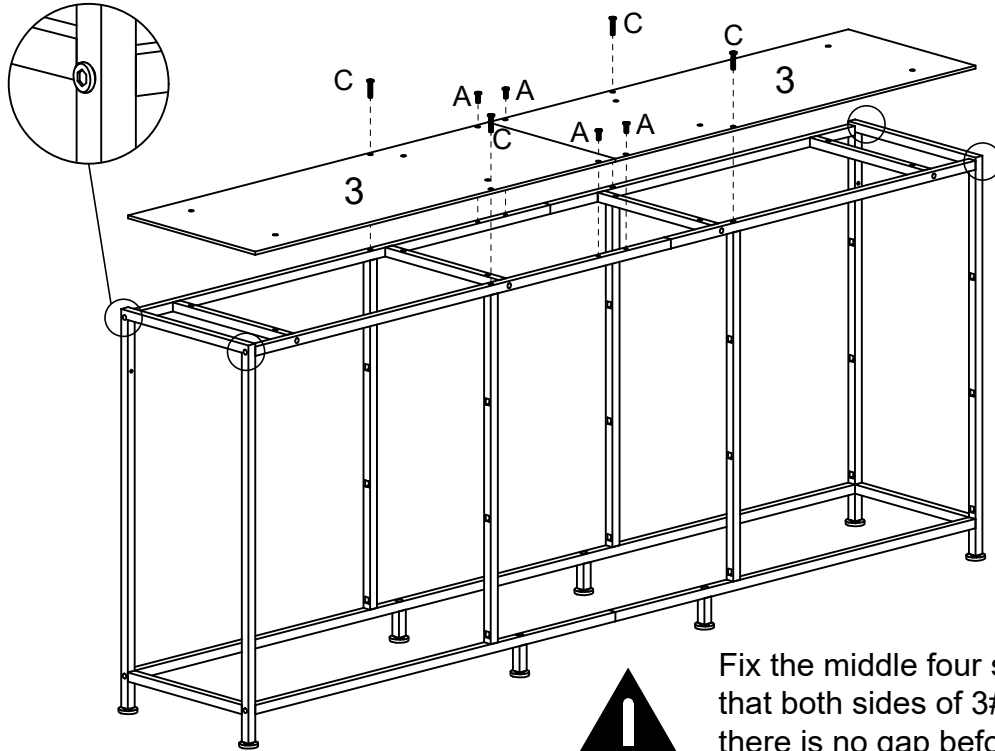

Fix the middle four screws A to ensure that both sides of 3# are flush and there is no gap before locking the screws C on both sides

A	M6X12	X4
C	M6X28	X4

Step 12

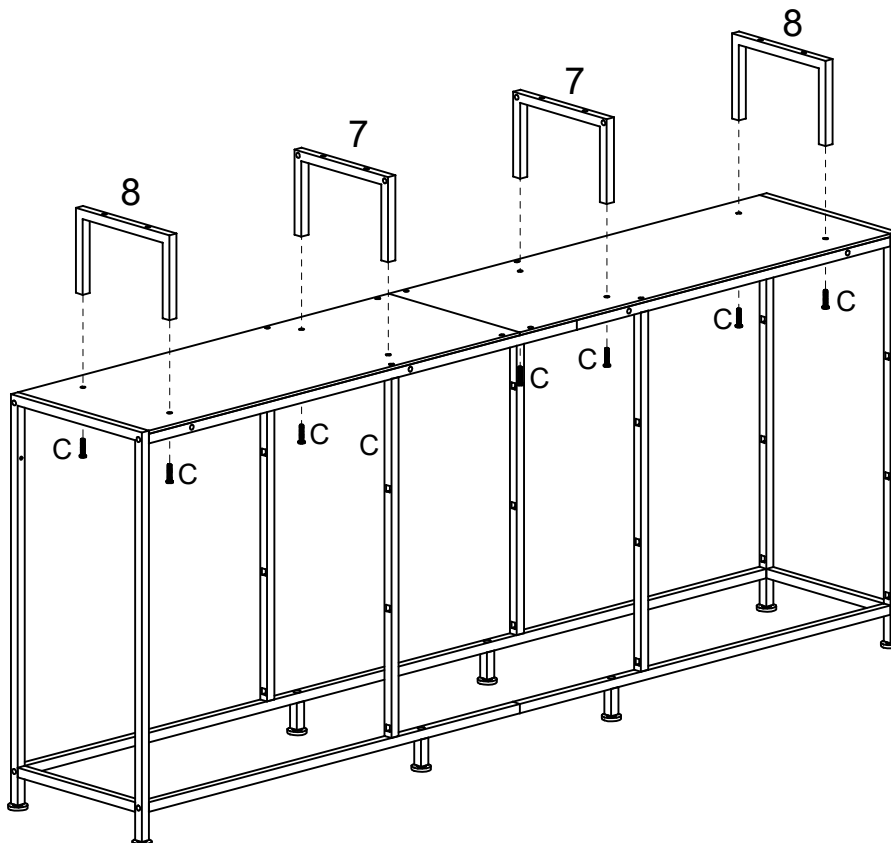

C	M6X28	X8
---	-------	----

Step 13

The hole faces up

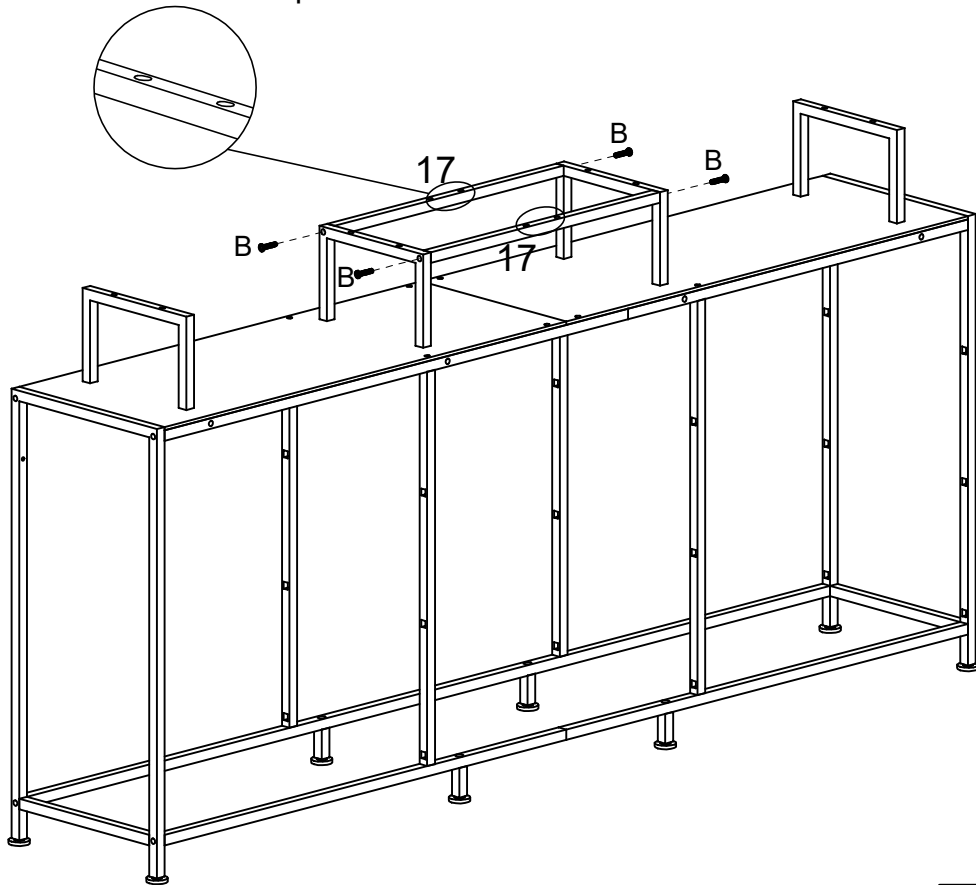

B M6X22 X4

Step 14



Fix the four screws in the middle first to ensure that both sides of 1#2# are flush and there is no gap before locking the screws on both sides

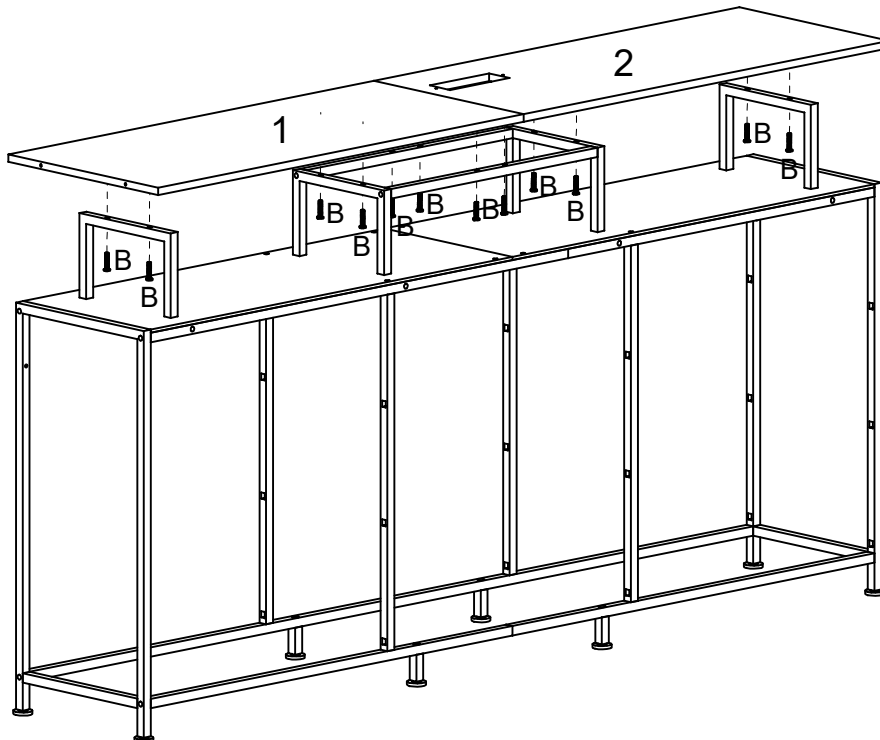

B M6X22 X12

Step 15

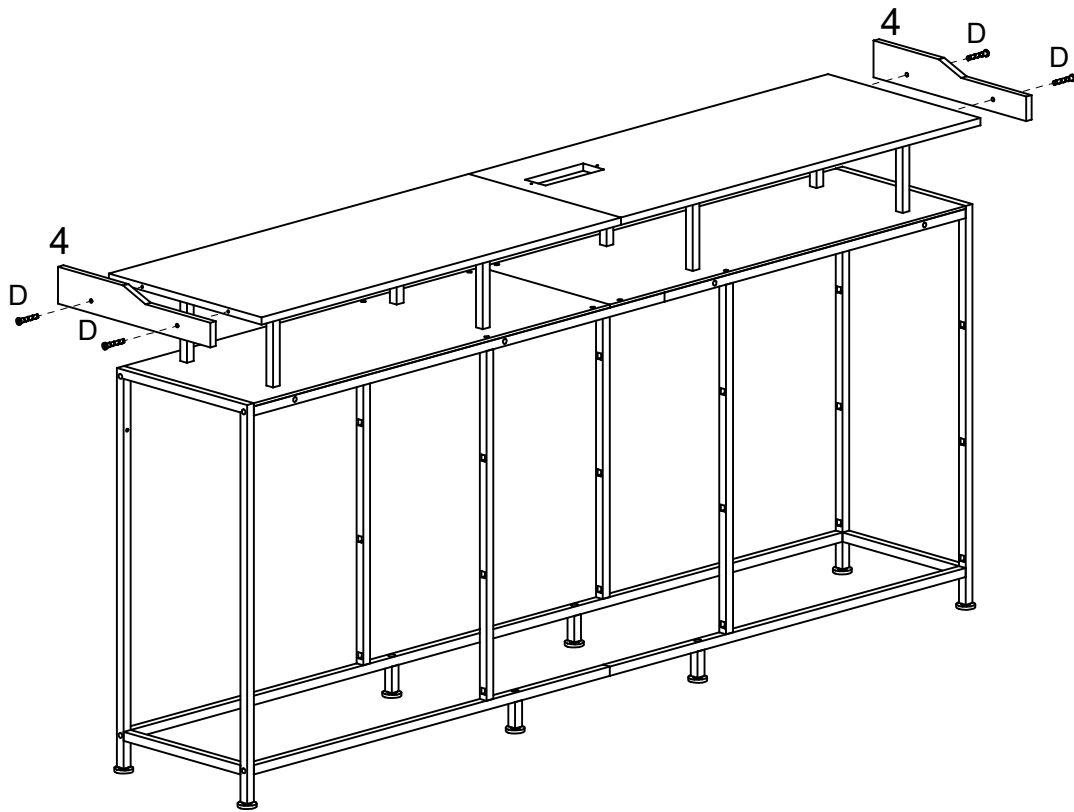

D M5X40 X4

Step 16

Rip the protective paper

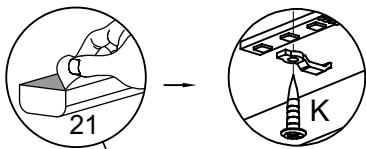

After installing the light strip, fix it on the board with screws K

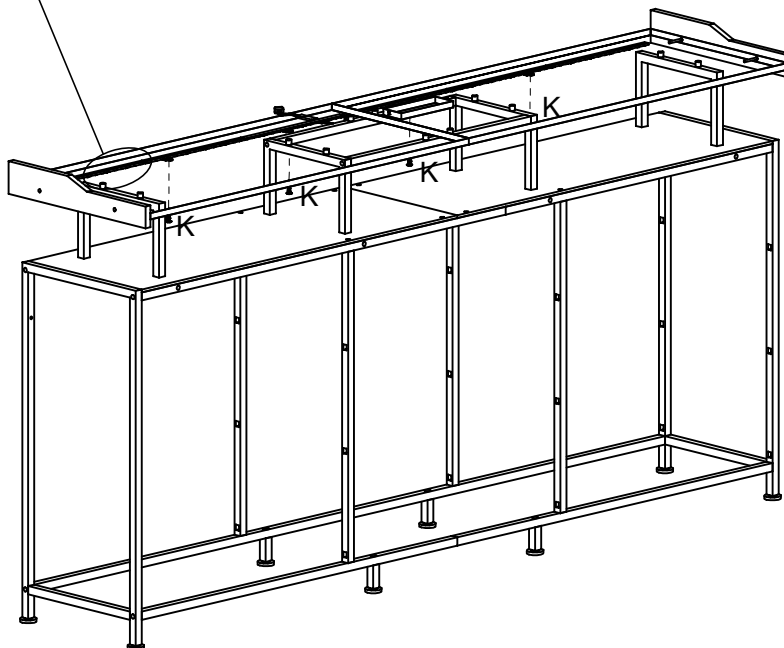
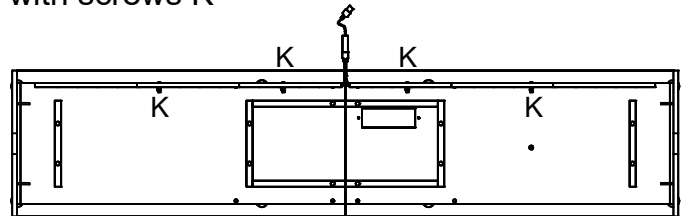

K X4

Step 17

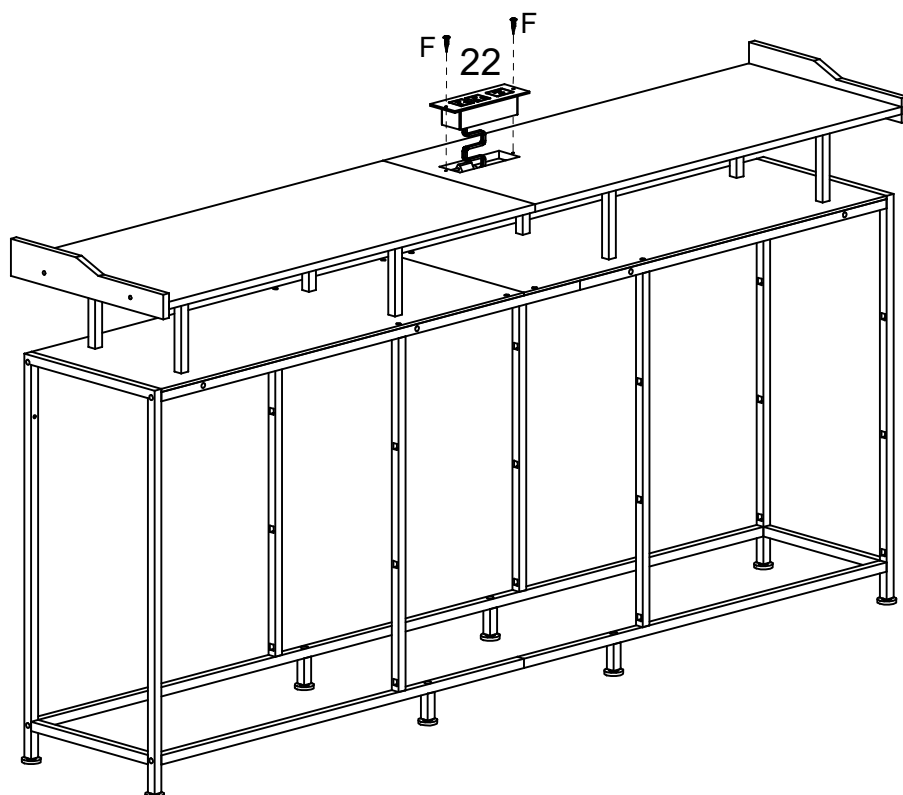

F M4X12 X2

Step 18

back view

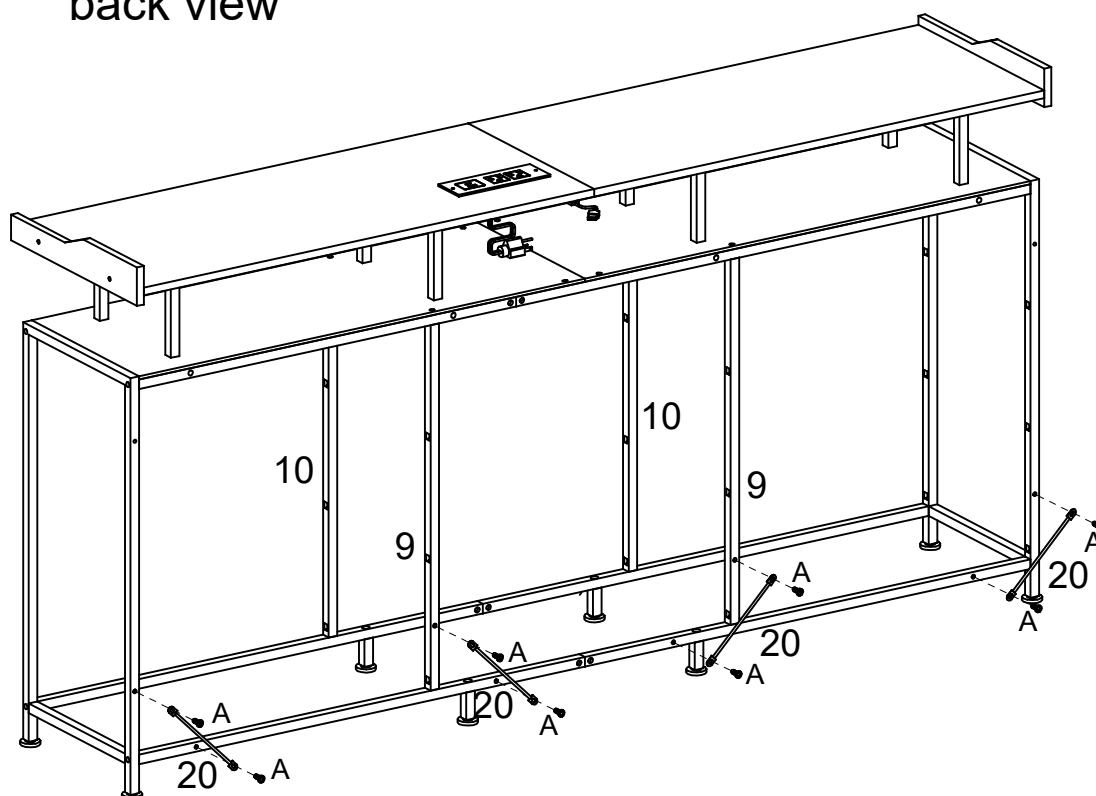

A M6X12 X8

Step 19

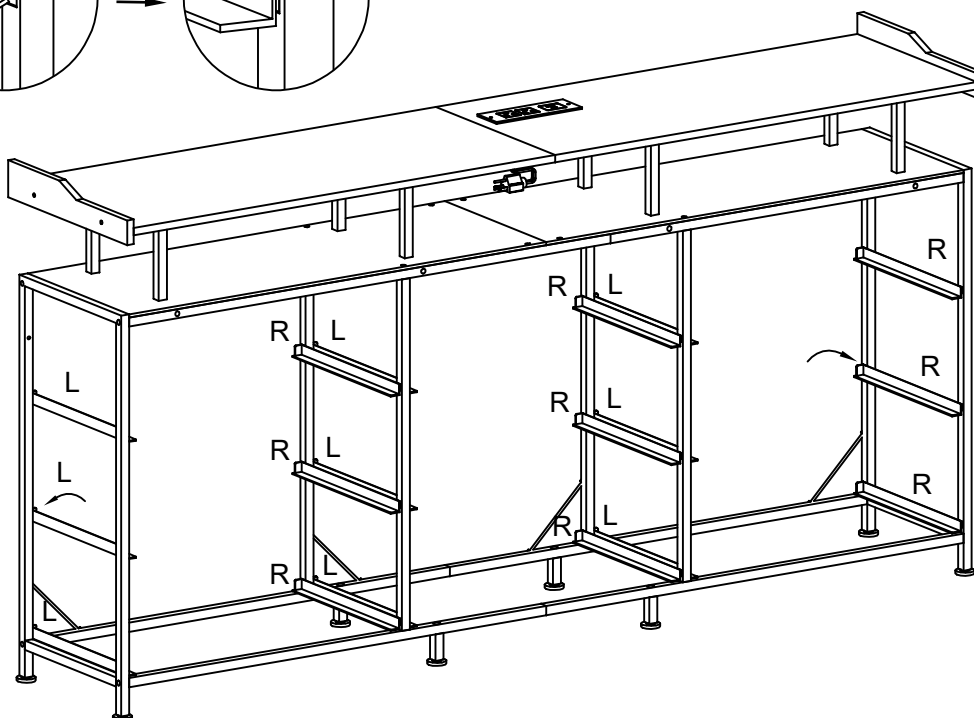
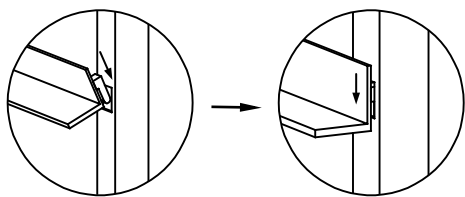

L	X9
R	X9

Step 20

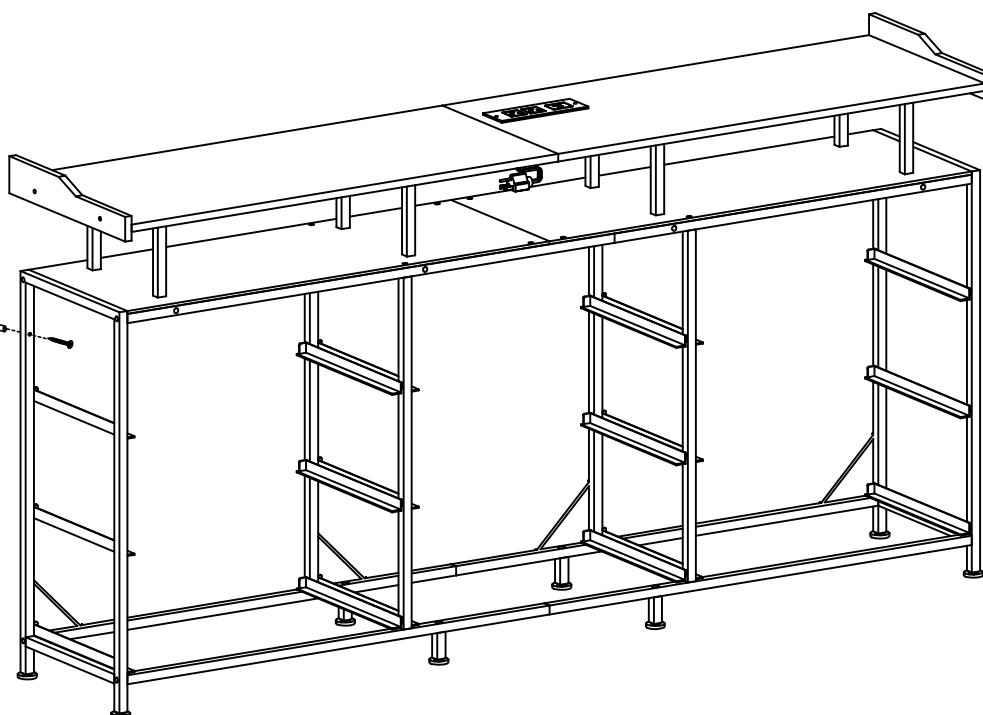
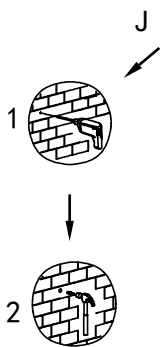

J	X2
---	----

Step 21

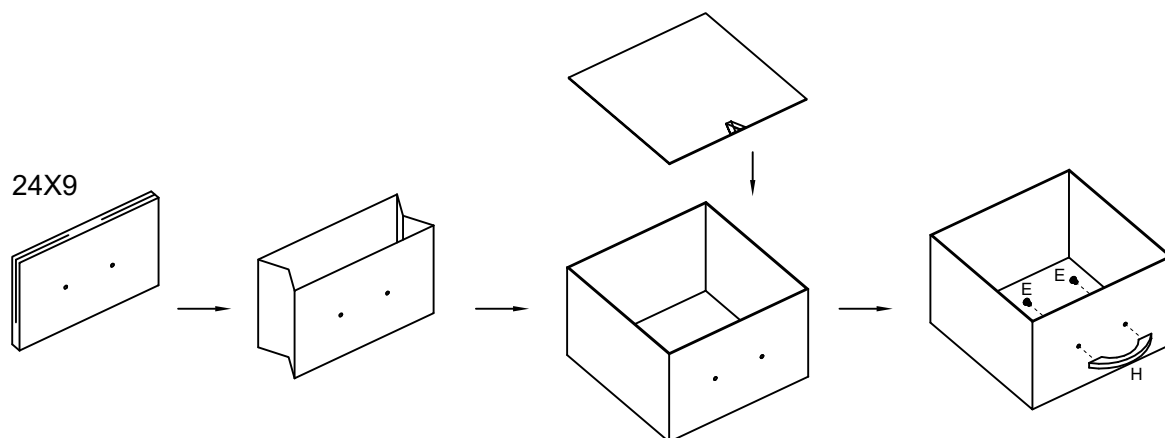

E	M4X10	X18
H		X9

