

Instruction booklet



The type and quantity of components may vary for different style sheds. Assembly of all shed styles is by the same method as detailed.

Before assembling the shed, please check that all parts are present.

Report any shortages or other issues immediately.

No.	Components	Number
1 or 1a	Front panels	2 or 3
2	Rear panels	2
3	Left side panel	1
4	Right side panel	1
5	Felt	1
6	Floor (may be 1 or 2 panels)	1 or 2
7	Roof panel (may be 1 or 2 panels)	1 or 2
8	Door	1 or 2
9	Windows (optional)	Optional
10	Window bead 15mm x 20mm (optional)	Optional
11	Floor bearers tanalised 26mm x 38mm	Variable
12	Barge boards	4
13	Tee Hinges	3 (single door) 6 (double door)
14	Turn button	1 (single door) 2 (double door)
15	Corner cover strips 11mm x 41mm	4
16	Hasp and Staple	1

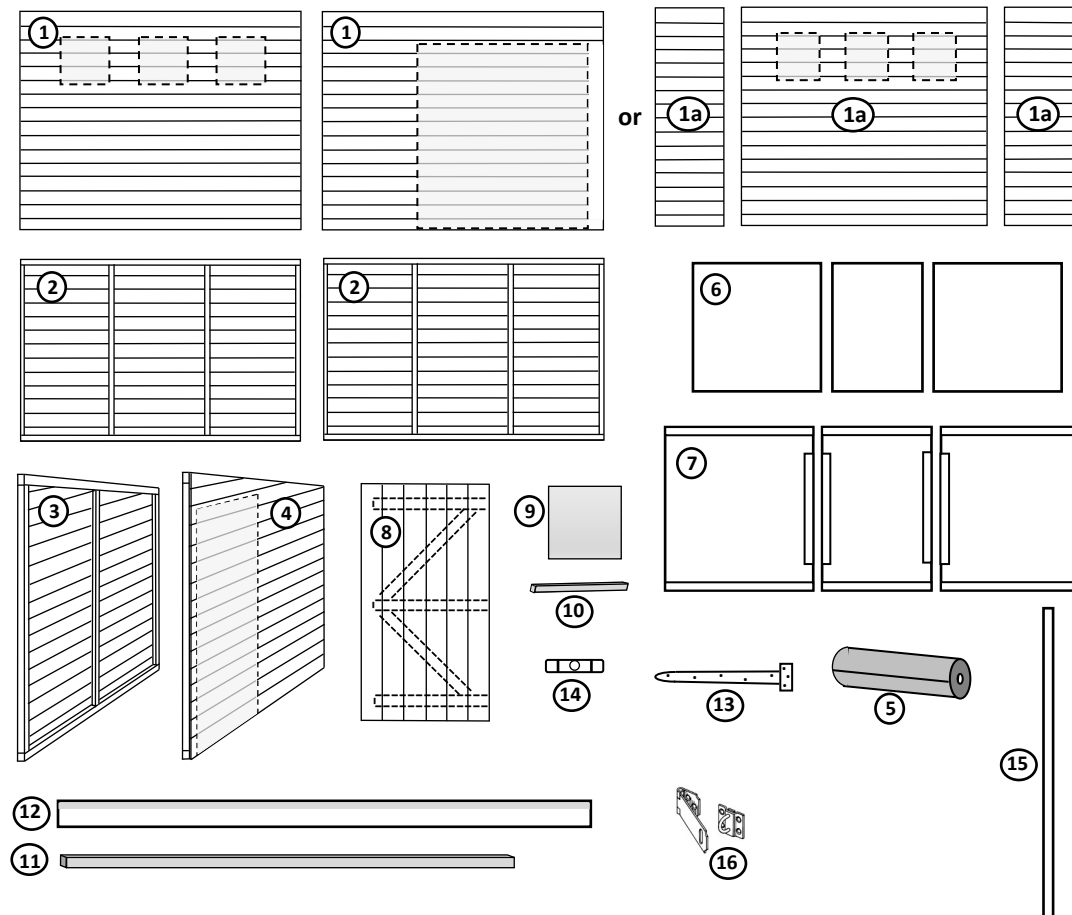

Adequate provision must be made to ensure that the floor boards of the building do not come into direct contact with the ground and air is able circulate underneath. A concrete or paving slab base is acceptable, but the building must not be allowed to sit in pooled water during wet conditions.

Timber Information. Timber is a natural product and can therefore be subject to warping, shrinkage, splitting etc...Periods of excessive dry spells can cause the timber to lose internal moisture resulting in shrinkage on a panel. During periods of excessive wet spells, the timber may experience some swelling. Unfortunately this process cannot be avoided. If you have problems with certain boards shrinking, try to decrease the amount of direct sunlight it gets. During hot spells spray any shrunken boards with a hosepipe, this will replenish the moisture in the timber.

Fixings	
60mm screws	32mm ringshank nails
40mm screws	13mm clout nails
25mm black screws	30mm panel pins (windows options only)

If you have any questions or queries during the assembly of your building please contact us:-

We are constantly improving and updating the quality of our products and as such some components may differ from those shown. We reserve the right to change the specification of our products without prior notice.

1. Floor Section

The floor and floor bearers are supplied separately.

The ROOF is supplied with batons already attached.

Depending on the size of your shed, you will have either 3 or 4 floor boards, which should be fixed together as shown below.

Attach the floor bearers as shown below. Starting at one end, place each floor bearer approx. 30cms apart, ensuring that one bearer is fixed along both outer edges of the floor. Where two boards meet, ensure that they are joined together onto one floor bearer as shown below.

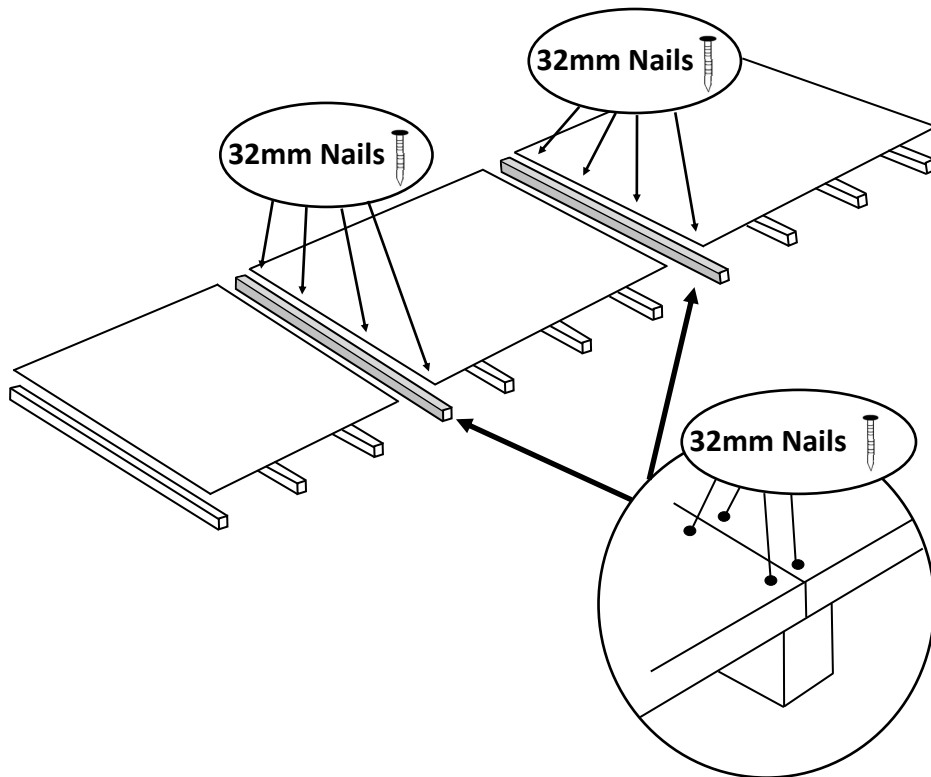

2. Wall Panels

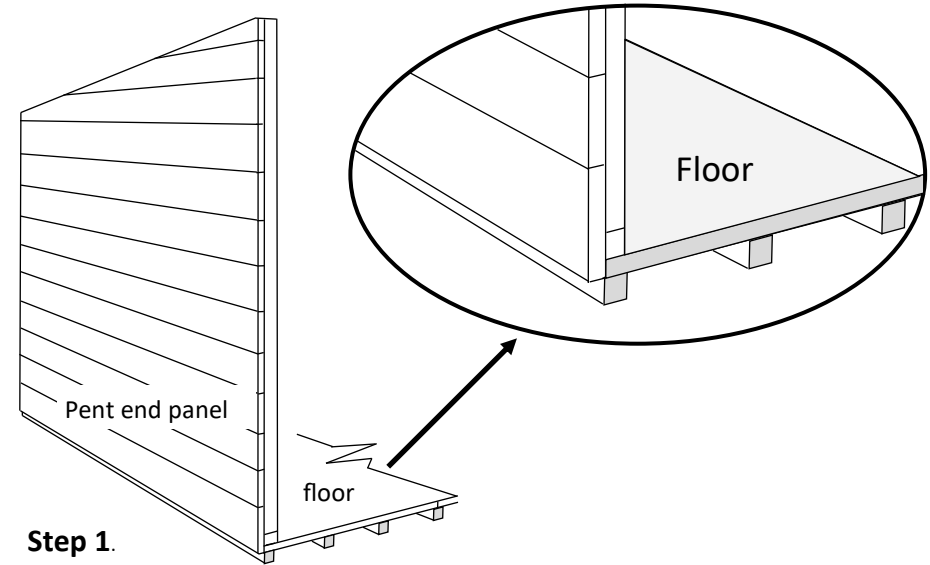

Step 1.

Position the first side panel (one of the panels with the sloping top) so that the edge of the panel is flush with the edge of the floor at both ends and the overhang on the bottom of the panel is butted up to the floor. These panels are the same width as the floor board.

Step 2.

Position the corresponding front or rear panel next to the end panel, to make a corner. The cladding of the front/rear panel should be proud of the end panel to allow fitting of the corner cover strips, as shown below.

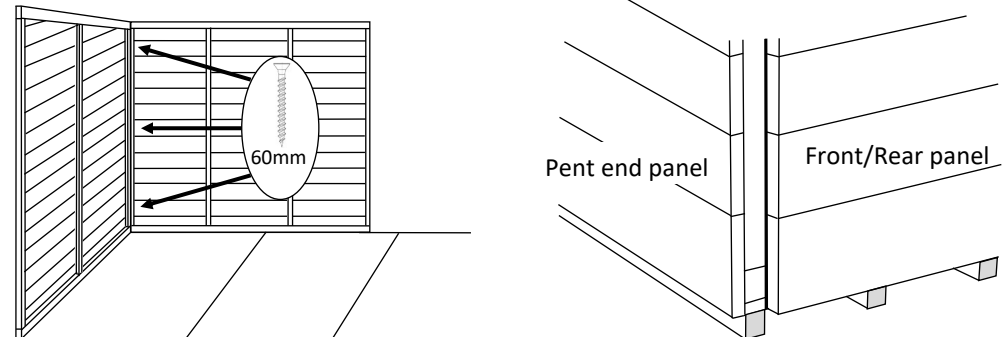

Step 3.

Fix the remaining panels in place using the method shown in step 2.

Do not screw any of the panels to the floor at this point.

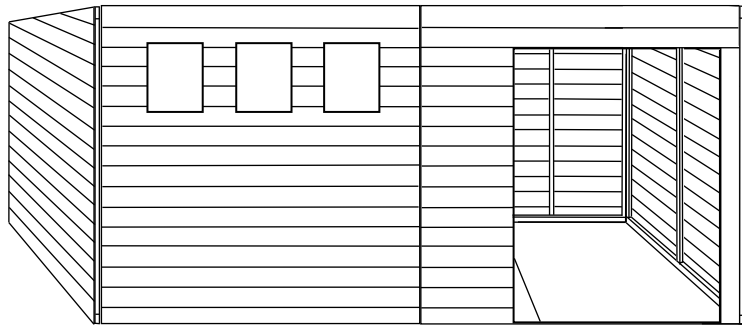
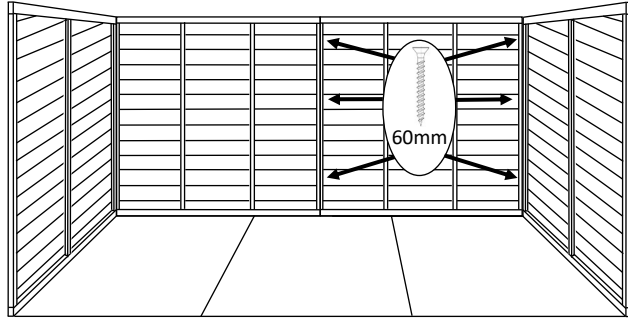
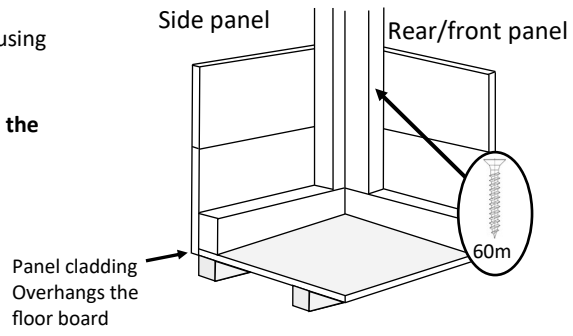

Step 4 .

Once all of the sides are screwed into position, attach the corner cover trim as shown using 32mm nails.

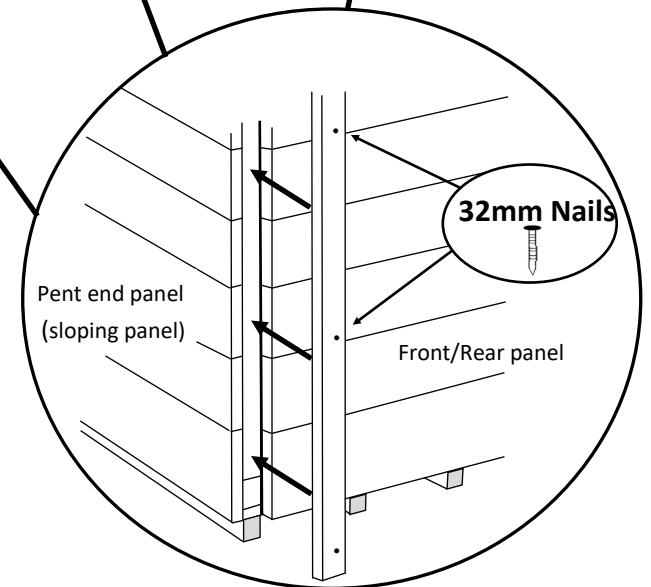
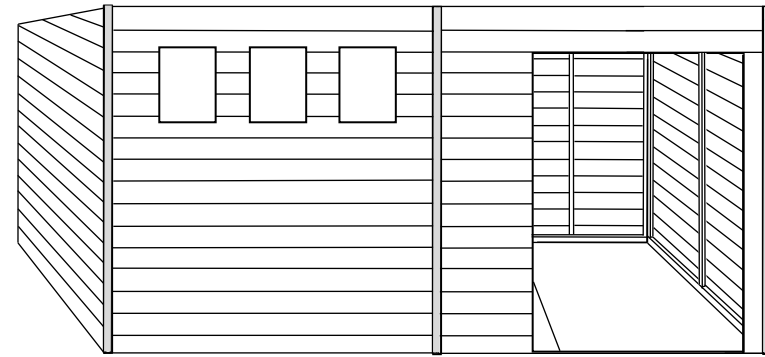

3. Roof

Step 1.

Position the roof boards onto the top of the shed. The longer batons on the roof boards should run through the middle of the shed and be screwed together as shown.

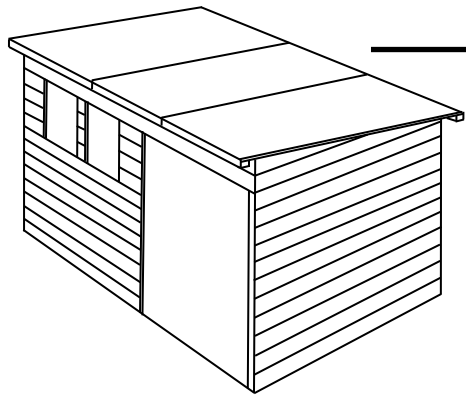
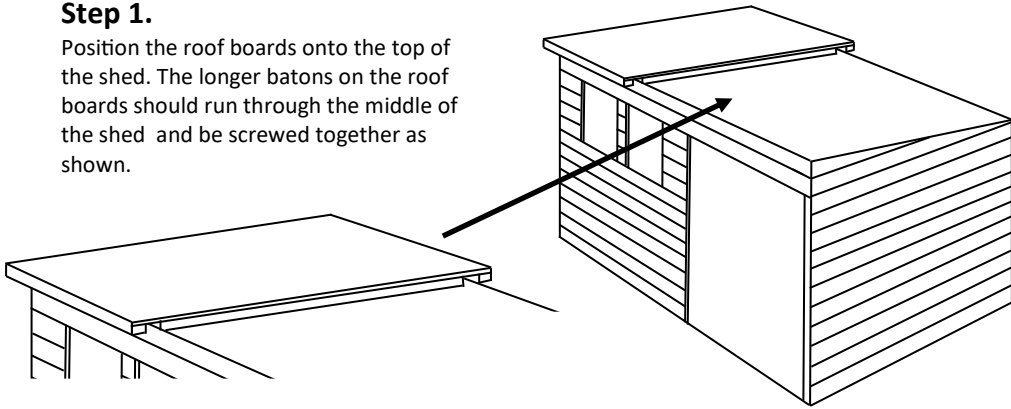

Underside of roof

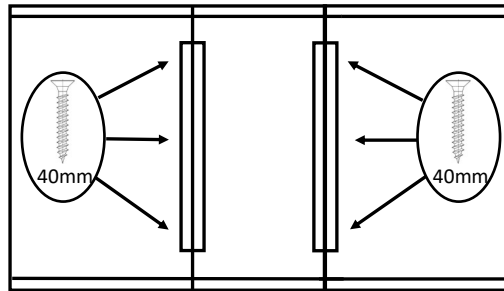

Step 2.

Fix the roof boards to the building using 40mm screws directly through the roof sheet into the panel framing.

Once the roof is squared up and screwed down, you can then screw all of the side panels to the floor of the shed using 60mm screws.

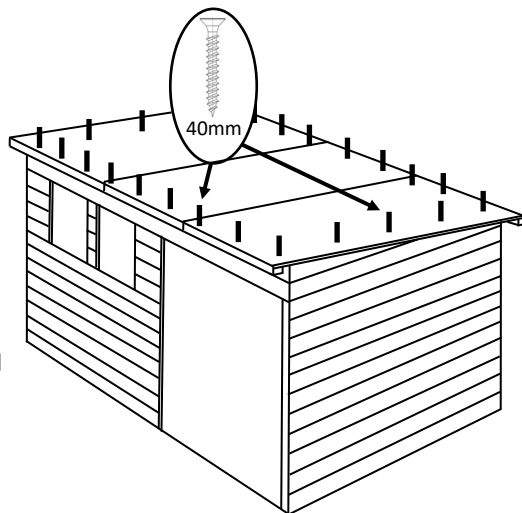

4. Felt

Step 1.

Starting with the lower part of the roof using 13mm nails, attach the felt to the roof ensuring there is a 40mm overhang around the sides. See fig a.

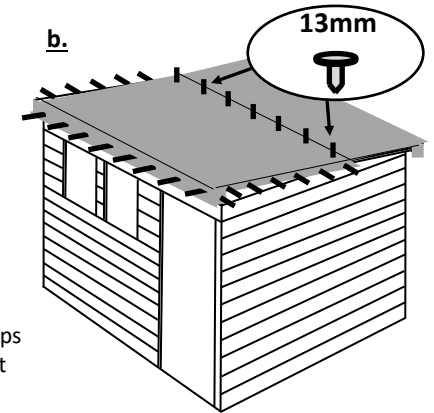
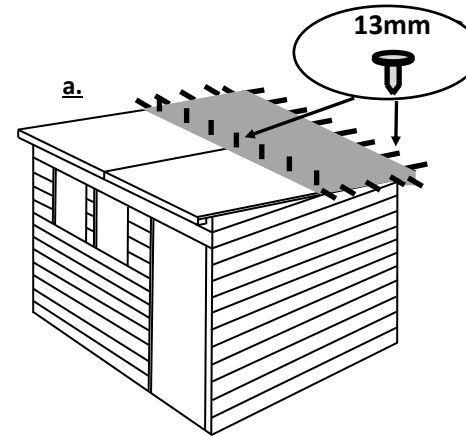

Step 2.

Lay the remaining pieces of felt onto the roof as shown in fig b. ensuring that each piece overlaps the the previous piece by at least 10cm.

Step 3.

Fix the fascias using 32mm nails. Ensure to trap the felt between the fascia and the roof board.

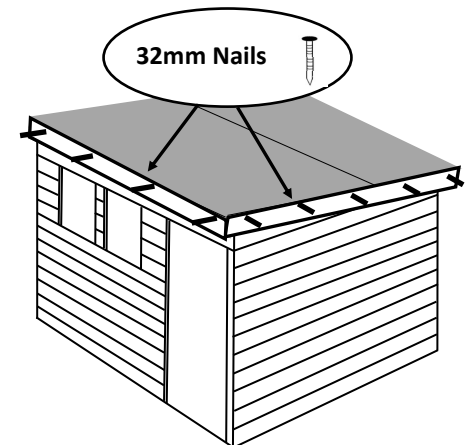

5. Doors

Lie the door on a flat surface with the cladding facing upwards. Take one T hinge and position on the door as shown below, making sure that the T hinge is directly above the brace on the underside of the door. Fix the T hinge into place with the 25mm black screws. Repeat for the remaining T hinges. With the T hinges secured, position the door squarely in the door frame. Fix the top hinge first with 1 screw and the bottom hinge second with the 25mm black screws. Make sure that the door can open and close freely and then fix the remaining screws into the hinges

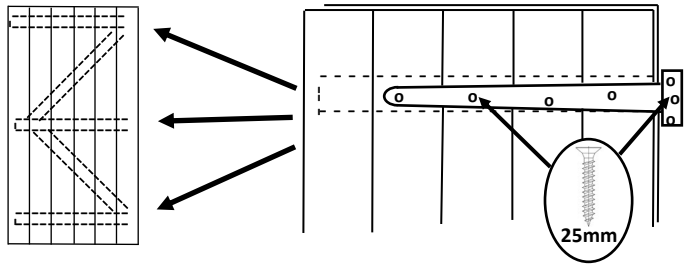

6. Hasp and Staple

Attach the hasp and staple to the outside of the door and door frame, using the black 25mm screws, as shown below.

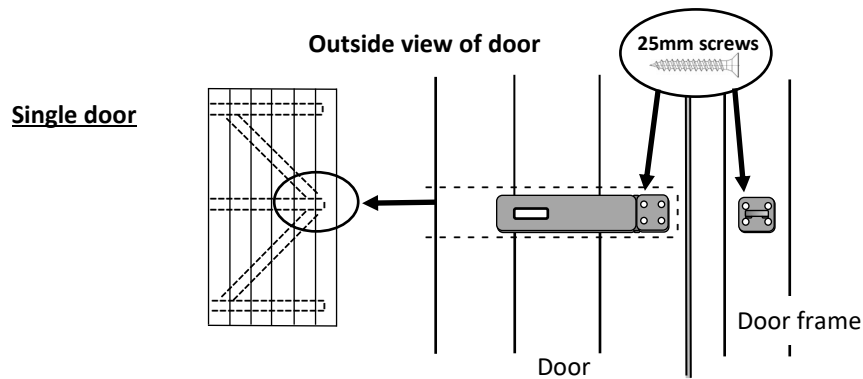

Double door

If your shed has a double door, see opposite. Using a hand saw, you will need to cut out a small section of the weather strip on the door over the middle brace, to allow fitting of the hasp and staple.

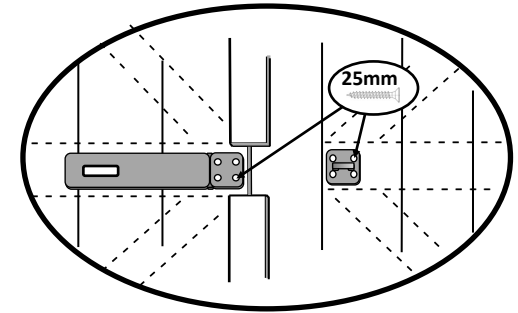

7. Windows (optional)

To fit the windows it is recommended that a waterproof sealant is applied around the edge of the glazing before fitting. From the inside of the building fit the styrene window into the frame and secure in place with the 4 strips of window bead. Fix the window bead to the window frame with 30mm panel pins.

