

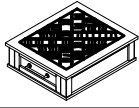

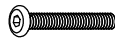

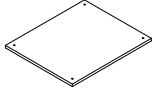

# ASSEMBLY INSTRUCTION

## DESCRIPTION: RECTANGULAR END TABLE

**Thank you for purchasing this quality product. Be sure to check all packing material carefully for small parts, which may have come loose inside the carton during shipment. Identify and count all parts and compare with the parts list below.**

PARTS LIST				HARDWARE LIST			
NO	DRAWING	DESCRIPTION	QTY	NO	DRAWING	DESCRIPTION	QTY
1	Table Top		1	A		Bolt Ø1/4"x70mm	4
2	Base		1	B		Bolt Ø1/4"x20mm	16
3	Leg		4	C		Spring Washer Ø1/4"	20
4	Bun Foot		4	D		Flat Washer Ø1/4"xØ13mm	20
				E		Allen Key 4mm	1

### STEP 1

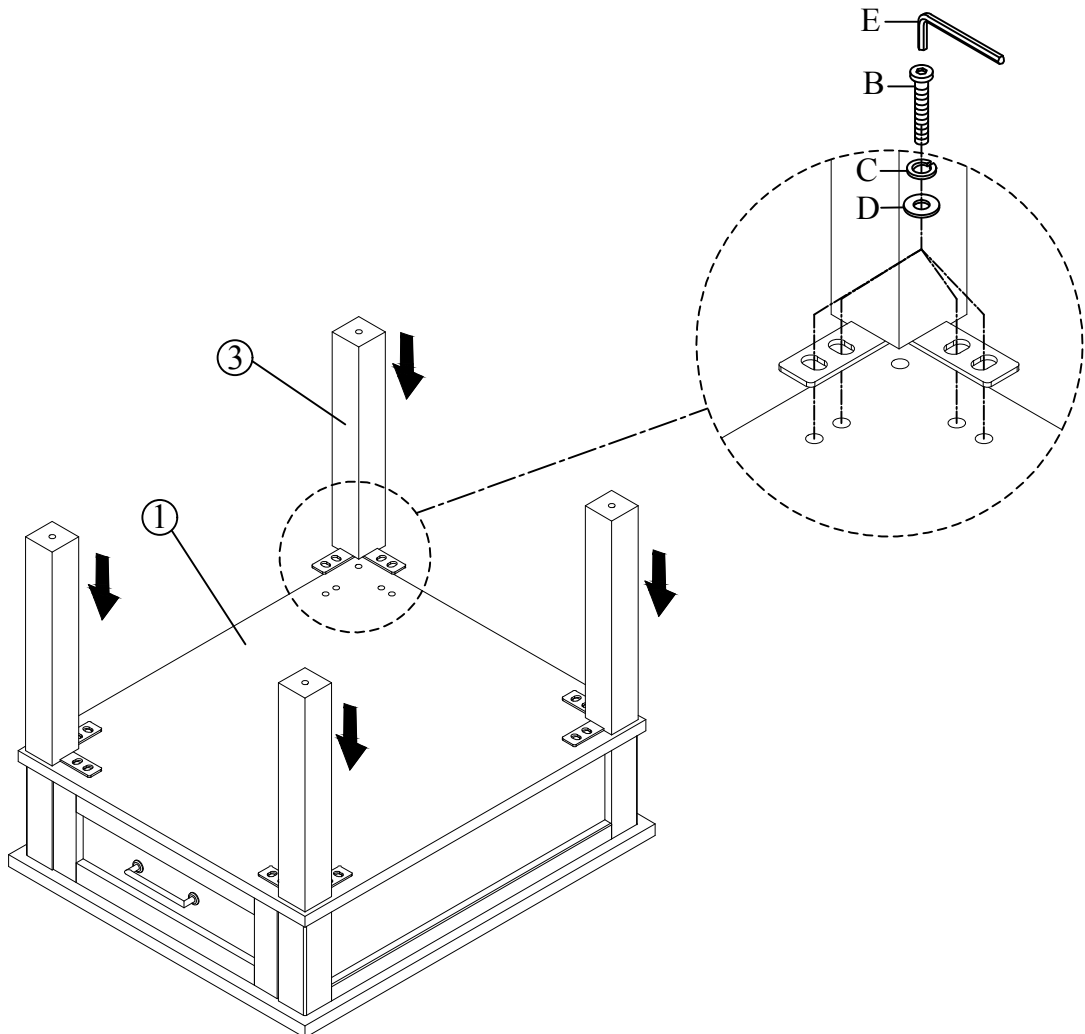

## ASSEMBLY INSTRUCTION

### DESCRIPTION: RECTANGULAR END TABLE

Thank you for purchasing this quality product. Be sure to check all packing material carefully for small parts, which may have come loose inside the carton during shipment. Identify and count all parts and compare with the parts list below.

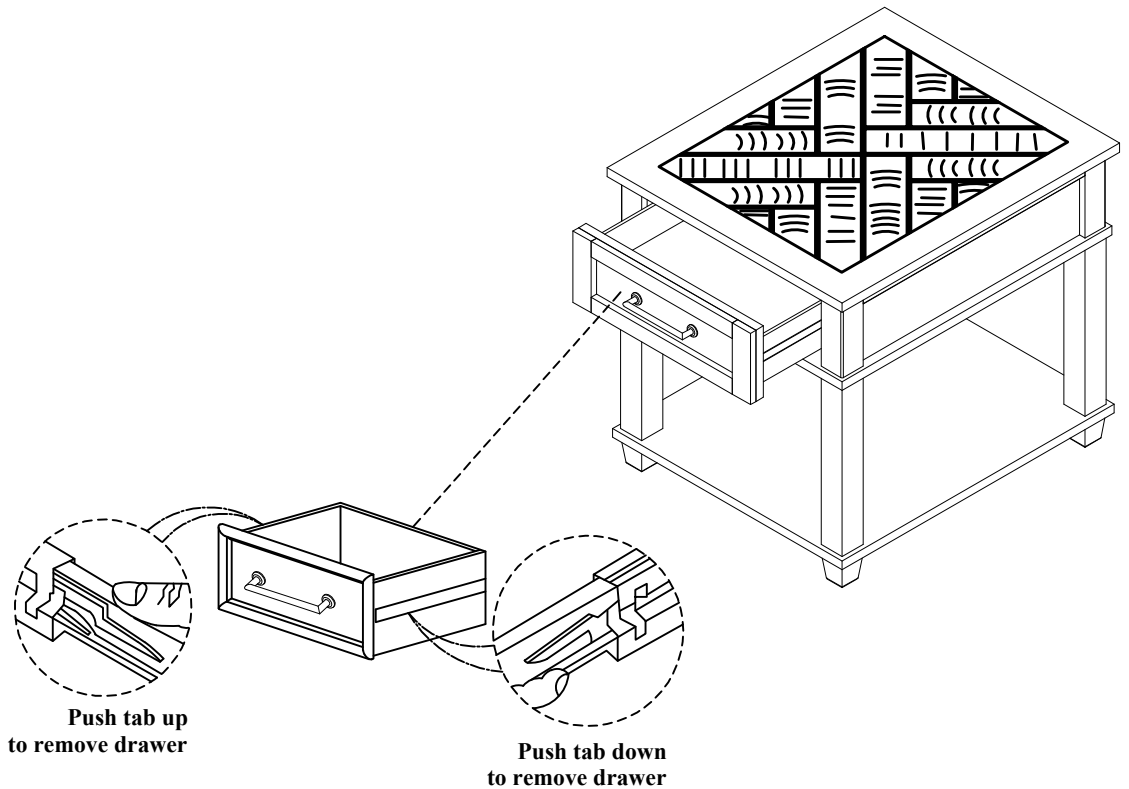
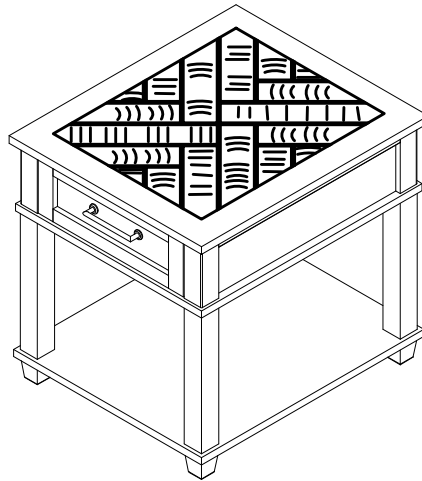

**To remove drawer,  
simultaneously pull tab  
up on one side and  
push down on the other  
and remove drawer**

# ASSEMBLY INSTRUCTION

## DESCRIPTION: RECTANGULAR END TABLE

Thank you for purchasing this quality product. Be sure to check all packing material carefully for small parts, which may have come loose inside the carton during shipment. Identify and count all parts and compare with the parts list below.

### STEP 2

