

ASSEMBLY INSTRUCTION

INSTRUCTIONS DE MONTAGE

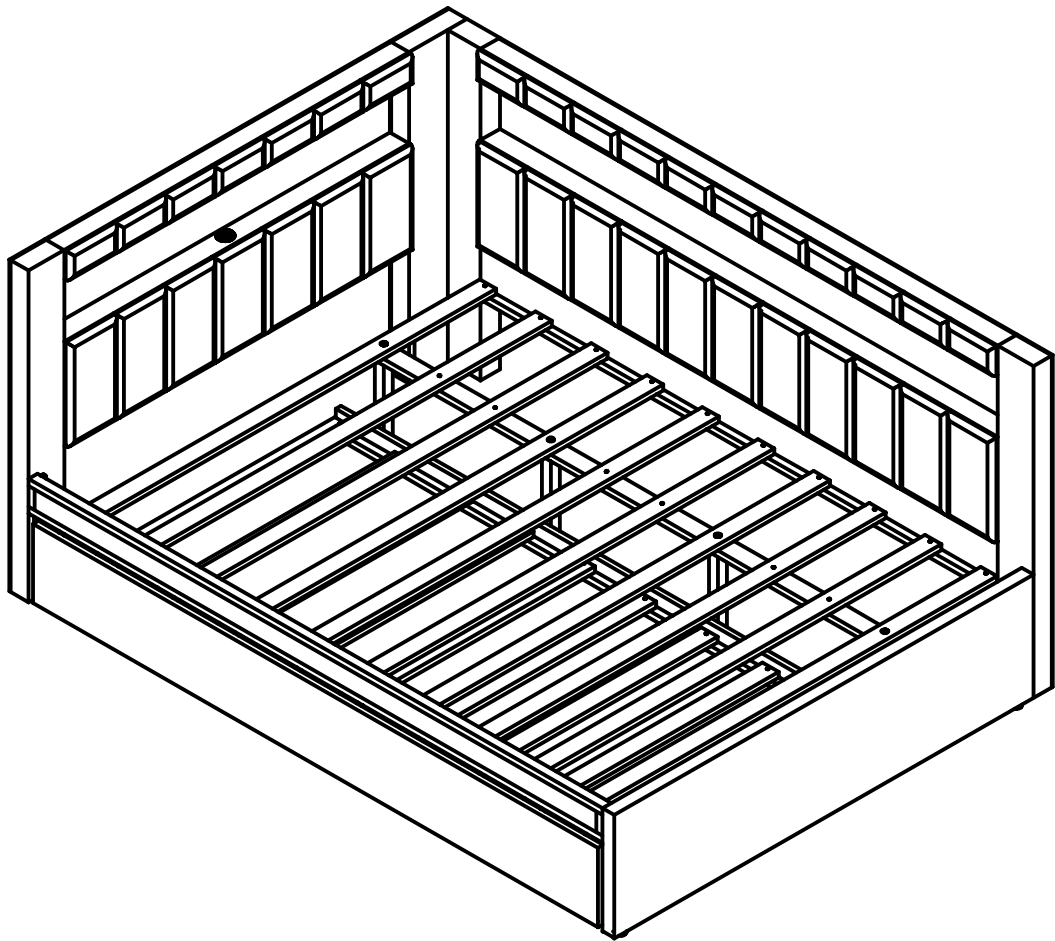

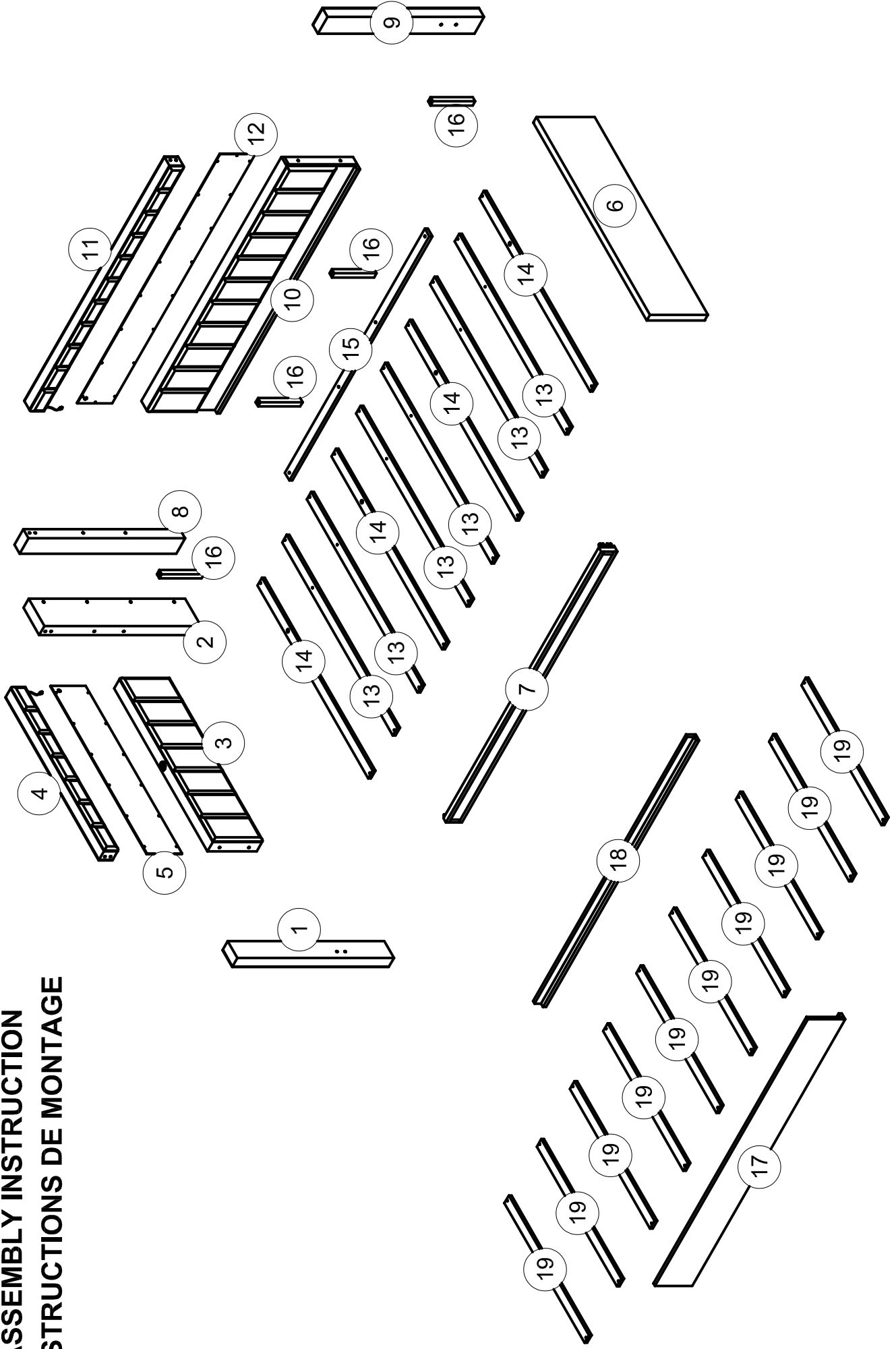



**ASSEMBLY INSTRUCTION
INSTRUCTIONS DE MONTAGE**



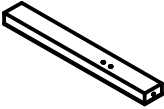
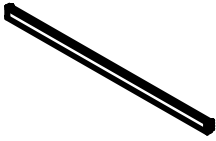
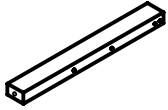
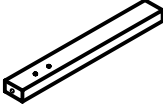
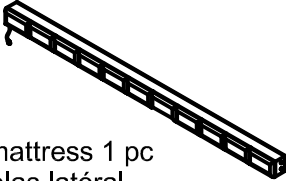
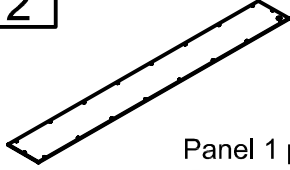
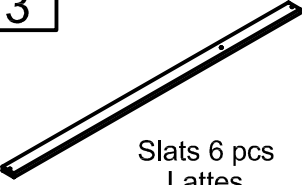

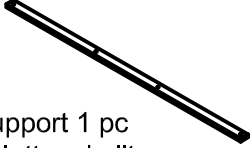
Part List

Liste des pièces

<p>1</p>  <p>Headboard Leg 1 pc Pied de tête de lit</p>	<p>7</p>  <p>Side Rails 1 pc Rails latéraux</p>	<p>8</p>  <p>Side bed leg 1 pc Pied de lit latéral</p>
<p>9</p>  <p>Side bed leg 1 pc Pied de lit latéral</p>	<p>11</p>  <p>Side mattress 1 pc Matelas latéral</p>	<p>12</p>  <p>Panel 1 pc Panneau</p>
<p>13</p>  <p>Slats 6 pcs Lattes</p>	<p>14</p>  <p>Slats 4 pcs Lattes</p>	<p>15</p>  <p>Bed slat support 1 pc Support de lattes de lit</p>
<p>17</p>  <p>Trundle Side Rail 1 pc Rail latéral gigogne</p>	<p>18</p>  <p>Trundle Side Rail 1 pc Rail latéral gigogne</p>	



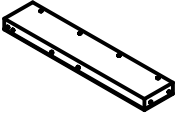
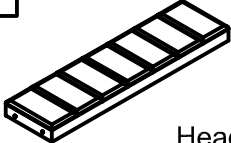
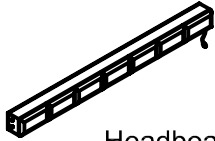
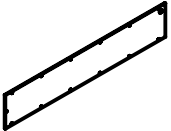
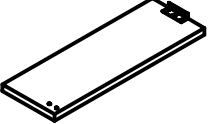
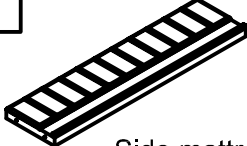

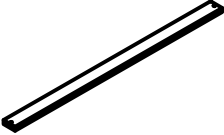









Part List

Liste des pièces

<p>2</p>  <p>Headboard Leg 1 pc Pied de tête de lit</p>	<p>3</p>  <p>Headboard 1 pc Tête de lit</p>	<p>4</p>  <p>Headboard 1 pc Tête de lit</p>
<p>5</p>  <p>Panel 1 pc Panneau</p>	<p>6</p>  <p>Footboard 1 pc Marchepied</p>	<p>10</p>  <p>Side mattress 1 pc Matelas latéral</p>
<p>16</p>  <p>Extra Legs 4 pcs Pieds supplémentaires</p>	<p>19</p>  <p>Slats 10 pcs Lattes</p>	

Hardware List

Liste du matériel

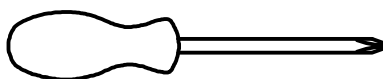

<p>A</p>  <p>1/4" x 30mm Hex-Head bolts 7 pcs Boulons à tête hexagonale 1/4" x 30 mm</p>	<p>B</p>  <p>Plastic Feet(Ø32x16) 7 pcs Pieds en plastique (Ø32x16)</p>	<p>C</p>  <p>Allen Key 1 pc Clé Allen</p>
<p>D</p>  <p>Ø8 x 30 mm Wood dowel 8 pcs Ø8 x 30 mm Cheville en bois</p>	<p>E</p>  <p>1/4" x 50 mm Hex-Head bolts 8 pcs Boulons à tête hexagonale 1/4" x 50 mm</p>	<p>F</p>  <p>Steel Bracket 4 pcs Support en acier</p>
<p>G</p>  <p>M4 x 20 mm Wood Screws 16 pcs Vis à bois M4 x 20 mm</p>	<p>H</p>  <p>1/4" x 40 mm Hex-Head bolts 14 pcs Boulons à tête hexagonale 1/4" x 40 mm</p>	<p>K</p>  <p>Led extension cord 1 pc Rallonge led</p>
<p>L</p>  <p>M4 x 15 mm Wood Screws 50 pcs Vis à bois M4 x 15 mm</p>	<p>M</p>  <p>M4 x 30 mm Wood Screws 46 pcs Vis à bois M4 x 30 mm</p>	<p>N</p>  <p>Wheels 4 pcs Roues</p>
<p>O</p>  <p>Steel Bracket 3 pcs Support en acier</p>	<p>P</p>   <p>A B Fixed brace 2 set Attelle fixe 2 set</p>	



Assembly Tools Required (Not Included)
Outils d'assemblage requis (non inclus)

STEP 1: Following below illustration:

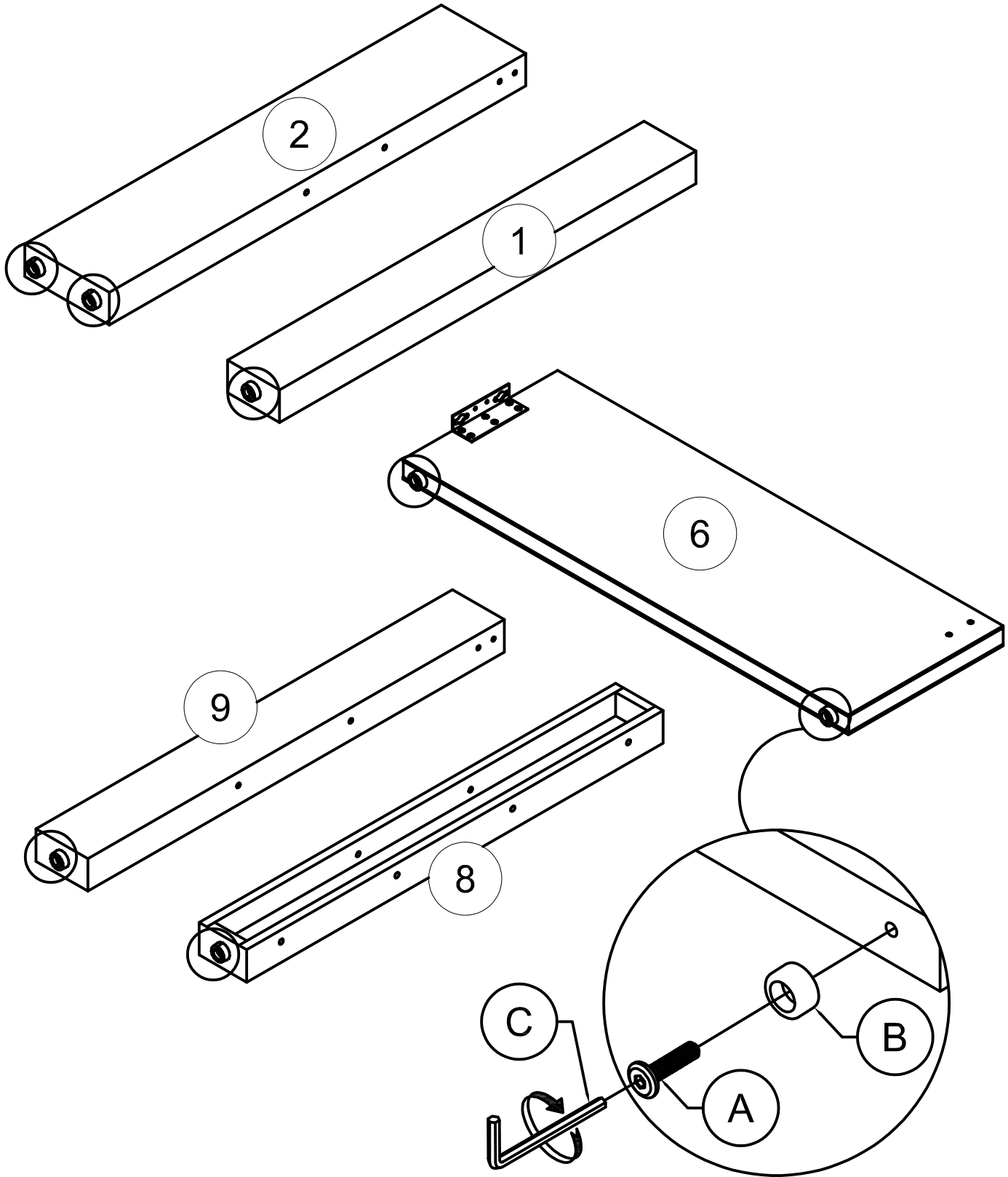

ÉTAPE 1: Suivant l'illustration ci-dessous :

B	A
	
7pcs	7pcs



STEP 2: Following below illustration:

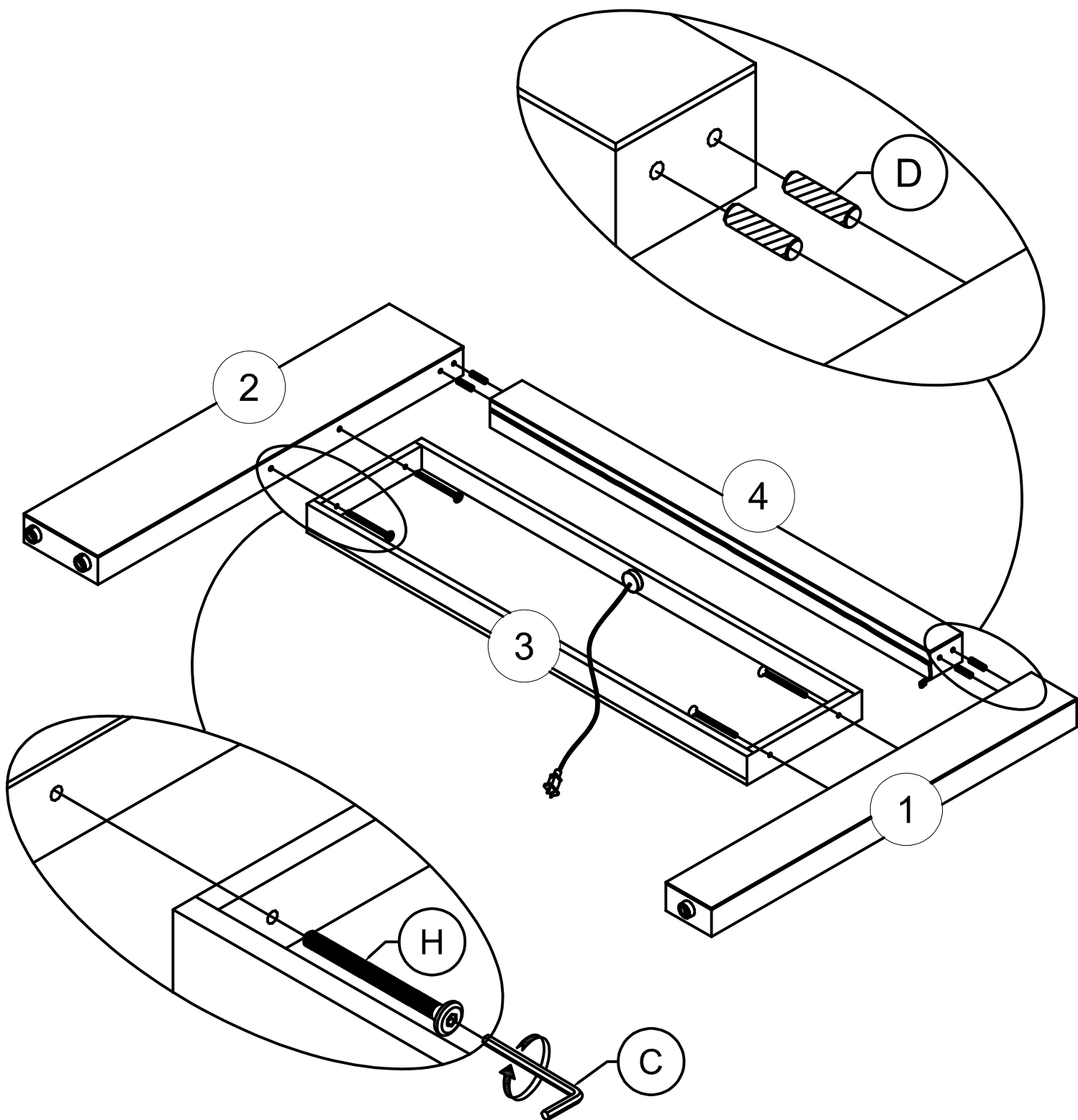

ÉTAPE 2: Suivant l'illustration ci-dessous :

H	D
	
4pcs	4pcs



STEP 3: Following below illustration:

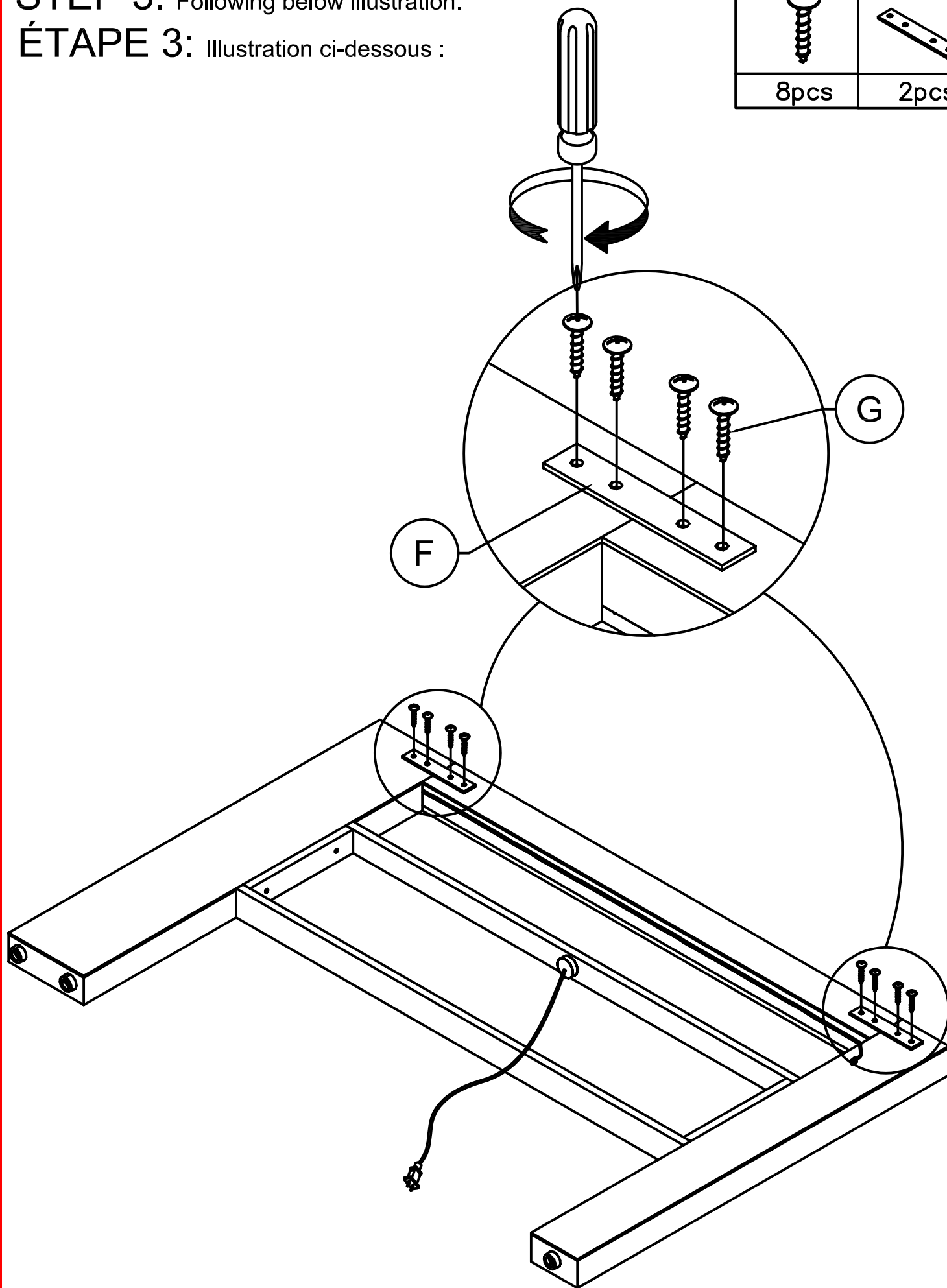

ÉTAPE 3: Illustration ci-dessous :

G		F	
8pcs		2pcs	



STEP 4: Following below illustration:

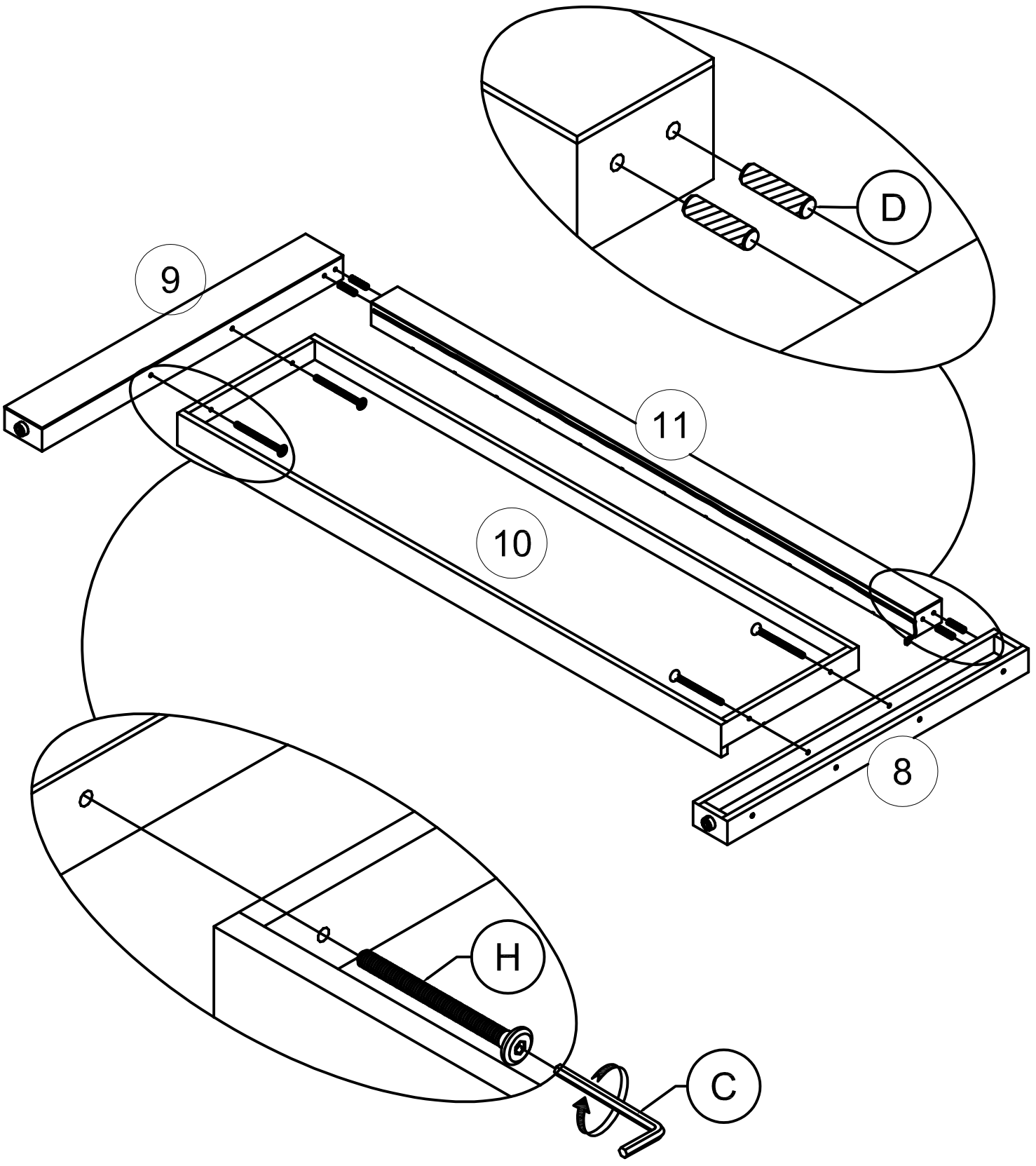

ÉTAPE 4: Illustration ci-dessous :

H	D
	
4pcs	4pcs



STEP 5: Following below illustration:

ÉTAPE 5: Illustration ci-dessous :

G		F	
8pcs		2pcs	

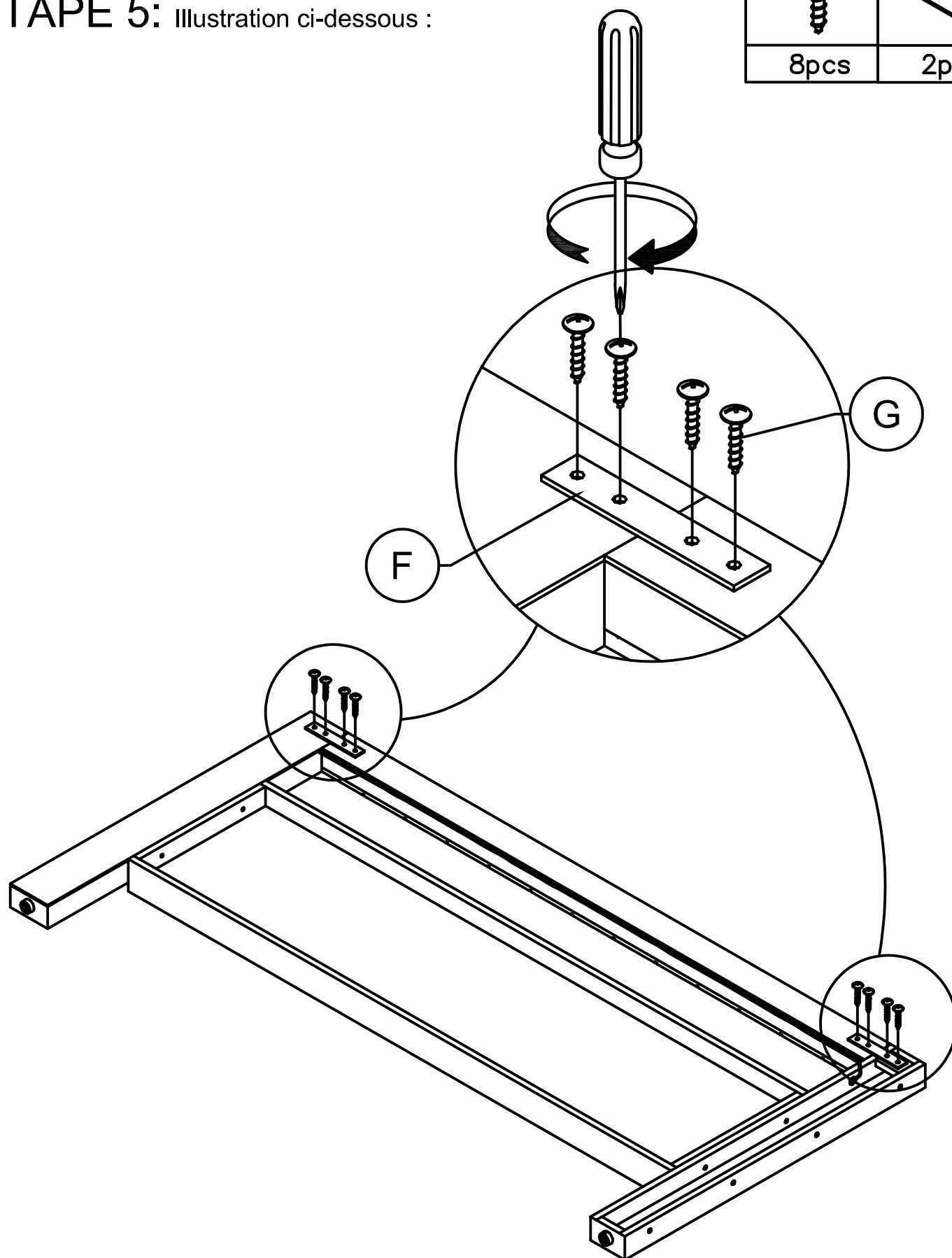

STEP 6: Following below illustration:

ÉTAPE 6: Suivant l'illustration ci-dessous :

E



4pcs

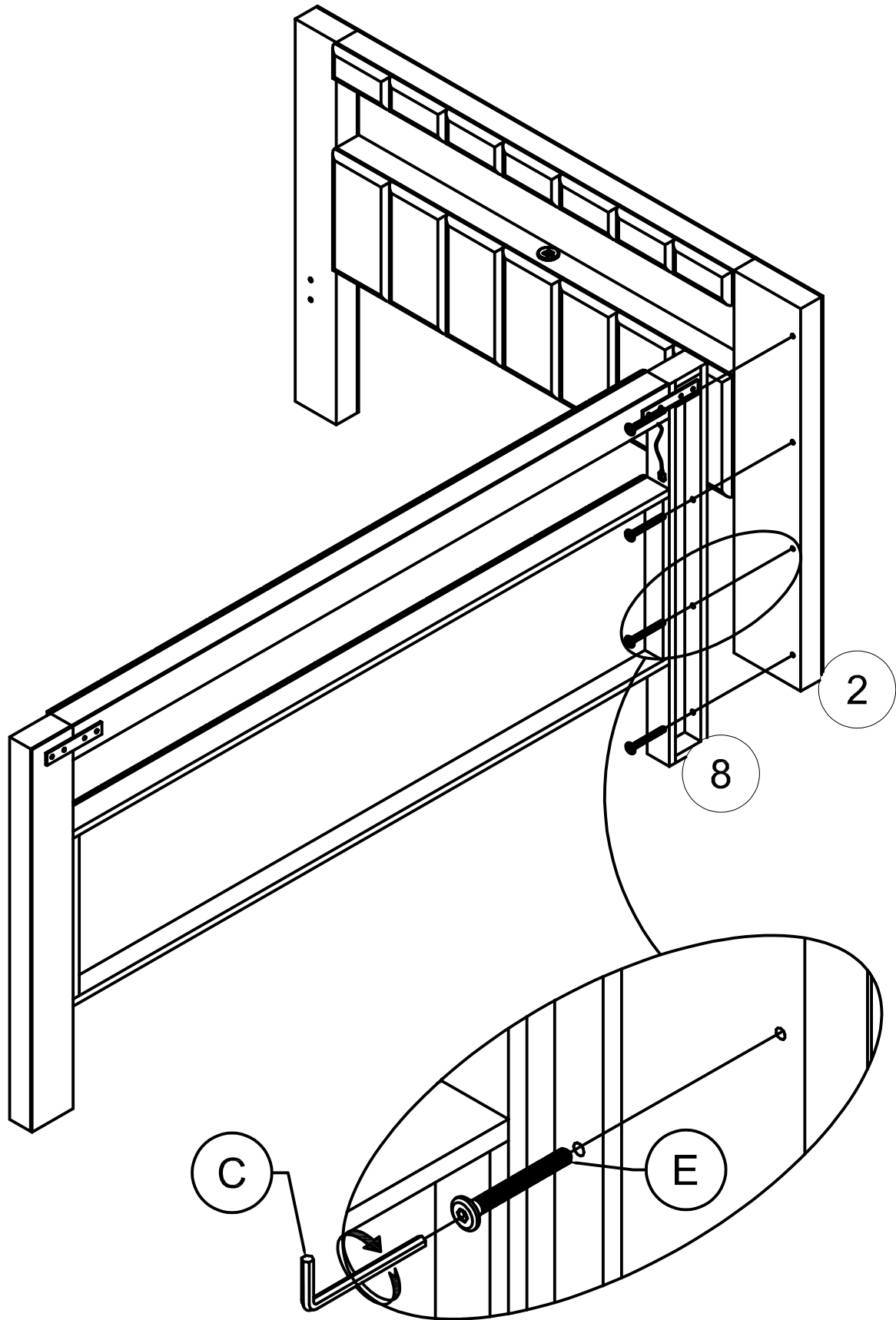

STEP 7: Following below illustration:

ÉTAPE 7: Suivant l'illustration ci-dessous :

H

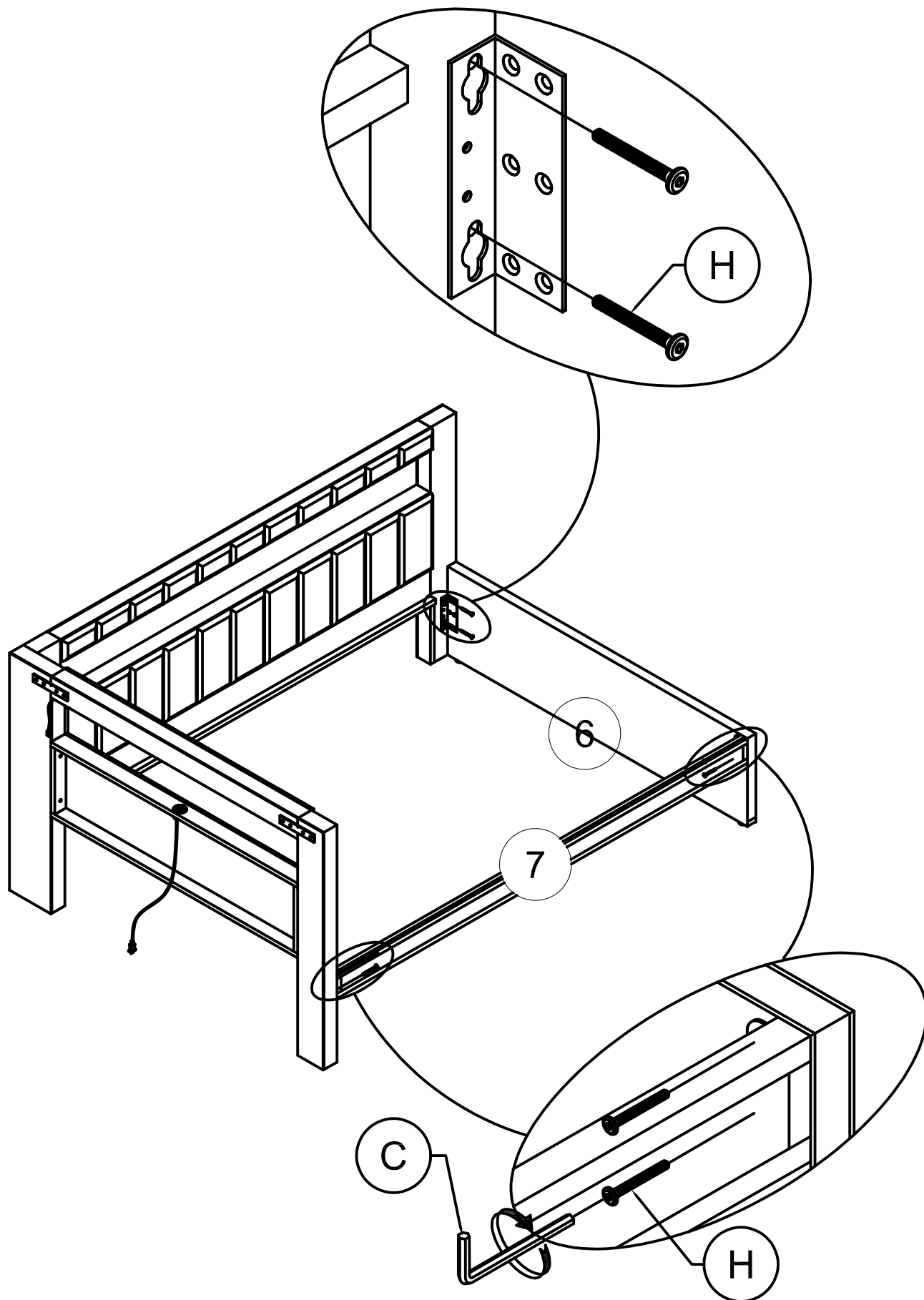
6pcs



STEP 8: Following below illustration:

ÉTAPE 8: Illustration ci-dessous :

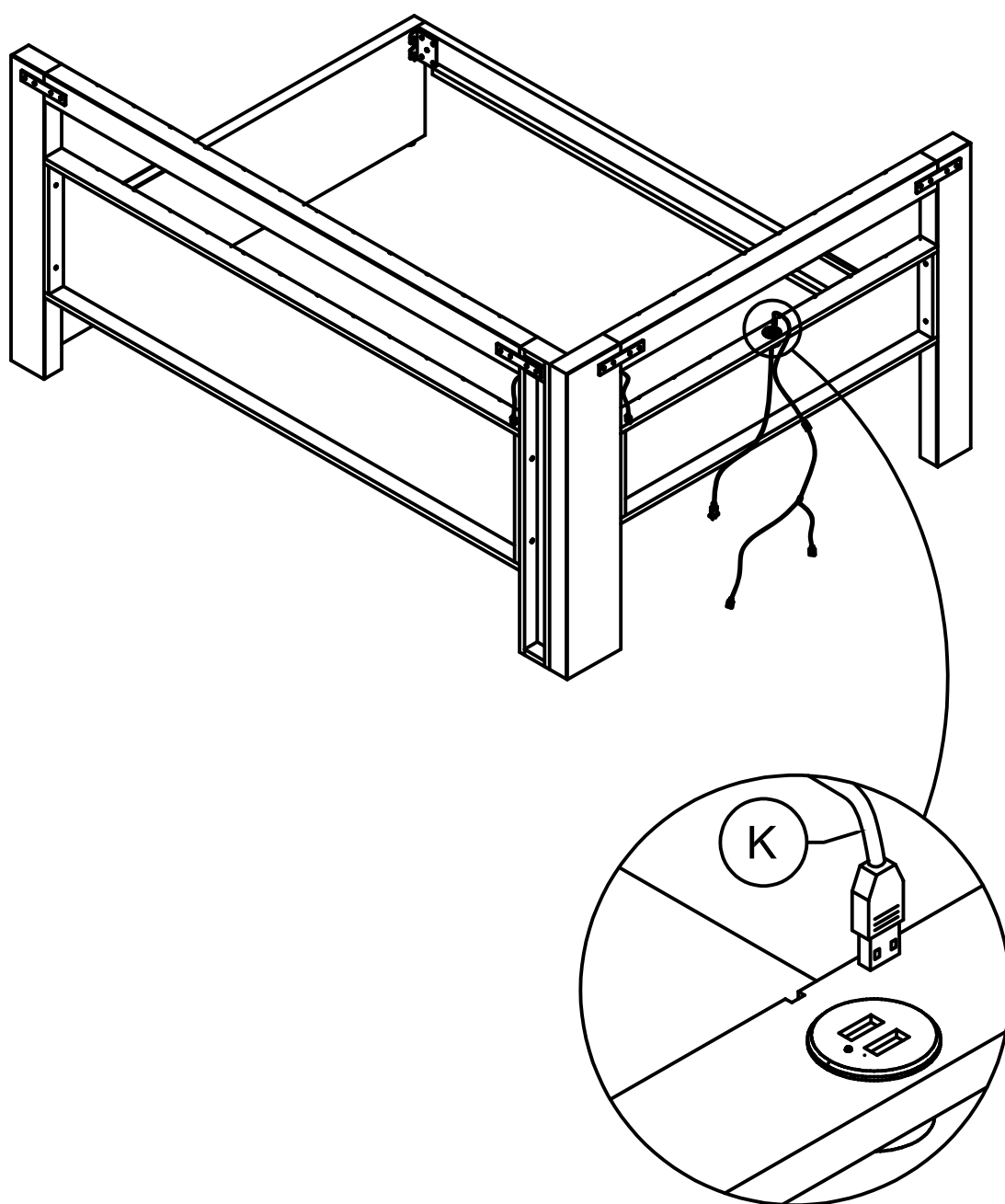
K

1pc



STEP 9: Following below illustration:

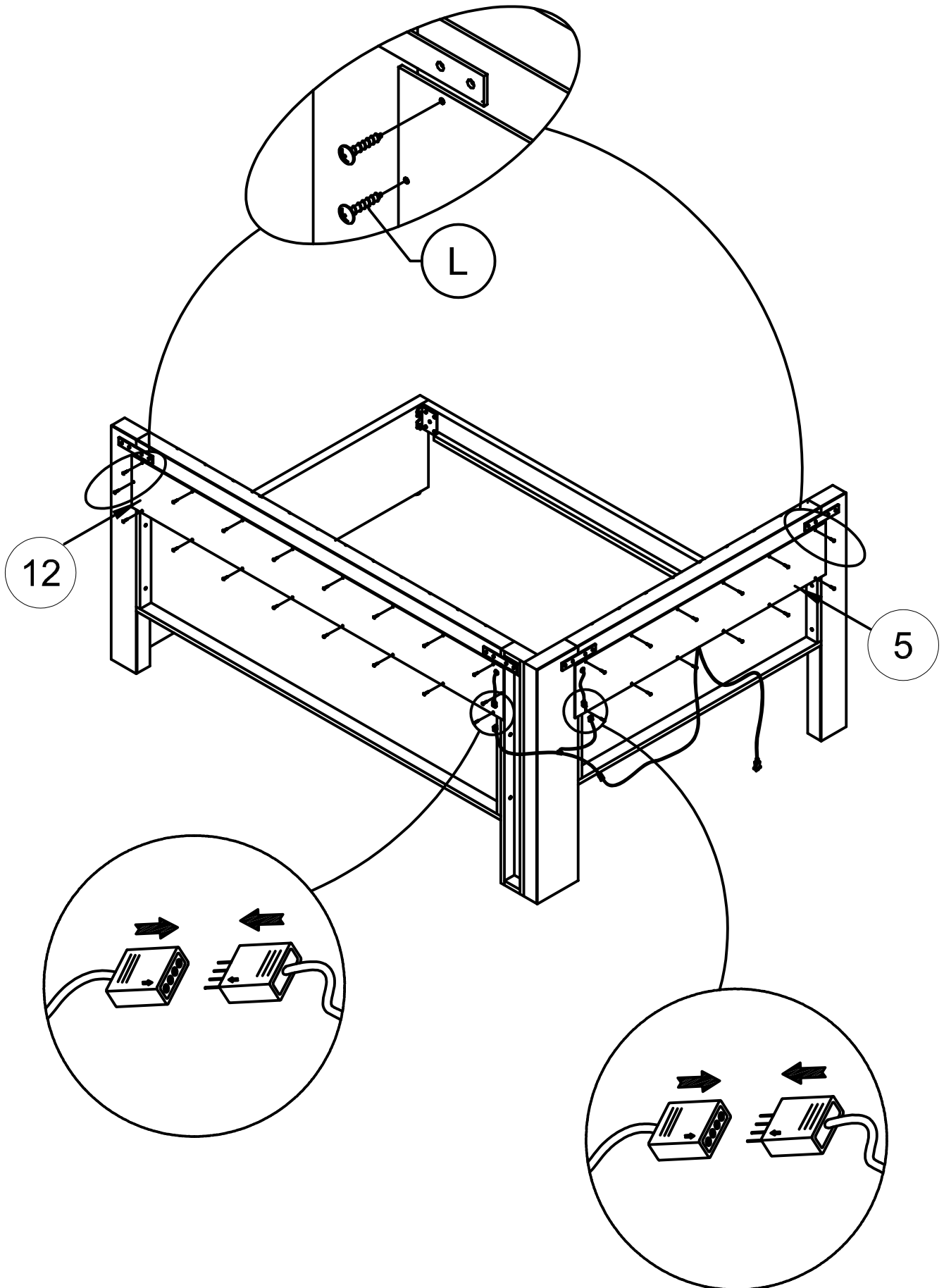

ÉTAPE 9: Illustration ci-dessous :

L	
30pcs	



STEP 10: Following below illustration:

ÉTAPE 10: Illustration ci-dessous :

P-A	P-B
	
2set	2set

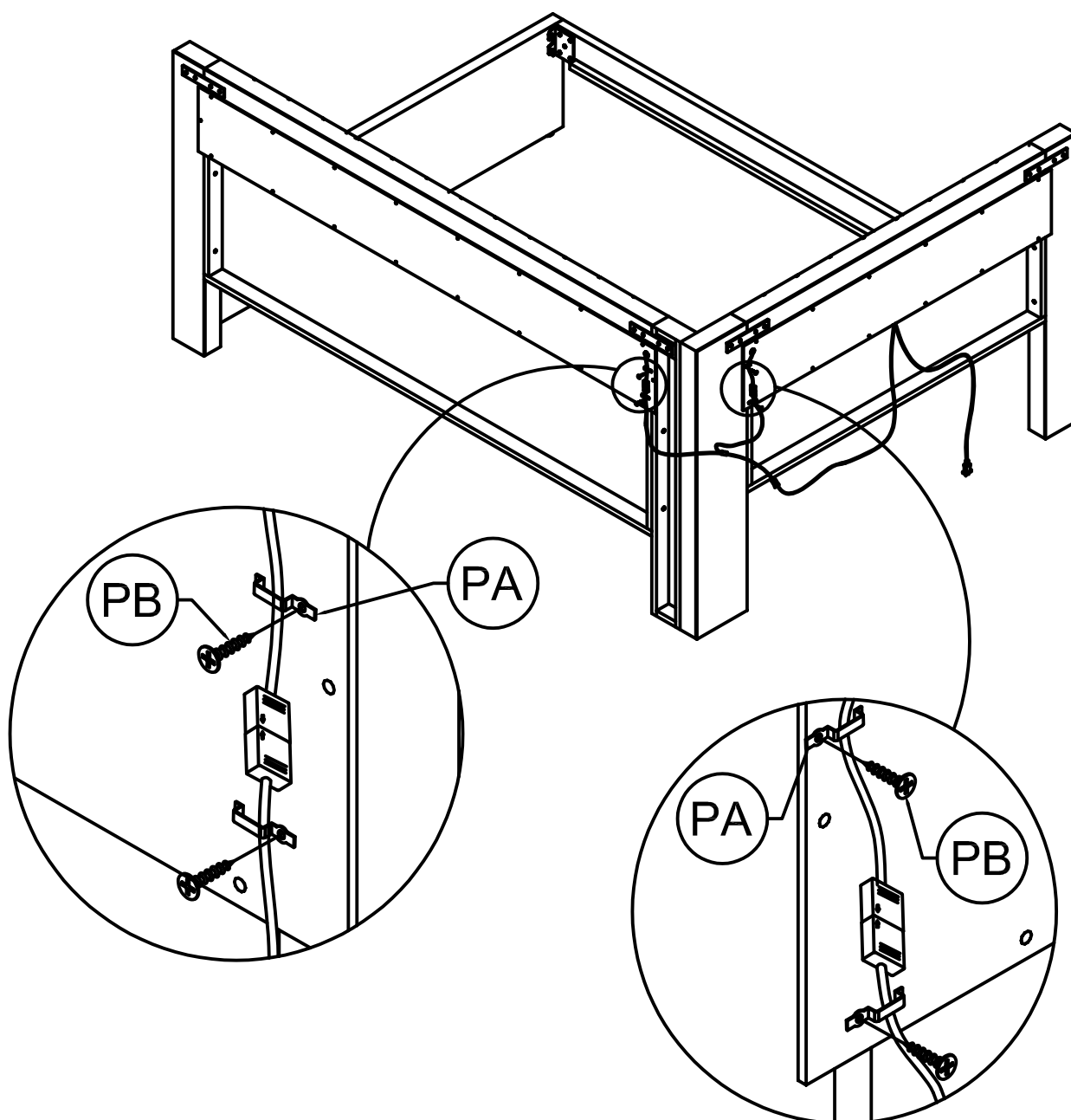

STEP 11: Following below illustration:

ÉTAPE 11: Illustration ci-dessous :

E

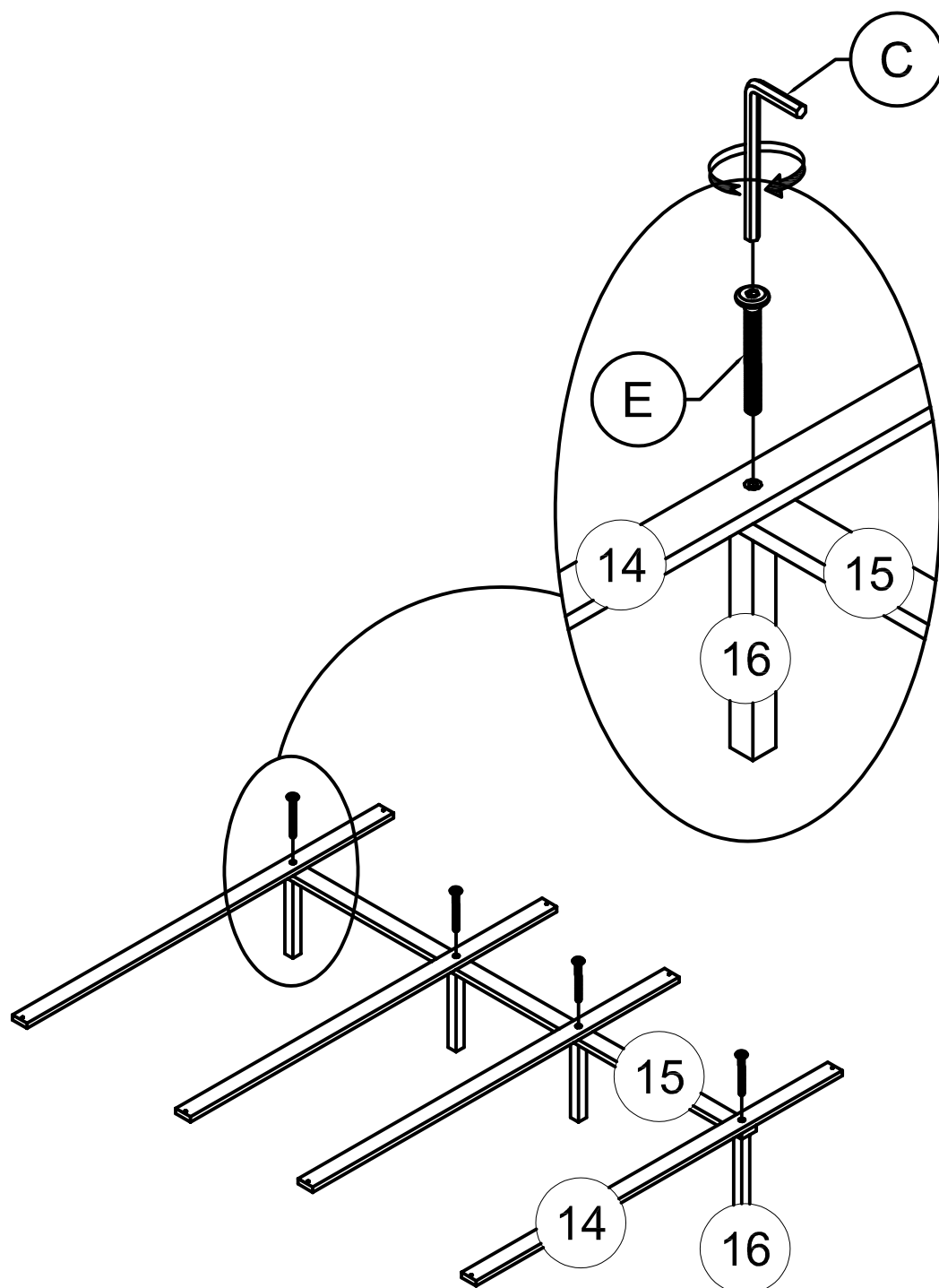
4pcs



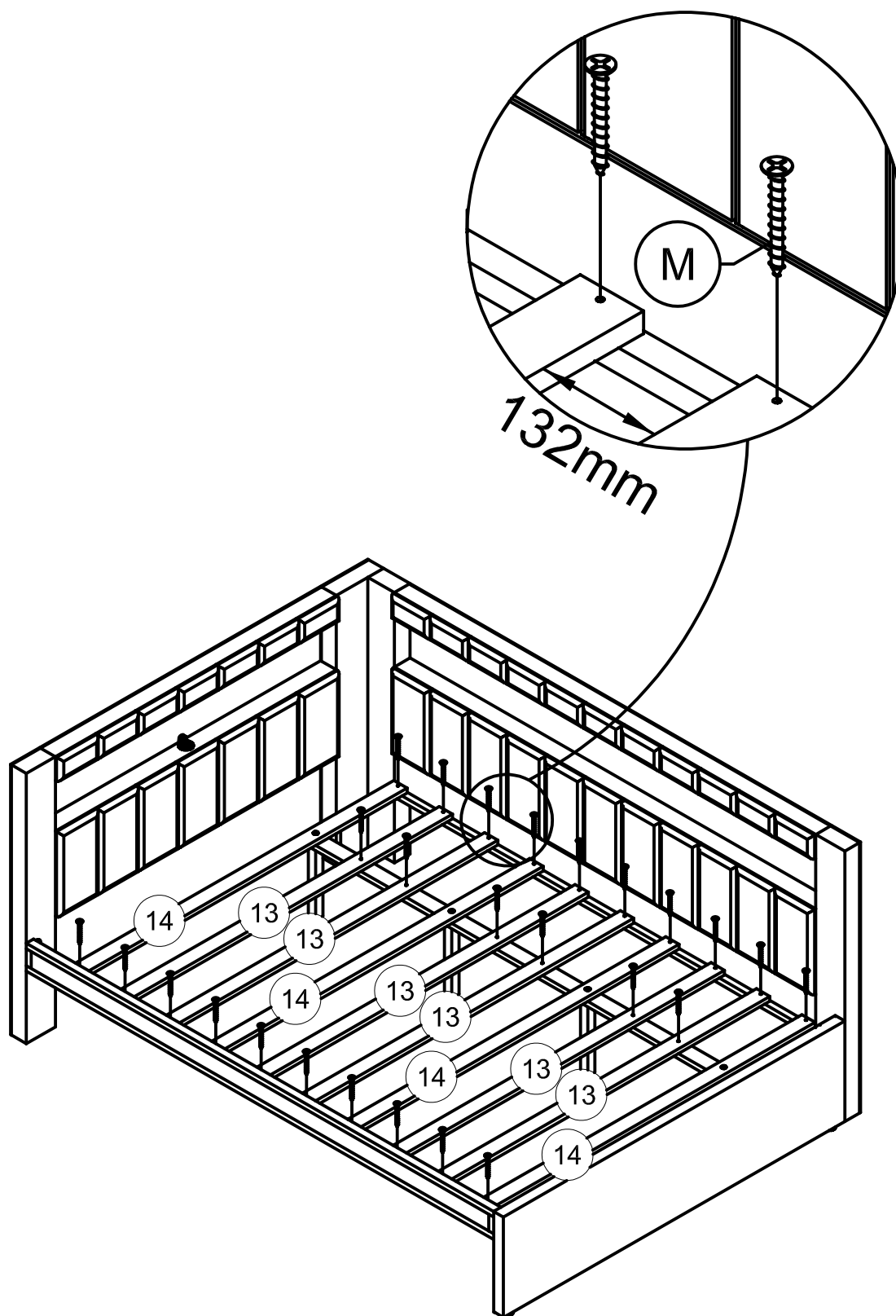
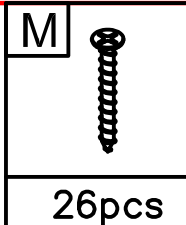

STEP 12: Following below illustration:

ÉTAPE 12: Illustration ci-dessous :



STEP 13: Following below illustration:

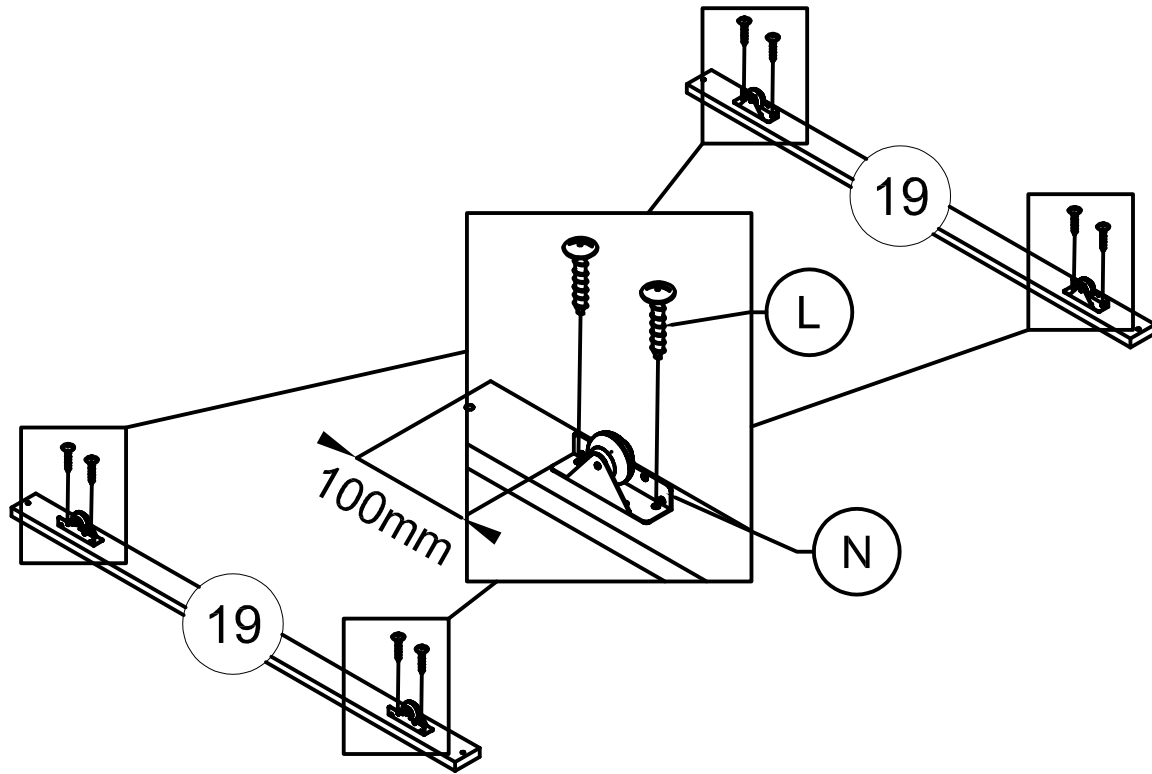

ÉTAPE 13: Illustration ci-dessous :

N	L
	
4pcs	8pcs



STEP 14: Following below illustration:

ÉTAPE 14: Illustration ci-dessous :

O	L	M
		
3pcs	12pcs	20pcs

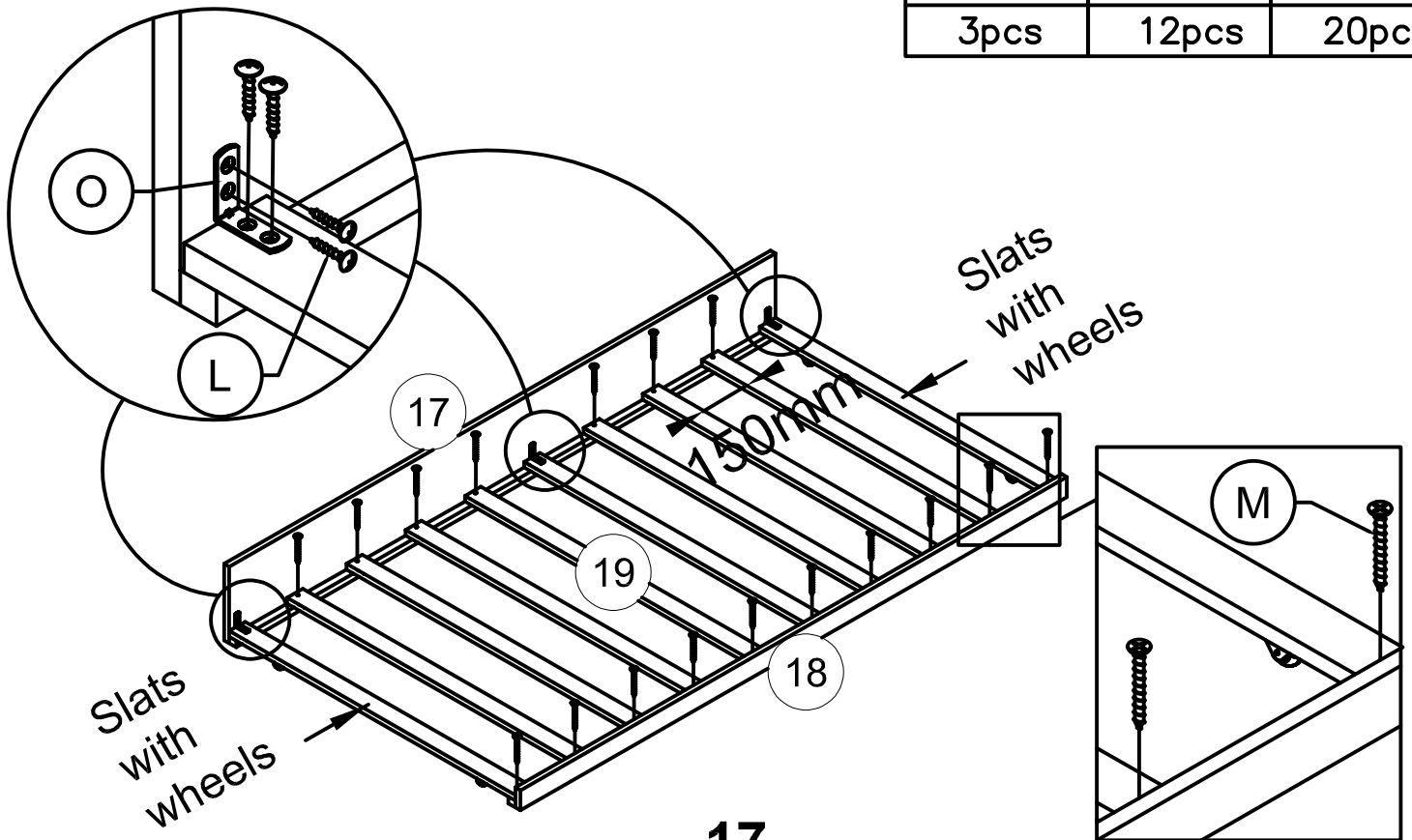

STEP 15: Following below illustration:

ÉTAPE 15: Illustration ci-dessous :

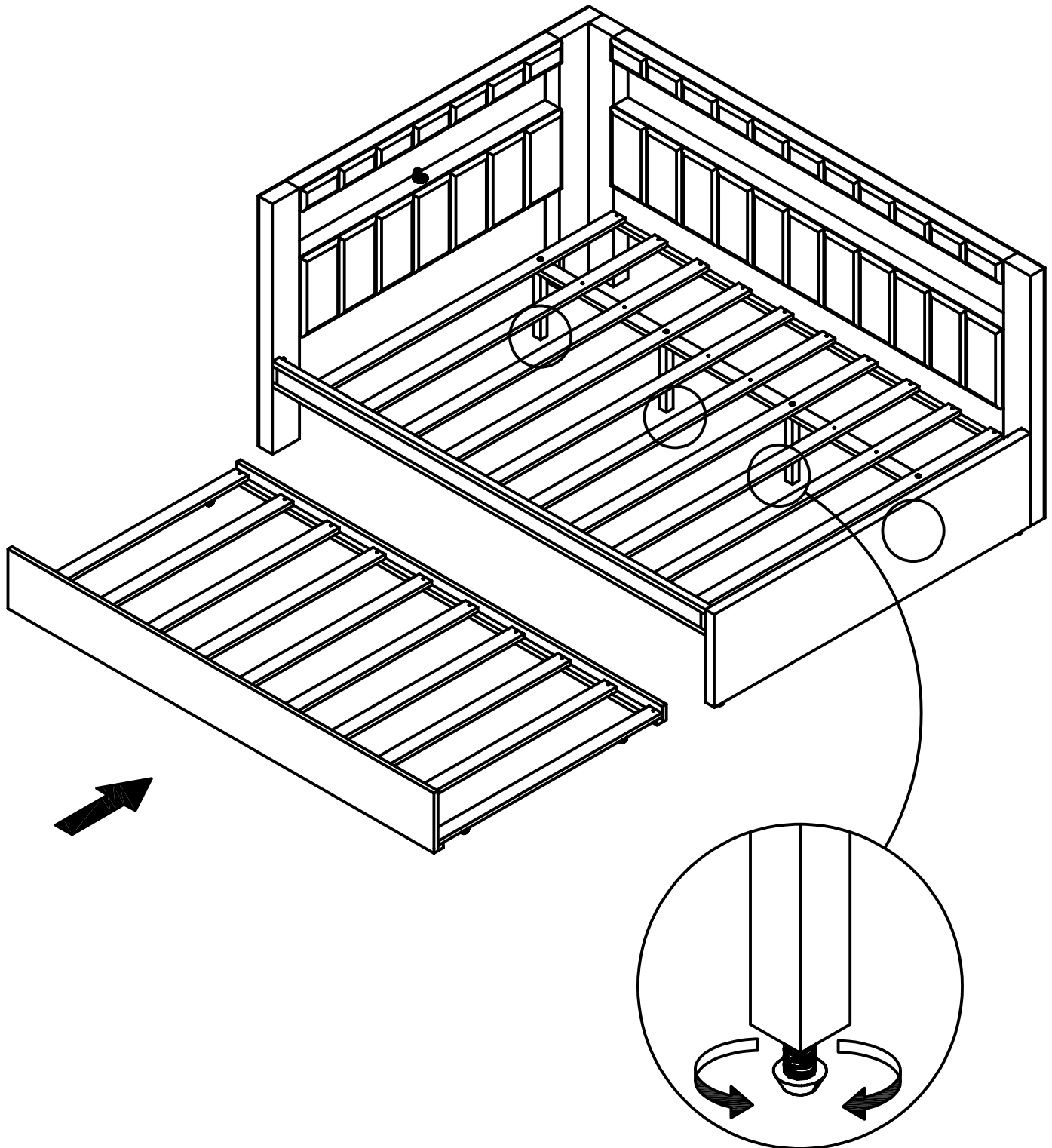

Rotate counterclockwise to increase the length of Floor Leveler, and raise that corner. Rotate clockwise to lower that corner.

Make sure to tighten all the screws of the bed.

FINISH

