

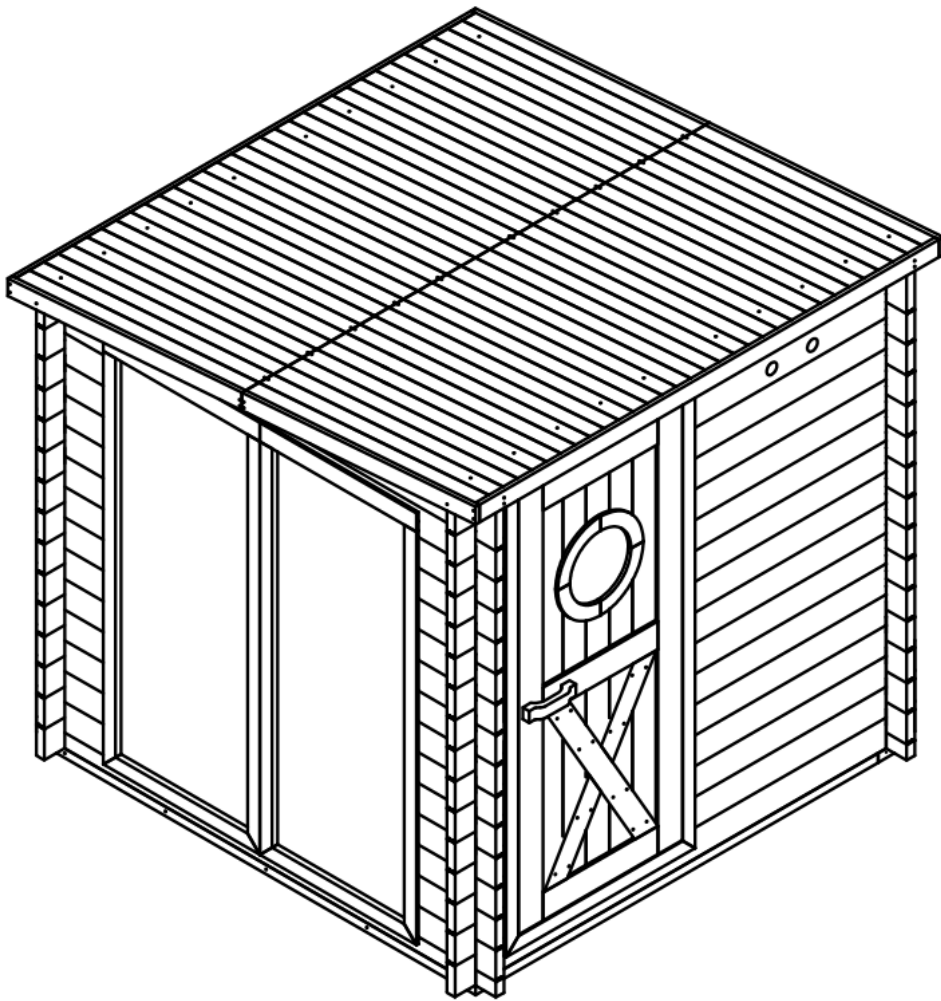

REDWOOD
OUTDOORS

Garden Sauna



(SN-C-T8)
(SN-CBU-H8K002F)

Installation & Owner's Manual



Important Information

Safety and Assembly

Please read and understand the complete instructions prior to assembly and use of your sauna. The customer agrees not to hold Redwood Outdoors or any of its authorized dealers liable for improper installation, maintenance, and repair of this product.

Our sauna kits are designed for ease of assembly and every attempt has been made to make assembly information as clear as possible. If you have any questions about assembly, please do not hesitate to call us at 1800-567-8036 or send us an email at support@redwoodoutdoors.com.

Thank you again for choosing Redwood Outdoors. We are grateful for your business and know you will have many years of enjoyment in your sauna!

Electrical Requirements

All electrical heater wiring must be performed by **A QUALIFIED LICENSED ELECTRICIAN**. Use copper wire with 90C insulation. Do not use aluminum wire to make the connection. Consult with an electrician so you can determine the requirements for your situation. All wiring must conform to all national, state, and local codes and regulations. For further information and instructions on your heater installation and operation, please consult the heater manuals on our website. (www.redwoodoutdoors.com/assembly/electric-sauna-heaters).

Choose a Site With a Strong and Level Foundation

It is important to choose a site that has a level, strong, and stable foundation. This is critical because a sauna with several bathers inside can weigh over 1,000 lbs. A deck or concrete pad (patio) are both excellent options for your sauna. If you will be placing the sauna directly on the ground, we recommend you rest the support cradles atop concrete pavers to prevent the cradles from settling into the ground. This could result in the sauna not sitting level and may cause issues over time. If your sauna comes with a ground-frame rather than cradles, we recommend installing a moisture barrier under the ground-frame.

Concrete Pads

If constructed properly (compacted well and leveled), a concrete pad will maximize the life of your sauna. The concrete pad should be at least 4" thick and reinforced with mesh to minimize cracking. We recommend constructing the pad significantly larger than needed for the sauna alone, as this will allow room for a cool down area, where you could put chairs and an outdoor shower or cold plunge tub. There is a wealth of information available online with instructions on how to design and pour a concrete pad.

Deck Installations

If you choose to install your sauna on a deck, be sure that your deck has been designed to support the weight of a full sauna (over 1,000 lbs). We recommend you have the deck inspected by a qualified architect or building engineer prior to proceeding.



REDWOOD
OUTDOORS





Installation & Owner's Manual

CONTENTS

Required Tools	02
Parts List	03
Dimensions	07
Base Assembly	08
Floor Assembly	10
Body Assembly	12
Interior Assembly	19
Heater Installation	24
Roof Assembly	27
Exterior Finishing	30
Shingle Assembly	31
Interior Finishing	35
Maintenance	36
Warranty	38
User Guide	39
Important Notice	42

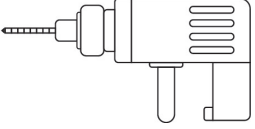
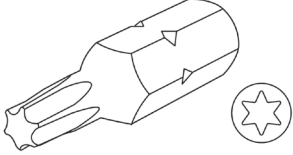
Required Tools

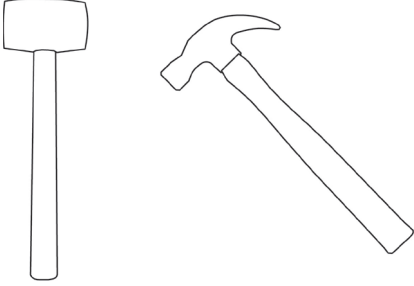
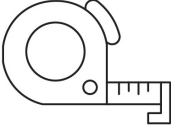
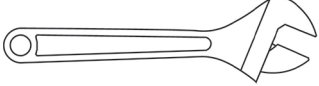
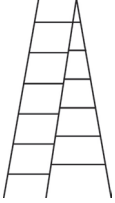
You will need the following tools to assemble the sauna:







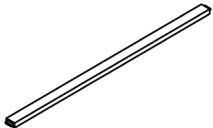
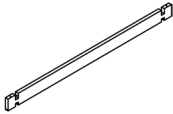
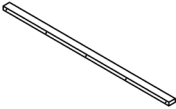
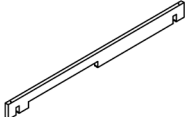
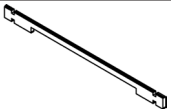
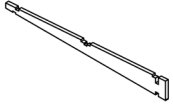
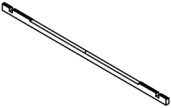

	Power drill
	Torx drill bit
	Spirit level
	Hammer & rubber mallet
	Tape measure
	Crescent wrench
	Ladder
	Gloves

Parts List

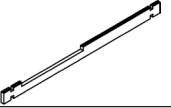
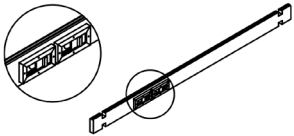
We are constantly working to improve our products. As a result of ongoing design improvement, the sauna you receive may vary slightly from the description below. + symbol indicates spare pieces. (e.g. +1 means 1 spare)

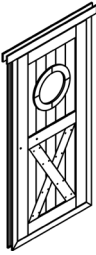
When you open the crate, if any parts are damaged, take pictures of the damage (ideally while still in the crate). Email the pictures as well as a list of which parts are damaged (e.g., 2-B, 18, etc.) to our Customer Support team (support@redwoodoutdoors.com). Our Customer Service team will assist you with next steps.

● Main Parts

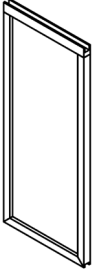





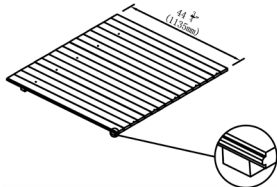
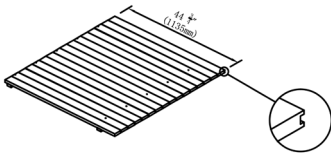

Part	Description	Qty	Part	Description	Qty
1		2PCS	16-A	Intentionally blank	
2	Intentionally blank		17-A		1PC
3-A		2PCS			
4	Intentionally blank		18-B		1PC
5	Intentionally blank		19-A	Intentionally blank	
6-A		1PC	20-B		2PCS
7-A		1PC	21-A		1PC
8-A		1PC	22-A	Intentionally blank	
9-B		1PC	23-A		1PC
10-A		27+1PCS	24-A		1PC
11-A		14+1PCS			
12-A		13+1PCS			
13-A		26+1PCS	25-A		2PCS
14-A	Intentionally blank				
15-A	Intentionally blank				

Parts List

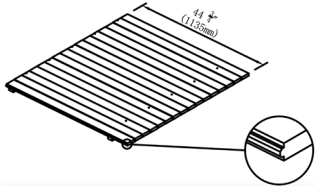

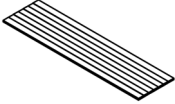
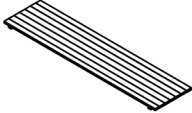
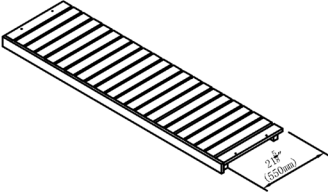
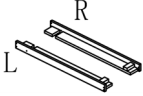
We are constantly working to improve our products. As a result of ongoing design improvement, the sauna you receive may vary slightly from the description below. + symbol indicates spare pieces. (e.g. +1 means 1 spare)

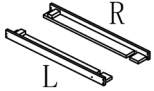
When you open the crate, if any parts are damaged, take pictures of the damage (ideally while still in the crate). Email the pictures as well as a list of which parts are damaged (e.g., 2-B, 18, etc.) to our Customer Support team (support@redwoodoutdoors.com). Our Customer Service team will assist you with next steps.

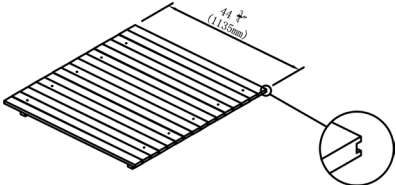
● Main Parts

Part	Description	Qty	Part	Description	Qty			
26		1PC	41-A		1PC			
27-A	Intentionally blank	1PC		42-B		1PC		
28-A		1PC			43-B		1PC	
29-A		1PC				44-A	Intentionally blank	
30	Intentionally blank		45-A	Intentionally blank				
31	Intentionally blank			46-A				1PC
32	Intentionally blank		47		Intentionally blank			
33-A		2PCS	48	Intentionally blank				
			34-A		2PCS	49	Intentionally blank	
35-A	Intentionally blank					50-A		1PC
36-B		2PCS	51		1PC			
37-B		2PCS						
38	Intentionally blank							
39-A		2PCS						
40-A		1PC						

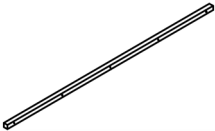
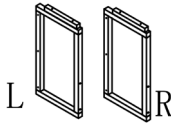
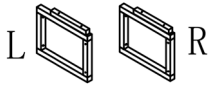

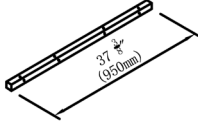
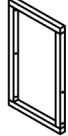
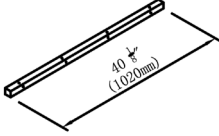
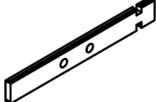
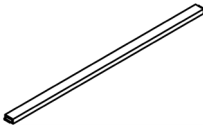
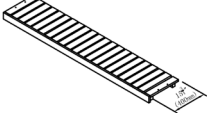













Part	Description	Qty	Part	Description	Qty
53		1PC	58-A		2PCS
54-B		2PCS	59-B		2PCS
55-B		8PCS	60-A		2PCS
56-A		8PCS	61		1PC
57		3PCS	62		1PC

Parts List

We are constantly working to improve our products. As a result of ongoing design improvement, the sauna you receive may vary slightly from the description below. + symbol indicates spare pieces. (e.g. +1 means 1 spare)

When you open the crate, if any parts are damaged, take pictures of the damage (ideally while still in the crate). Email the pictures as well as a list of which parts are damaged (e.g., 2-B, 18, etc.) to our Customer Support team (support@redwoodoutdoors.com). Our Customer Service team will assist you with next steps.

● Accessories

Part	Description	Qty	Part	Description	Qty
A	 #8x $\frac{3}{4}$ " (4x20mm)	80PCS	I	 #10x4 $\frac{3}{4}$ " (5x120mm)	2PCS
B	 #8x1 $\frac{3}{8}$ " (4x35mm)	40PCS	J	 #12x3 $\frac{1}{8}$ " (6x80mm)	2PCS
C	Intentionally blank		K	 #12x3 $\frac{3}{4}$ " (6x95mm)	8PCS
D	 #8x1 $\frac{1}{2}$ " (4x40mm)	46PCS	L	 1 $\frac{1}{2}$ " (40mm)	50PCS
E	 #8x2" (4x50mm)	128PCS	M	Intentionally blank	
F	 #8x2 $\frac{1}{2}$ " (4x60mm)	10PCS	N	Intentionally blank	
G	 #10x2 $\frac{3}{4}$ " (5x70mm)	31PCS	O	Intentionally blank	
H	 #10x4" (5x100mm)	18PCS	P		1PC
			Q	 93"x39 $\frac{3}{8}$ " (2360x1000mm)	3PCS
			R	 90 $\frac{3}{4}$ "x90 $\frac{3}{4}$ " (2305x2305mm)	1PC

Dimensions

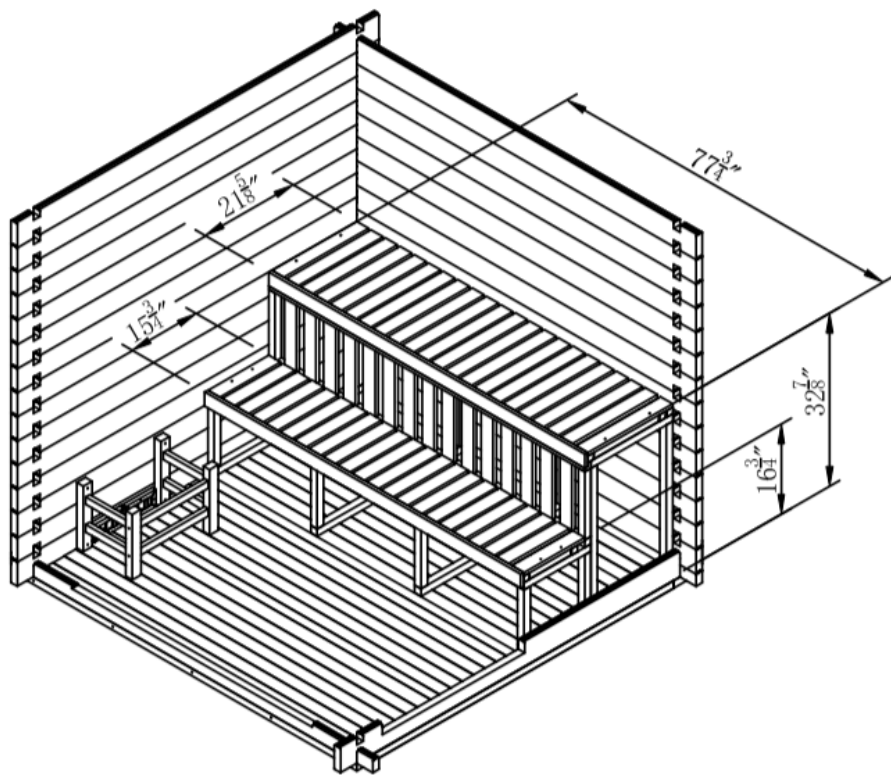
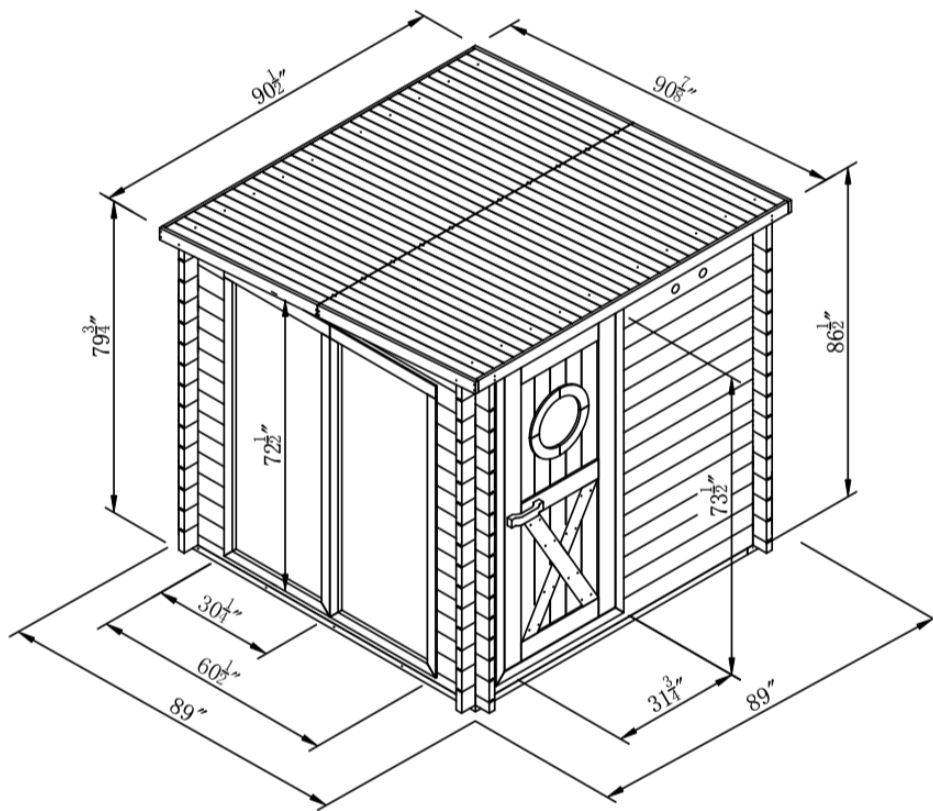

Base Assembly

Step 1: Assemble the Ground Frame



Lay the ground frame pieces on the foundation. The pieces are treated with wood wax oil to protect against rot. We recommend placing a polyethylene moisture/vapor barrier under the ground frame to protect the sauna from moisture.

Ensure the frame is level, if it is not, you may have issues closing the door.

Insert the cross pieces into the end pieces and fasten them. The ground frame is made of yellow cedar, which is durable and **very hard**. As a result, you may need to remove/reinsert the screws multiple times before they sink into the frame. You **must use a drill bit extension** to reach inside the pre-dilled pocket hole.

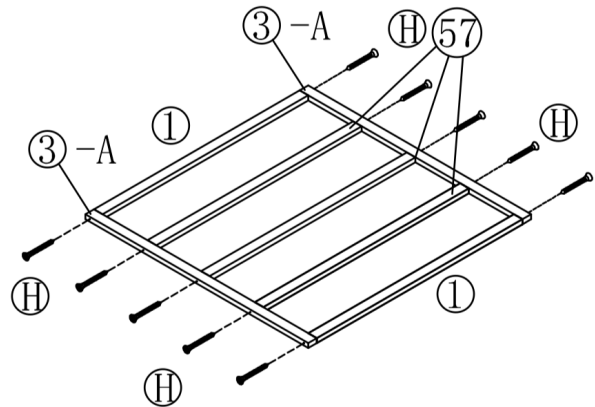
Make sure the ground frame is square measuring from corner to corner.

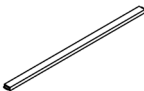
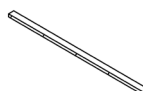

1	3-A	57	H
			 #10x4" (5x100mm)

Base Assembly

Step 2: Place the First Layer

Lay the half-cut beams (i.e., beams with one side grooved and one side flat) across the frame. The beams will extend past the edge by 4".

Make sure the beams are flush with the frame. The #8 & #9 beams will lock into place on the #7 & #21 beams.

Reconfirm that the beams are level on the frame. The #7 beam is cut for the large windows. The #8 beam is cut for the door. Confirm they are in the right locations.

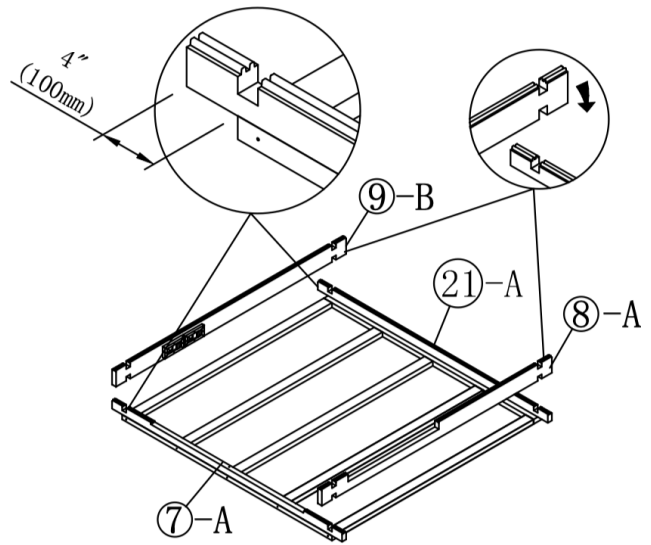

7-A	8-A	9-B	21-A

Floor Assembly



Step 3: Install the Floor and Fasten the First Layer of Beams

Before securing the first layer of beams into place, lay the floor pieces inside the frame. Fit the pieces together loosely to allow space for them to expand when wet. If you have a gap between your floorboard and the wall, your floorboards are packed too tightly. Space the floorboards so that the gap is evenly distributed.

The connecting piece under the #33 floor pieces does not extend to the edge on both sides. Place the floor boards on the base so that notch is facing the outside of the sauna (i.e., touching the side walls). Refer to the diagram on the right.

Once the floor has been laid, confirm that the first layer is flush with the sides of the ground frame, then fasten them to the ground frame.

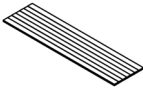
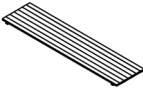
Use the **shorter G screws** to fasten the half-cut beams and the **longer H screws** to fasten the full-size beams.

33-A	34-A	G	H
			
		#10x2 ³ / ₄ " (5x70mm)	#10x4" (5x100mm)

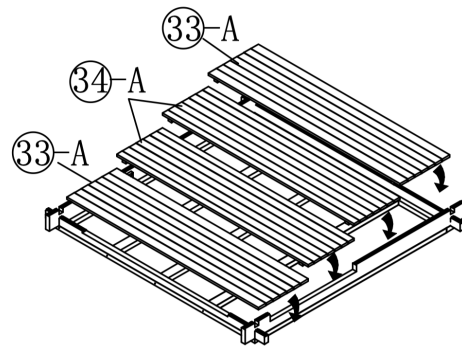

View from below

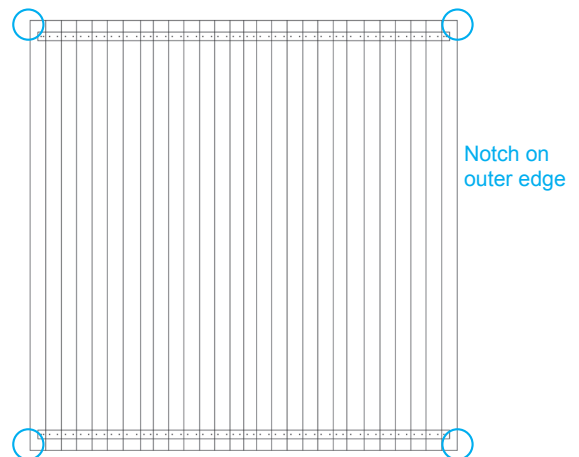

Notch on outer edge

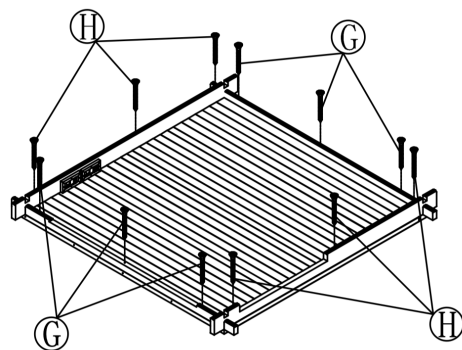

Floor Assembly

Step 4: Fasten the Floor

Fasten the floor along the middle and sides carefully with your hammer, taking care to not hit the beams too hard as the kiln dried wood is brittle and may crack.

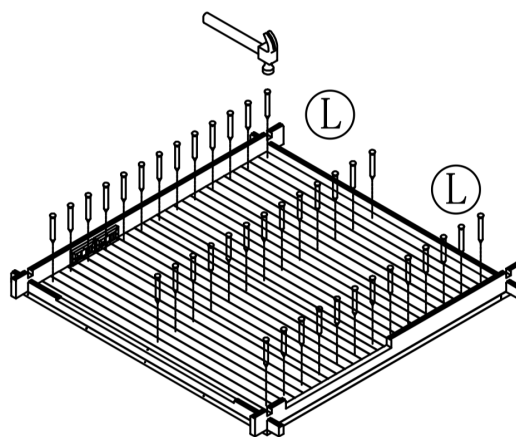
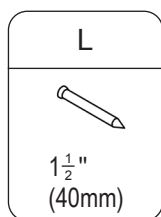

Body Assembly

Step 5: Build Up The Side Walls

Place beams onto the frame to build up the walls. After the first layer, the beams do not need to be fastened to the layer below.

The ribs on the top of the beam fit together with the divots on the bottom of the next beam. If you are having fit issues, use the hammer block (piece 46) to work them into place. You can also turn the beam 180 degrees and install it “backward” as this may lead to a smoother fit.

Follow the beam numbers shown in the diagram. Build up using the #10, #11, #12, and #13 beams.

Handle the beams with care. The wood is kiln-dried and brittle. If beams are dropped or mishandled, they can crack or even break.

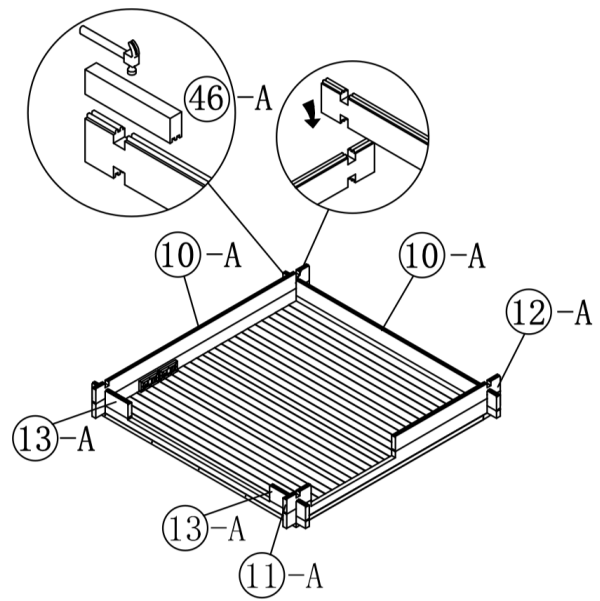





10-A	11-A	12-A	13-A	46-A

Body Assembly

Step 6: Continue Building Up the Walls

Continue building up the sauna walls using beams #10, #11, #12, and #13..

10-A	11-A	12-A
		
13-A	46-A	
		

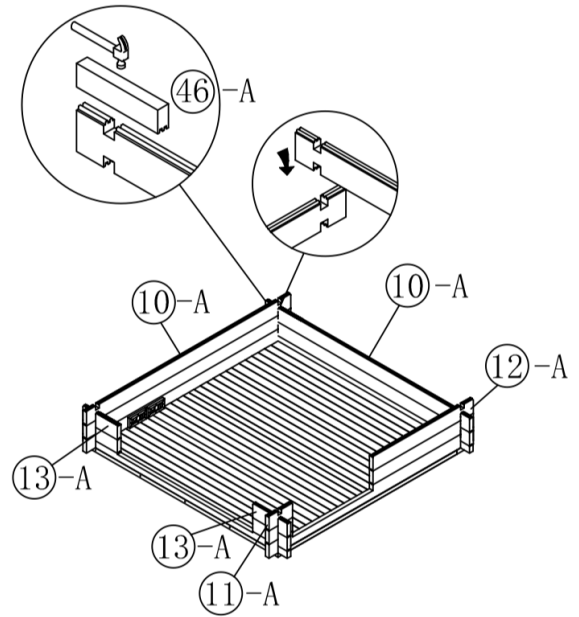



Body Assembly

Step 7: Install Door and Large Windows

Once you have 3 layers in place, put the door frame in the gap created for the door.

Next, place the windows in the gap created at the side of the sauna.

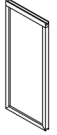
Make sure that the tops of the windows are level, then fasten the windows together using the connector piece.

24-A	25-A
	
26	D
	 #8x1½" (4x40mm)

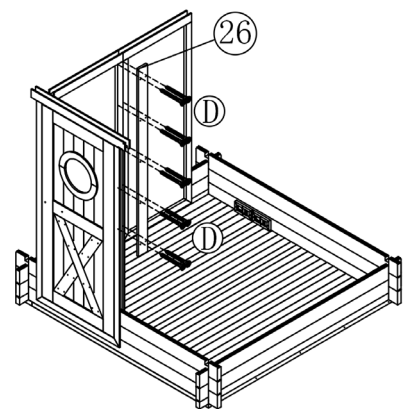
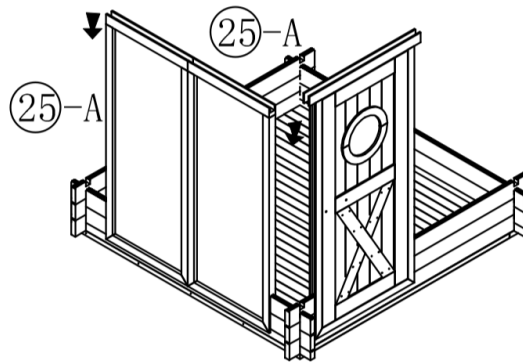
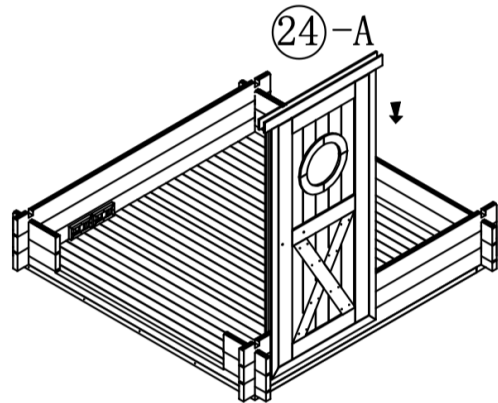





Body Assembly

Step 8: Build up the Walls

Continue building up the walls using beams #10, #11, #12, and #13.

Handle the beams with care. The wood is kiln-dried and brittle. If staves are dropped or mishandled, they can crack or even break.

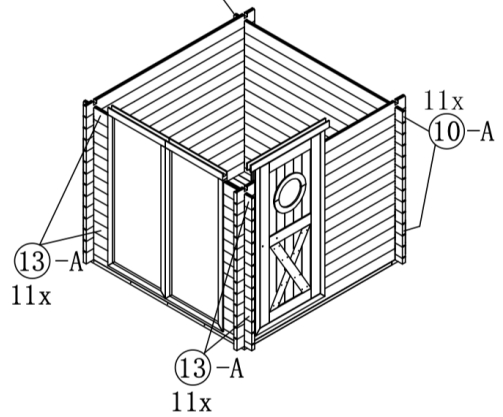
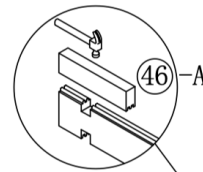
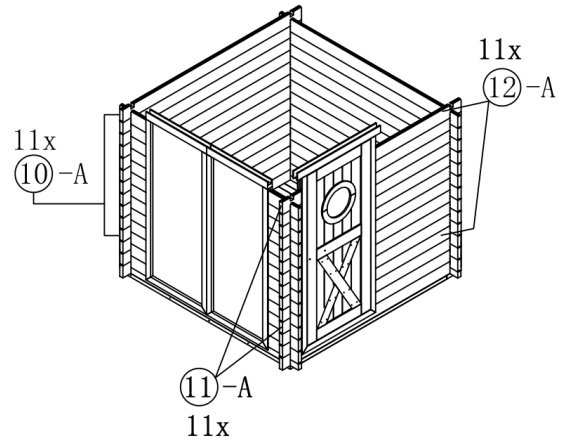

10-A 	11-A 	12-A 
13-A 	46-A 	



Body Assembly

Step 9: Install the Door Handles

Attach the door handle to the door.

28-A	29-A	J
		 #12x3 $\frac{1}{8}$ " (6x80mm)

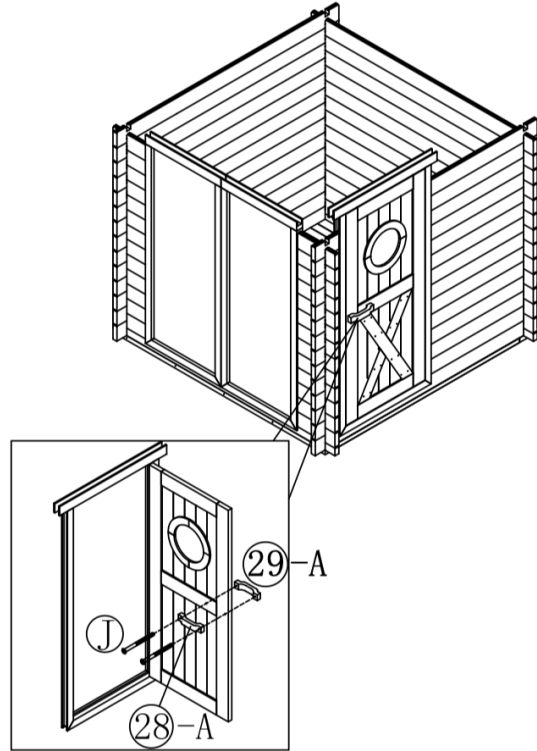

Body Assembly

Step 10: Complete the Large Windows

Beam #6 is placed over the large windows. Place it over the top of the large windows.

Place beam #17 at the back of the sauna to complete the back wall. The top of beam #17 is angled, the higher side should face the inside of the sauna (to create the slope for the roof).

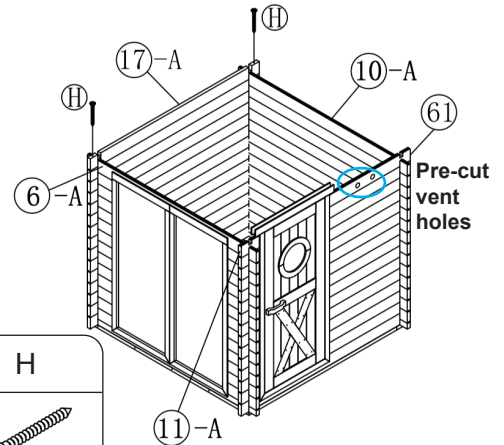

6-A	10-A	11-A	17-A	61	H
					#10x4" (5x100mm)

Step 11: Complete the Sauna Structure

Place the angled cut **#20 beams** on either side of the sauna.

Place **beam #18** at the front of the sauna to complete the walls. The top of beam #18 is angled, the lower side should face the inside of the sauna (to create the slope for the roof).

Fasten beams #18 and #20 to the beams below using the G & I screws. You **must use a drill bit extension** to reach inside the pocket hole.

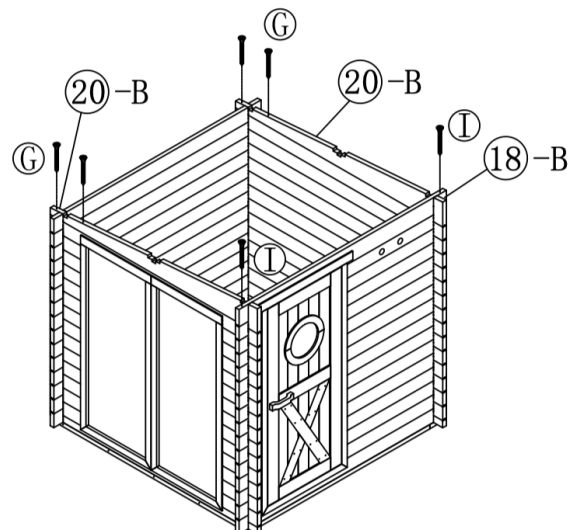

18-B	20-B	G	I
		#10x2 ³ / ₄ " (5x70mm)	#10x4 ³ / ₄ " (5x120mm)

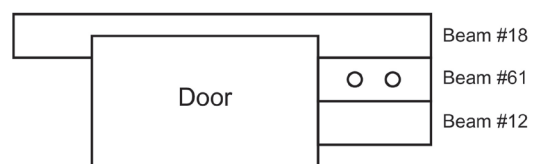

Beam Sequence Above Door

Body Assembly



Step 12: Install the Purlin

Place the purlin **beam #23** across the center of the sauna.

Fasten beam #23 to the beams below using the F screws.

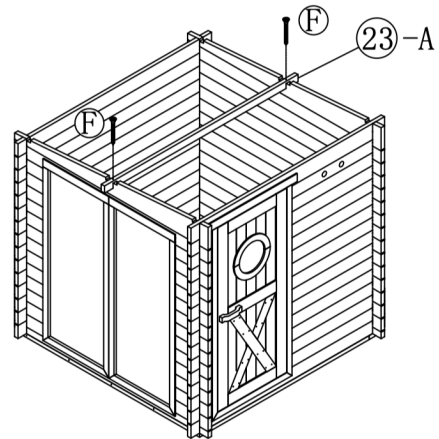
The sauna's walls are now complete. **You should have #10, #11, #12, and #13 beams left over.** If you do not have any spare beams, you have built too many layers (unless you had to use your spare due to damage).

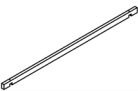

23-A	F
	
	#8x2 $\frac{1}{2}$ " (4x60mm)

Interior Assembly

Step 13: Assemble the Left and Right Bench Frames

Use the nuts and bolts to fasten the two pieces of the support frame together. Make sure the nuts are tight.

Once assembled, the support frames should form an L-shape. The left and right frames have wood blocks at the top, but the center frames do not.

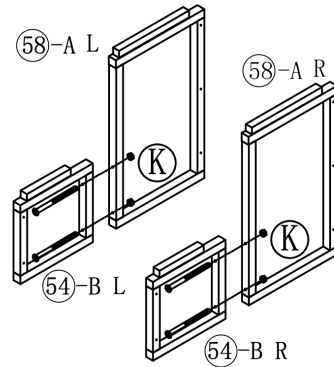

54-B	58-A	K
		#12x3 ³ / ₄ " (6x95mm)

Step 14: Place the Left and Right Bench Frames

Place the left frame against the left sauna wall. Place the right against the right sauna wall. The bottom corners should be snug in the bottom corner of the sauna.

Fasten the frames to the side walls following the pre-drilled hole pattern.

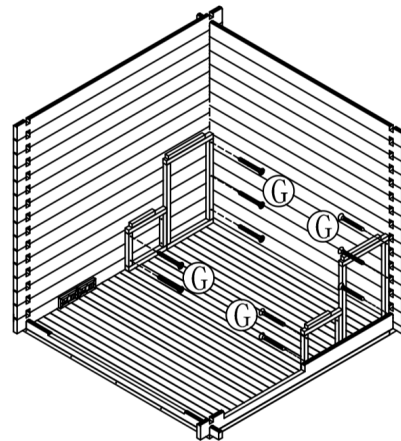

G
#10x2 ³ / ₄ " (5x70mm)

Interior Assembly

Step 15: Assemble the Center Bench Frames

Use the nuts and bolts to fasten the two pieces of the support frame together. Make sure the nuts are tight.

Once assembled, the support frames should form an L-shape. The left and right frames have wood blocks at the top, but the center frames do not.

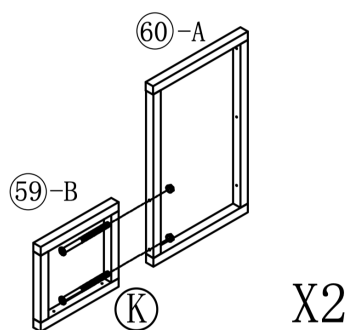

59-B	60-A	K
		#12x3 ³ / ₄ " (6x95mm)

Step 16: Place the Center Bench Frames

Place the center frames against the back sauna wall. The frame should be spaced evenly between the sauna walls, ~23 7/8" from the inside of one strut to the other. The bottom corners should be snug in the bottom corner of the sauna.

Fasten the frames to the back wall and floor following the pre-drilled hole pattern.

F	G
#8x2 ¹ / ₂ " (4x60mm)	#10x2 ³ / ₄ " (5x70mm)

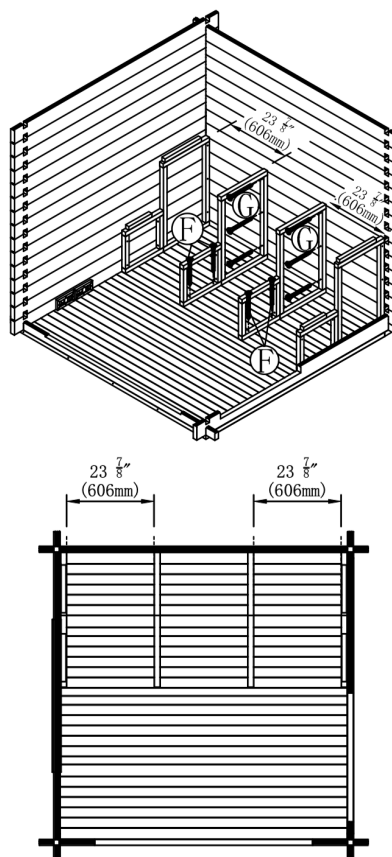



Interior Assembly

Step 17: Place the Back Cleat

Place the long cleat (#53) on top of the frames so that it runs the length of the back wall.

Make sure the cleat is level and touching all bench frames, then fasten it to the back wall with screws.

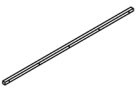
The raised pieces of the right and left frames should be on top and create a channel for the bench to sit in.

53	G
	 #10x2 $\frac{3}{4}$ " (5x70mm)

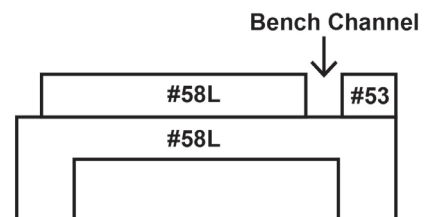
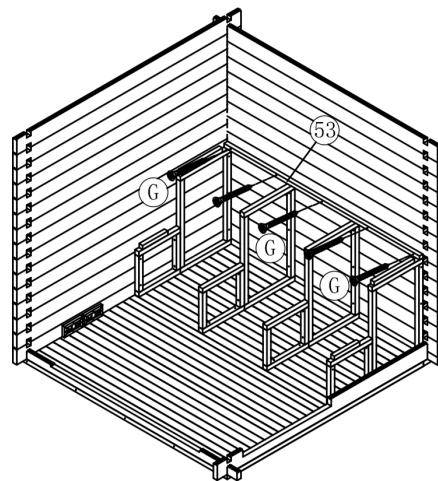

Interior Assembly

Step 18: Place the Top Bench

Place the top bench on top of the frames so that it sits in the channel between the back cleat and side frames.

Confirm that the bench is sitting flat and level. If it is not sitting flush and touching the frames on both sides, your frames may be constructed incorrectly or not level. Remove the bench and check before proceeding.

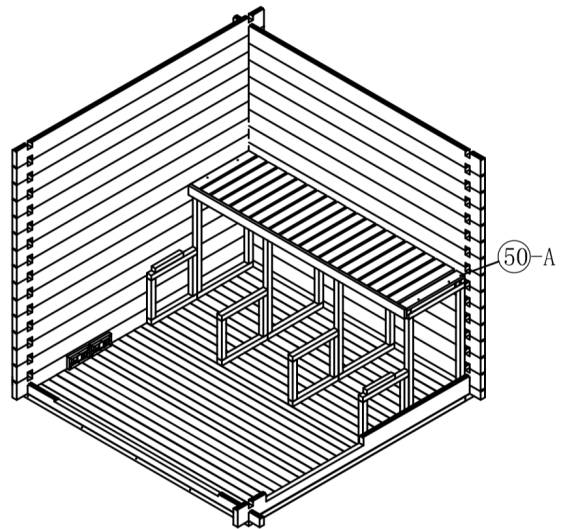
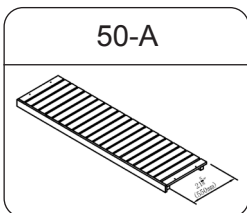

Step 19: Place the Fence

Once the top bench is placed, place the fence against the frames. The top bench will fit over the top of the top fence to keep it from falling forward.

Fasten the bench to the side frames and fasten the fence to the bench.

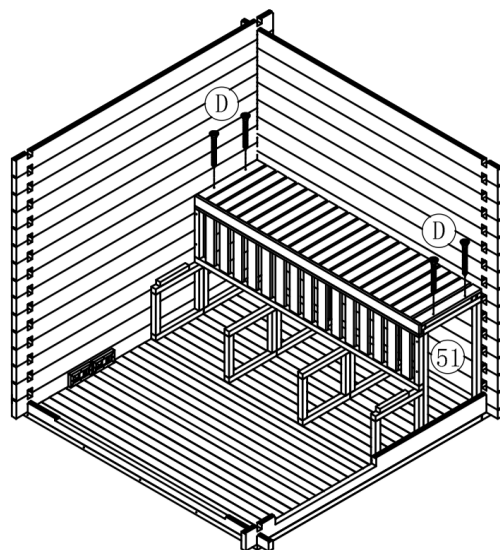
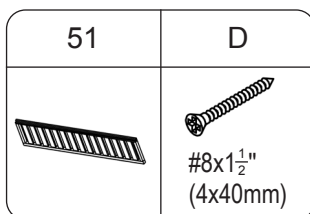

Interior Assembly



Step 20: Place the Bottom Bench

Place the bottom bench on top of the frames so that it sits in the channel between the larger frame piece and the smaller frame piece.

Confirm that the bench is sitting flat and level. If it is not sitting flush and touching the frames on both sides, your frames may be constructed incorrectly or not level. Remove the bench tops and check the frames before proceeding.

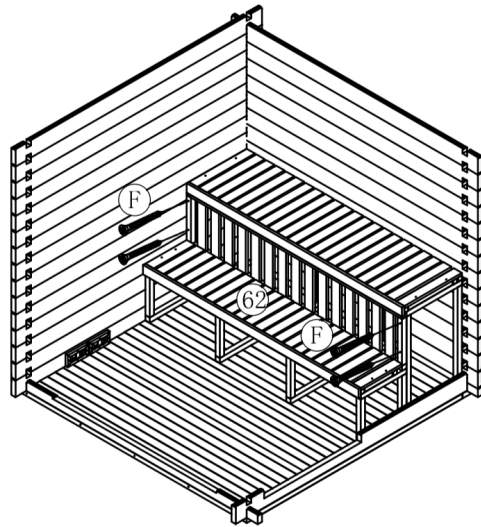
Fasten the bench to the bench supports.

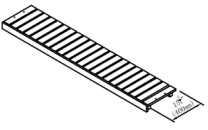

62	F
	 #8x2½" (4x60mm)

Step 21: Fasten the Lower Bench

Fasten the lower bench to the bench supports.

D
 #8x1½" (4x40mm)

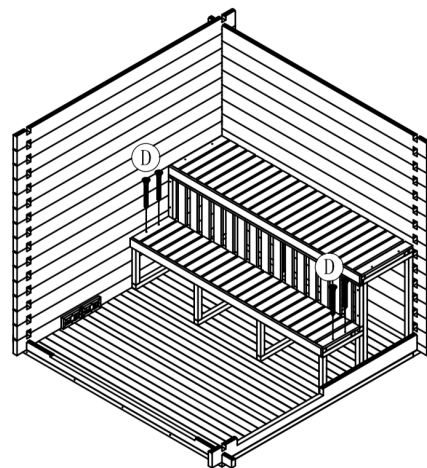

Heater Installation

Step 22a: Mount the Heater and Place the Temperature Sensor – Harvia Spirit Heaters

All electrical wiring must be performed by a **QUALIFIED LICENSED ELECTRICIAN**. Heater installation manuals are available on the Redwood Outdoors website and should be provided to your electrician before installation.

Once the heater is installed, place the heater's temperature sensor. The temperature sensor controls the temperature inside the sauna. The heater will shut off when it senses that the sauna has reached the set temperature.

For **Harvia Spirit** heaters, the mounting plate can be mounted so that the bottom sits approximately 12" off of the floor. Use the mounting hardware to secure the mounting plate to the wall of the sauna.

We recommend placing the thermometer approximately **~14" to the side of the heater, and approximately ~4" below the highest point of the sauna**. Please note that the roof is sloped, and the highest point is along the front wall where the slope is at its highest angle.

Correct temperature sensor placement is crucial to the performance and maintenance of your heater. If the sensor is placed too high or too low, your heater's internal safety switch will engage and shut off the heater before the 60 minute preheat time is finished, and your sauna may not come to temp. Incorrect temp sensor placement can also negatively affect the lifespan of your heater coils.

**If you have any questions about temp sensor placement, please contact Redwood Outdoors Customer Support for assistance.*

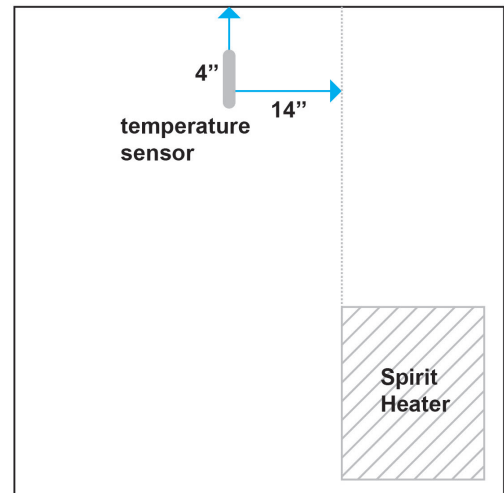

Spirit Heater Temperature Sensor Recommended Placement

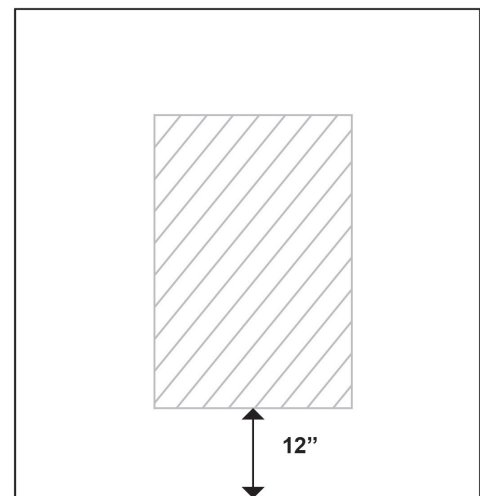

Spirit Mounting Plate Placement

Complete heater manuals are available here



Heater Installation

Step 22b: Mount the Heater and Place the Temperature Sensor – Harvia KIP Heaters

For KIP heaters, position the heater mounting screws approximately **20" off the sauna floor and spaced 15 1/4" apart**. Hang the heater on the mounting screws to ensure it is level and that its base sits **5-7" off the floor**.

All electrical wiring must be performed by **A QUALIFIED LICENSED ELECTRICIAN**. Heater installation manuals are available on the Redwood Outdoors website and should be provided to your electrician before installation.

Once the heater is installed, place the heater's temperature sensor. The temperature sensor controls the temperature inside the sauna. The heater will shut off when it senses that the sauna has reached the set temperature.

For **Harvia KIP** heaters, we recommend placing the thermometer **~14" to the side of the heater and ~14" below the ceiling's highest point**. Make sure the top of the sensor is not covered. The diagram to the right shows the recommended placement.

Correct temperature sensor placement is crucial to the performance and maintenance of your heater. If the sensor is placed too high or too low, your heater's internal safety switch will engage and shut off the heater before the 60 minute preheat time is finished, and your sauna will not come to temp. Incorrect temperature sensor placement can also negatively affect the lifespan of your heater coils.

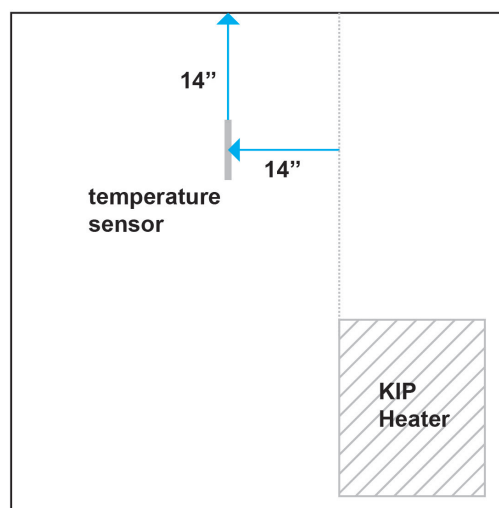

KIP Heater Temperature Sensor Recommended Placement

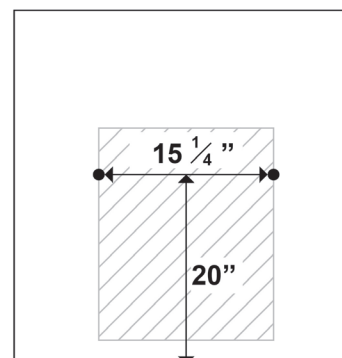

KIP Mounting Screw Placement

Heater Installation

Step 22c: Mount the Heater and Place the Temperature Sensor – Harvia Virta Heaters

All electrical wiring must be performed by a **QUALIFIED LICENSED ELECTRICIAN**. Heater installation manuals are available on the Redwood Outdoors website and should be provided to your electrician before installation.

Once the heater is installed, place the heater's temperature sensor. The temperature sensor controls the temperature inside the sauna. The heater will shut off when it senses that the sauna has reached the set temperature.

For **Harvia Virta** heaters, the heater is placed directly on the ground. Ensure that there is at least 2" of clearance on all sides. If your sauna has lower vent holes, make sure the heater is placed near them to allow adequate airflow.

We recommend placing the thermometer approximately **~18" to the side of the heater, and approximately ~18" below the highest point of the sauna**. Please note that if the roof is sloped, the highest point is where the slope is at its highest angle.

Correct temperature sensor placement is crucial to the performance and maintenance of your heater. If the sensor is placed too high or too low, your heater's internal safety switch will engage and shut off the heater before the 60 minute preheat time is finished, and your sauna may not come to temp. Incorrect temp sensor placement can also negatively affect the lifespan of your heater coils.

**If you have any questions about temp sensor placement, please contact Redwood Outdoors Customer Support for assistance.*

Virta Heater Temperature Sensor Recommended Placement

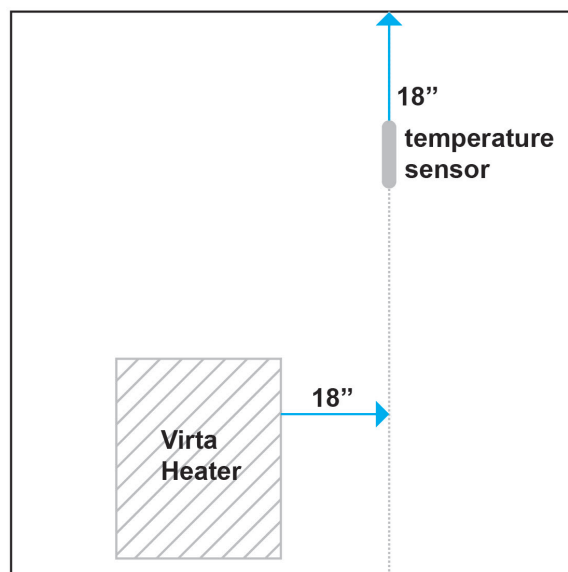

Complete heater manuals are available here



Roof Assembly

Step 23: Install the Roof

Place the roof pieces on top of the sauna.

The **roof pieces are not symmetrical**. You must position them so that the fixing strip under the roof board aligns with the cut on the sauna body.

When placed correctly, the boards should be touching the purlin at one end and beams #17/#18 at the other end.

Bring the boards together so that they are touching in the middle and there are no gaps at the center.

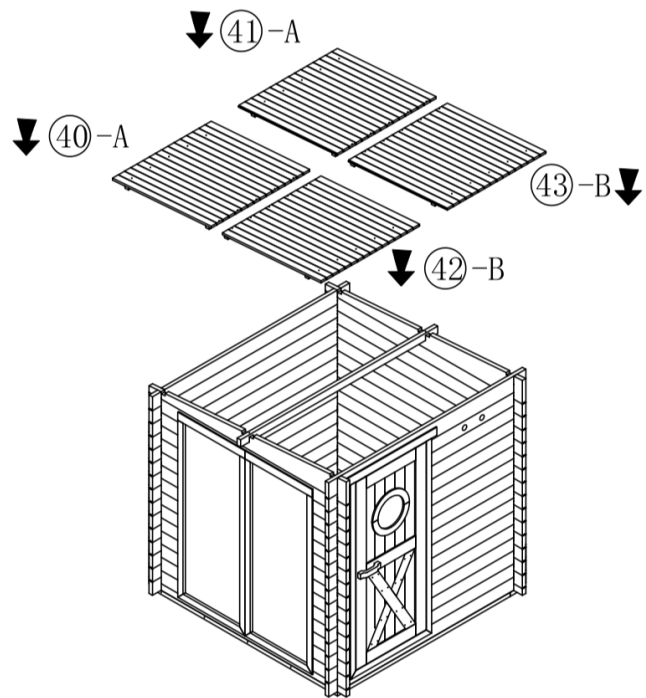
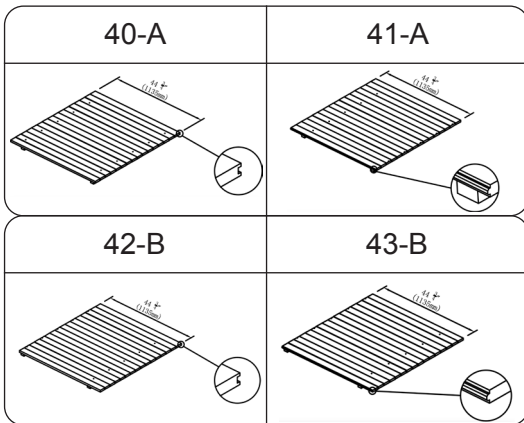



Roof Assembly

Step 24: Install the Roof Frame

Fasten the roof frame onto the front, back, and sides.

The flat piece will wrap under the sauna roof and the top of the frame should be flush with the top of the roof boards.

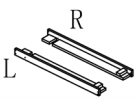
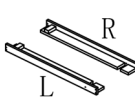
There is a cut in the flat piece to allow it to fit around the front/back wall boards.

36-B	37-B
	
39-A	D
	

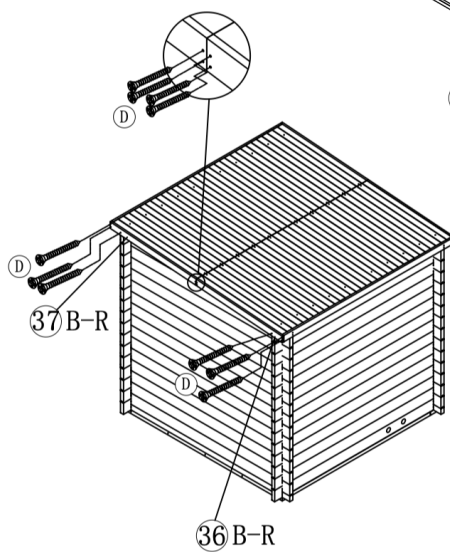
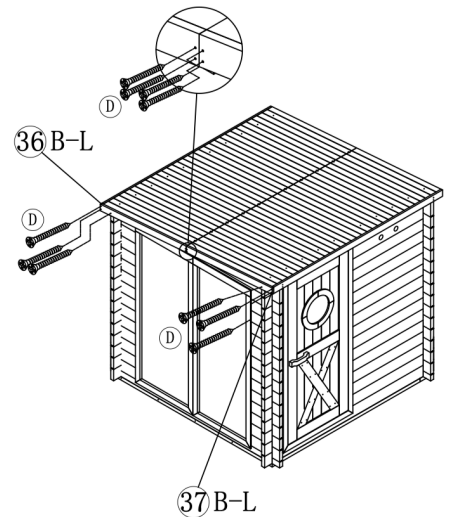
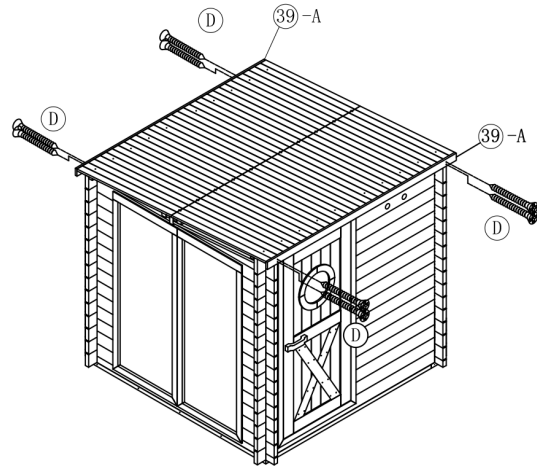

Roof Assembly

Step 25: Fasten the Roof

Once the frame is completed, fasten the roof board to the sauna body and purlin.

You do not need to fasten every board. Fasten every 3rd or 4th board at either edge.

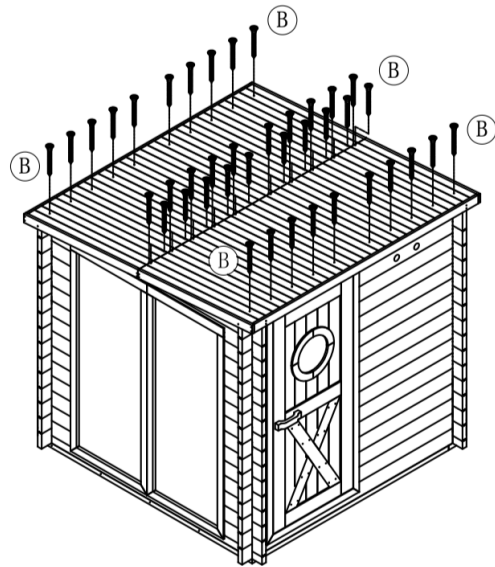
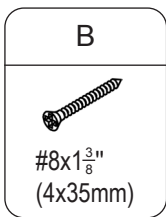

Step 26a: Install the Fixing Strips

Place the fixing strips at the front and back of the sauna to fix the beams in place. The fixing strips come in two half pieces, make sure you use both the top and bottom strip. Place the top strip as high up on the wall as possible.

At the front of the sauna (where the picture windows are), the fixing strips are installed on the **inside corner** of the front wall. #56 strips are used at the high end of the sauna, #55 strips are used at the low end of the sauna.

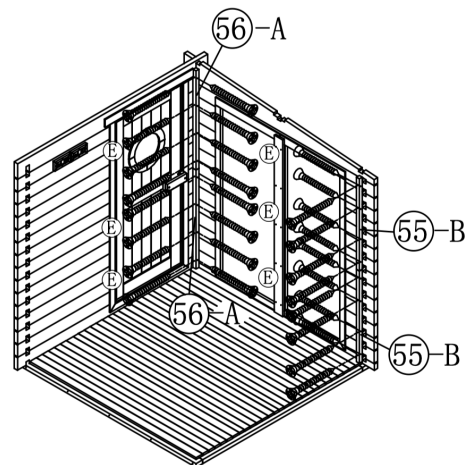
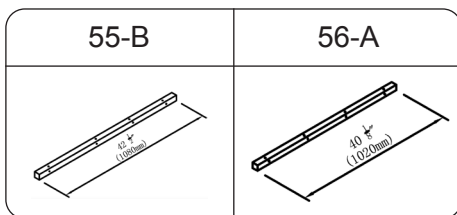

Bird's Eye View

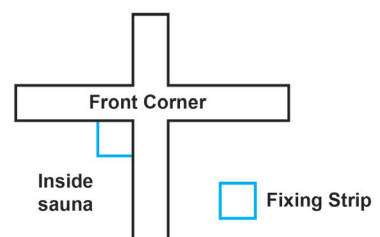



Exterior Finishing

Step 26b: Install the Fixing Strips

Place the fixing strips at the front and back of the sauna to fix the beams in place. The fixing strips come in two half pieces, make sure you use both the top and bottom strip. Place the top strip as high up on the wall as possible.

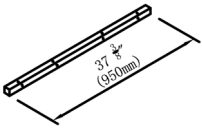
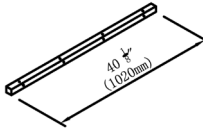
At the back of the sauna, the strips cannot be placed inside due to the benches. At the back, place one strip in **each of the 3 exposed corners**. #56 strips are used at the high end of the sauna, #55 strips are used at the low end of the sauna.

55-B	56-A	E
		
		#8x2" (4x50mm)

Bird's Eye View

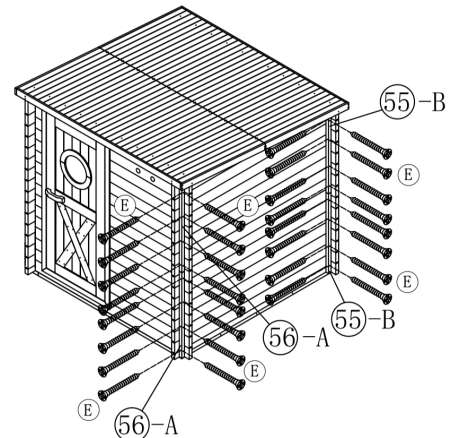
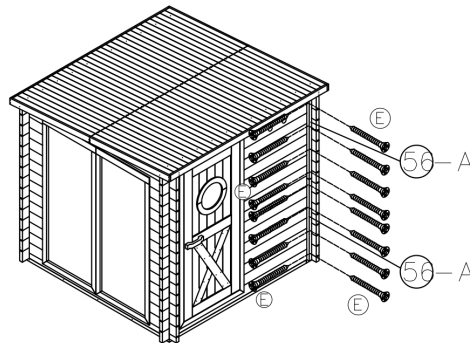
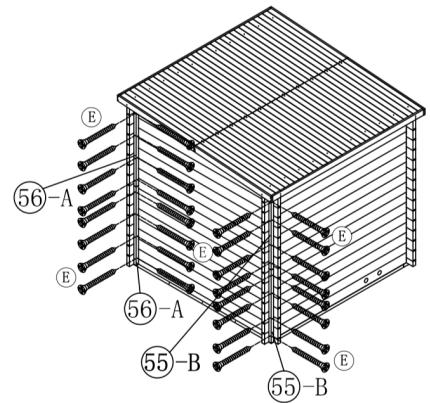
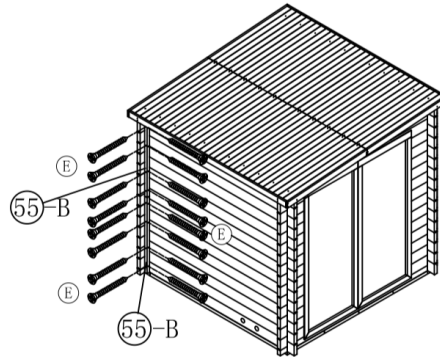
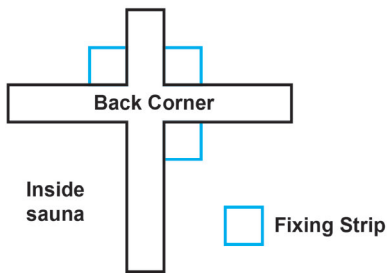

Shingle Assembly

Step 27: Place Roofing Underlay

Spread the underlay evenly across the top of the sauna. The edge of the underlay should line up with the edge of the roof. Cut away any excess underlay that sticks out beyond the roof edge.

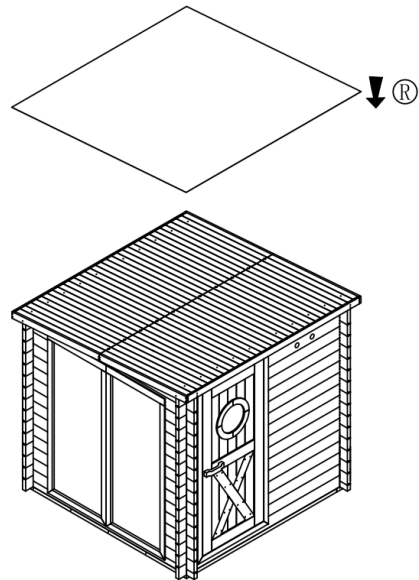
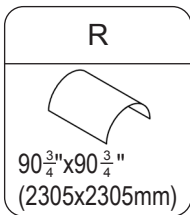



Shingle Assembly

Step 28a: Install the Shingle Rolls

Three rolls of asphalt shingles are provided. Remove the plastic back and then roll across your roof. The edges of each roll should overlap so that water can flow off the sauna without leaking in at the seams. Place the lowest roll first, and then the middle, then the upper.

Fasten the shingles to the roof frame using roofing nails. Note that roofing nails are not provided and should be sourced locally. If you are unable to source roofing nails, the A screws/washers provided with the kit can be used.

A	Q
	
#8x $\frac{3}{4}$ " (4x20mm)	93"x39 $\frac{3}{8}$ " (2360x1000mm)

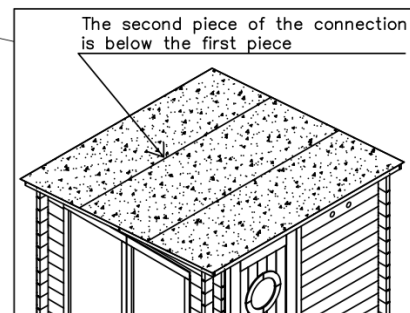
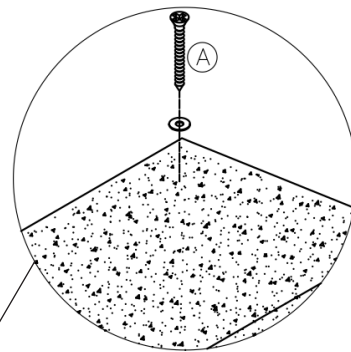
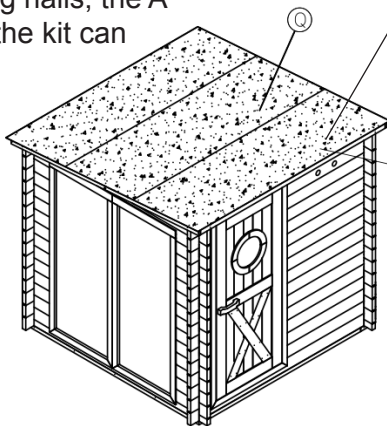

Shingle Assembly

Step 28b: Install the Shingle Rolls

The shingles should extend past the edge of your roof frame by $1\frac{1}{4}$ ". If the shingles are bent at a 90-degree around the corner of the roof frame, the shingle sheet may crack.

You may need to cut some excess off your shingle rolls at the edges to achieve this overhang.



View From Under the Shingles

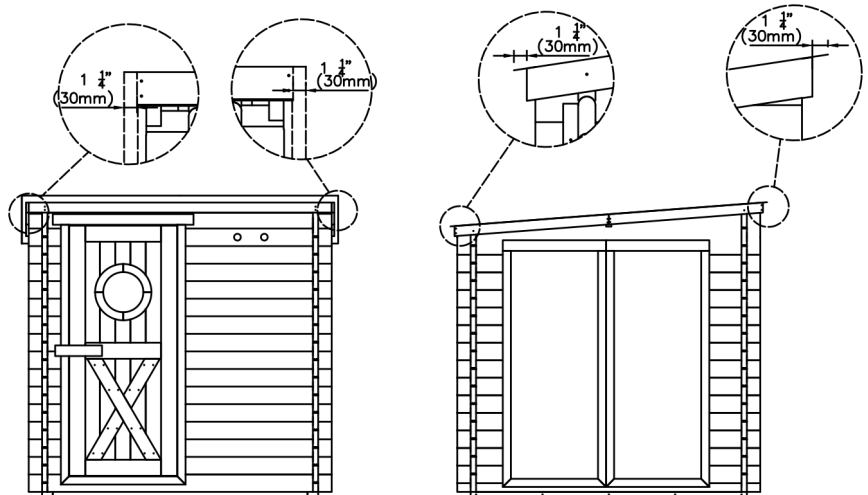

Shingle Assembly

Step 29: Install Drip Edge and Gutters (Optional)

To avoid water running onto the sauna walls, we recommend installing a drip edge and gutter system on the sides of the sauna roof.

This is not essential but will help keep your sauna dry and improve the effectiveness of your roofing. Drip edges and gutters are not provided because the sheet metal is easily bent/damaged during shipping but can be sourced locally.

If you will be installing a gutter system, this should be installed before you install the shingles (described in the previous page). An example drawing of how a gutter system is installed is shown below. If you decide to install gutters on your sauna, speak to your local hardware store or a building professional for advice on how to install them and what materials to buy.

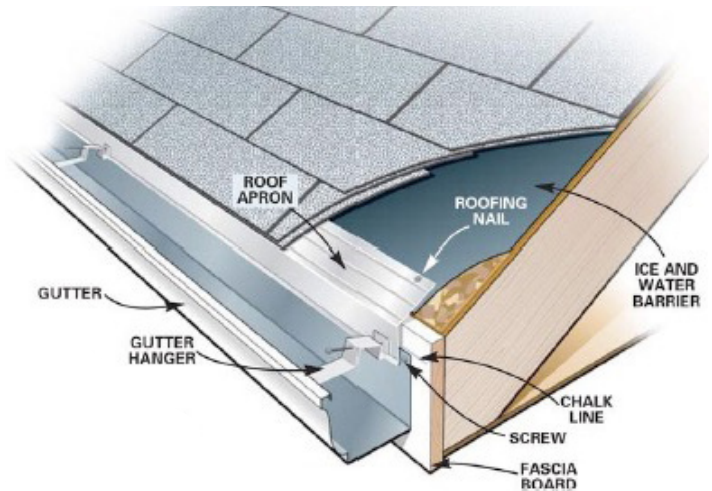

Interior Finishing

Step 30: Install the Light Fixture

A light fixture is provided with your sauna.

The light may be installed anywhere inside or outside of the sauna, as long as it is at least 4ft away from the heater and not installed directly above the heater.

The light fixture must be installed by a licensed electrician. Wiring for the light fixture is not provided and will need to be sourced locally.

The light must be wired to a separate **120v** line.

If you have a wifi-enabled heater, the light can be wired into the wifi kit's power box and will be controlled by the included control panel or through your mobile app. More information on this will be available in your heater's manual.

If your heater is not wifi-enabled, your electrician will need to supply a separate switch for the light as well.

Your electrician should determine the best way for the wiring to enter the sauna based on your site conditions and fixture placement. Consult with your electrician about how best to hide the wiring for the light.

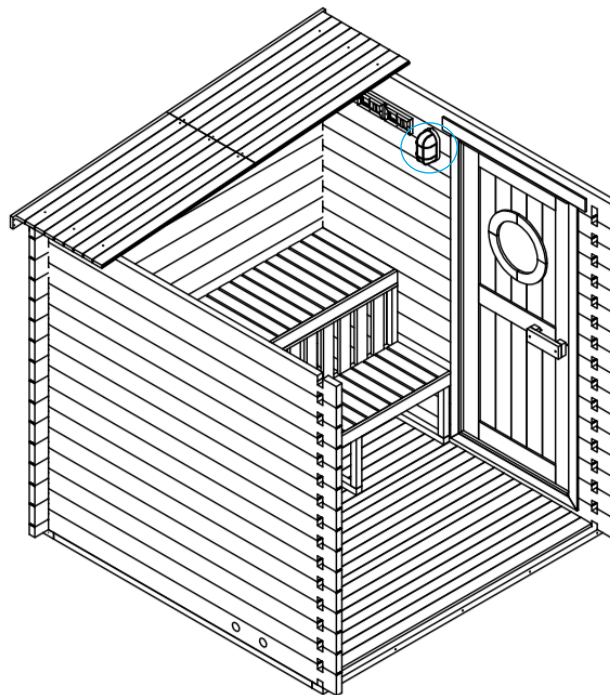

Maintenance

Maintaining Your Sauna After Installation

• Exterior Wood Treatment

Your sauna is designed for outdoor use, and the wood we use is naturally resistant to the elements. Nonetheless, over time your sauna will naturally weather, and the color of the wood will start to turn gray, especially in sunny areas. If you'd prefer to preserve the original exterior color of your sauna or even change the color completely, we recommend treating the **exterior only** with a water-based stain-and-seal. A stain-and-seal treatment will add extra protection against mildew as well. **Please note it is important that the inside of the sauna remains untreated to prevent fumes.**

If you would like to treat the interior of your sauna, Redwood Outdoors carries Supi Sauna Wax by Tikkurila. Supi Sauna Wax can be applied safely to wood inside the sauna room and provides long-lasting protection to keep your sauna looking its best.

• Roofing and Waterproofing

Without a roof installed, it is normal to experience water leaking through the roof boards. The interlocking staves do not form a watertight seal. We recommend installing our asphalt roof shingles, or sourcing your own roofing materials locally. Some customers have installed metal roofs or cedar shingles which work.

It's normal for some water to seep into your sauna, especially on windy days if rain is blowing onto the side walls of your sauna. This will not harm your sauna or diminish its lifespan. After a heavy rainfall, we recommend you run the heater for a 1-hour cycle to dry out the room. Running the heater a few times a week during the wetter months will help prevent mold or mildew from developing.

• Interior Maintenance and Cleaning

Treating your benches with paraffin oil will reduce the amount of sweat and dirt absorbed into the wood. We recommend treating new benches before using them; repeat the treatment once or twice a year after cleaning the sauna. Paraffin oil is colorless and odorless, and it will give the wood a slightly darker 'wet' look after it's applied. Be sure to **only use sauna-grade paraffin oil**, like Harvia Paraffin Oil, to prevent fumes. Paraffin lamp oil should not be used under any circumstances. Wood surfaces must be completely dry before applying an oil treatment.

Another option to protect and enhance the interior of your sauna is Supi Sauna Wax, which can be used on all surfaces inside the sauna, including benches, walls, floors, and ceilings. The wax absorbs into the wood, creating a silky matte finish that repels moisture and preserves the wood's natural look. Supi Sauna Wax is available in clear, white and black. Supi Sauna Wax is made in Finland by Tikkurila.

Under normal conditions, washing the interior of the sauna every 3 to 4 months will maintain cleanliness. We recommend using Harvia Sauna Cleanser or another suitable cleaning solution for wood. Refrain from using ammonia or harsh chemicals.

Clean the wood with a sponge or soft bristle brush and your cleaning solution. Always brush with the grain of the wood. If dirt is embedded in the benches, you can sand them down lightly. Rinse the sauna thoroughly with water to remove all the cleaning product. Run the heater for 1 to 2 hours to dry out the room and then leave the door open to air out the sauna.

Maintenance

For stainless steel surfaces on your heater, we recommend Harvia Sauna Heater Cleanser which removes limescale stains.

Re-stack your sauna rocks every 6 months as the rocks will break down over time in high heat. Ensure that the rocks do not shift and cause the heater coils to bend into one another. We recommend replacing your sauna rocks completely every 12-18 months.

After you have finished each sauna session, we recommend running the heater for an additional 60 minute cycle with the door closed. This will dehumidify the room and dry out the wood. If you are using your sauna regularly (i.e., multiple times a week) and drying out the room after each session, this should largely prevent mold formation.

If you are not using your sauna regularly, run a dehumidifier and/or fan inside the sauna to keep air circulating (and empty the dehumidifier water tank regularly). Also place desiccants (e.g., a commercial desiccant such as Damp-Rid or non-commercial desiccant such as charcoal briquettes/kitty litter) on dishes and place them around the inside of the sauna.

• Preventing and Treating Mold

The key to preventing mold from forming is to ensure the inside of the sauna is frequently dried out. Mold can develop as a result of moisture getting trapped inside the sauna over prolonged periods of exposure to sweat and steam or precipitation.

If you see mold on the inside or outside of your sauna, this should be treated early before it has time to grow and take hold. Clean the affected area with household white vinegar and gently scrub the area with a soft scrub brush and soapy water.

If you are unable to remove the mold with vinegar and soap, try stronger cleaning agents such as 30 Seconds Outdoor Cleaner or Behr All-in-One Wood Cleaner. Rinse the sauna thoroughly with water to remove the cleaning solution. Run the heater for 1 to 2 hours to dry the room. Any rags or scrub brushes that come into contact with the mold must be disposed of. **Proper protective equipment (goggles, mask, gloves, etc.) must be worn when removing mold.**

• Instructions for First Time Use

Before placing the rocks in your heater, wash them off and dry them to remove any dust. Once they are dry, add the rocks to your heater. Make sure your rocks are not stacked too tightly to allow for appropriate air flow.

To prepare your heater for your first sauna session, turn your heater on to its highest heat setting for an hour. This will burn off the protective oil on the heater coils that may cause a mildly unpleasant smell. The sauna should not have anyone bathing in it during this cycle. Never run your heater without the rocks. After the initial 1 hour cycle, leave the door open and let the sauna air out for several hours.

Now your sauna is ready to use!

Warranty

- **Warranty**

Our saunas and sauna heaters come with a 1-year limited warranty. Please refer to <https://www.redwoodoutdoors.com/warranty> for detailed warranty information on our products.

- **Serial Number**

Each of our saunas is fitted with a unique serial number. This number is used to verify your sauna's authenticity as well as streamline service requests.

2503C1S0001

Example Serial Number Plate

The plate is attached to one of your sauna's base pieces. You can position it on the side opposite to your sauna's door, so it is not visible during daily use.

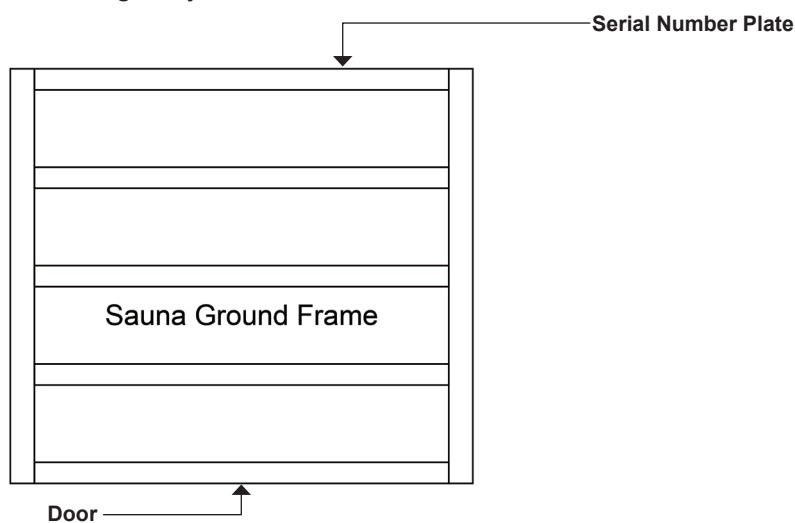

Please make a note of your sauna's serial number. If you require assistance, **please include the serial number in your email to Redwood Outdoors' customer support team**. This will allow our team to quickly access your production and shipping details so we can resolve any issues promptly.

User Guide

How to Take a Traditional Finnish Sauna

- Traditional sauna bathing is done in 'rounds' or intervals. A round involves heating the body up and then cooling it down. A typical round consists of 10-15 minutes in the sauna followed by a cool down period of approximately 5 minutes.
- Preheat the sauna to your desired temperature (traditional Finnish saunas run between 160°F and 185°F). Preheating typically takes 45 minutes to an hour. If the ambient temp outside is below 20°F, preheating may take longer than one hour. Digital sauna heaters can be started remotely via Wi-Fi. Manual control sauna heaters can be set on a delay timer to start at a predetermined time up to 8 hours in the future.
- All residential sauna heaters have a maximum independent run time of 1 hour for safety reasons, but they can be restarted again as many times as desired. When you enter the sauna for your first round, begin by resetting the heater to the full 1 hour.
- The first sauna round is typically enjoyed dry, which means no water is added to the rocks. Heat stacks in a sauna, so it's normal that the floor will be much cooler than at your head. If you find your head gets too hot, you can wear a sauna hat, which will help keep your head cooler and allow you to feel more of the heat sensation on your body.
- After 10-15 minutes, exit the sauna and begin your cool down phase. If you have an outdoor shower or cold plunge tub, this can be used during your cool down and provides for a much more rapid and effective cool down phase. The goal is to bring your body temperature back down in preparation for the next hot phase.
- The 2nd and 3rd sauna rounds are typically enjoyed with added humidity, which increases the sensation of heat. Water can be gently ladled on to the rocks to create steam or 'löyly'.
- You may add aromatherapy oils to your water bucket to create a scented steam. The classic scents used in Finland are birch, pine and eucalyptus. All aromatherapy oils are formulated differently, so make sure yours does not leave any residue on the rocks.
- When pouring water on the rocks, do so slowly and only when the sauna is at full temperature. The water should evaporate instantly when it hits the rocks. If you notice water coming out the bottom of the heater it means you are pouring too fast or too much. If you like to use a lot of water in the sauna, it is recommended to buy a sauna fountain. These stone fountains sit amongst the rocks and help create steam.
- A typical sauna session is 2 or 3 rounds. Do not skip the cool down phase on your final round. A sauna session ends with a cool down, after which you can take a warm shower.
- It is important to drink water during a sauna session. You should aim to drink at least 24 ounces of water during a session.
- Excessive heat exposure can be harmful to a person's health. People with certain health conditions should consult their physicians before using the sauna.

***SAUNA BATHING IS NOT RECOMMENDED FOR CHILDREN UNDER 14.
CHILDREN MUST BE SUPERVISED BY ADULTS.***

User Guide

How to Ventilate Your Sauna

• Why Ventilation is Important

Your sauna needs to breathe just like you do. Taking deep, refreshing breaths while you're using the sauna is key to a great experience. Proper ventilation ensures you're getting fresh, oxygen-rich air with every breath.

The flow of air through your sauna helps to distribute hot air around the sauna room, creating a more even temperature distribution.

• How Your Sauna is Ventilated

Your sauna is designed with natural updraft ventilation.

Cool air comes in through the intake vents below the heater and is warmed. With the natural updraft ventilation hot air flows out of the exhaust vents, creating a vacuum that pulls in fresh air through the intake vents completing the convective loop. Warm air spreads out through the sauna, allowing bathers to enjoy hotter temps.

Without a ventilation system, the warm air rises and stacks at the top of the sauna, leaving the benches and floor feeling significantly cooler.

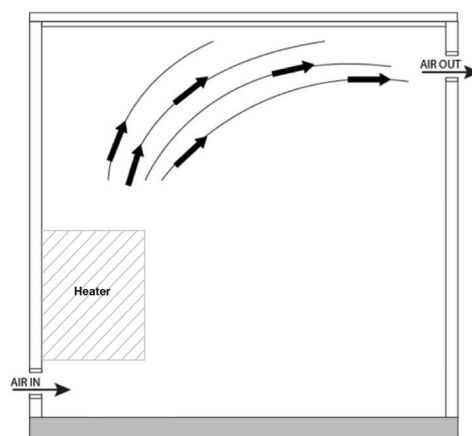

• How To Use Your Sauna's Ventilation System

We recommend always keeping the two intake vents open, as this cools your heater preventing it from shutting off pre-maturely.

While your sauna is heating, the two exhaust vents should be closed.

Open the exhaust vents when you enter the sauna to create air circulation.

If you leave the sauna but are coming back for another round. Close the exhaust vents.

If you leave the sauna and have finished your session. Leave the exhaust vents open to help dry the sauna out.

Ventilation is an art and a science. The right way to use the sauna's ventilation will depend on your location, weather conditions, and your personal preferences.

The suggestions above are general guidelines. We encourage you to try different approaches and find the best combination for you. For example, you may have a better experience when you keep one intake vent closed during heat-up and only open one vent while inside.

Using a manual or electric fan can greatly improve the temperature distribution inside your sauna. We recommend using a fan if you find you have large temperature differences inside your sauna.

User Guide

Important Note About Heat-Up Times

During colder winter months, your sauna will take longer to reach the desired temperature. This is **normal** and is due to external conditions.

Several factors contribute to slower heat-up times in winter:

- **Ambient Temperature:** When your sauna starts heating from a low outdoor temperature—especially near or below freezing—the heater must work harder and longer to raise the room's temperature.
- **Cold Rocks:** It takes longer to heat the rocks in the heater that are at the same low temperature as the air inside your sauna. The rocks must heat up first before the room can start heating.
- **Heat Loss Through Surfaces:** The sauna's walls, floor, and roof are much colder. These surfaces absorb heat and lose heat to the environment as the sauna warms up, reducing the speed the room's temperature rises.
- **Wind and Airflow:** Outdoor air movement can increase heat loss, especially if the sauna is not in a sheltered location.
- **Humidity and Snow:** Moisture in the air, snow on the roof, or frost on the panels can draw heat away from the interior as the heater operates.

To improve heat-up times in winter:

- Allow extra time for the sauna to preheat before use.
- Make sure the door is kept closed to minimize heat loss.
- Clear snow or frost from the exterior before use if possible.
- Consider installing a windbreak or shelter if your sauna is in a particularly exposed area.

Please note that most sauna heaters have an automatic safety shutoff after 60 minutes. To continue heating after 60 minutes have passed, you must restart the heater.

IMPORTANT NOTICE

YOU ARE SOLELY RESPONSIBLE FOR: (A) ENSURING COMPLIANCE WITH ALL APPLICABLE BUILDING CODES, ZONING, ORDINANCES, BUSINESS DISTRICT OR ASSOCIATION RULES, COVENANTS, CONDITIONS, AND RESTRICTIONS, LEASE OBLIGATIONS, LANDLORD OR OWNER APPROVALS OR REQUIREMENTS RELATED TO ANY PRODUCTS YOUR PURCHASE; AND (B) OBTAINING ANY PERMITS OR AUTHORIZATIONS NECESSARY FOR INSTALLATION AND/OR USE OF SUCH PRODUCTS, INCLUDING ANY PAYMENT OF ANY FEES OR OTHER CHARGES FOR PERMITS OR AUTHORIZATIONS (COLLECTIVELY, "LEGAL REQUIREMENTS"). THIS INSTALLATION MANUAL IS PROVIDED SOLELY AS A COURTESY TO YOU AND DOES NOT CONSTITUTE ANY WARRANTY BY REDWOOD OUTDOORS TO YOU REGARDING THE PLACEMENT OR INSTALLATION OF THE PRODUCT. THIS MANUAL IS NECESSARILY GENERAL IN NATURE AND MAY NOT TAKE INTO CONSIDERATION ALL OF THE CONDITIONS AND CIRCUMSTANCES OF YOUR PROJECT. YOU ARE SOLELY RESPONSIBLE FOR DETERMINING WHETHER THE PLACEMENT AND INSTALLATION OF THE PRODUCT IS APPROPRIATE AND IN COMPLIANCE WITH ALL LEGAL REQUIREMENTS. YOU SHOULD CONSULT QUALIFIED CONSTRUCTION, ELECTRICAL, ENGINEERING OR OTHER SERVICE PROFESSIONALS IF YOU HAVE QUESTIONS ABOUT THE PROPER INSTALLATION OF THE PRODUCT. REDWOOD OUTDOORS AND ITS SUPPLIERS WILL NOT BE LIABLE TO YOU FOR ANY CLAIMS OR DAMAGES ARISING FROM YOUR INSTALLATION, MAINTENANCE, OR REPAIR OF ANY PRODUCT.



REDWOOD
OUTDOORS

View this manual online
here



View the assembly video
here



Contact Info

Phone: 1-800-567-8036
Email: support@redwoodoutdoors.com
Website: www.redwoodoutdoors.com

Version

Date: Jan 15, 2025
Version: 6.0