

ASSEMBLY INSTRUCTIONS

DINING CHAIR

ASSEMBLY

2-Person

20 MINUTES

Tools Required:  

REQUIREMENTS

Assembly

Assembly Time
Per Stool (Approximate)

(Not Provided) Phillips Screwdriver

Thank you for purchasing our product!

Please refer and use this assembly instruction to assemble the product. Contact our customer service department in case there are any missing or damage parts or hardware. Replacement parts are normally shipped within 2 or 3 days.

We appreciate your business!

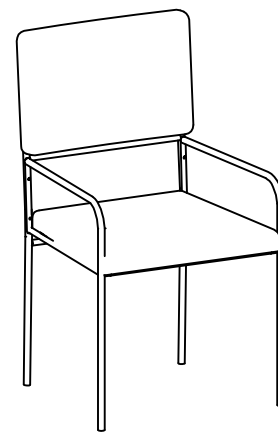

ASSEMBLY PREPARATION

1. Remove all packaging materials, staples and packing straps from the carton.
2. Refer to Parts List and Hardware List, and ensure parts and hardware are correct before assembly. Contact customer service for missing parts.
3. Place all wooden parts on a clean, flat and soft surface (e.g. carpet or rug) to prevent scratch and damage to parts.

SAFETY PRECAUTION:

1. KEEP ALL HARDWARE PARTS OUT OF REACH OF CHILDREN.
2. DISPOSE PLASTIC PACKAGING MATERIAL IMMEDIATELY TO AVOID ANY RISK OF SUFFOCATION TO CHILDREN AND ANIMALS.

TIPS FOR ASSEMBLY:

1. Allow ample room for assembly and in close proximity to where product will be placed.
2. Assemble the product on a surface that does not scratch or damage the exterior gloss and finish of the furniture.
3. Identify all of the parts, hardware and quantities required for each step.
4. During assembly, do not over-tighten any fittings as this may cause damage.
5. **DO NOT USE POWER TOOLS TO ASSEMBLE THIS PRODUCT.**
6. Always place the product on a flat, level surface.
7. Do not sit or stand on the partially assembled product; only use the product for which it is intended.







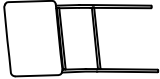
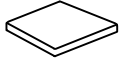

CARE AND MAINTENANCE

- Use a slightly damp cloth to clean the product. Do not use bleach or abrasive cleaning material.
- Check all the fittings periodically and re-tighten as necessary. Do not use the product if any of the parts is damaged or broken.
- Never allow any kind of liquid to remain on your furniture. Absorption can cause wood to warp or delaminate.
- Do not place hot items (e.g. hot drinks) directly onto the wood surface.
- Do not drag and/or pull the furniture.

This product is for indoor and household use only - not for commercial use.

ASSEMBLY INSTRUCTIONS

DINING CHAIR

A		Chair back	1PC	F		Cushion seat	1PC
B		Left Leg	1PC	G	 1/4 X 12MM	Bolt	20PCS
C		Right Leg	1PC	H		Screw	8PCS
D		Rear Stretcher	1PC	I		Allen wrench	1PC
E		Front Stretcher	1PC	J			

STEP 1

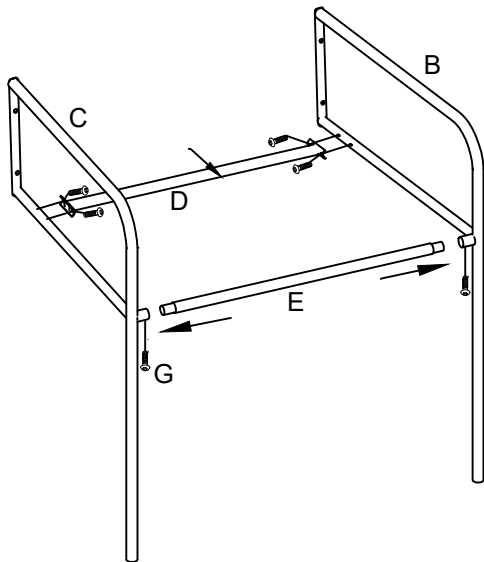

Use Rear Stretcher (D) and Front Stretcher (E) to connect Left & Right Leg (B & C) as shown and fasten with Bolt (G). Use Allen Wrench (I) to drive (G).

STEP 2

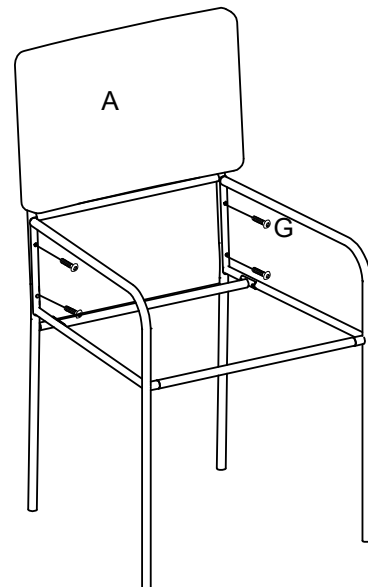

Attach Chair Back to Left & Right Leg assembly in STEP 1 as shown and fasten with Bolt (G). Use Allen Wrench (I) to drive (G).

STEP 3

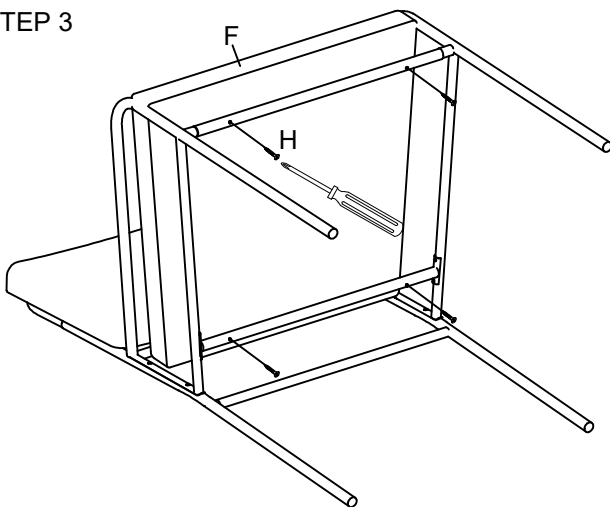

Lay assembly from STEP 2 on its back as shown. Fit Cushion Seat (F) squarely on Front & Back Stretcher and fasten with Screw (H).

STEP 4

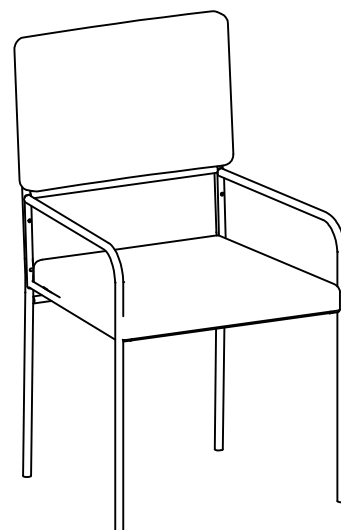

Set the chair right-side up. The assembly of the chair is complete.