

# Salon Cabinet

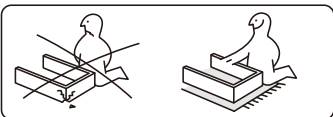

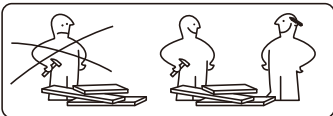

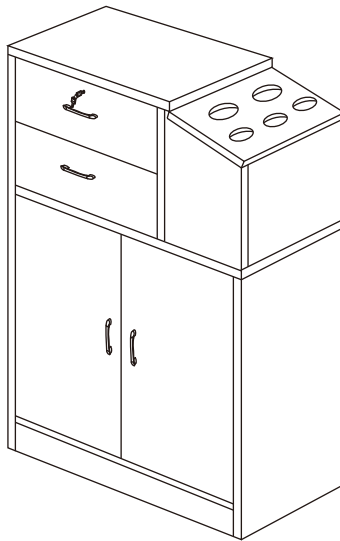







## ASSEMBLY INSTRUCTIONS

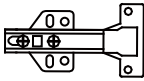

### **IMPORTANT!**

Do not tighten too hard: this can damage boards. Please just screw 30%-50% until all the screws have been screwed into the holes.

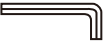

# Parts list

Letter	Components	Pieces	Letter	Components	Pieces
A		42	H		1
B	 Cams	42	J	 M3.5x20mm	4
C		16	K		2
D	 20mm	8	M		6
E		4	N	 M3.5x12mm	36
F	 40mm	8	S		4
G		1	V	 Cam covers	30

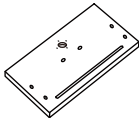
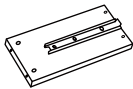
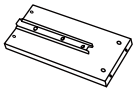
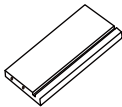
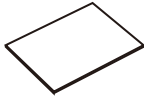
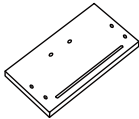
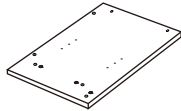
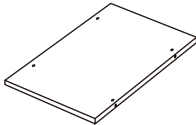
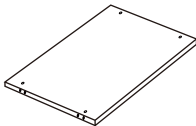
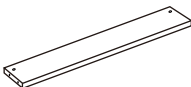
# Parts list

	394×152×16mm	1	①
	300×90×16mm	2	②
	300×90×16mm	2	③
	341×90×16mm	2	④
	351×294×3mm	2	⑤
	394×152×16mm	1	⑥
	658×418×16mm	1	⑦
	658×578×16mm	1	⑧
	578×400×16mm	1	⑨
	578×70×16mm	1	⑩

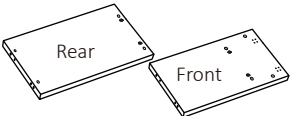
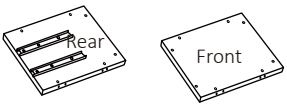
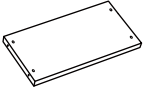
# Parts list

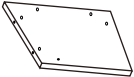
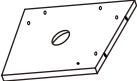
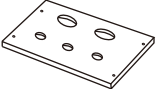
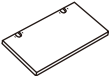
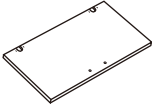
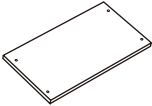
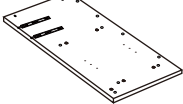
	595×418×16mm	1	⑪
	410×316×16mm	1	⑫
	398×310×16mm	1	⑬
	442×420×16mm	1	⑭
	292×180×16mm	1	⑮
	292×180×16mm	1	⑯
	418×219×16mm	1	⑰
	378×180×16mm	1	⑱
	568×286×16mm	2	⑲
	577×382×16mm	1	⑳
	984×418×16mm	1	㉑

# Assembly

**1**

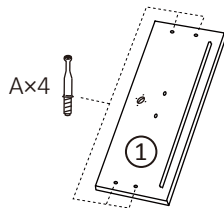
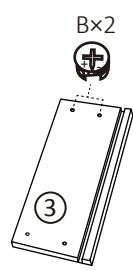
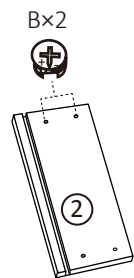
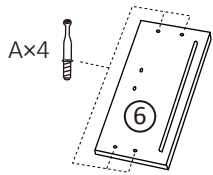
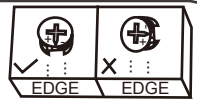

**2** x2

**3** x2

**2** x2

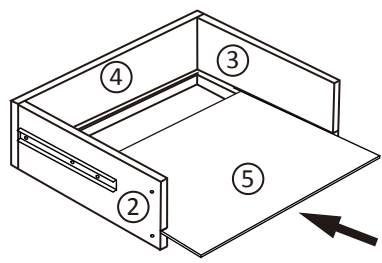
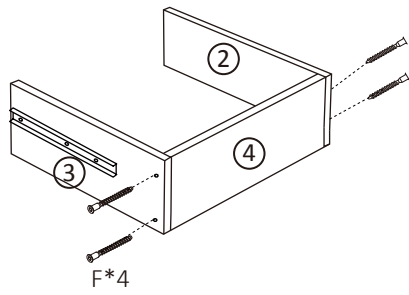

# Assembly

3

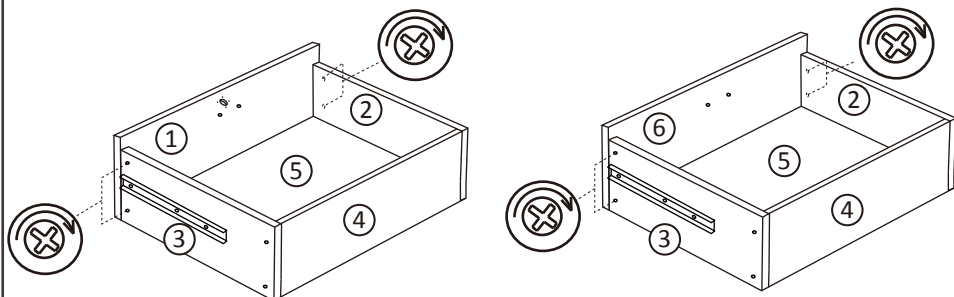

4 Separate the lock parts as below.

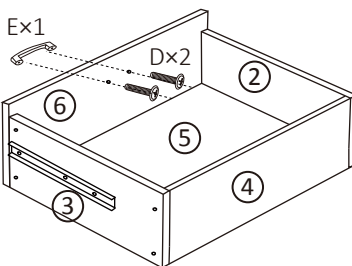
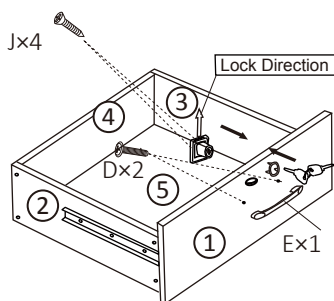

# Assembly

5

Bx4

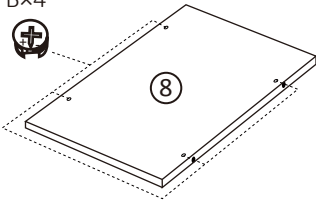

Bx2

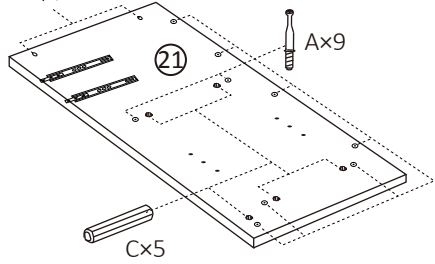

Bx4

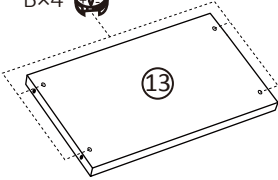

Bx2

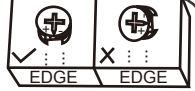
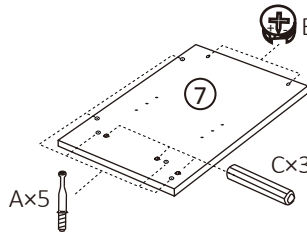

6

Bx4

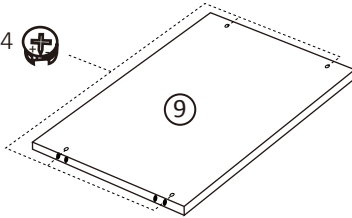

Bx5

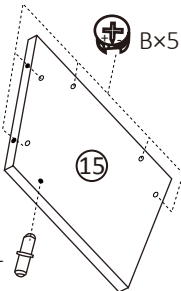

Bx5

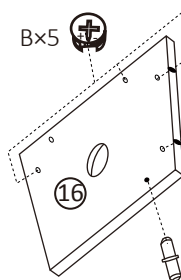

Kx1



Kx1



# Assembly

7

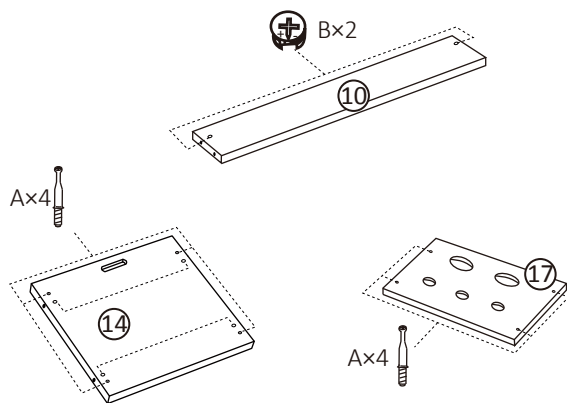

8

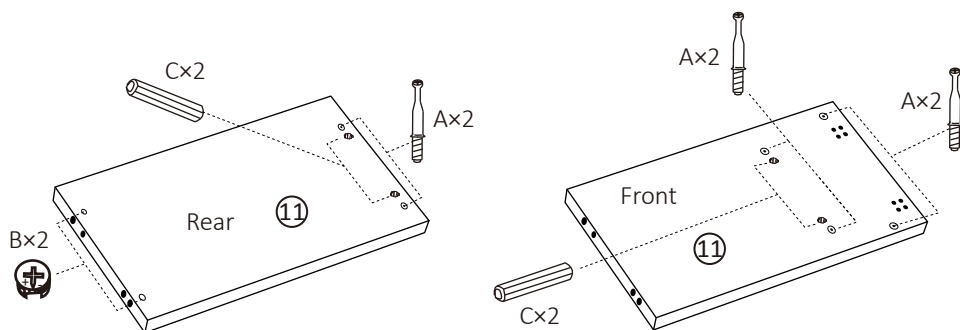

# Assembly

9

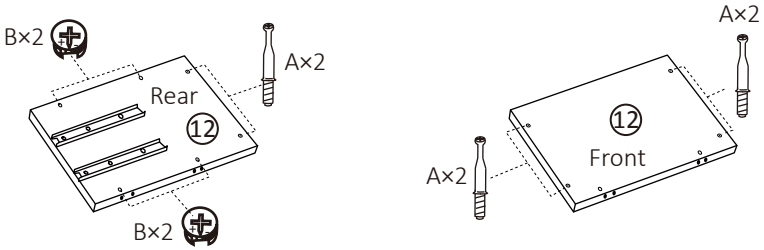

10

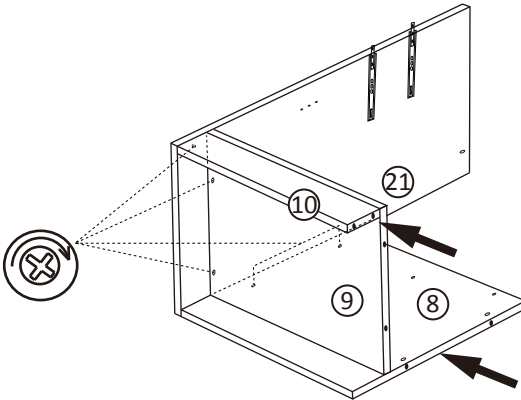

# Assembly

11

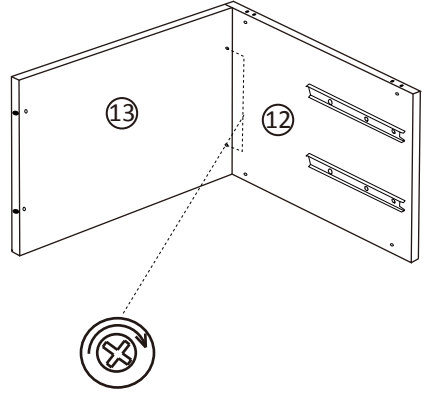
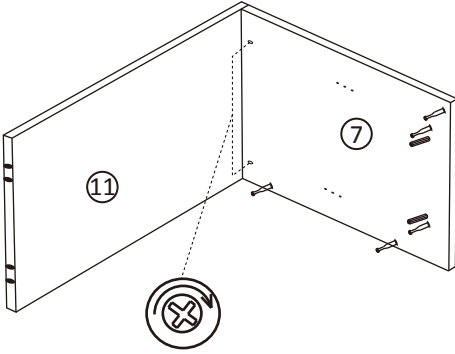

12

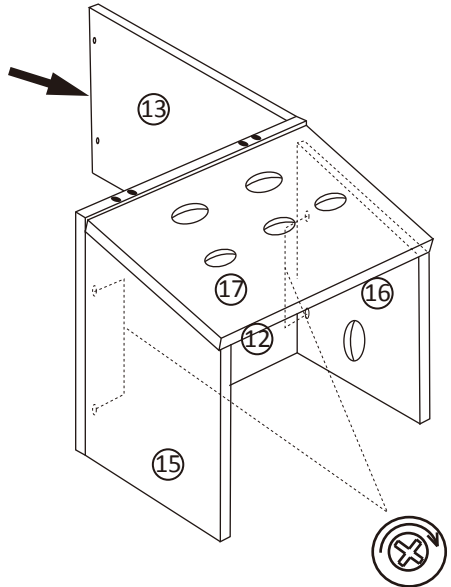
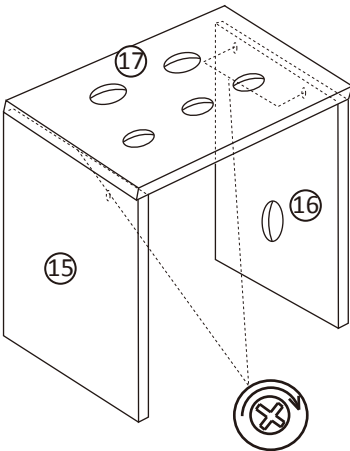

# Assembly

13

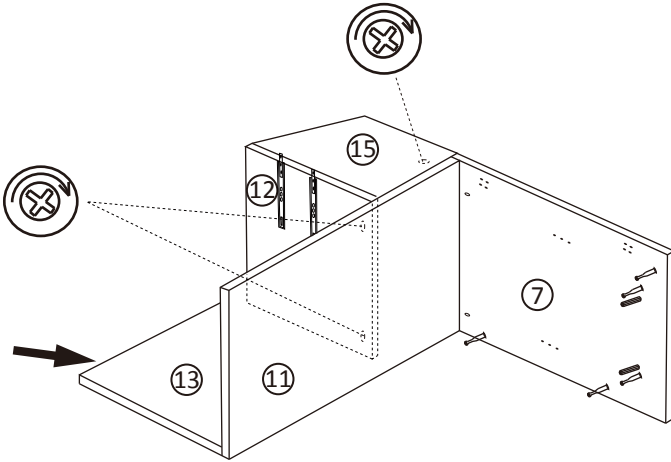

14

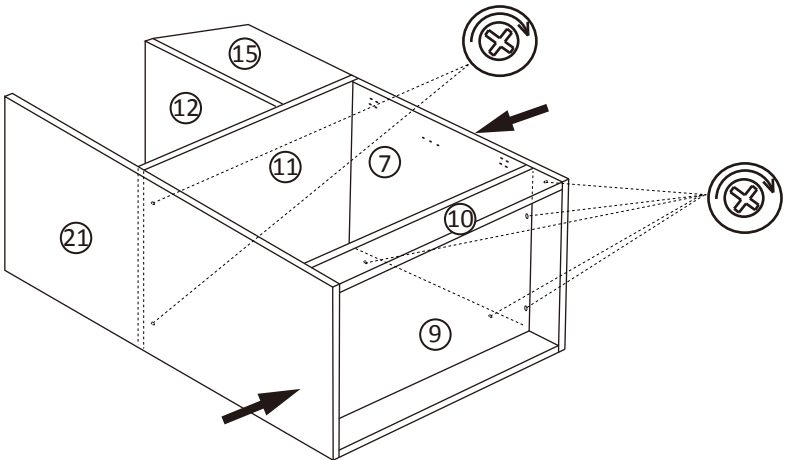

# Assembly

15

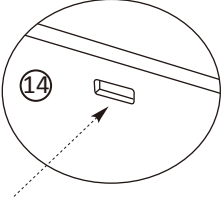

Please note the location of the lock slot on top panel 14 is facing out

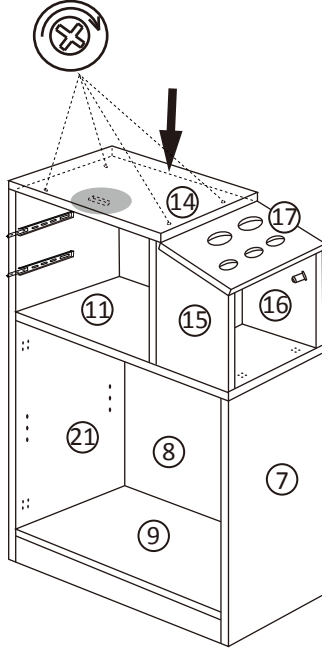

16

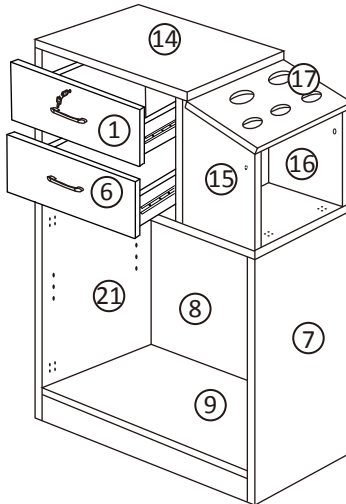

# Assembly

17

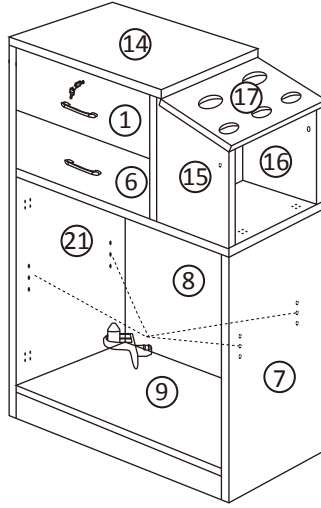
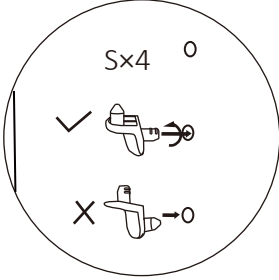

18

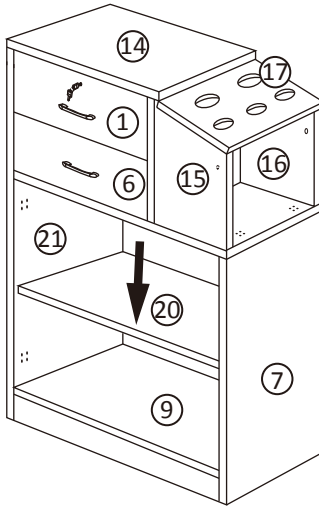

# Assembly

19

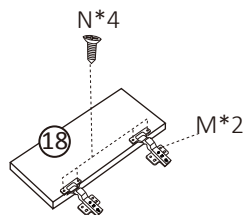
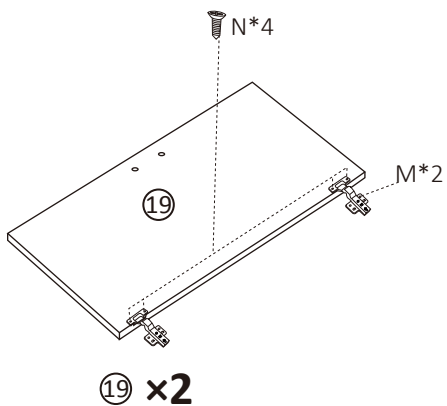

20

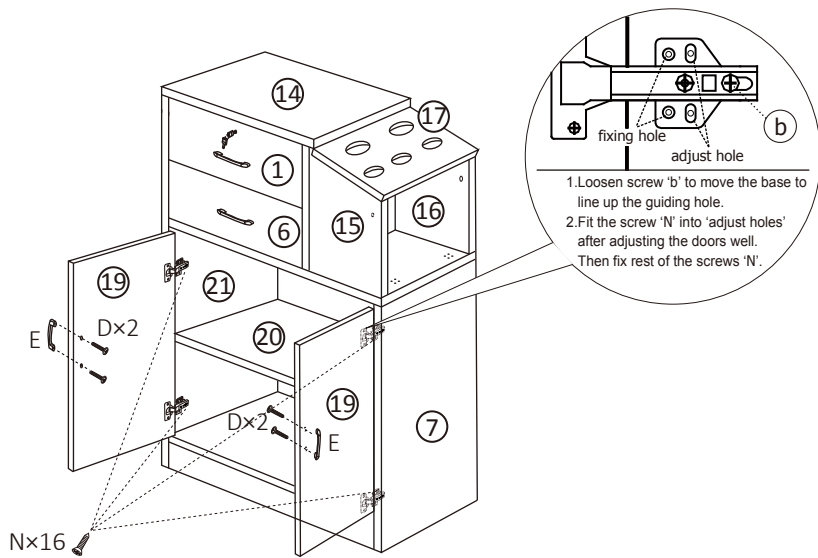

# Assembly

21

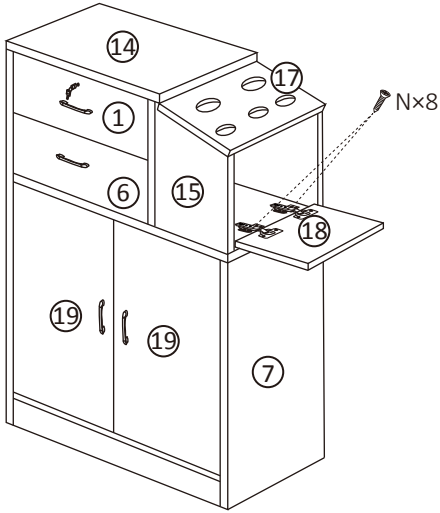

22 **Note:** please fit covers (V) onto visible/exposed cams and screws to complete assembly.

