

THKFBV156AK0BW
THKFBV156BK0BW
THKFBV156WH0BW
THKFBV157AK0BW
THKFBV157BK0BW
THKFBV157WH0BW
THKFBV158AK0BW
THKFBV158BK0BW
THKFBV158WH0BW

INSTALLATION INSTRUCTIONS

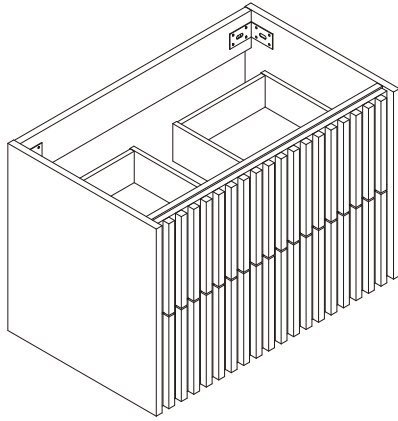





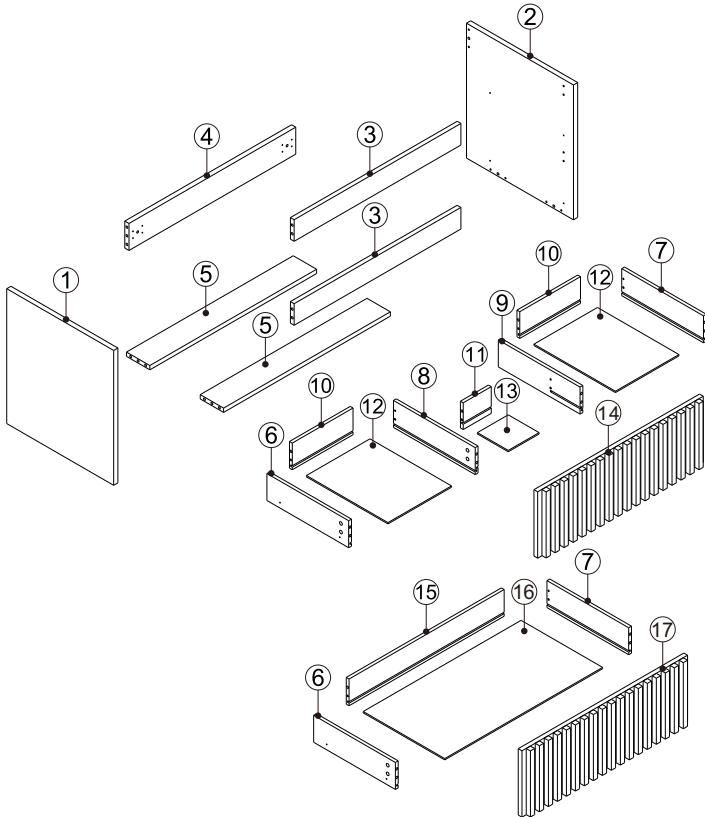





















*The vessel and faucet set is not included



ASSEMBLY DIAGRAM



PARTS LIST

PARTS LIST			HARDWARE LIST		
No.	Description	QTY	No.	Description	QTY
1		1	A	 Metal Dowel	40
2		1	B	 Wood Plug Ø8x30	6
3		2	C	 Wood Plug Ø6x30	8
4		1	D	 Ø15x11	20
5		2	E	 Ø12x10	20
6		2	F	 Screws M4x12	40
7		2	G	 Slider	4
8		1	H	 Bracket	2
9		1	I	 Cover	20
10		2	J	 Cover	20
11		1	K	 Screws For Fix On The Wall M5.5x60	2
12		2			
13		1			
14		1			
15		1			
16		1			
17		1			

CAUTION: Please confirm the parts list before installation

YOU MAY NEED (NOT SUPPLIED)

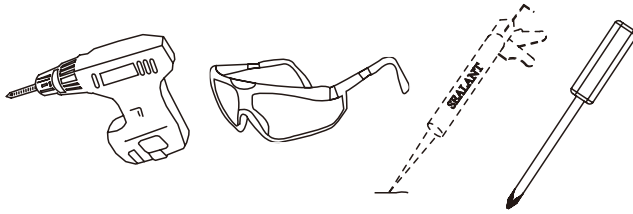

INSTALLATIONS

STEP 1

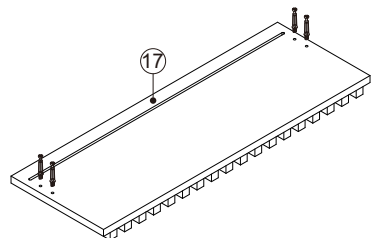
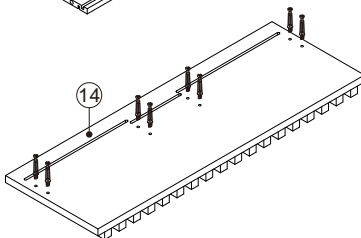
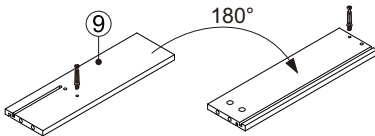
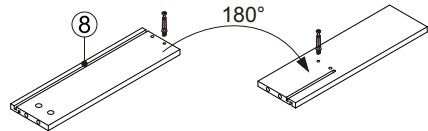
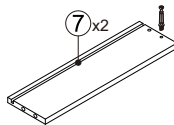
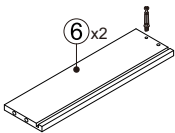
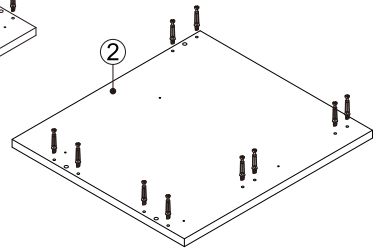
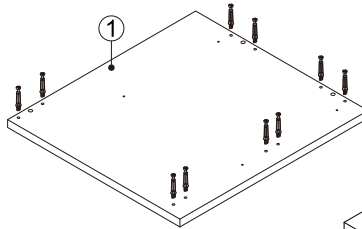
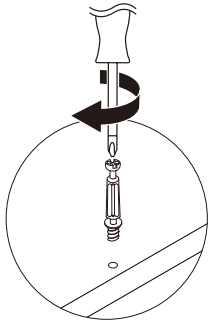

HARDWARE LIST	
A 	40PCS



- Insert the cam screw into the boards above.

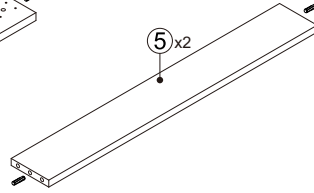
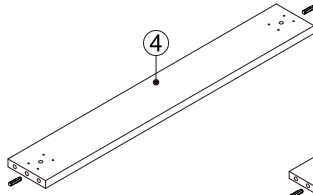
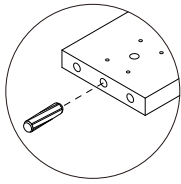

STEP 2

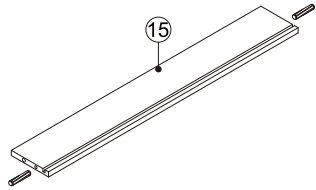
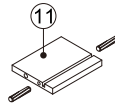
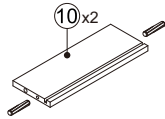
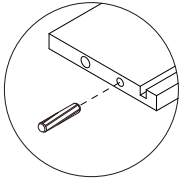

HARDWARE LIST			
B		6PCS	

STEP 3



HARDWARE LIST			
C		8PCS	

- Insert the wooden dowel pins into the boards.

STEP 4

HARDWARE LIST			
G		4PCS	
F		12PCS	

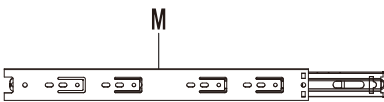
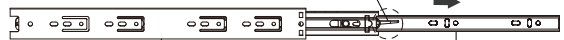
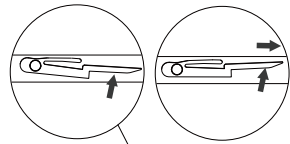

- Keep pressing here, then pull out to device the slide.

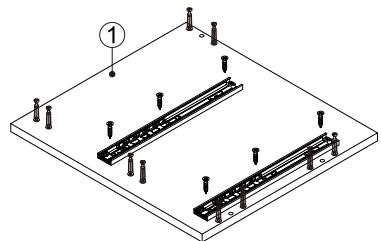
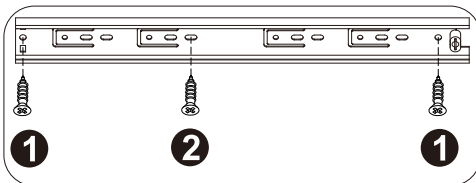

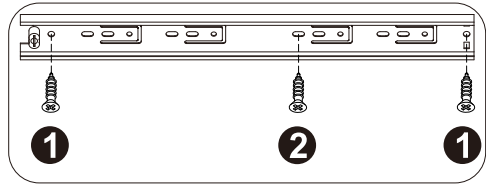
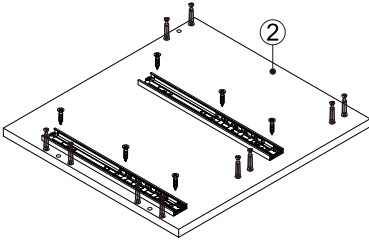

- Refer to the illustration, to fix the slide rails to the boards #1,#2 with screws.

STEP 5

HARDWARE LIST		
J		10PCS
D		10PCS

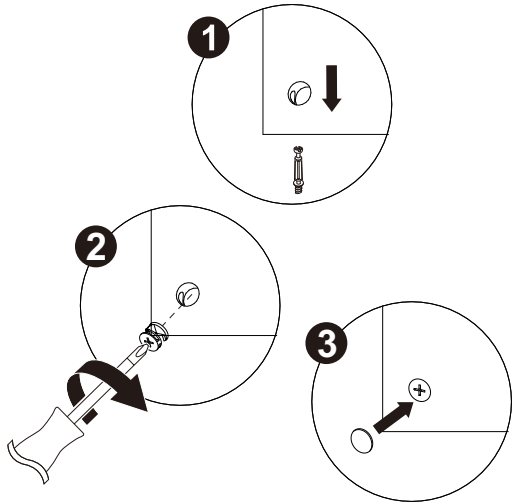
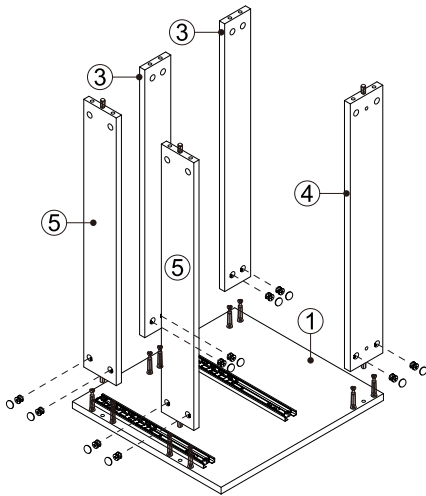
- Refer to the illustration, insert the boards #3,#4,#5 on the board #1. Then tighten the cam lock with the cover.

STEP 6

HARDWARE LIST		
J		10PCS
D		10PCS

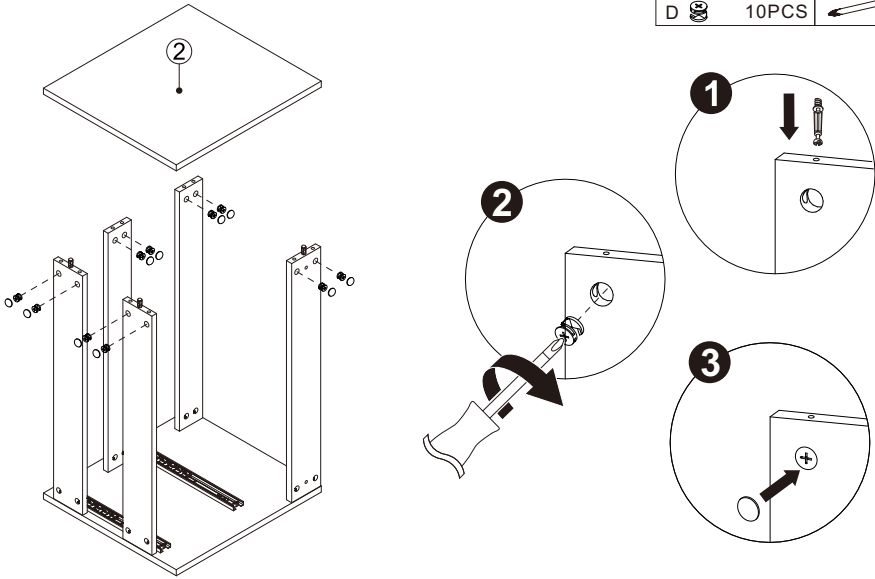

- Refer to the illustration, Install board #2 on the cabinet. Then tighten the cam lock with the cover.

STEP 7

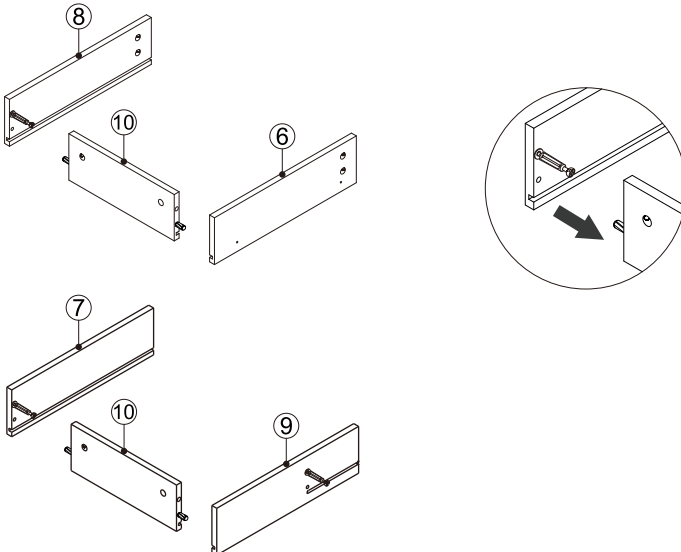

- Refer to the illustration, Connect the boards #6, #8, #10. Connect the boards #7, #9, #10.

STEP 8

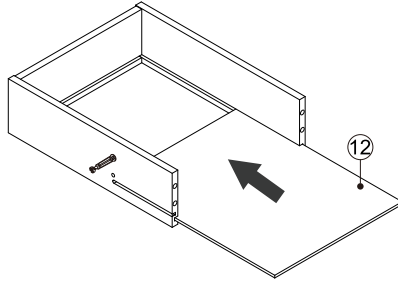
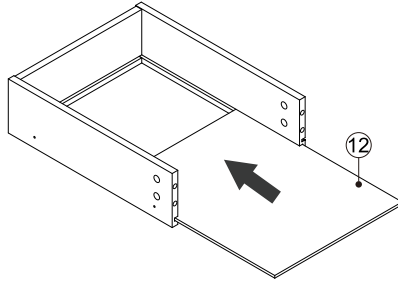

- Refer to the illustration, Insert the boards #12 into the finished board.

STEP 9

HARDWARE LIST			
E		4PCS	
I		4PCS	

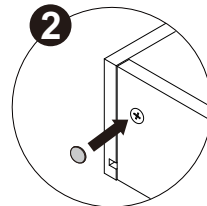
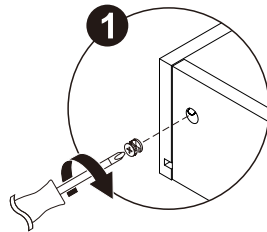
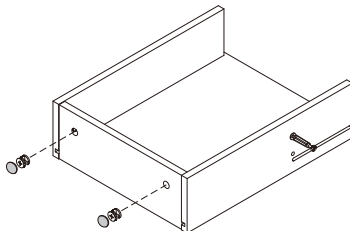
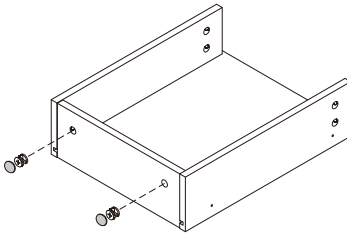

- Refer to the illustration, tighten the cam lock with the cover.

STEP 10

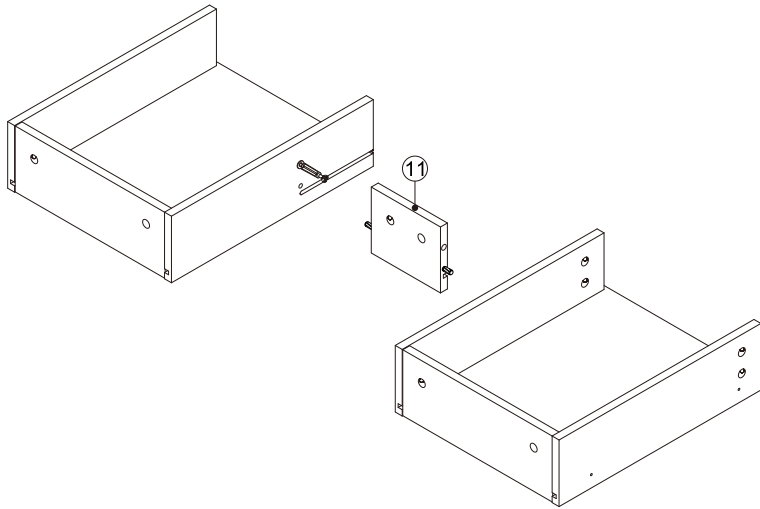

- Refer to the illustration, Insert the boards #11 into the finished board.

STEP 11

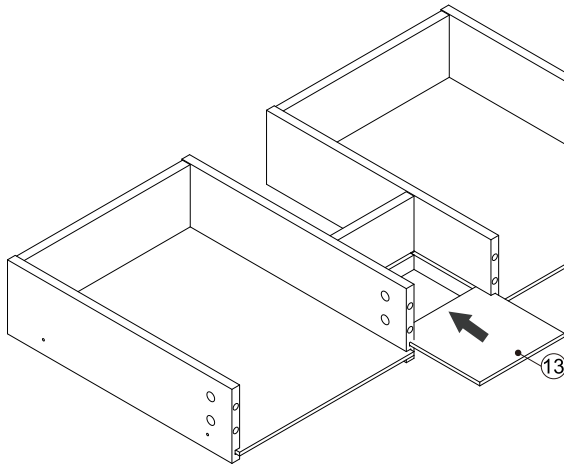

- Refer to the illustration, Insert the boards #13 into the finished board.

STEP 12

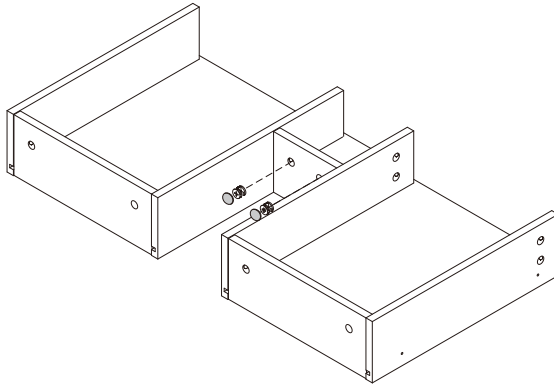

HARDWARE LIST			
E		2PCS	
I		2PCS	

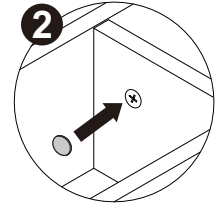
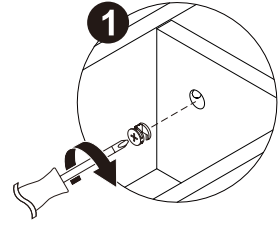

- Refer to the illustration, tighten the cam lock with the cover.

STEP 13

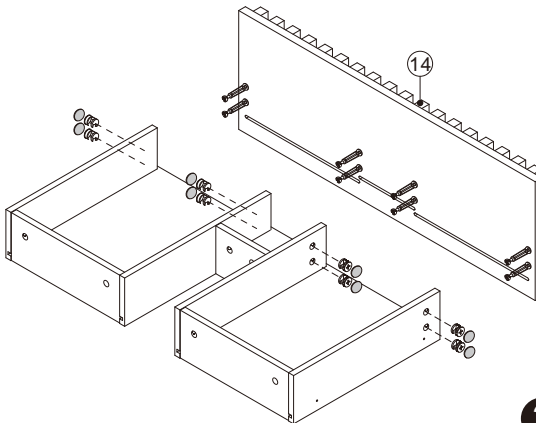

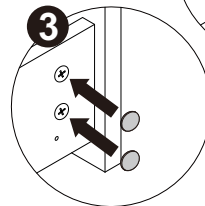
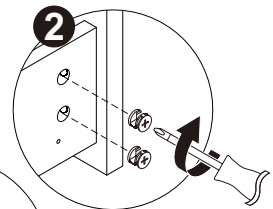
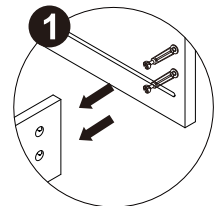

HARDWARE LIST			
E		8PCS	
I		8PCS	



- Refer to the illustration, Insert the board #14 into the finished board. Then tighten the cam lock with the cover.

STEP 14

HARDWARE LIST		
G		2PCS
F		6PCS

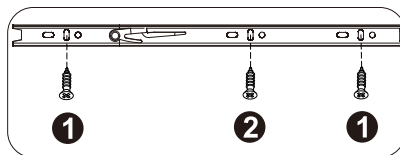
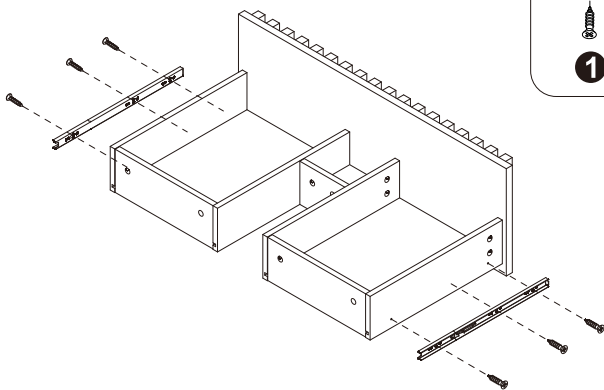

- Refer to the illustration, Apply screws to fix the slides on the boards #6,#7.

STEP 15

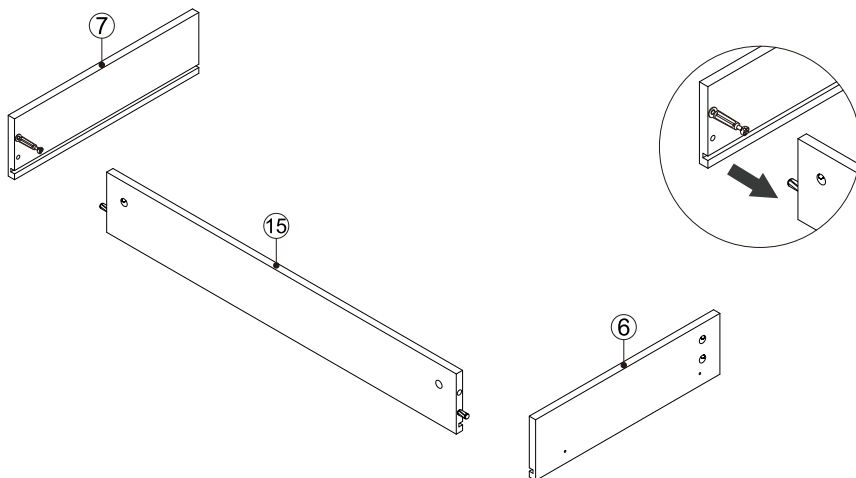

- Refer to the illustration, Connect the boards #6,#7,#15.

STEP 16

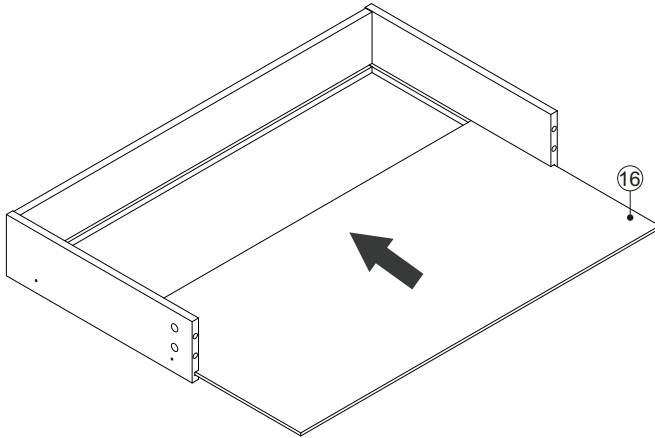

- Refer to the illustration, Insert the boards #16 into the finished board.

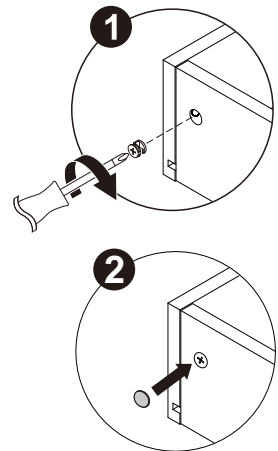
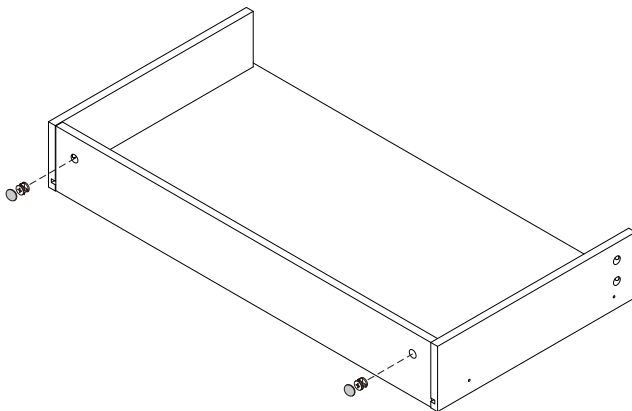

STEP 17

HARDWARE LIST			
E		2PCS	
I		2PCS	

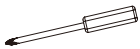

- Refer to the illustration, tighten the cam lock with the cover.

STEP 18

HARDWARE LIST			
E		4PCS	
I		4PCS	

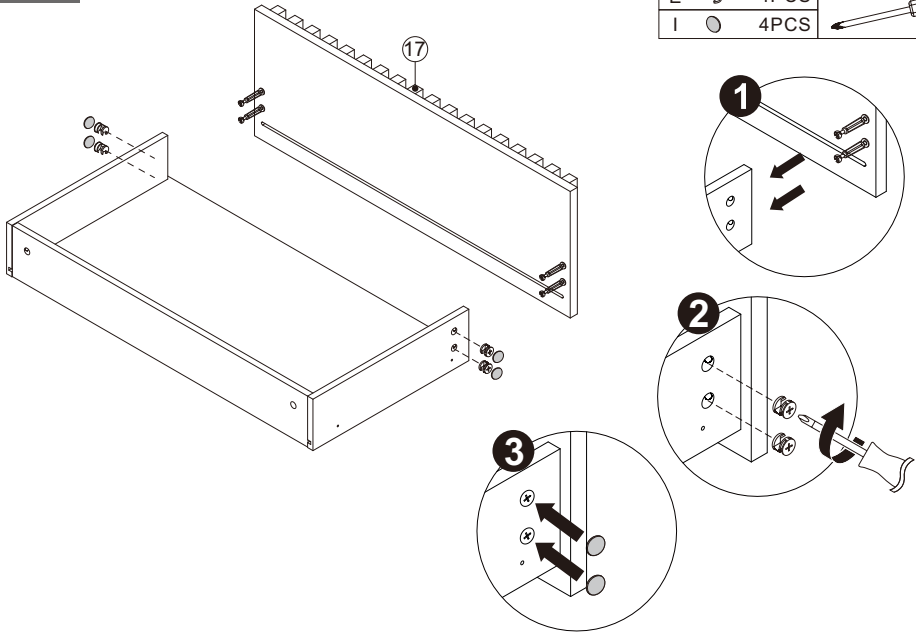

- Refer to the illustration, Insert the board #17 into the finished board. Then tighten the cam lock with the cover.

STEP 19

HARDWARE LIST			
G		2PCS	
F		6PCS	

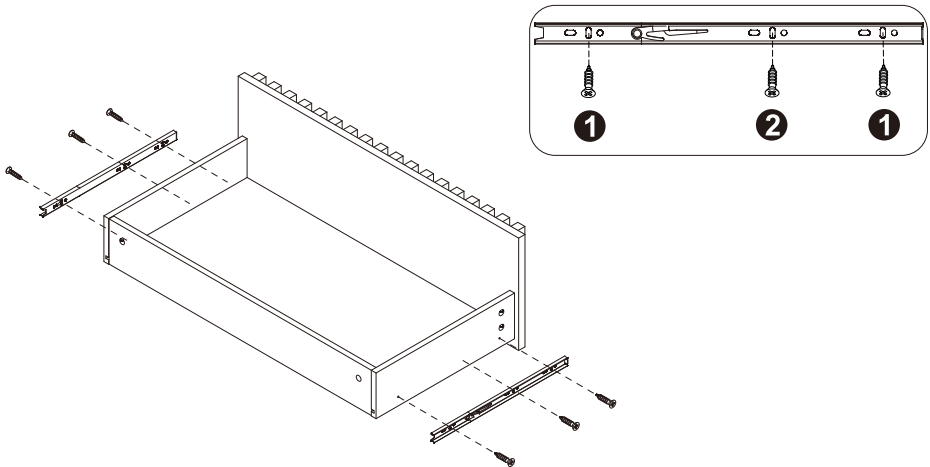

- Refer to the illustration, Apply screws to fix the slides on the boards #6,#7.

STEP 20

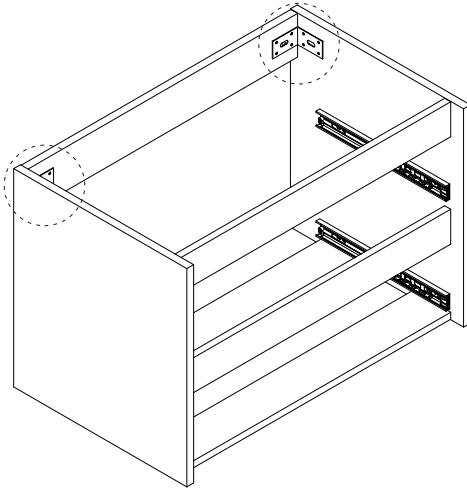



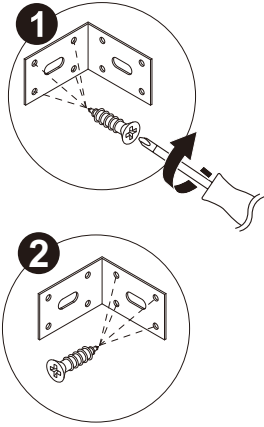

HARDWARE LIST		
F		16PCS
H		2PCS

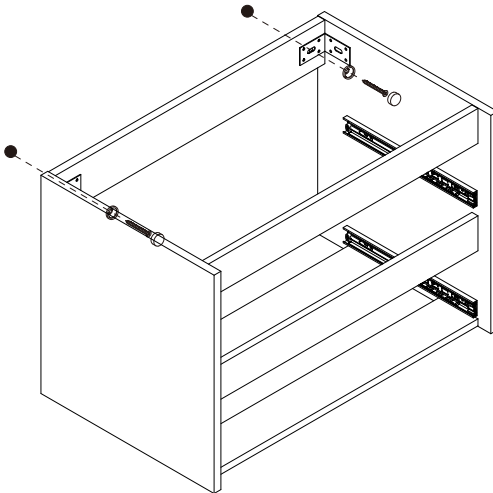

- Refer to the illustration, use screws to secure the bracket to the board.

STEP 21



HARDWARE LIST		
K		2PCS
K		2PCS
K		2PCS
K		2PCS

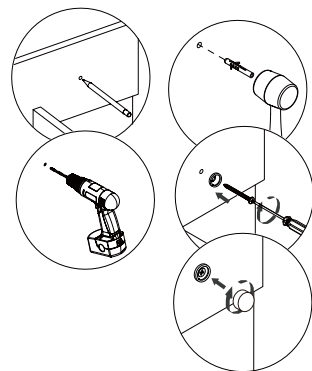

- Refer to the illustration, draw the spacing between the walls on the cabinet, punch holes in the wall, and fix the cabinet to the wall with screws. Then tighten the nut cover.

STEP 22

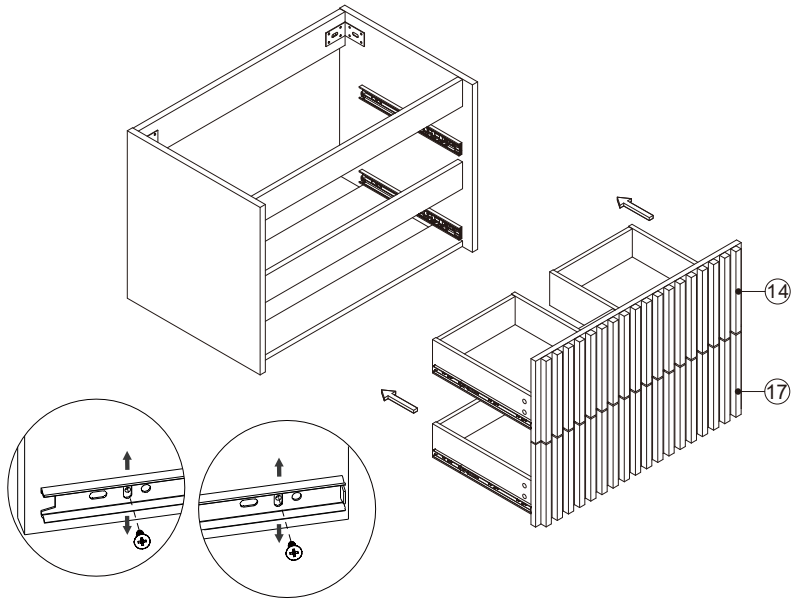

- If the drawers are not in the same level, please adjust the screws in the drawer box.
- Assembled drawers are loaded onto cabinets.

STEP 23

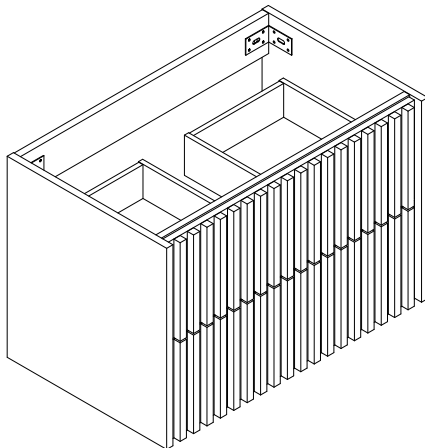

- To help prevent mildew, apply sealant to the space between the wall and the edge of the cabinet.

CARE AND CLEANING

1. Many cleansers contain abrasive and chemical substance which is not suitable for cleaning stainless steel, enamel, plating or plastic products. You may use mild cleansers or soaps to clean the surfaces. Wipe any splashes of cleaner solutions from the surface with a clean soft cloth.
2. Maintain ventilation in the bathroom and separate the dry area from the damp one if conditions permit. Try to open the door and windows of the bathroom to maintain adequate ventilation.
3. This cabinet is built to withstand normal bathroom humidity. For best results, keep this vanity dry and take necessary steps to minimize bathroom humidity by opening windows and doors and using the exhaust fan (if available).
4. To maintain the cabinet door, clean and wipe the door regularly with a soft cloth. Wipe condensation with a dry, soft cloth. Keep away from resin and high temperatures.
5. Please do not sit, lean or step on the basin cabinet.

FEEDBACK ★★★★★

Thank you very much for purchasing from us.

We have always been trying to provide the best service and reliable products for every customer.

We sincerely hope you will be satisfied with our products and leave us FIVE STARS and POSITIVE feedback/review in our page.

However, accident may happen sometimes, please contact us to resolve any issue before leaving a negative feedback.

Many thanks and welcome to our shop again!

Contact number: (323)-393-8260

E-mail: service@eclifeusa.com