

Assembly instructions

Easy-to-Understand Installation Guide

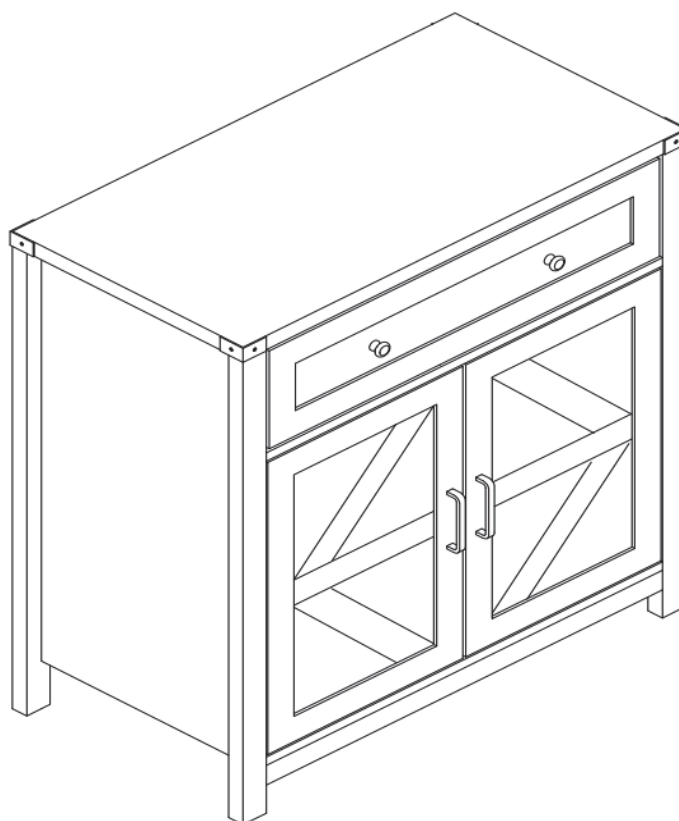

If any parts are received damaged or defective, please contact us.

We are happy to send replacement parts to ensure you have a fully functional product.

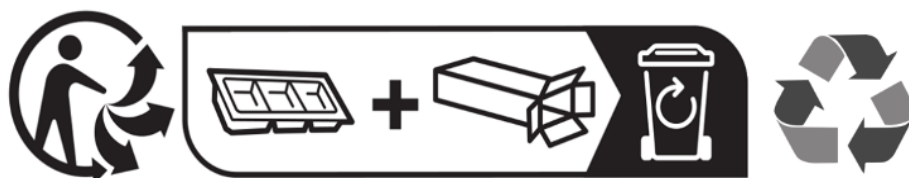

CAM LOCK/BOLT FASTENING INTRODUCTION

(You will use it during assembly)

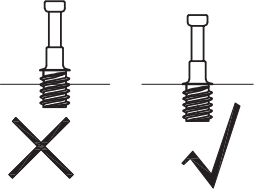
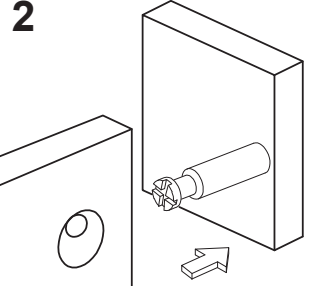
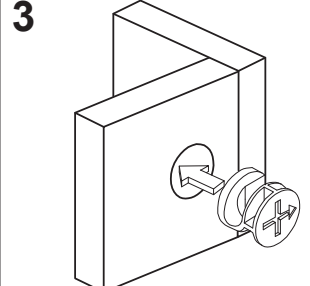
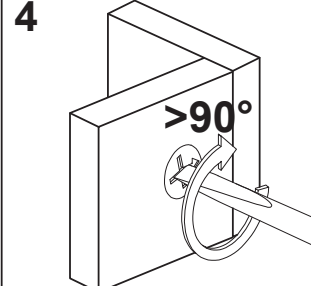
			
<p>1.Screw cam bolt into the threaded anchor gently. (Attention:don't screw cam bolt too deep or too shallow.)</p>	<p>2.Please connect the two boards you want connect by inserting cam bolt.</p>	<p>3.Insert the cam lock into the round hole of the board. (Attention:point the arrow on the top of the cam lock to the outer edge.)</p>	<p>4.Turn the cam lock clockwise until it is firmly tightened.</p>



IMPORTANT INFORMATION

READ CAREFULLY.

KEEP THIS INFORMATION FOR FURTHER REFERENCE.

GENERAL GUIDELINES

If you have any questions about the product or assembly, please kindly contact us at any time, we will solve your problem asap.

WARNINGS

1. Please be careful and slowly when opening and assembling the product, especially keep the parts and packaging away from children to avoid accidental injury.
2. Please avoid using aggressive chemicals/cleaners to avoid damaging the product surface.
3. Don't push or pull the product to avoid damaging your floor.
4. Don't throw away any packing materials and accessories until assembly is complete.

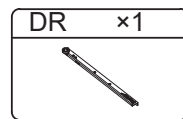
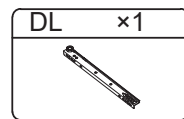
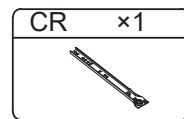
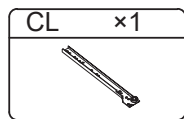
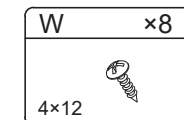
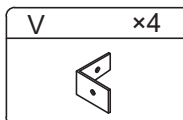
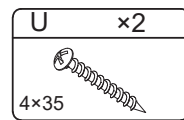
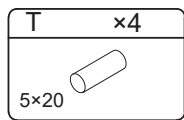
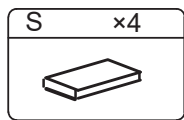
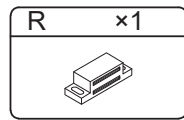
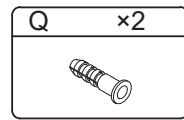
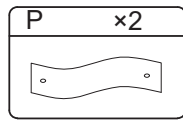
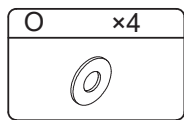
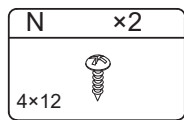
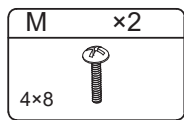
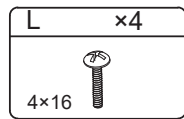
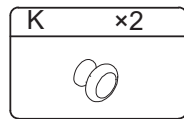
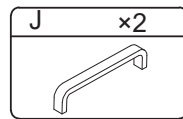
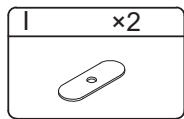
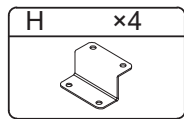
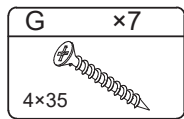
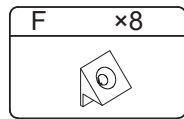
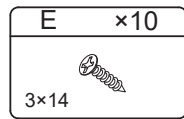
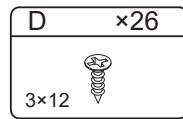
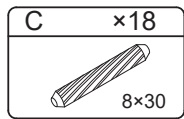
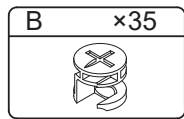
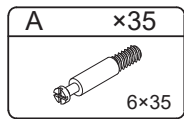
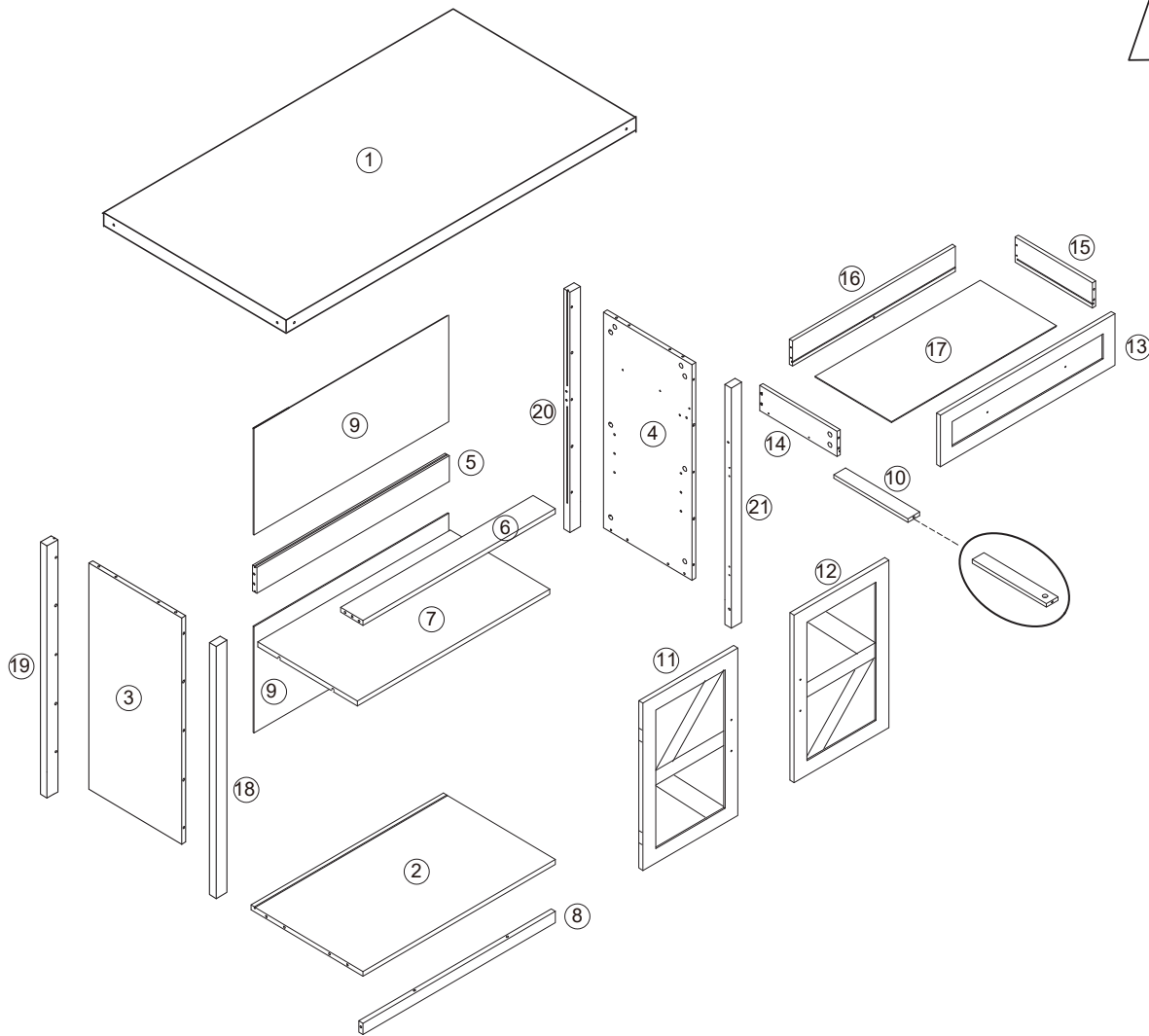

1

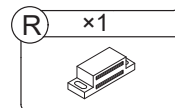
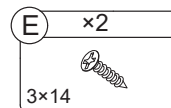
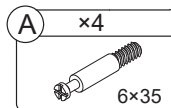
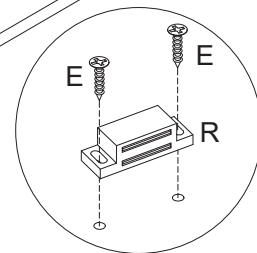
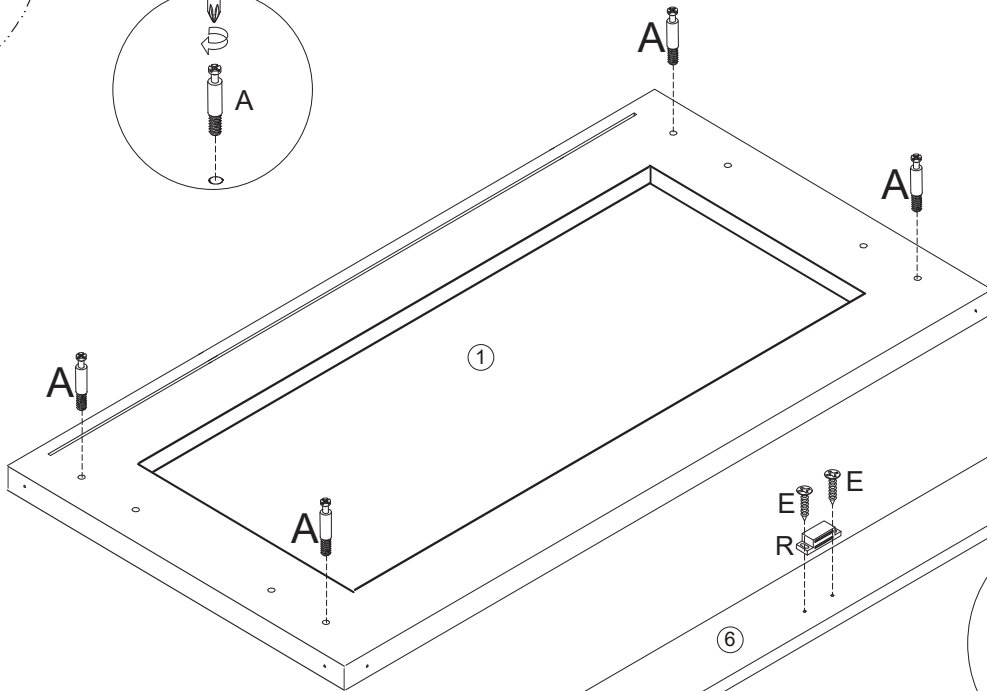
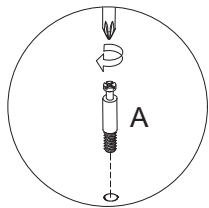

2

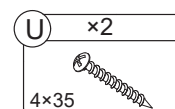
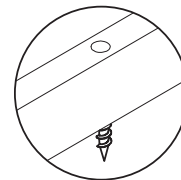
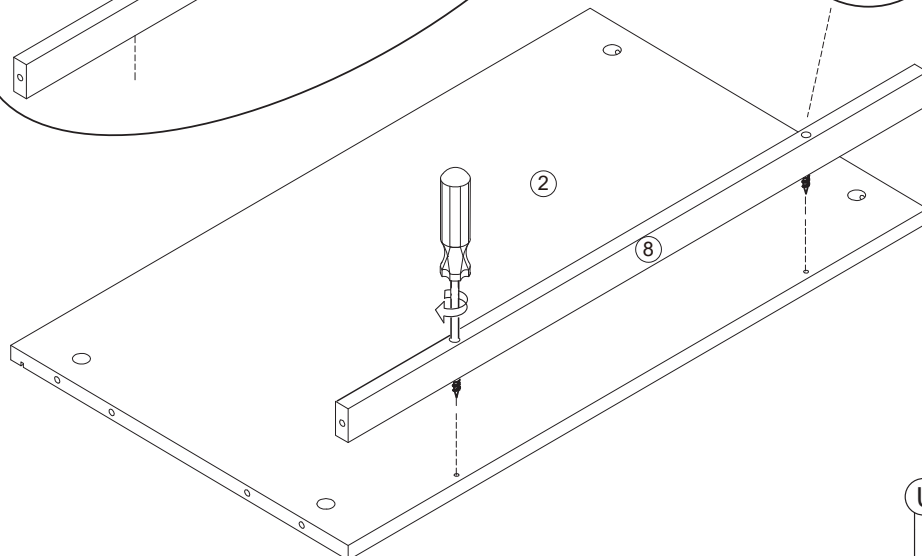
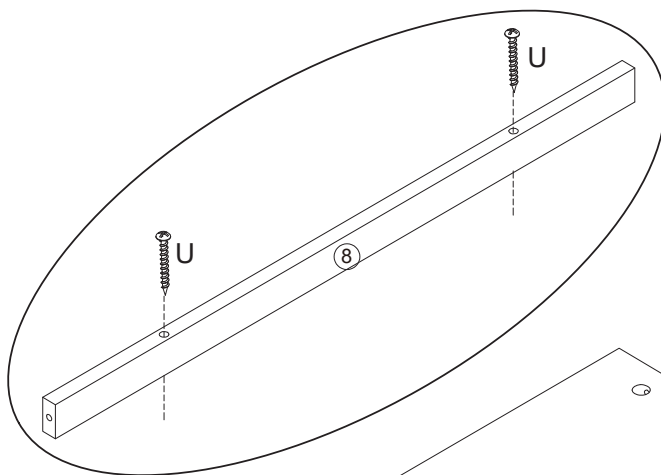

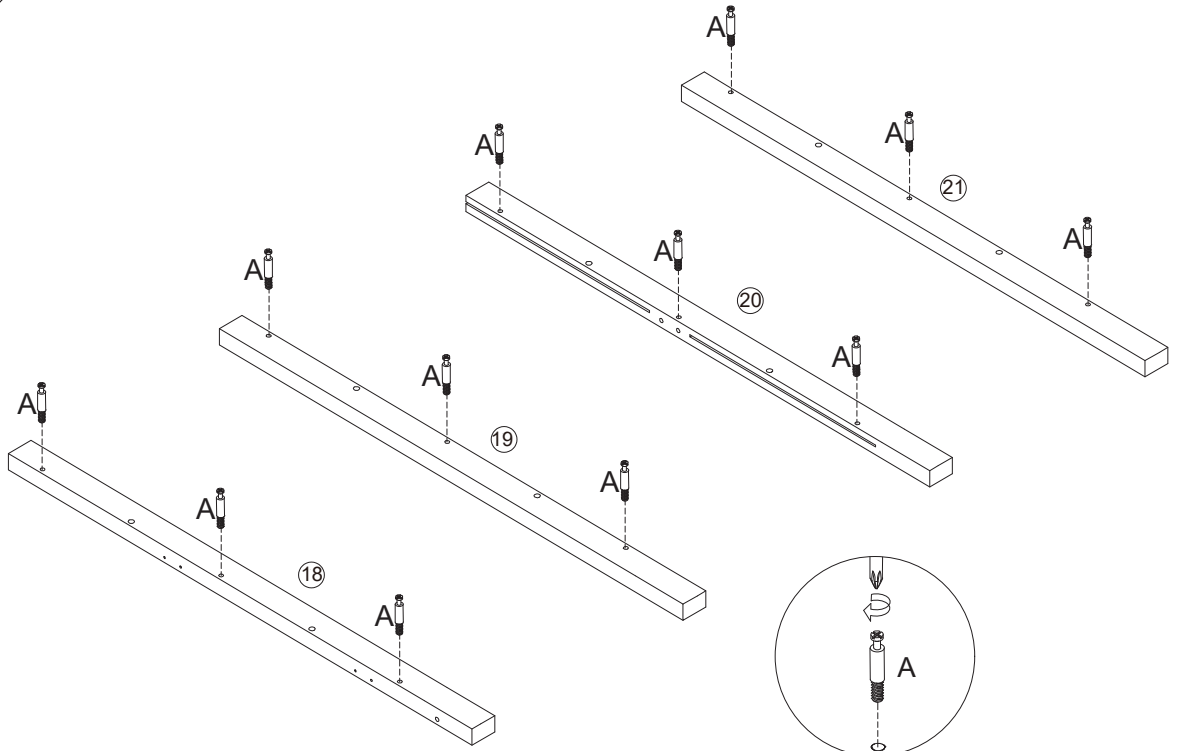
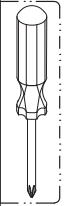

3

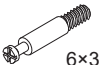

A	x12
	6x35

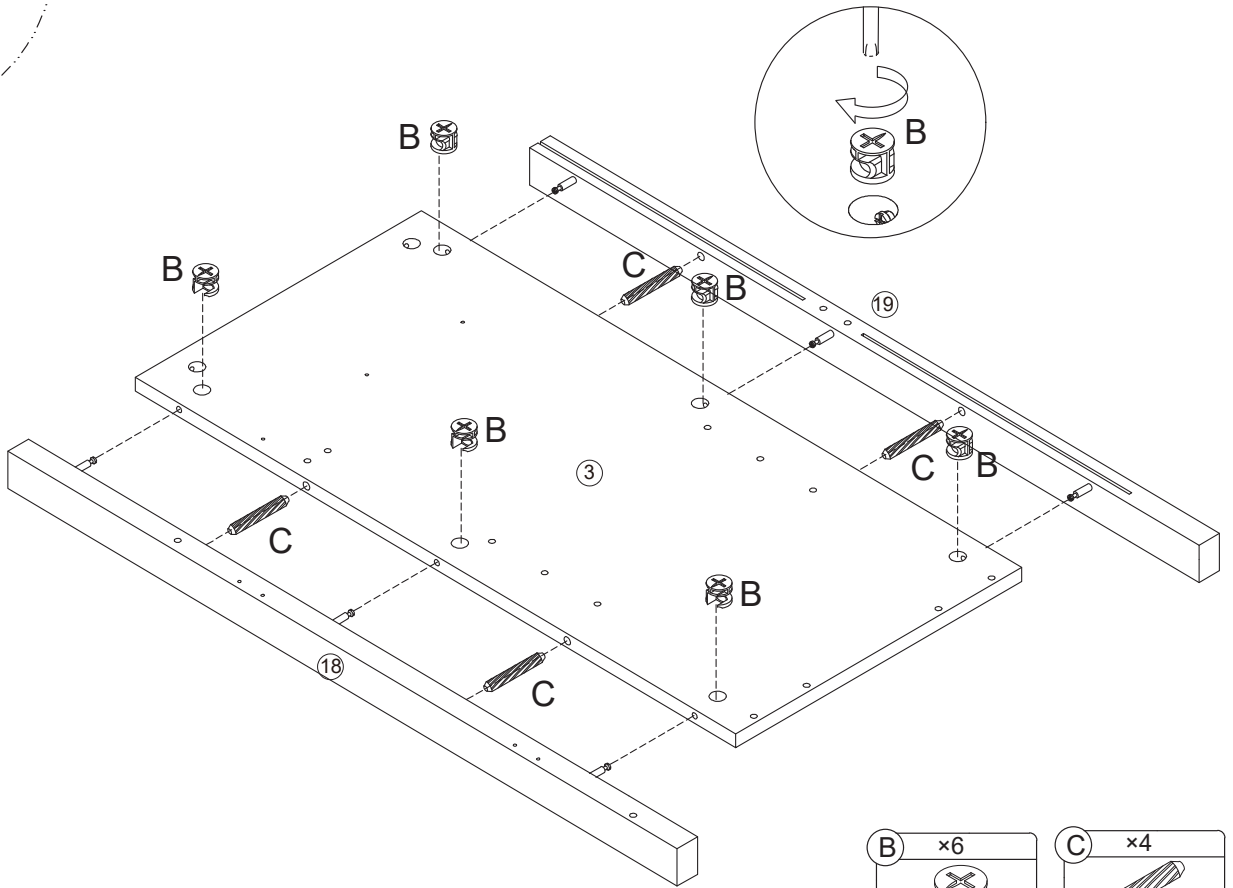
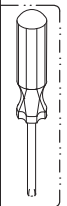
4

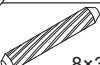

B	x6
	

C	x4
	8x30

5

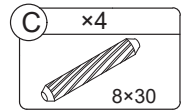
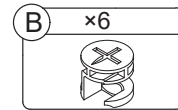
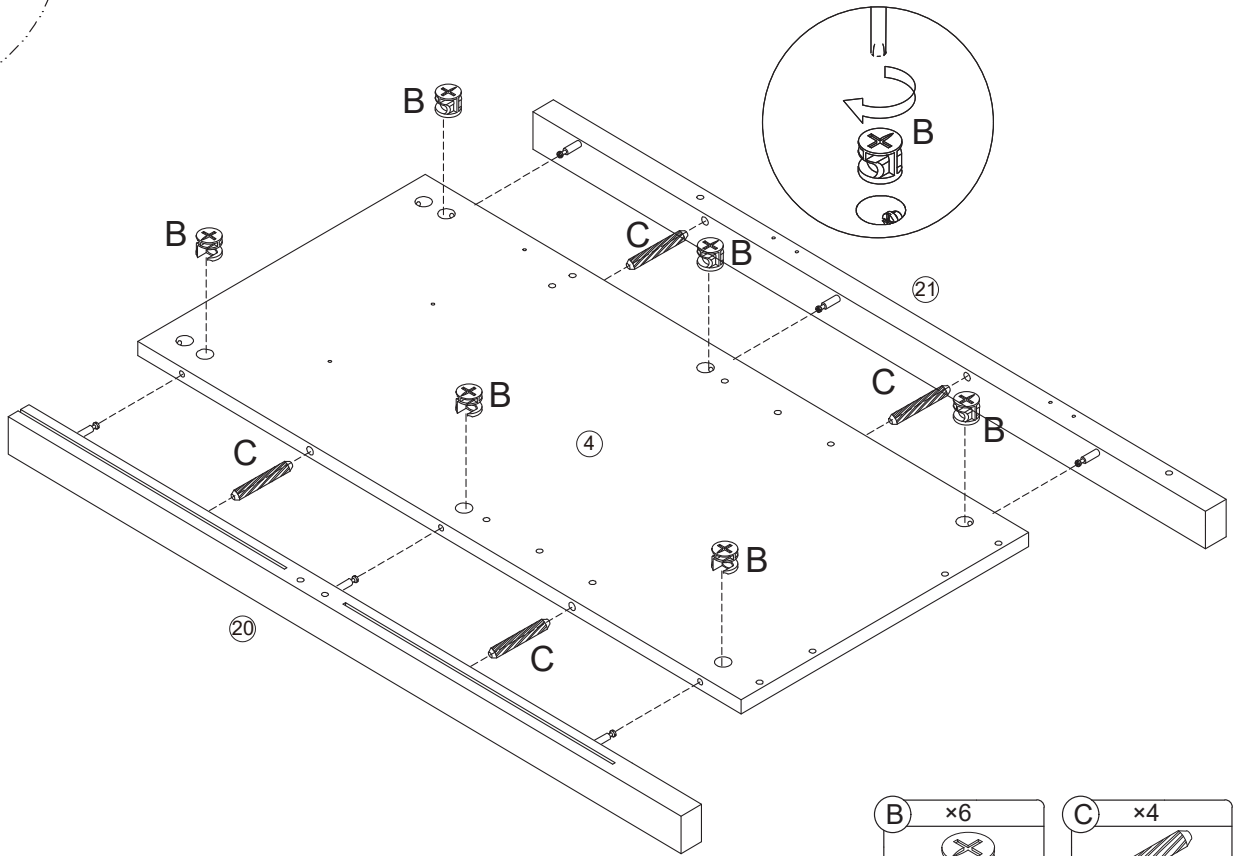

6

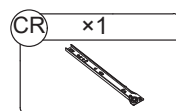
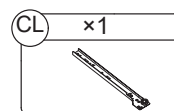
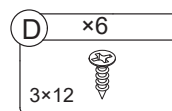
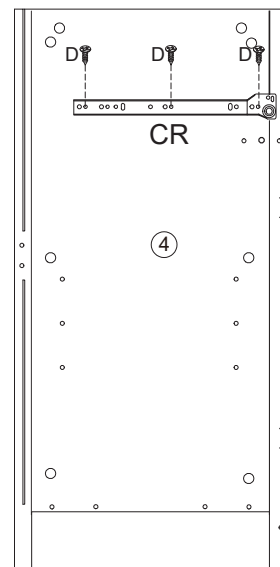
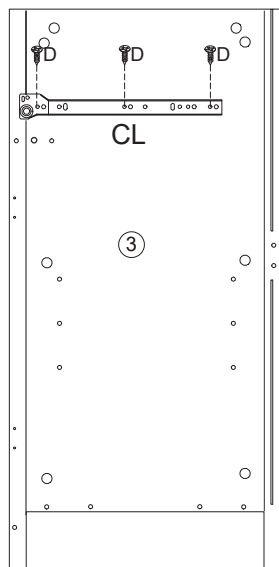
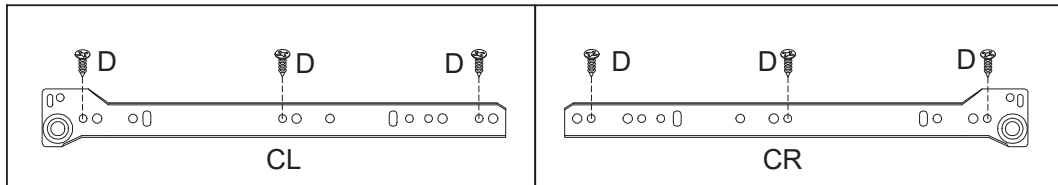

7

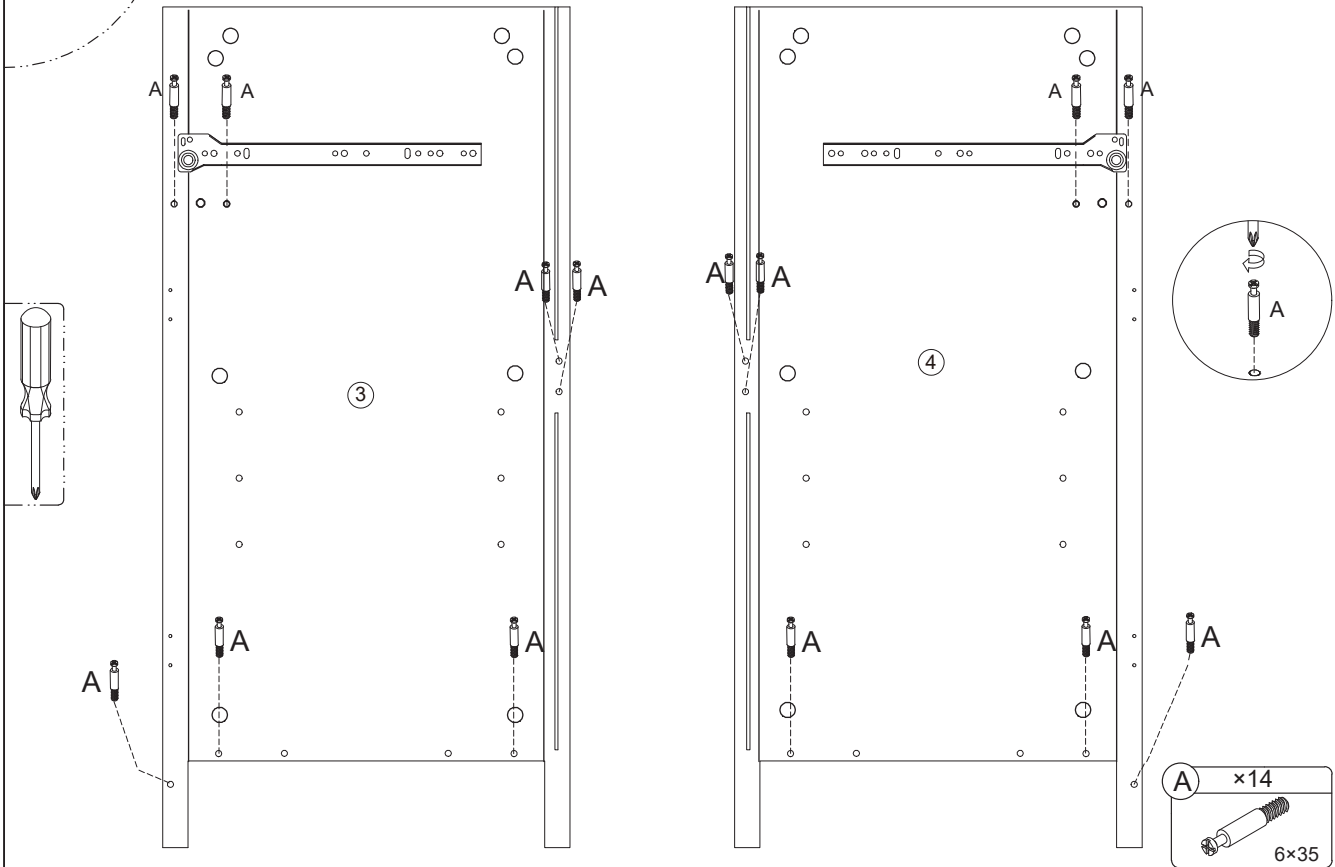

8

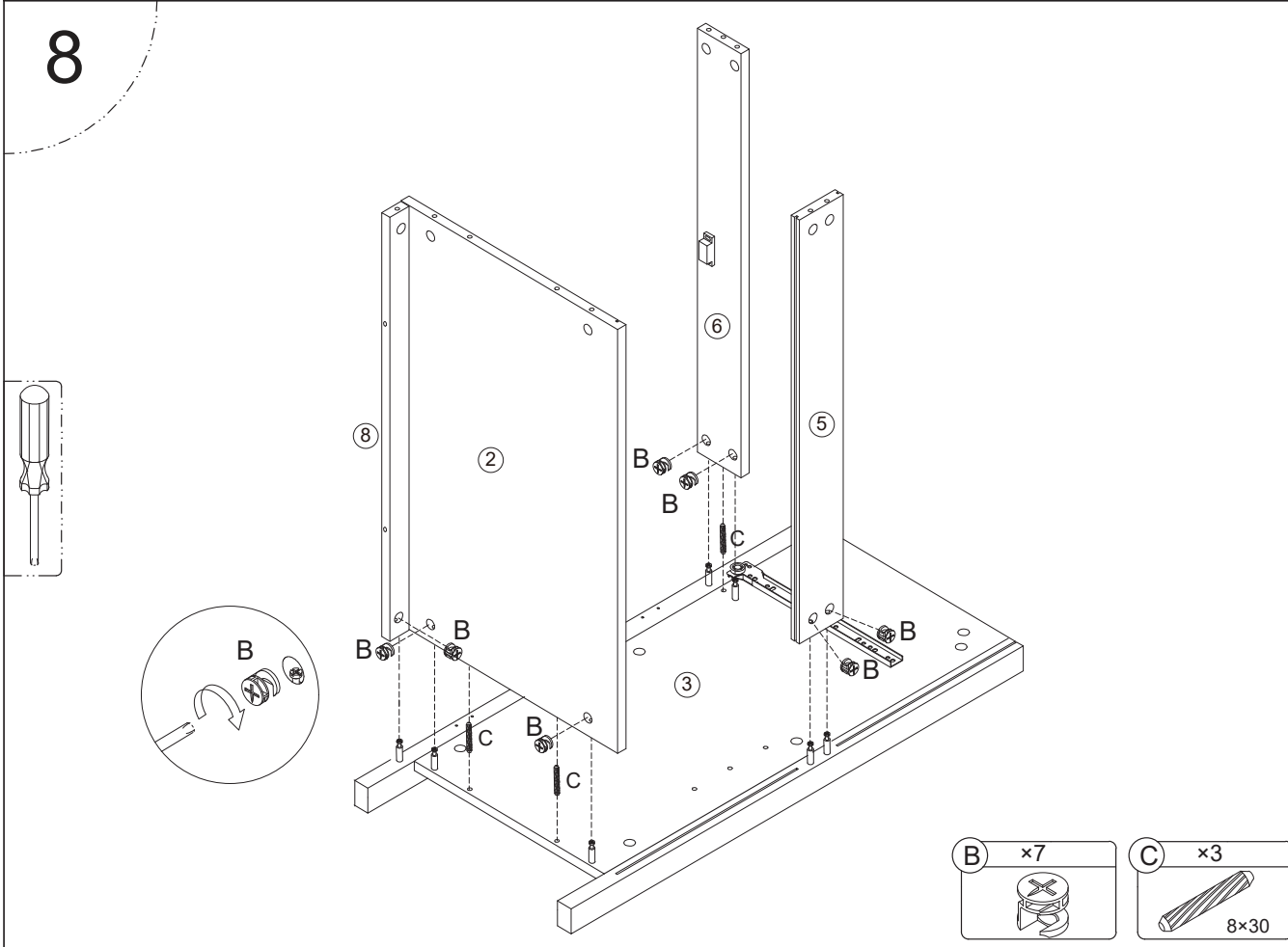

9

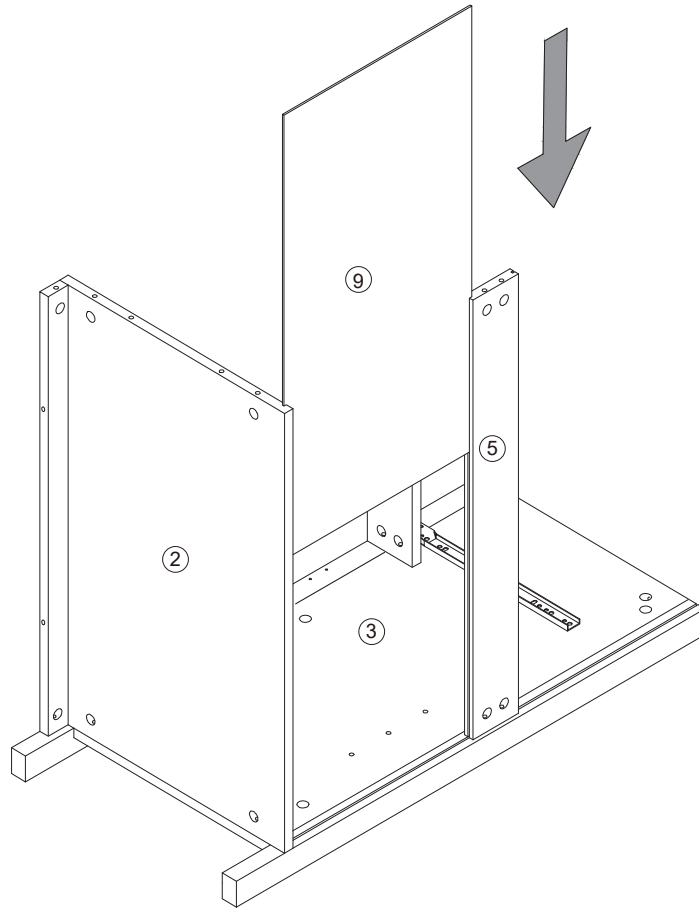

10

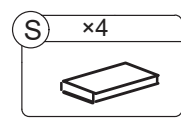
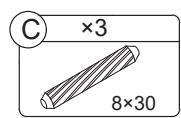
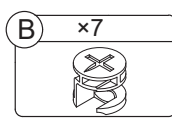
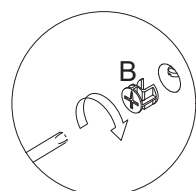
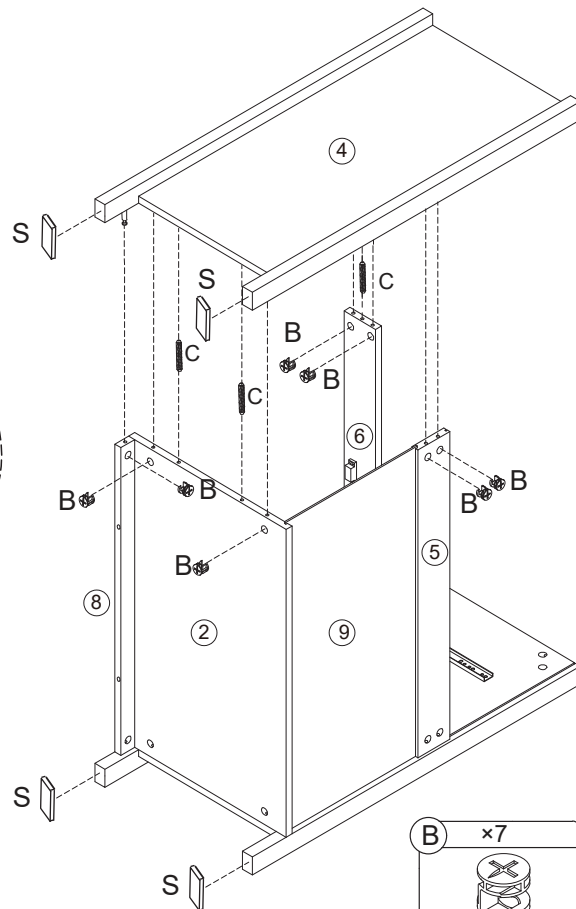
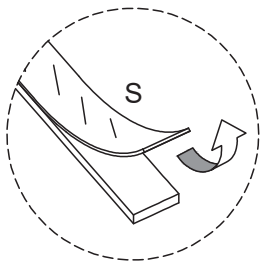
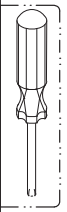

11

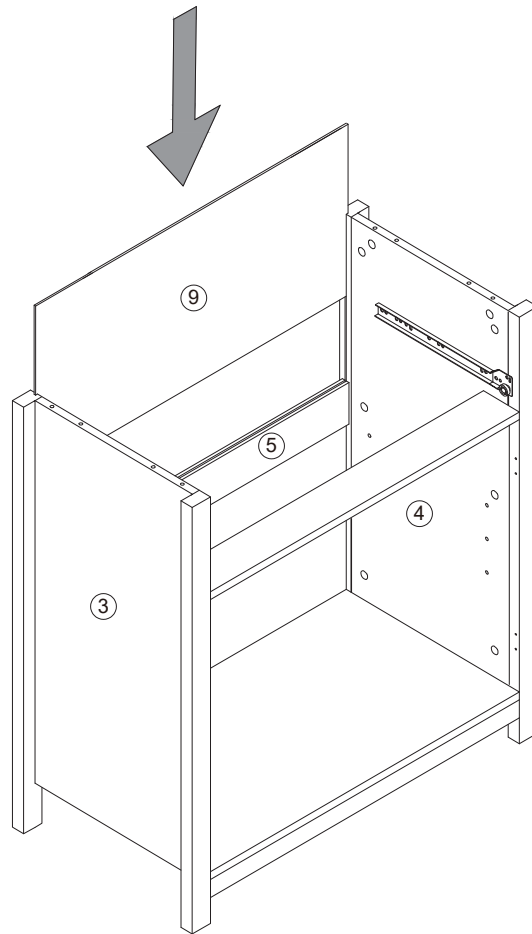

12

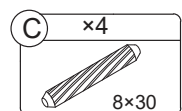
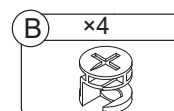
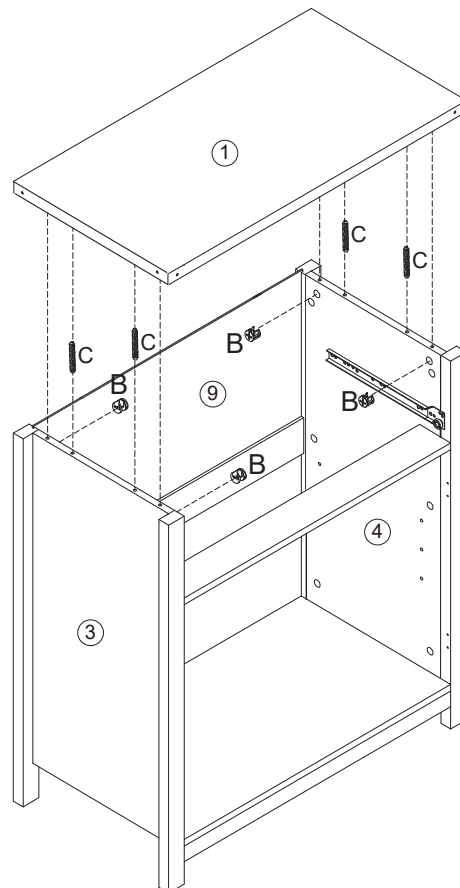
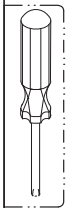

13

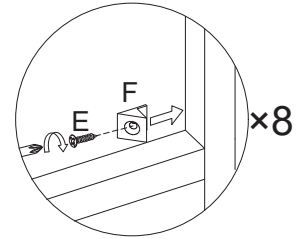
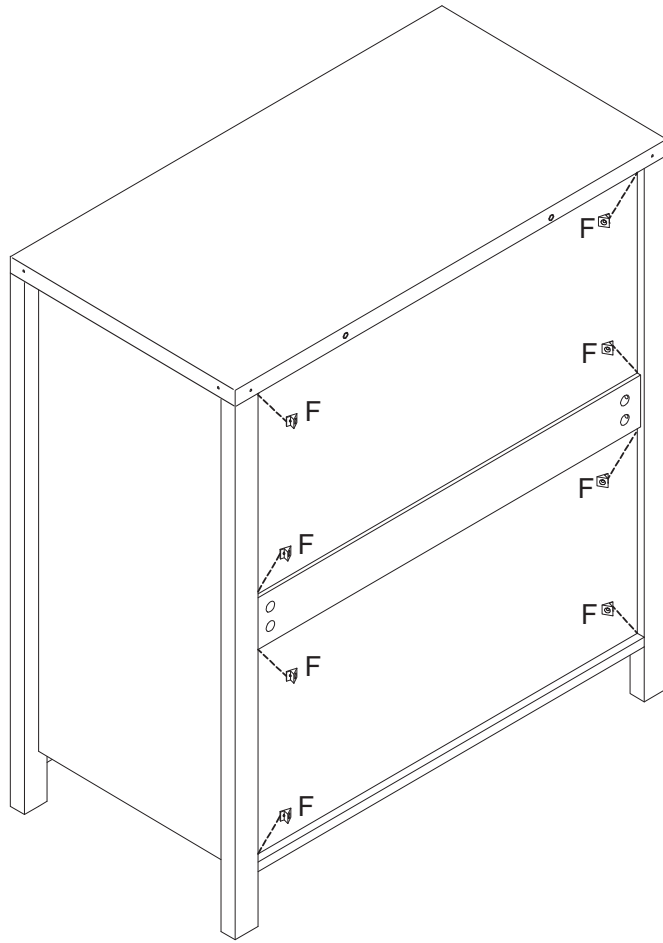
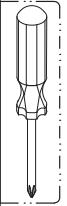

x8

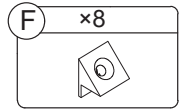
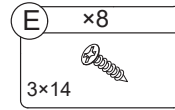

14

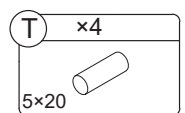
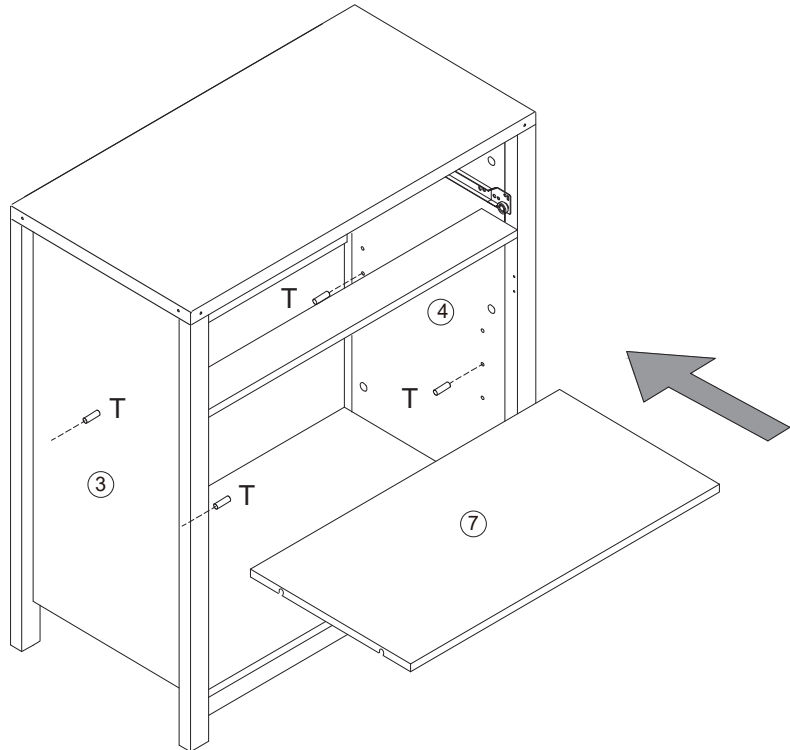

15

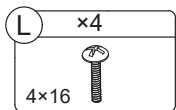
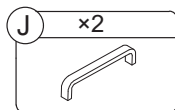
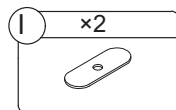
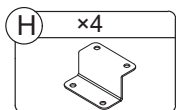
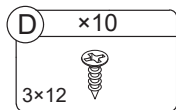
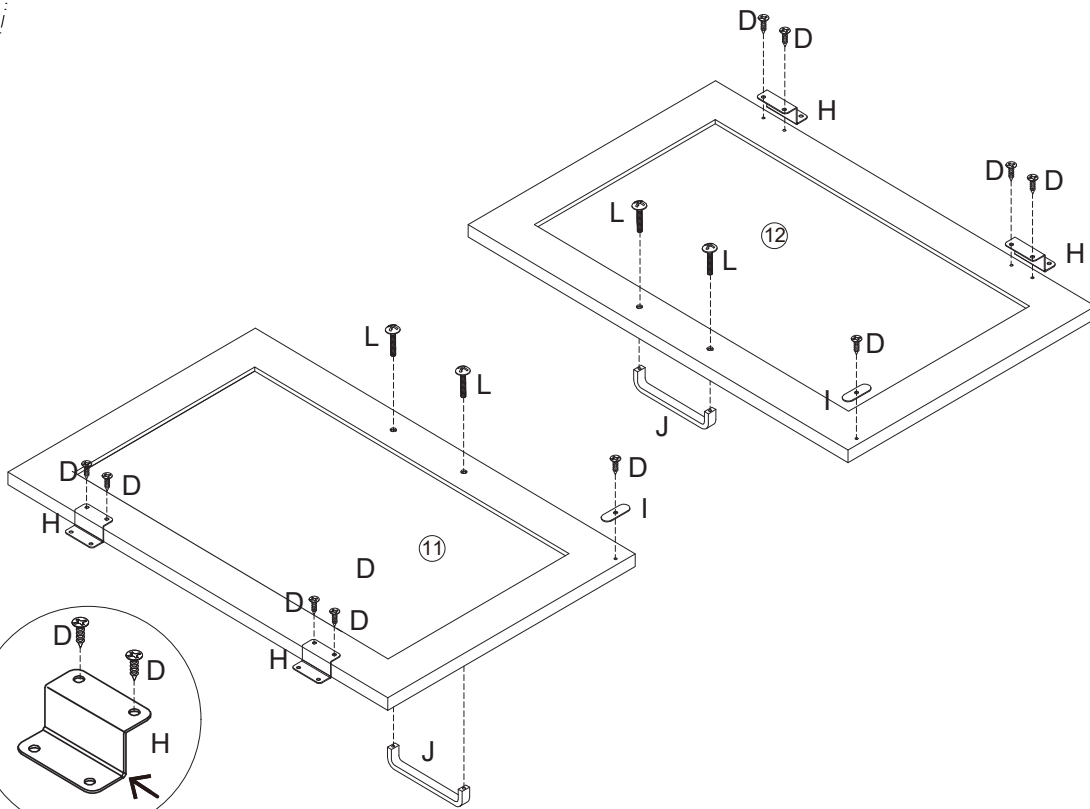
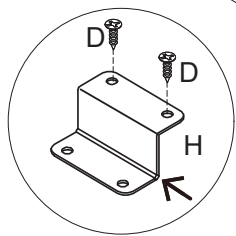
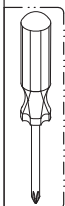

16

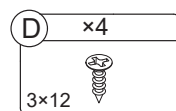
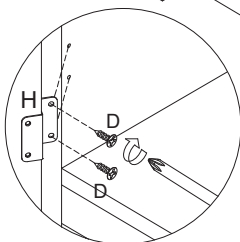
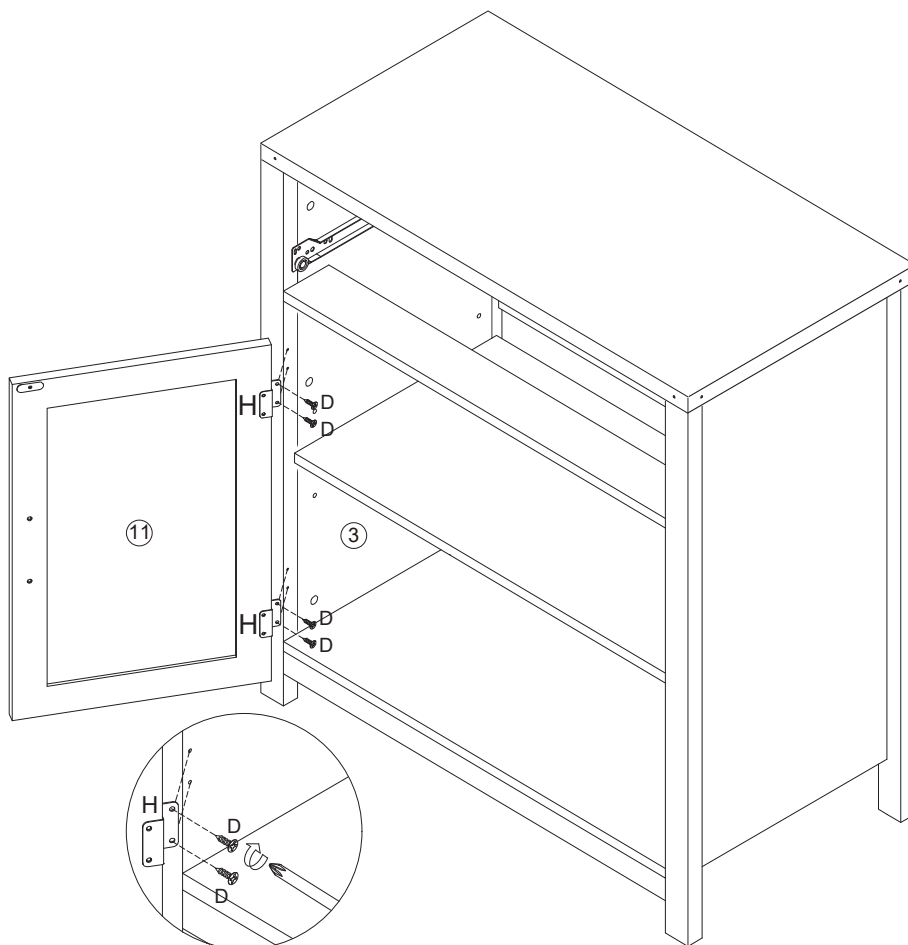
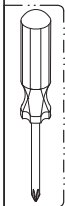

17

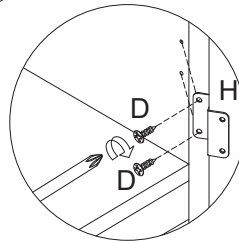
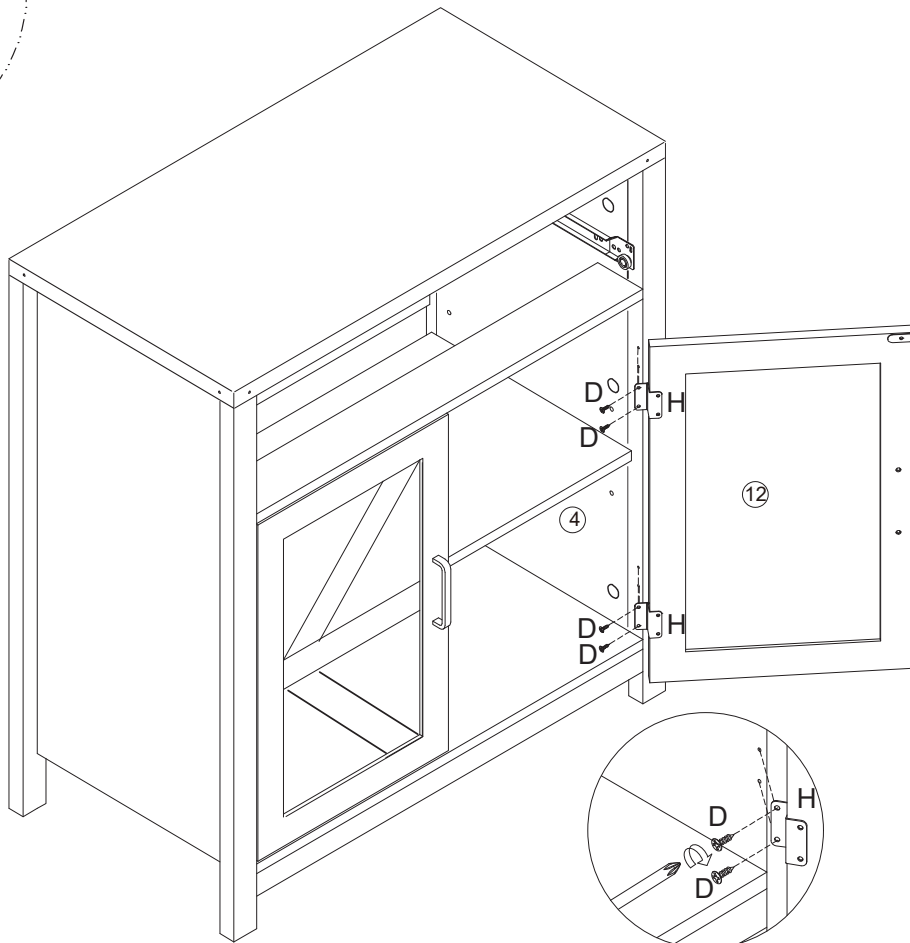
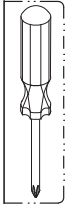

D	x4
3x12	

18

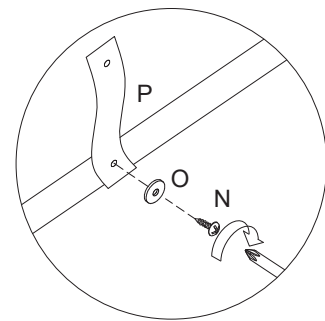
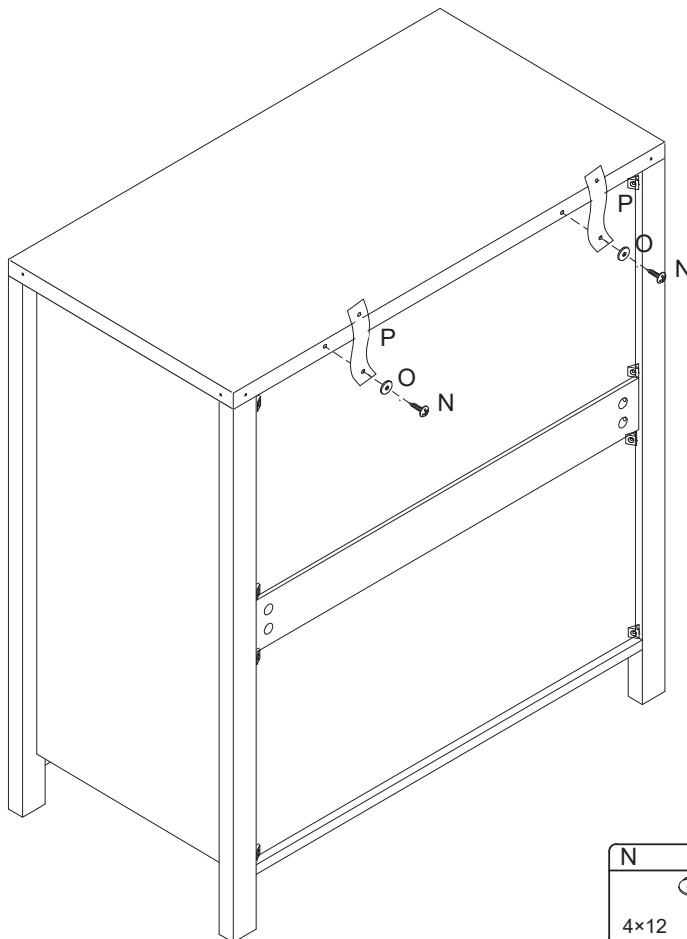
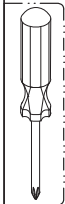

N	x2
4x12	

O	x2

P	x2

19

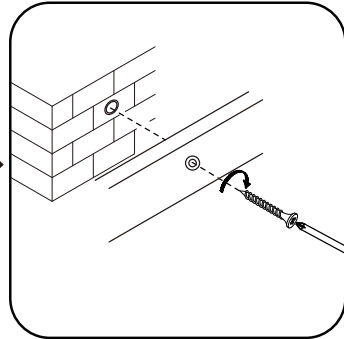
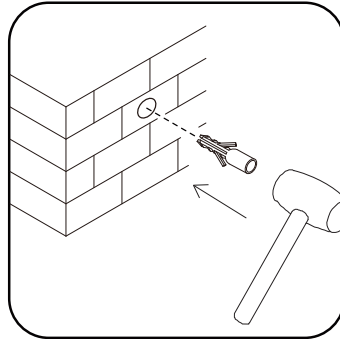
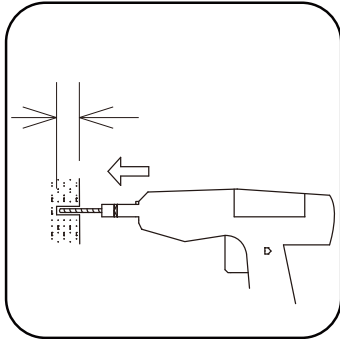
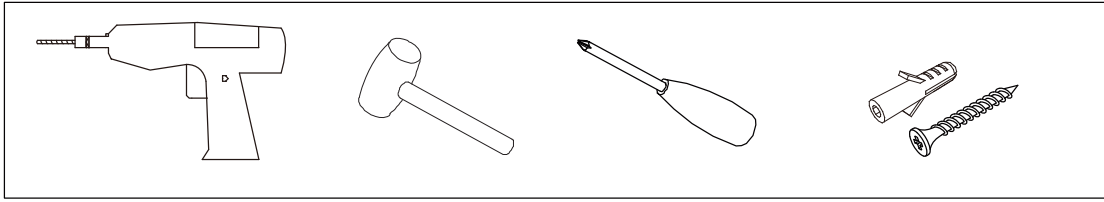

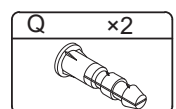
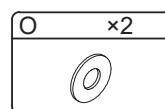
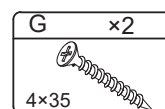
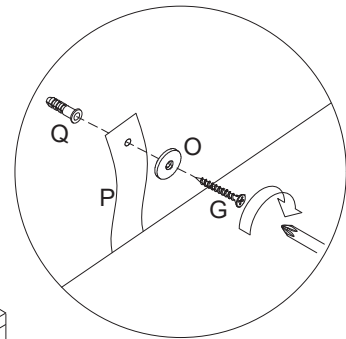
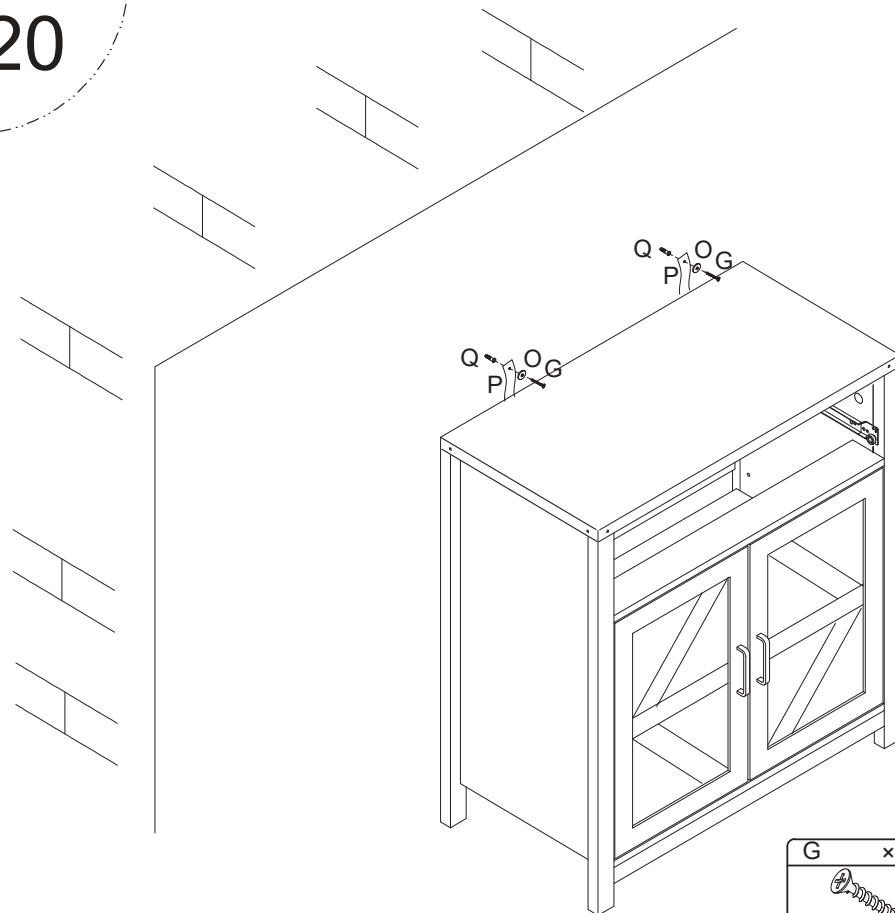

20



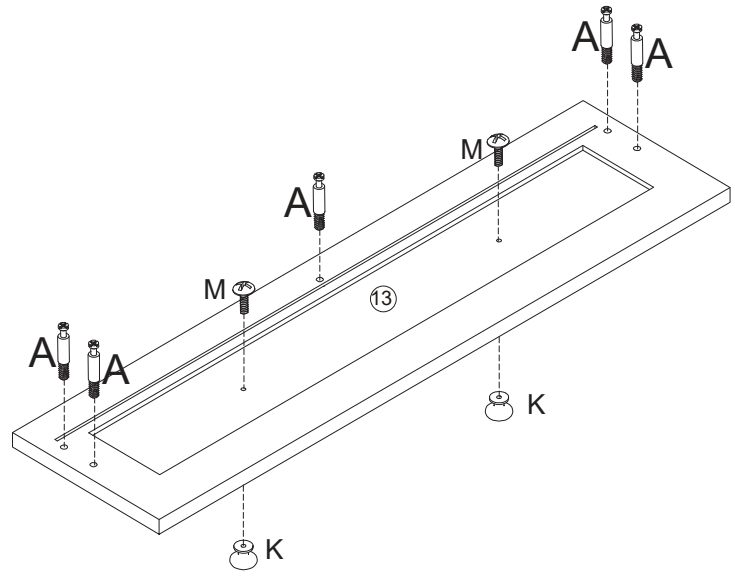
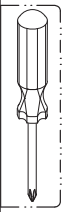

21

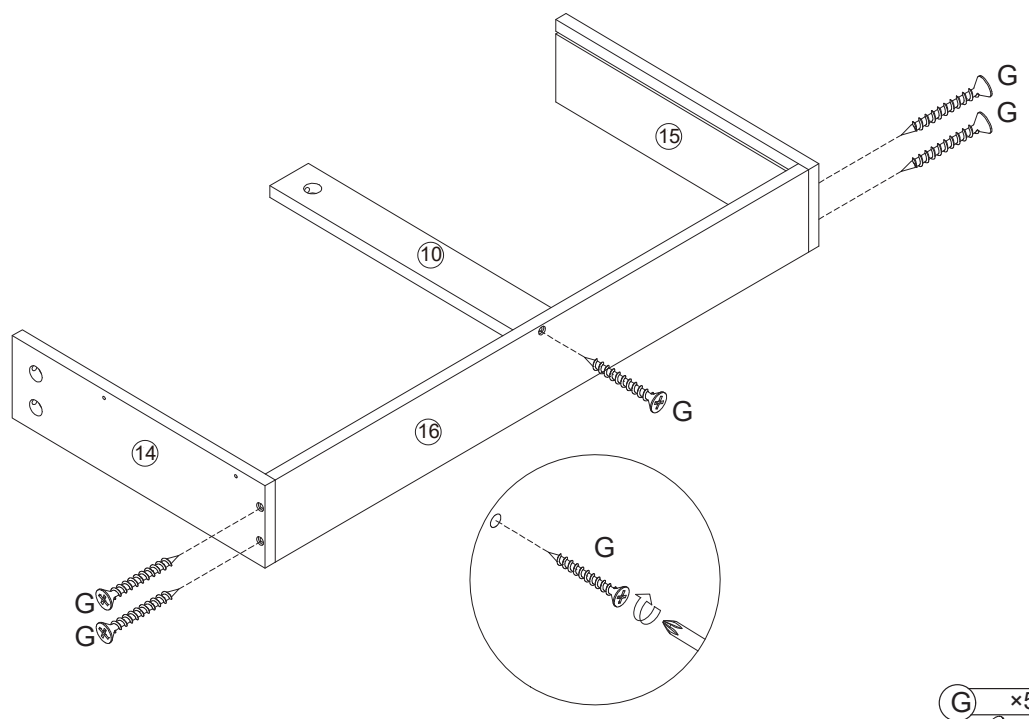
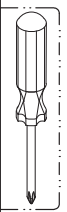

- | | | |
|--|--|--|
| A ×5 | K ×2 | M ×2 |
|  6×35 |  |  4×8 |

22



- | |
|--|
| G ×5 |
|  4×35 |

23

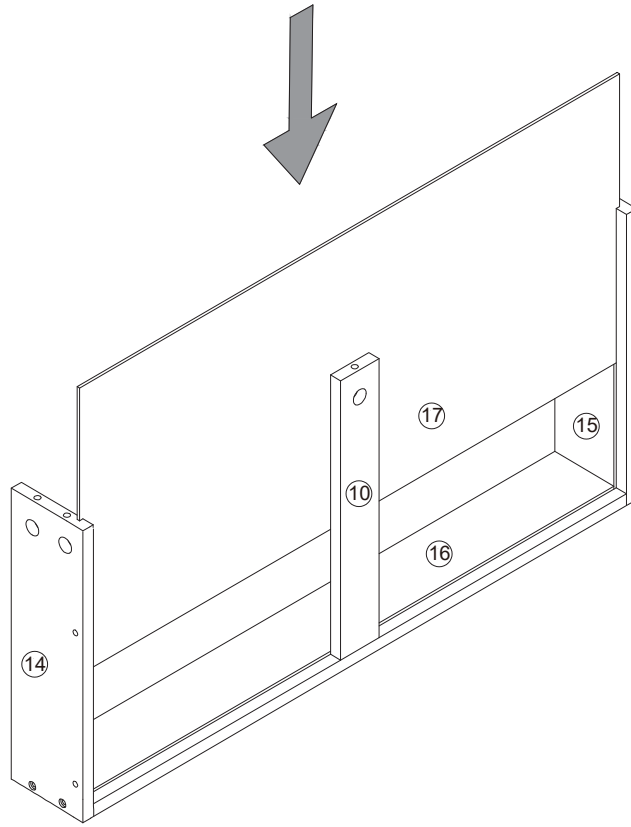

24

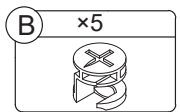
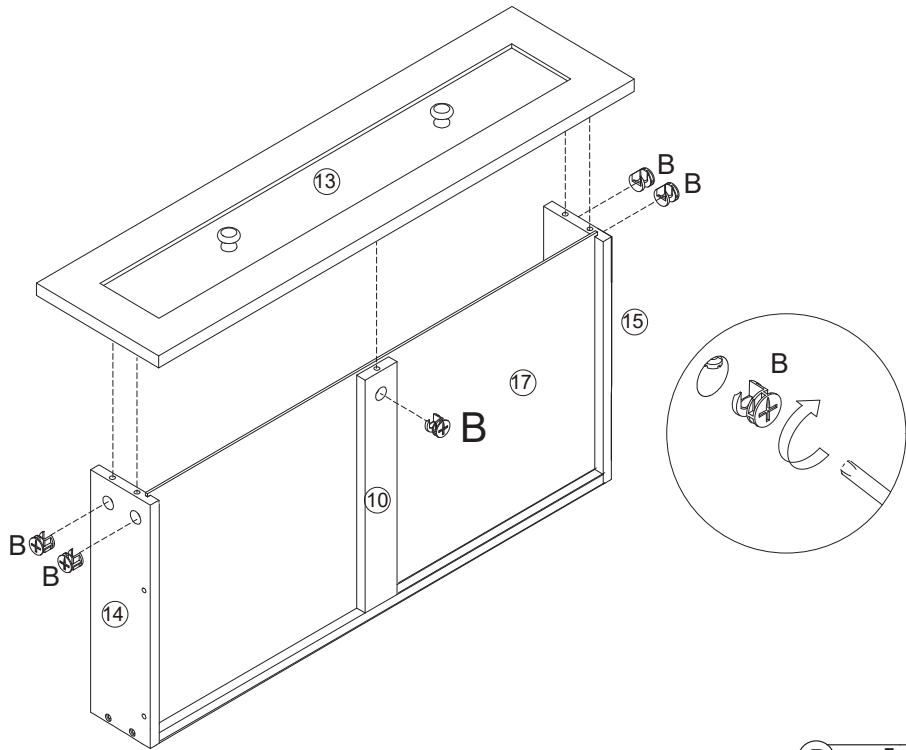
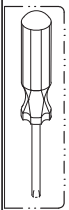

25

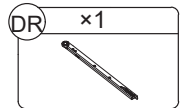
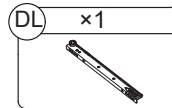
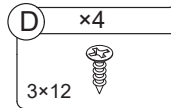
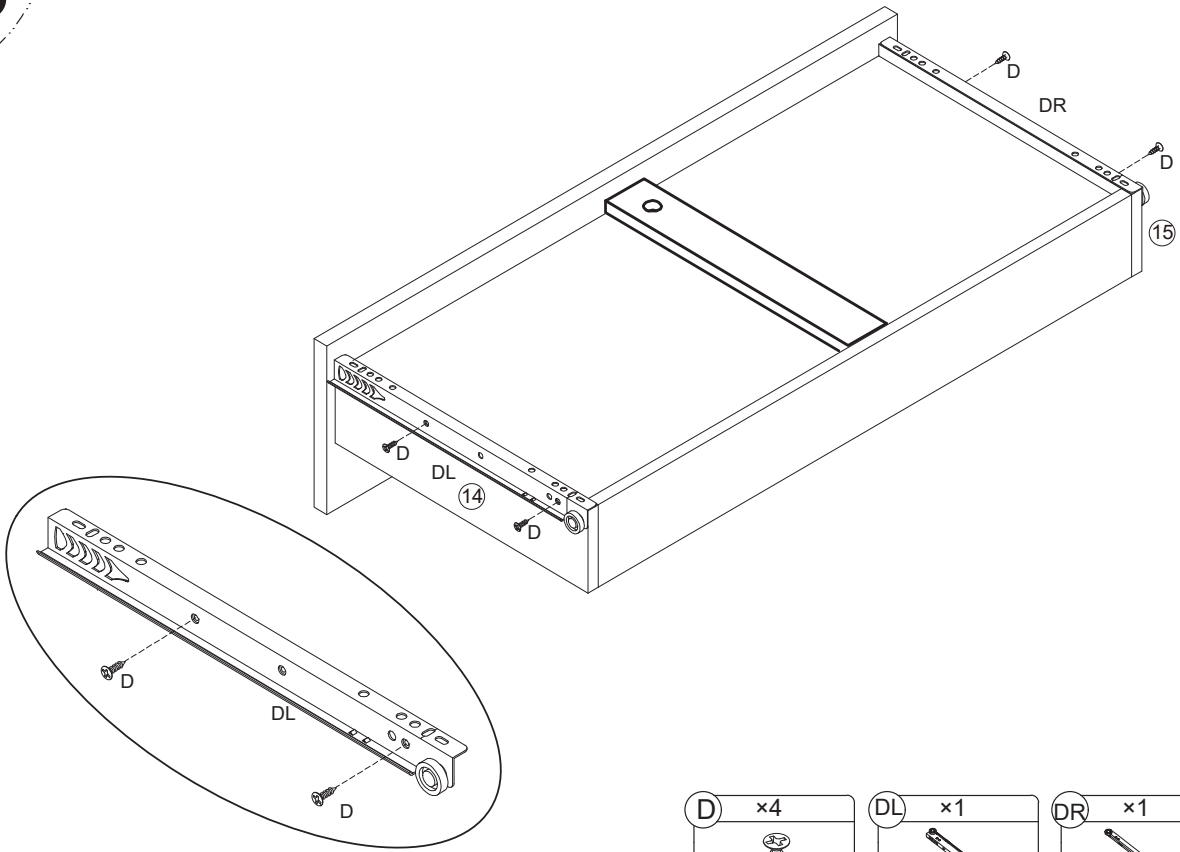
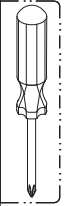

26

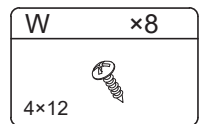
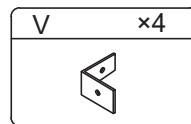
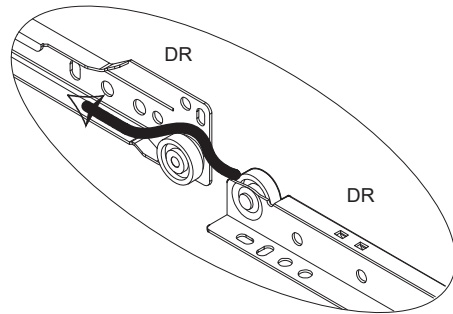
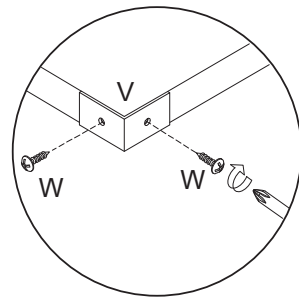
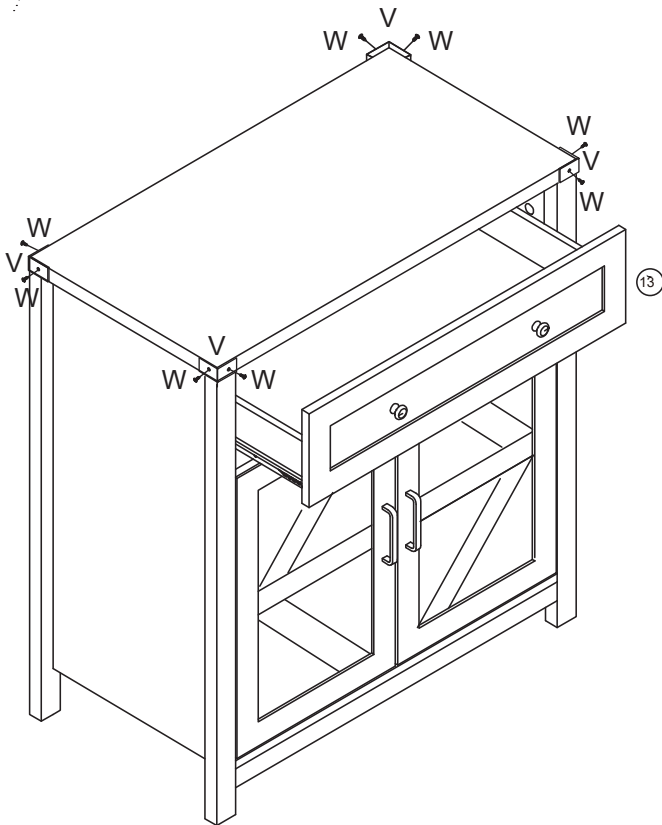

WARNING



Children have died from furniture tipover. To reduce the risk of furniture tipover:

- ALWAYS install tipover restraint provided.
- NEVER put a TV on this product.
- NEVER allow children to stand, climb or hang on drawers, doors, or shelves.
- NEVER open more than one drawer at a time.
- Place heaviest items in the lowest drawers.
- Do not defeat or remove the drawer interlock system.

This is a permanent label.

Do not remove!

ATTENTION



Des enfants sont morts du basculement des meubles. Pour réduire le risque de basculement des meubles:

- TOUJOURS installer la retenue de basculement fournie.
- NE JAMAIS mettre de téléviseur sur ce produit.
- NE JAMAIS permettre aux enfants de se tenir debout, de grimper ou de s'accrocher à des tiroirs, des portes ou des étagères.
- N'ouvrez JAMAIS plus d'un tiroir à la fois.
- Placez les objets les plus lourds dans les tiroirs les plus bas.
- Ne désactivez pas et ne retirez pas le système de verrouillage du tiroir.

Ceci est une étiquette permanente.

Ne pas enlever!

WARNUNG



Kinder sind an einem Möbelkipp gestorben. So verringern Sie das Risiko eines Umkippens von Möbeln:

- Installieren Sie IMMER die mitgelieferte Kipprückhaltevorrichtung.
- Stellen Sie NIEMALS einen Fernseher an dieses Produkt.
- Lassen Sie Kinder NIEMALS an Schubladen, Türen oder Regalen stehen klettern oder hängen.
- Öffnen Sie NIEMALS mehr als eine Schublade gleichzeitig.
- Legen Sie schwerste Gegenstände in die untersten Schubladen.
- Besiegen oder entfernen Sie das Schubladenverriegelungssystem nicht.

Dies ist ein dauerhaftes Etikett.

Nicht entfernen!