

# Side Table

Assembly Guide

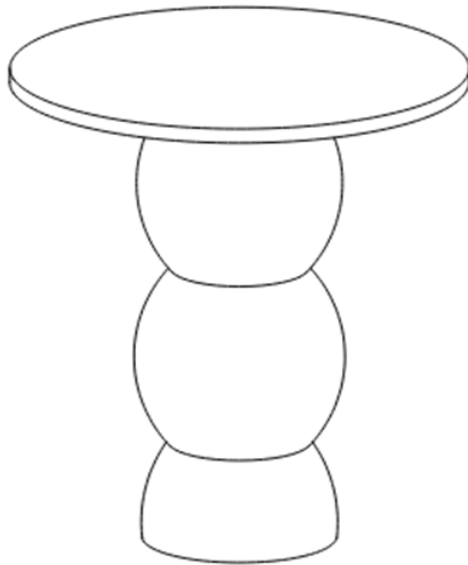

**IMPORTANT:** please read these instructions fully before starting assembly



**SAFETY AND  
CARE ADVICE**



**NO POWER TOOLS**

- Check you have all the components and tools listed
- Remove all fittings from their bags and separate into groups
- We do not recommend use of power tools - this could damage the unit. Only use hand screwdrivers and Allen keys
- Keep children and animals away from the work area, small parts could cause choking if swallowed
- Make sure you have enough space to lay out the parts before starting
- Assemble the item as close to its final position (same room) as possible
- Do not over tighten the nuts to avoid damage to the threads
- Only clean using a damp cloth and mild detergent. Do not use bleach or abrasive cleaners
- From time to time, check there are no loose screws in this unit
- This product should not be discarded with household waste. Take to your local authority waste disposal centre
- Unless otherwise stated, this product is designed for domestic use and is not certified for commercial or contract settings.

## IMPORTANT INFORMATION



15 Minute  
Build



Two Person  
Build







Max Weight  
Capacity  
30kg / 66lbs

**Note:** Assembly estimates are approximate and can differ based on the specific environment and user experience.

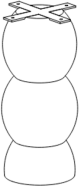
## WHAT'S IN THE BOX

**Note:** the quantities are the correct amount to complete the assembly. In some cases more fixings may be supplied than are required.

| Label | Part Name | Drawing   | Quantity |
|-------|-----------|---|----------|
| A     | Top       |  | 1        |
| B     | Base      |  | 1        |

| Label | Hardware Description | Drawing   | Size (mm) | Quantity |
|-------|----------------------|---|-----------|----------|
| H1    | Washer               |  | 25        | 4        |
| H2    | Allen Bolt           |  | 13x6x15   | 4        |
| H3    | Allen Key            |  | 4         | 1        |

Note:

- Use a clear, flat surface to avoid bumps or scratches before assembling.
- Insert all fixings loosely at first to allow for alignment; only tighten them once everything is properly positioned, as some adjustment may be required.
- Avoid over-tightening, as this may damage the parts.
- Seek assistance when moving large or heavy parts

## STEP 1

Place Table top [A] upside down on a flat surface.

Align the brackets on the table base [B] with the pre drilled holes on the underside of the table top [A]

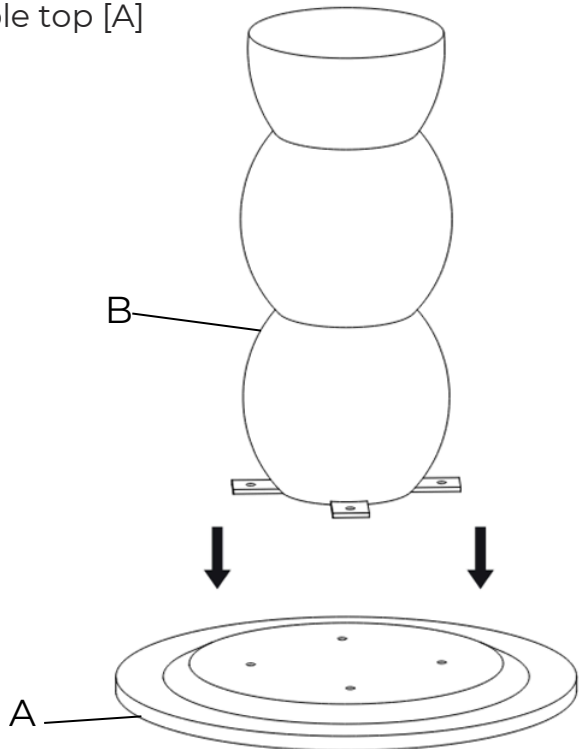

## STEP 2

Secure the table base [B] to the top [A] using 4x washer [H1] and 4x bolts [H2] and tighten using Allen key [H3].

**NOTE:** Do not overtighten the bolts to avoid damaging the wooden surface.

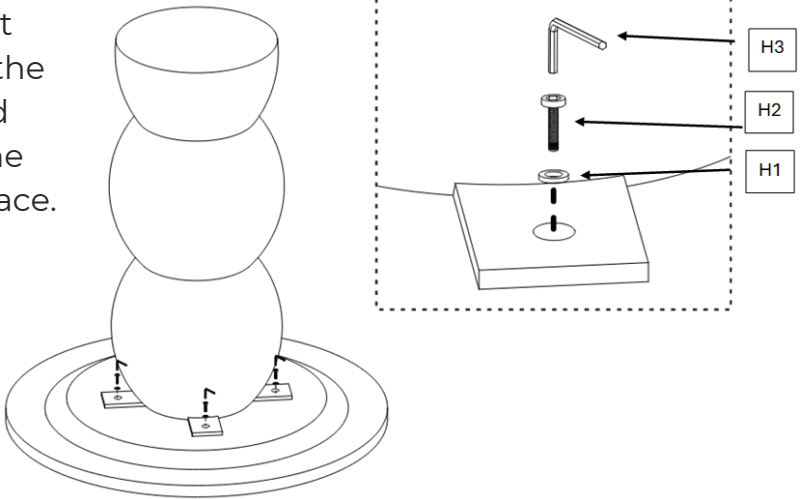

## STEP 3

Carefully, flip the table to stand on its legs.

Check stability.

Your Side table is now ready to use!

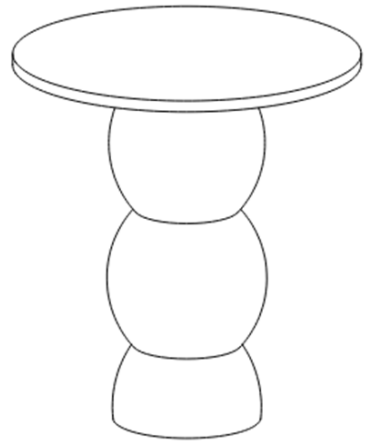

**Please ensure any and all fixings and fittings are FULLY tightened before using this product**



# our 2 year GUARANTEE

Our products come with a 2 year guarantee, giving you extra peace of mind when shopping with us!

## *What the guarantee covers*



**PRE-INSERTED FIXINGS**  
e.g. loose metal threads



**FAULTY JOINTS**  
e.g. legs bending



**EXTERNAL FIXING FAULTS**  
e.g. metal discs removing  
from table top



**STRUCTURAL INTEGRITY**  
e.g. the frame of the  
product

---