

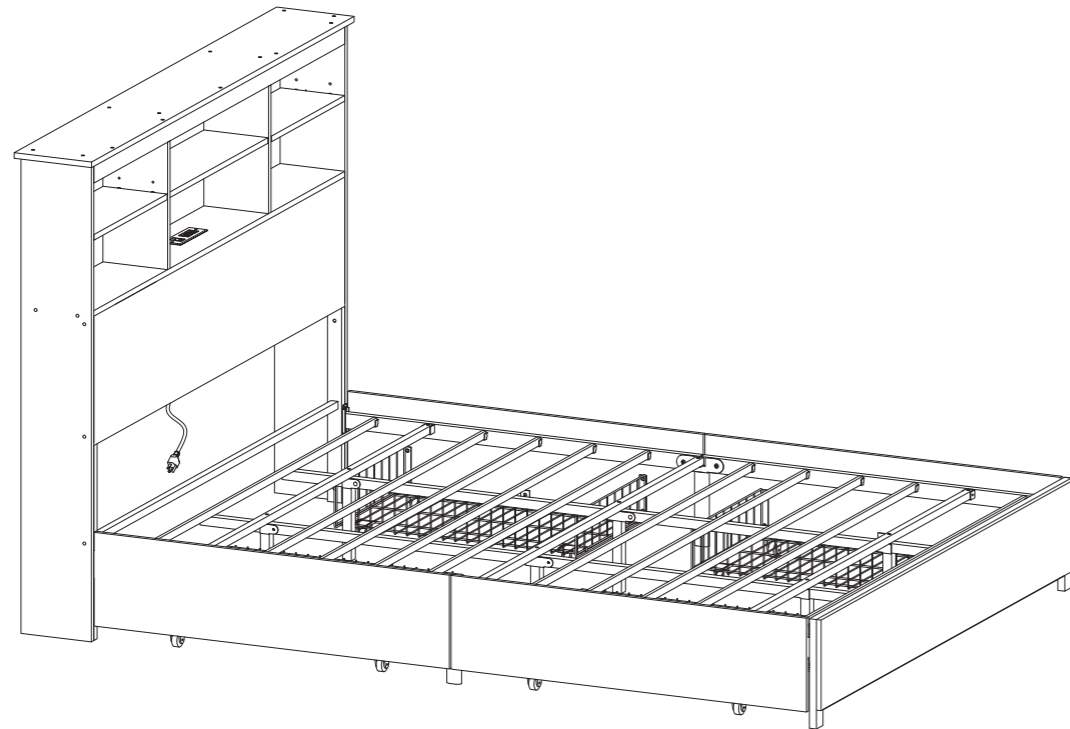

SKU:KHD-K51-BRN

Lot No.:YJX-NO.1



Assembly Guide

Tip!

Do check for all the components and screws listed in this guide before putting things together. If any part is missing, contact us at support@vecelo.com (US / CA) or support-euteam@vecelo.com (EU) for the missing part.

Return Policy

Your satisfaction is our top priority. If our product fails to satisfy you, please let us know how we can make things right for you. Our trained customer care team can handle most concerns and assist you with any questions you may have. Simply shoot them a message at support@vecelo.com(US/CA) or support-euteam@vecelo.com(EU) with your order number and question. To be eligible for a full-refund return, the item must be in pristine condition, in the original packaging, with all of the shipped components intact and not yet assembled, and with the item's unique proof of purchase.

Trouble shooting:

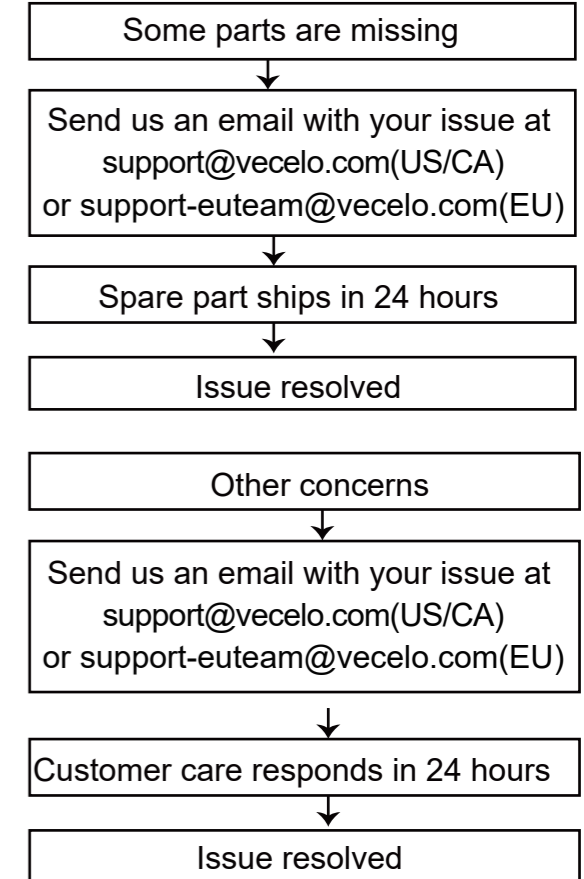

We run our own manufacturer, so rest assured about the quality consistency.

CONTACT US

KONTAKTIEREN SIE UNS

NOUS CONTACTER

CONTATTACI

CONTACTÉNOS

E-mail: support@vecelo.com (US/CA)

E-mail: support-euteam@vecelo.com (EU/FR/DE/ES/IT)

Website: www.vecelo.com

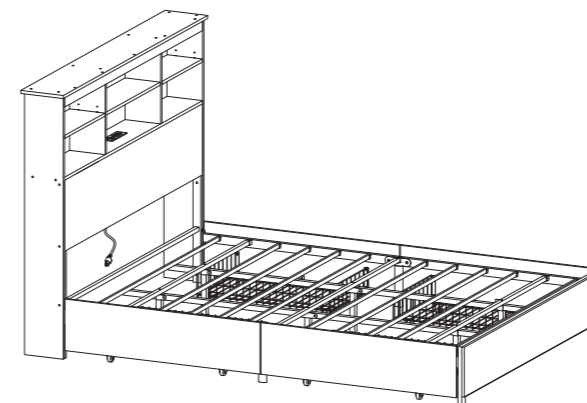

Item Description: Bed Frame

Model NO: YJX-NO.1

Ships and arrive in TWO boxes and delivery time may vary per box.

Montageanleitung

Tipp!

ÜBERPRÜFEN Sie alle in dieser Anleitung aufgeführten Komponenten und Schrauben, bevor Sie die Bauteile zusammenbauen. Sollte ein Bauteil fehlen, kontaktieren Sie uns unter support-euteam@vecelo.com um Ersatz zu erhalten.

Rückgaberrichtlinie

Ihre Zufriedenheit ist unsere oberste Priorität. Wenn Sie mit unserem Produkt nicht zufrieden sind, lassen Sie uns bitte wissen, wie wir die Angelegenheit für Sie in Ordnung bringen können. Unser geschultes Kundenbetreu kann die meisten Anliegen lösen und unter Sie bei allen Ihren Fragen. Senden Sie uns einfach eine Nachricht an support-euteam@vecelo.com mit Ihrer Bestellnummer und Ihrer Frage. Um eine volle Rückerstattung zu erhalten, muss der Artikel in einwandfreiem Zustand sein und sich in der Originalverpackung mit allen gelieferten und noch nicht zusammengebaute Komponenten befinden. Zudem wird der eindeutige Kaufnachweis des Artikels.

Problemlösung:

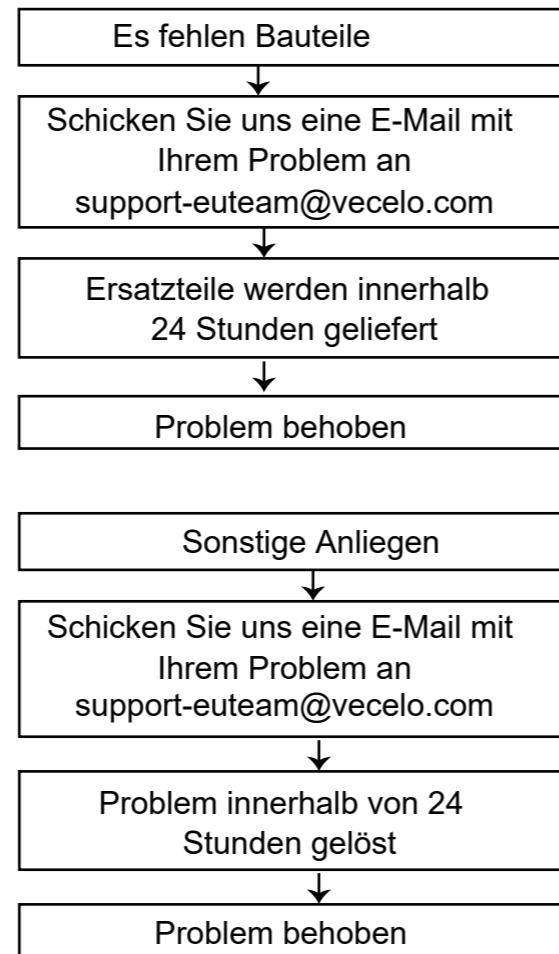

Wir stellen unsere Artikel selbst her, sodass Sie sich auf gleichbleibende Qualität verlassen können.

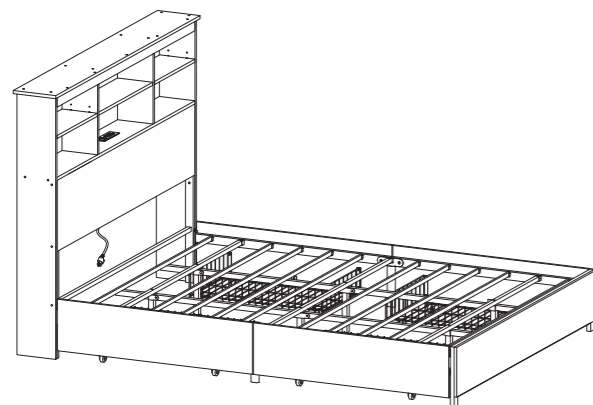

Item Description: Bettrahmen

Model NO: YJX-NO.1

CAUTION!



ACHTUNG!

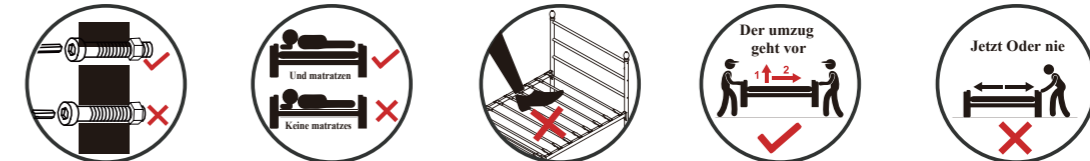

ATTENTION!



CAUTELA!



PRECAUCIÓN!



Versand und Ankunft in ZWEI Boxen und die Lieferzeit kann je nach Box variieren.

Step 24

- Carefully lift the drawer as you push it in.
Please align the screw with the hole on the iron pipe and hang it up
- ★ Heben Sie die Schublade vorsichtig an, während Sie sie hineindrücken.
Bitte richten Sie die Schraube am Loch am Eisenrohr aus und hängen Sie sie auf
- ▲ Soulevez soigneusement le tiroir tout en le poussant.
Alignez soigneusement la vis avec le trou sur le tuyau en fer et suspendez-le.
- Solleva con attenzione il cassetto mentre lo spingi dentro.
Allinea la vite con il foro sul tubo di ferro e appendilo.
- ✱ Levante con cuidado el cajón mientras lo empuja hacia adentro.
Alinee el tornillo con el orificio del tubo de hierro y cuélguelo.

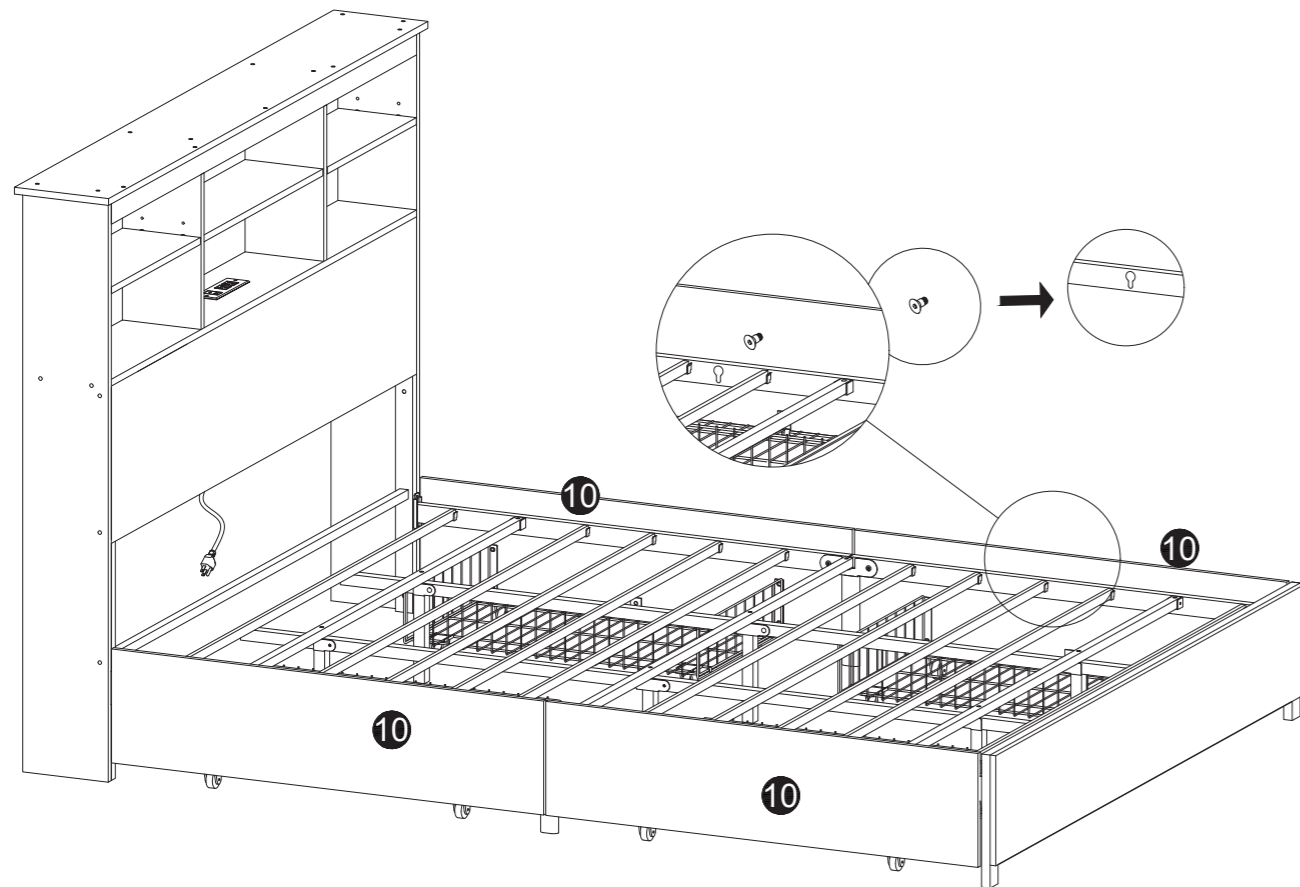

Guide de montage

Attention !

VÉRIFIEZ la présence de l'ensemble des éléments et vis énumérés dans ce guide avant de procéder au montage. Si une pièce venait à manquer, envoyez-nous un e-mail à support-euteam@vecelo.com pour nous le signaler.

Politique de retour

Votre satisfaction est notre priorité absolue. Si notre produit ne vous donne pas entière satisfaction, n'hésitez pas à nous faire savoir ce que nous pouvons faire pour améliorer la situation. Notre équipe d'assistance à la clientèle qualifiée est en mesure de résoudre la plupart de vos problèmes et de répondre à toutes vos questions. Il vous suffit de leur envoyer un message à l'adresse support-euteam@vecelo.com en indiquant votre numéro de commande et votre question. Pour pouvoir bénéficier d'un remboursement intégral, l'article doit être en parfait état, dans son emballage d'origine, avec tous les composants expédiés intacts et non encore assemblés, et avec la preuve d'achat unique de l'article.

SKU:KHD-K51-BRN

Lot No.:YJX-NO.1

Dépannage :

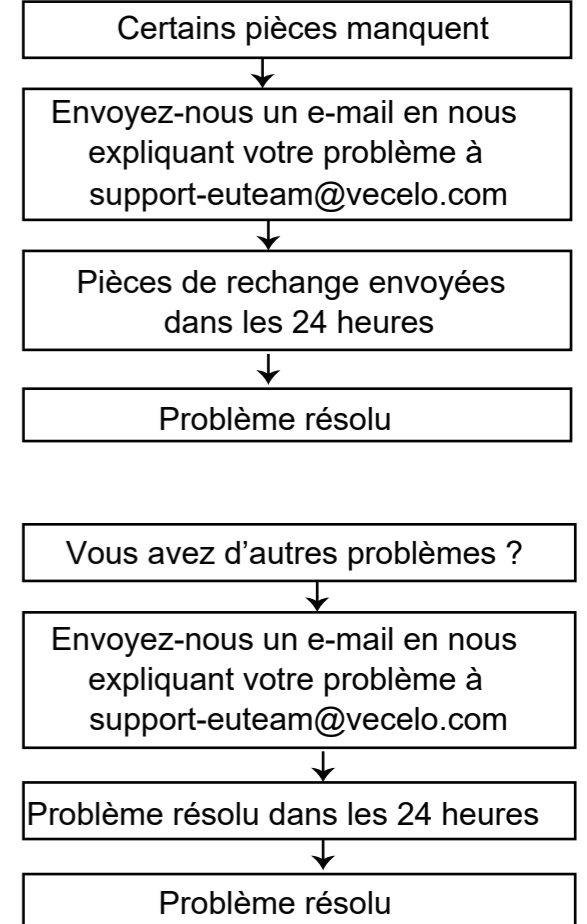

Nous assurons notre propre fabrication, donc soyez assuré de bénéficier d'une qualité constante.

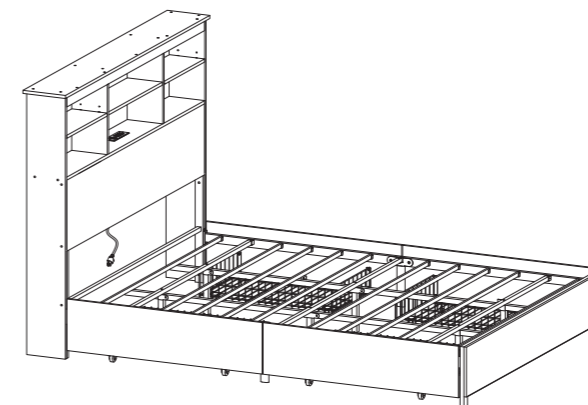

Item Description: Cadre de lit

Model NO: YJX-NO.1

Les colis arrivent en DEUX boîtes avec des délais de livraison variables pour chacune.

Guida all'assemblaggio

Mancia!

Controllare tutti i componenti e le viti elencati in questa guida prima di inserire le cose insieme. Se manca qualche parte, contattaci a support-euteam@vecelo.com per i dispersi parte.

Politica di ritorno

La vostra soddisfazione è la nostra massima priorità. Se il nostro il prodotto non ti soddisfa, faccelo sapere come possiamo sistemare le cose per te. Nostro un team di assistenza clienti qualificato può gestire la maggior parte preoccupazioni e assistervi per qualsiasi domanda tu forse hai. Invia loro semplicemente un messaggio a support-euteam@vecelo.com con il tuo numero d'ordine e domanda. Essere eleggibile per un reso con rimborso completo, l'articolo deve essere presente ottime condizioni, nella confezione originale, con tutti i componenti spediti intatti e non ancora assemblato e con l'oggetto unico prova d'acquisto.

SKU:KHD-K51-BRN

Lot No.:YJX-NO.1

Risoluzione dei problemi:

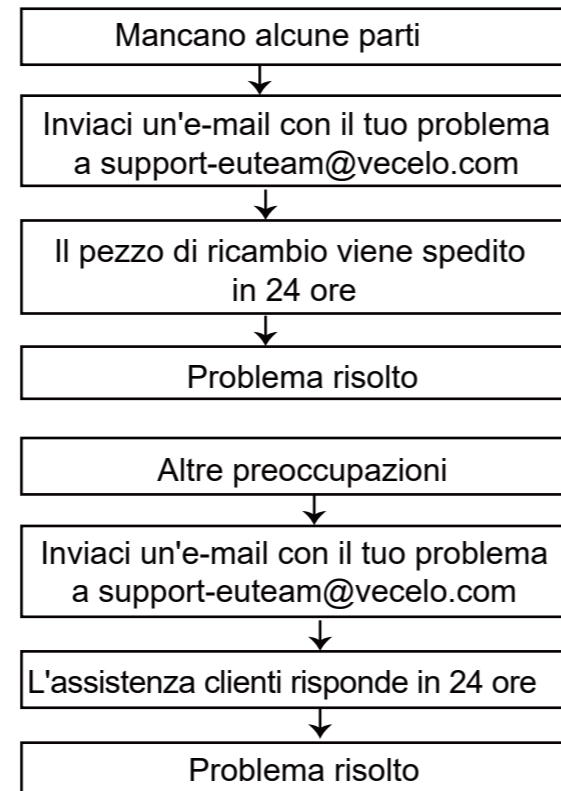

Gestiamo il nostro produttore, quindi riposati assicurato circa la consistenza di qualità.

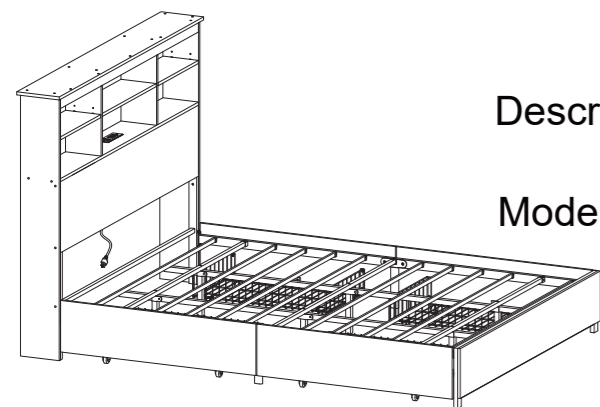

Descrizione dell'articolo: Telaio del letto

Modello NO: YJX-NO.1

Per la spedizione e l'arrivo sono necessarie due scatole, i tempi di spedizione possono variare per ogni scatola.

Step 23

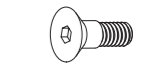

M8x24mm

H x 4pcs

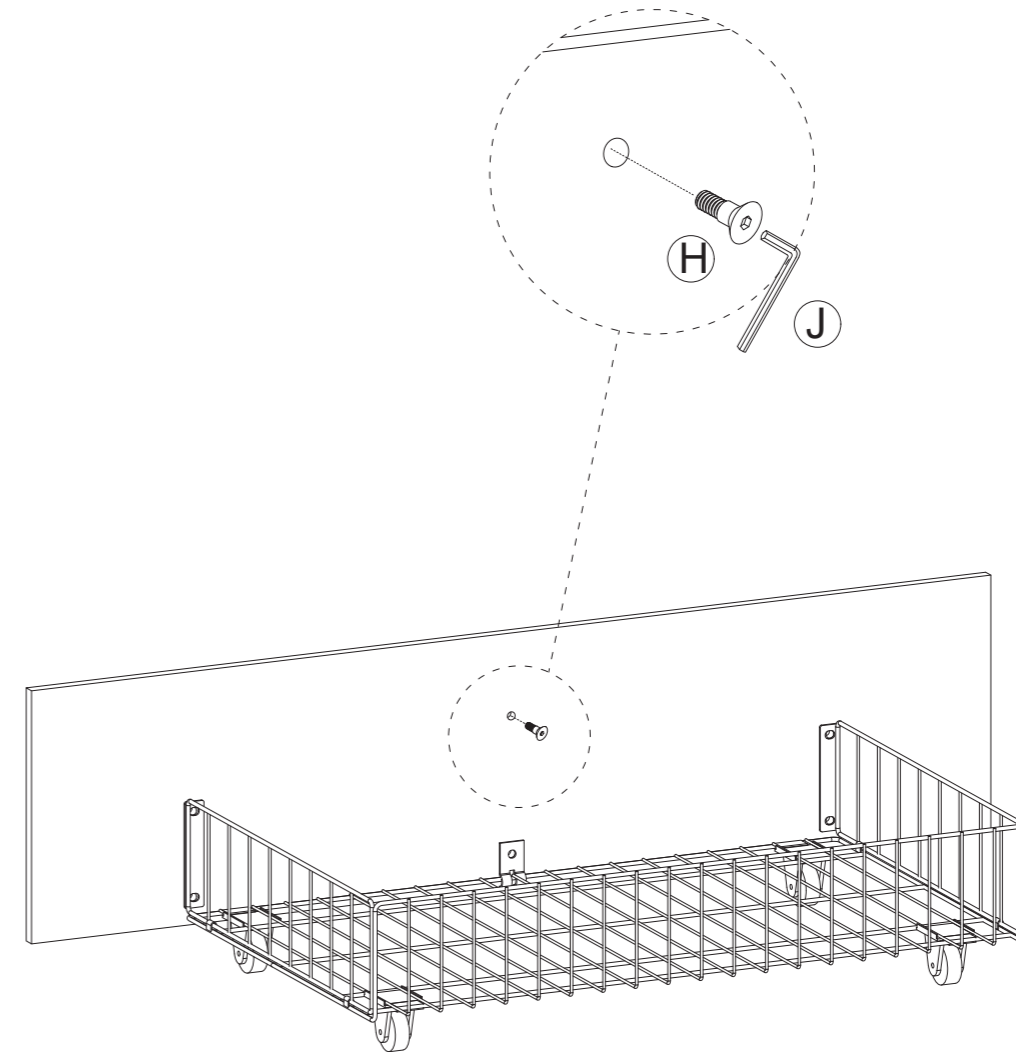

x4

Step 21

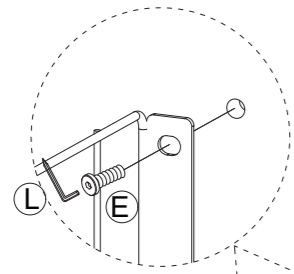

M6×10mm
E × 20pcs

O × 4pcs

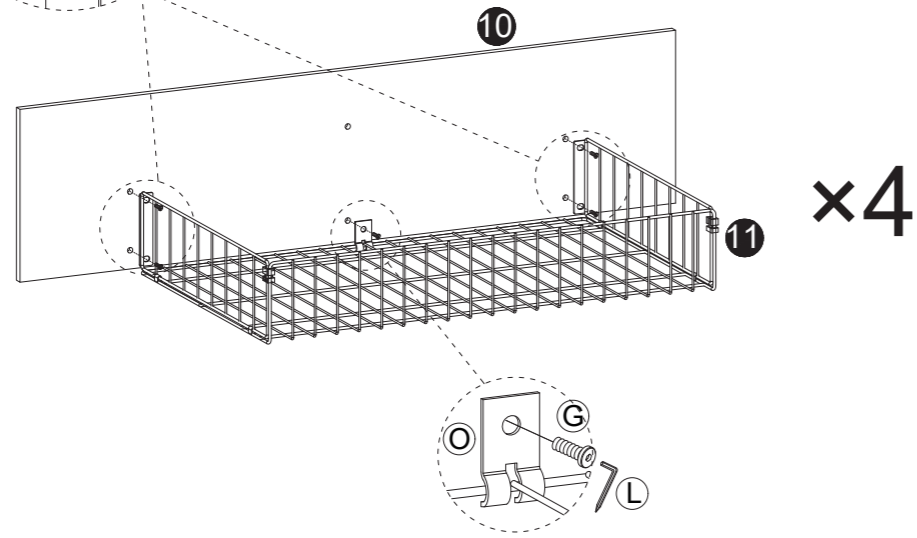

Step 22

- Clamp the wire with the opening of the front end of the wheel and press down to tighten the wire.
- ★ Klemmen Sie den Draht mit der Öffnung des vorderen Endes des Rades und drücken Sie ihn nach unten, um den Draht festzuziehen.
- ▲ Pincez le fil avec l'ouverture de l'extrémité avant de la roue et appuyez pour serrer le fil.
- Bloccare il filo con l'apertura dell'estremità anteriore della ruota e premere verso il basso per tendere il filo.
- ✱ Sujete el cable con la abertura del extremo delantero de la rueda y presione hacia abajo para apretar el cable.

S × 16pcs

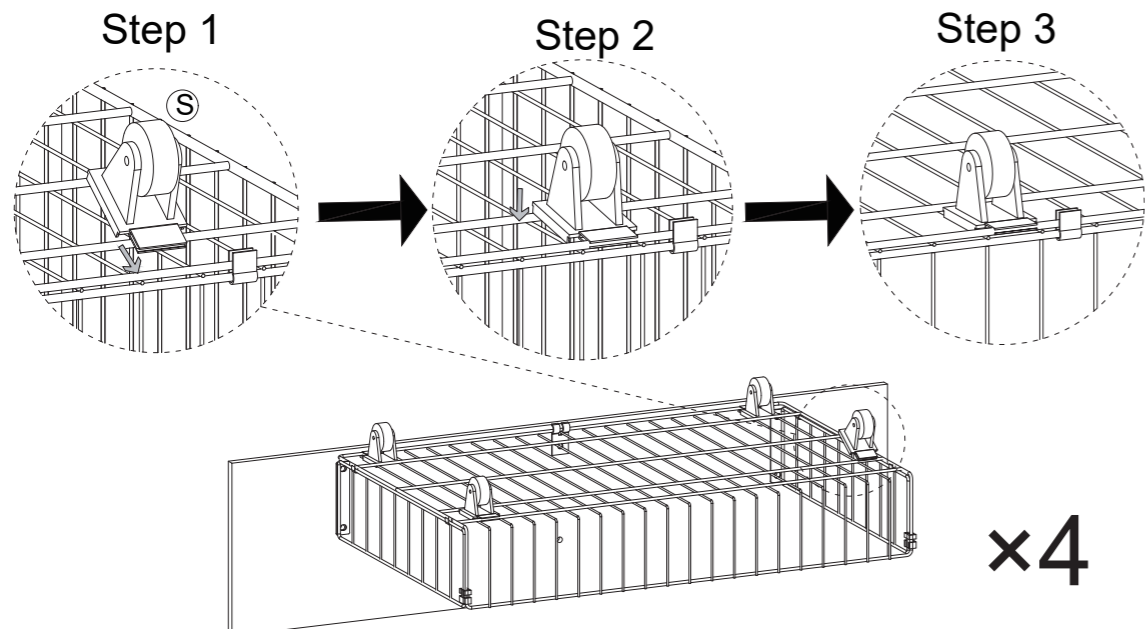

Guía de montaje

Consejo!

Verifique todos los componentes y tornillos. Enumerados en esta guía antes de poner las cosas juntos. Si falta alguna pieza, contáctanos al support-euteam@vecelo.com por los desaparecidos parte.

Política de devoluciones

Su satisfacción es nuestra máxima prioridad. Si nuestro el producto no le satisface, háganoslo saber. CÓMO podemos hacer las cosas bien para usted. Nuestro equipo de atención al cliente capacitado puede manejar la mayoría inquietudes y ayudarle con cualquier pregunta es posible que tengas. Simplemente envíales un mensaje en support-euteam@vecelo.com con su número de pedido y pregunta. Ser elegible para una devolución con reembolso completo, el artículo debe estar en impecable estado, en el embalaje original, con todos los componentes enviados intactos y aún no ensamblado y con la característica única del artículo. Comprobante de compra.

SKU:KHD-K51-BRN

Lot No.:YJX-NO.1

Solución de problemas:

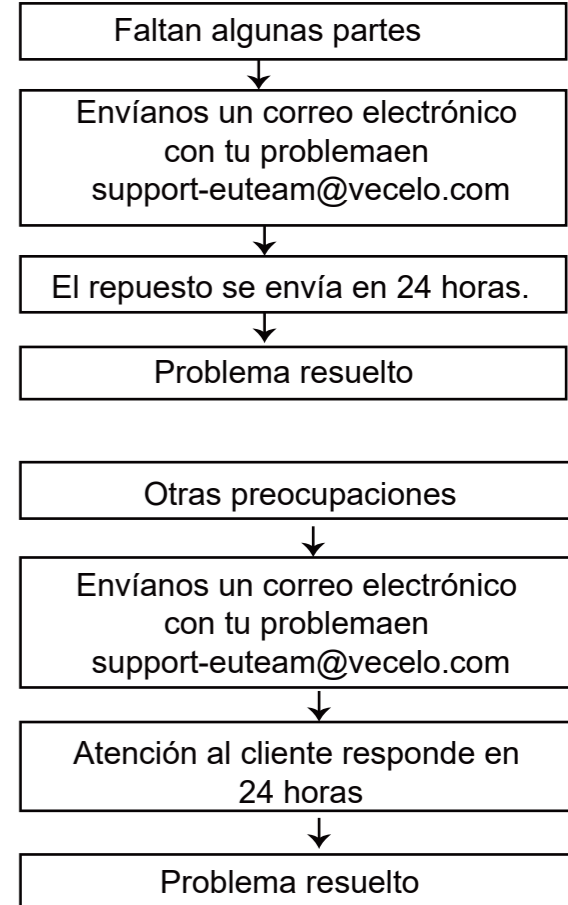

Dirigimos nuestro propio fabricante, así que descansa. Asegurado sobre la consistencia de la calidad

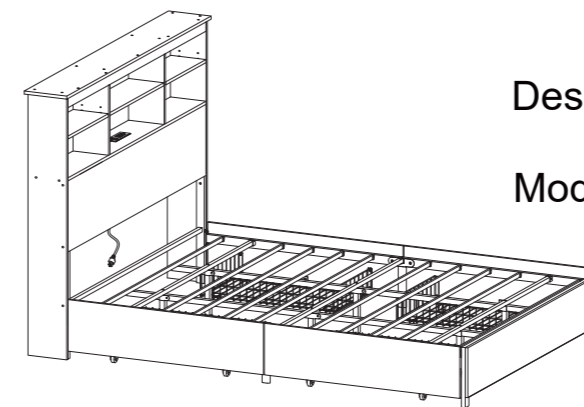

Descripción del artículo: Marco de la cama

Modelo NO: YJX-NO.1

Se envía y llega en DOS cajas y el tiempo de entrega puede variar según la caja.

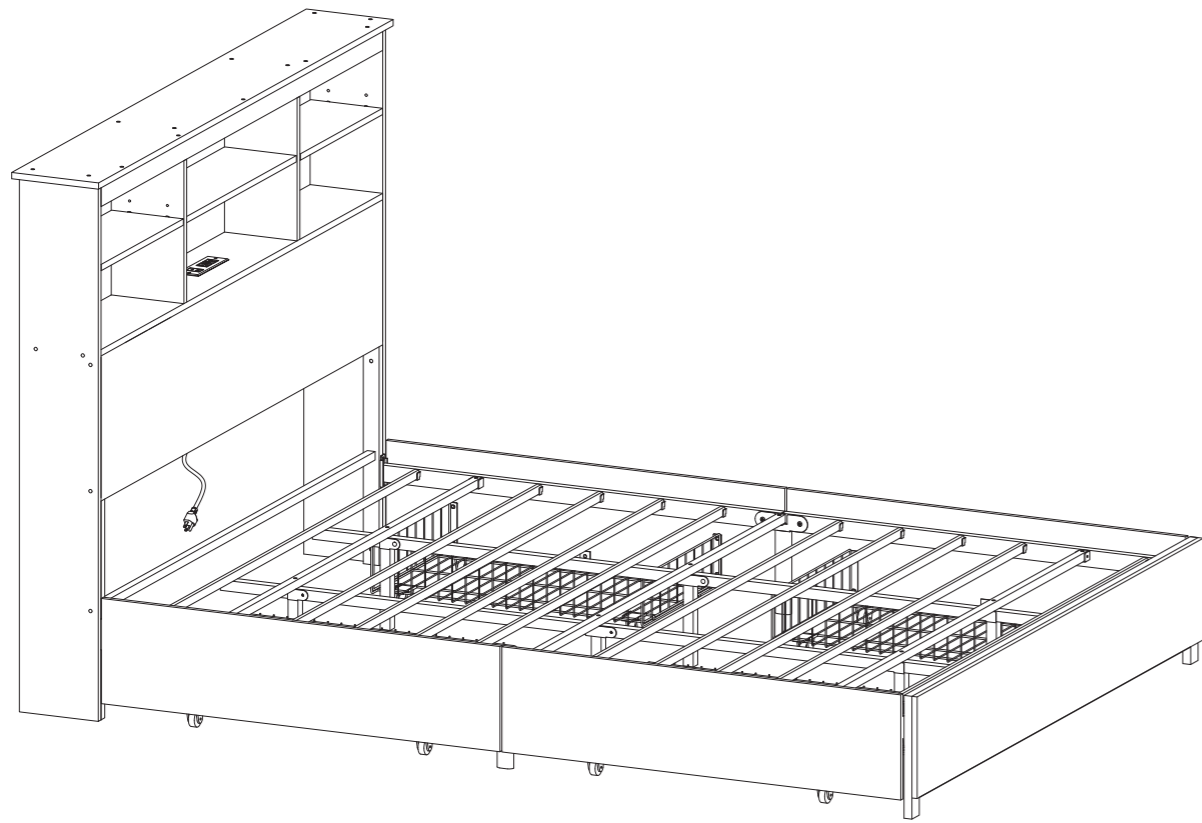

Step 19

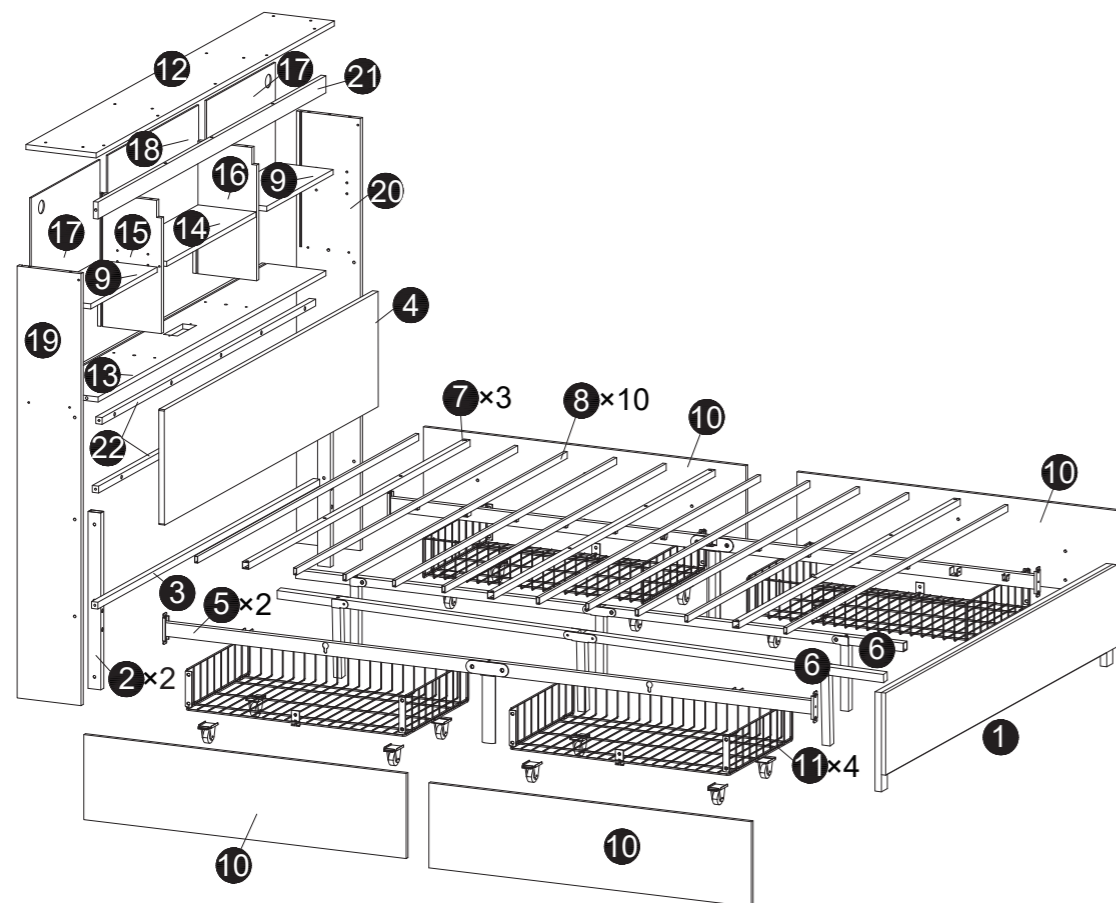
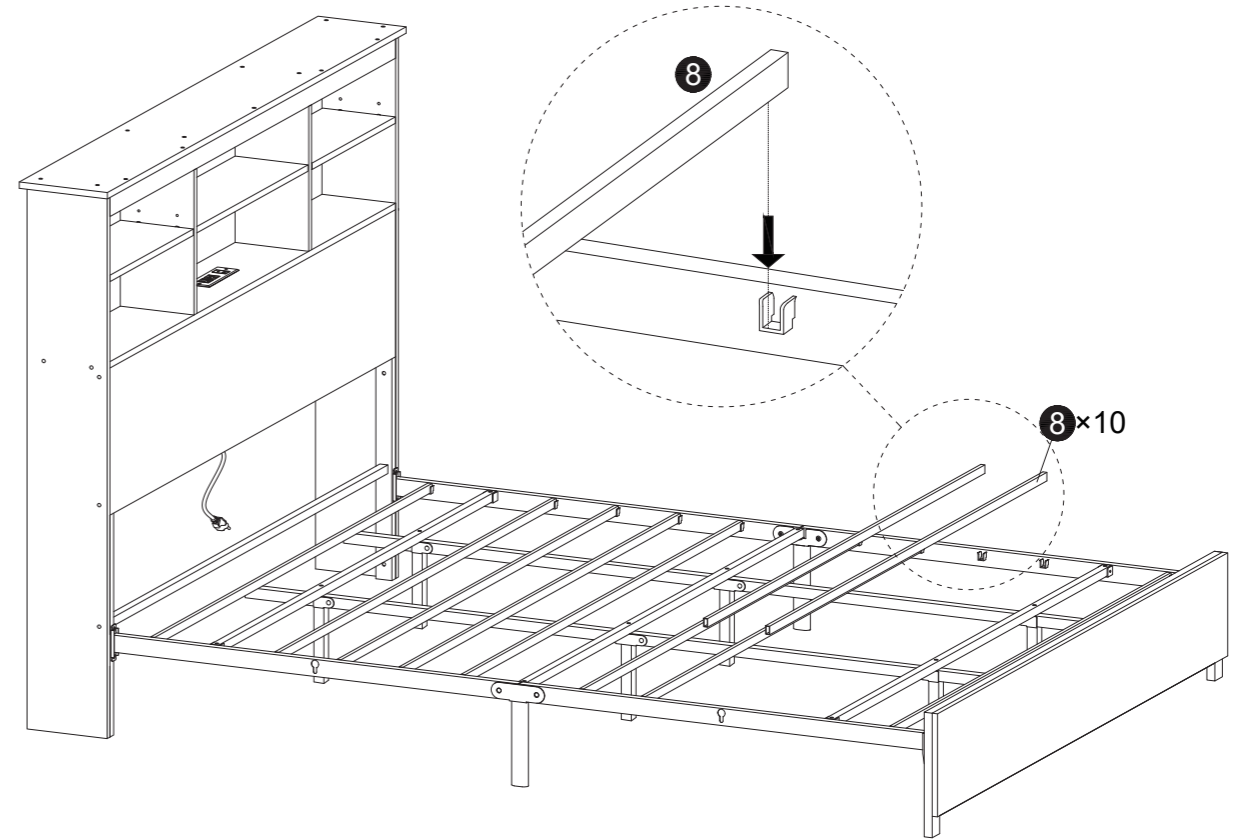

Step 20

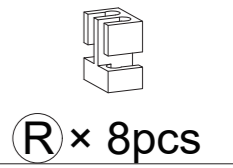

- Disconnect it a little and clamp the fastener
- ★ Trennen Sie es ein wenig und klemmen Sie das Befestigungselement fest
- ▲ Déconnectez-le légèrement et pincez le dispositif de fixation.
- Scollegatelo leggermente e fissate il dispositivo di fissaggio.
- ✱ Desconéctalo un poco y sujeta el sujetador.

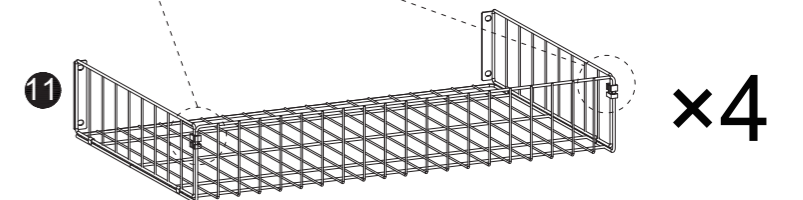
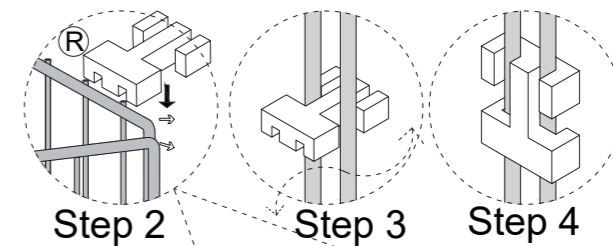
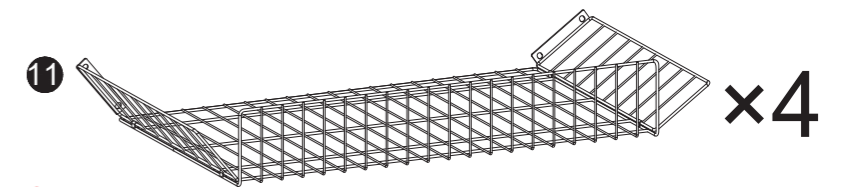

Step 18

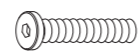

M6×55mm

B × 6pcs

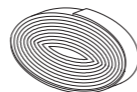

N × 2pcs



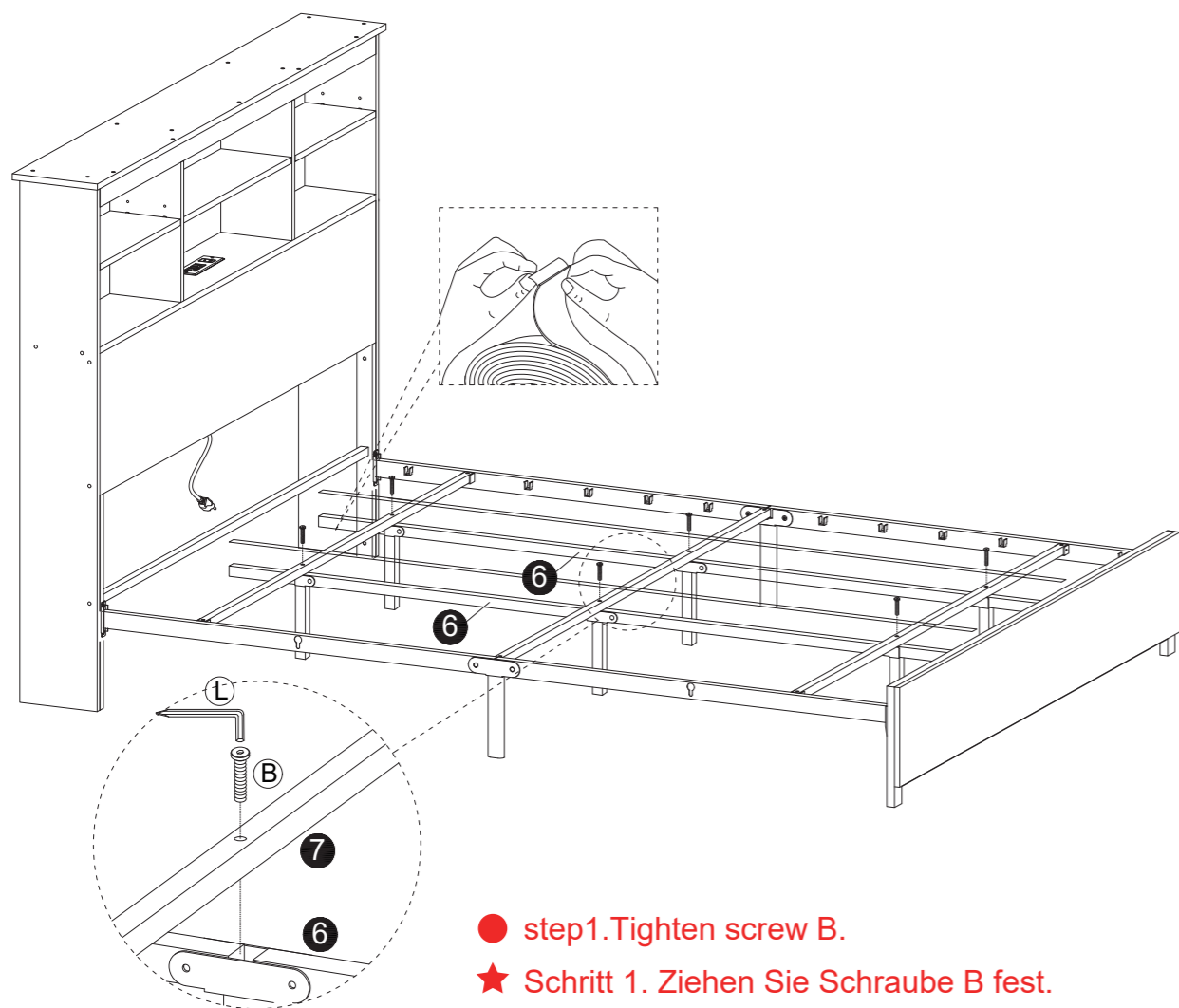









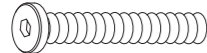

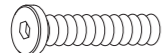
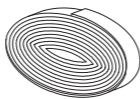
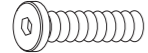
- step2.To prevent friction noise,unroll part N and fit it on part 6 , the lenght of part N can cut as you will.
- ★ Schritt 2. Um Reibungsgeräusche zu vermeiden, rollen Sie Teil N ab und montieren Sie es auf Teil 6, die Länge von Teil N kann nach Belieben geschnitten werden.
- ▲ Étape 2 : Pour éviter les bruits de friction, déroulez la pièce N et ajustez-la sur la pièce 6. La longueur de la pièce N peut être coupée comme vous le souhaitez.
- passaggio 2. Per evitare rumori di attrito, srotolare la parte N e montarla sulla parte 6, la lunghezza della parte N può essere tagliata a piacimento.
- ✳ Paso 2. Para evitar el ruido de fricción, desenrolle la parte N y colóquela en la parte 6, la longitud de la parte N se puede cortar como desee.

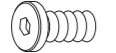

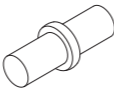
- step1.Tighten screw B.
- ★ Schritt 1. Ziehen Sie Schraube B fest.
- ▲ Étape 1 : Serrez la vis B.
- passaggio 1. Stringere la vite B.
- ✳ Paso 1. Apriete el tornillo B.

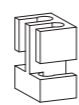
Components / Bauteile / Composants / Componenti / Componentes /

1		1pc	12		1pc
2		2pcs	13		1pc
3		1pc	14		1pc
4		1pc	15		1pc
5		2pcs	16		1pc
6		2pcs	17		2pcs
7		3pcs	18		1pc
8		10pcs	19		1pc
9		2pcs	20		1pc
10		4pcs	21		1pc
11		4pcs	22		2pcs

A	 M8×20mm	8pcs +1pc	J		1pc
B	 M6×55mm	8pcs +1pc	K	 Ø5×40mm	27pcs +1pc
C	 M6×40mm	4pcs +1pc	N		2pcs
D	 M6×30mm	20pcs +2pcs	O		4pcs +2pcs
E	 M6×10mm	20pcs +2pcs	P		1pc
F	 Ø3.5×12mm	2pcs +1pc	Q		8pcs +1pc
G		6pcs +1pc	R		8pcs +2pcs
H	 M8×24mm	4pcs +1pc	S		16pcs
I		1pc			

Step 17

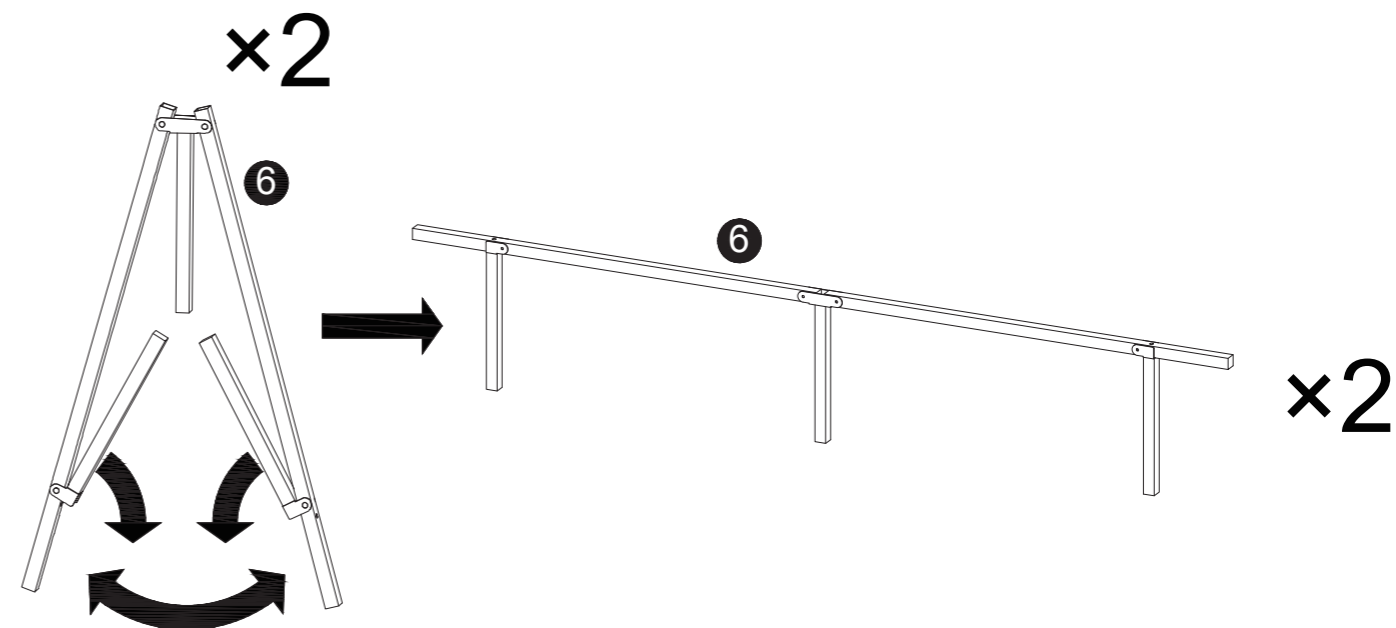

Step 15

M8×20mm
A × 4pcs

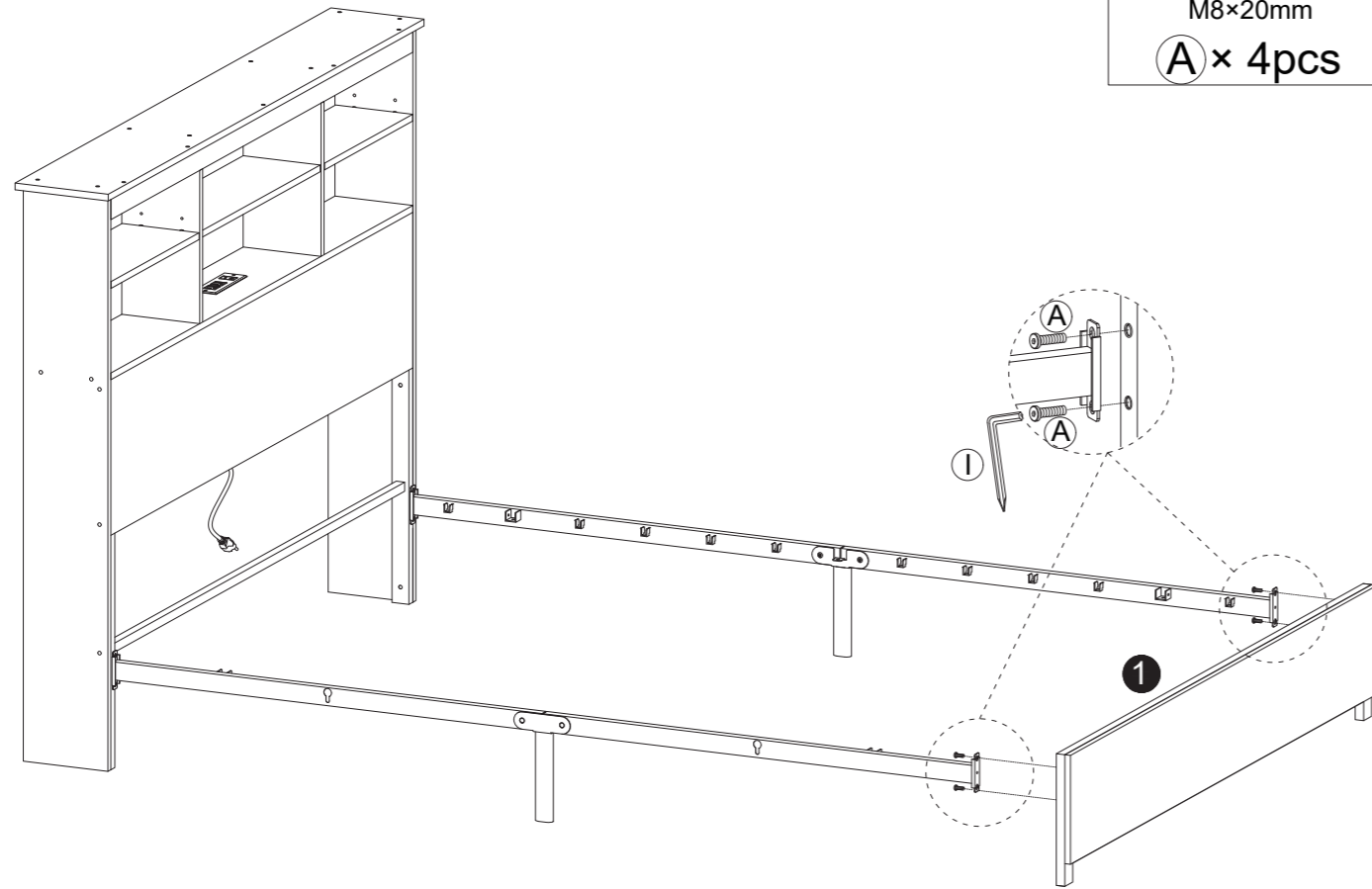

Step 1

Ø5×40mm
K × 4pcs

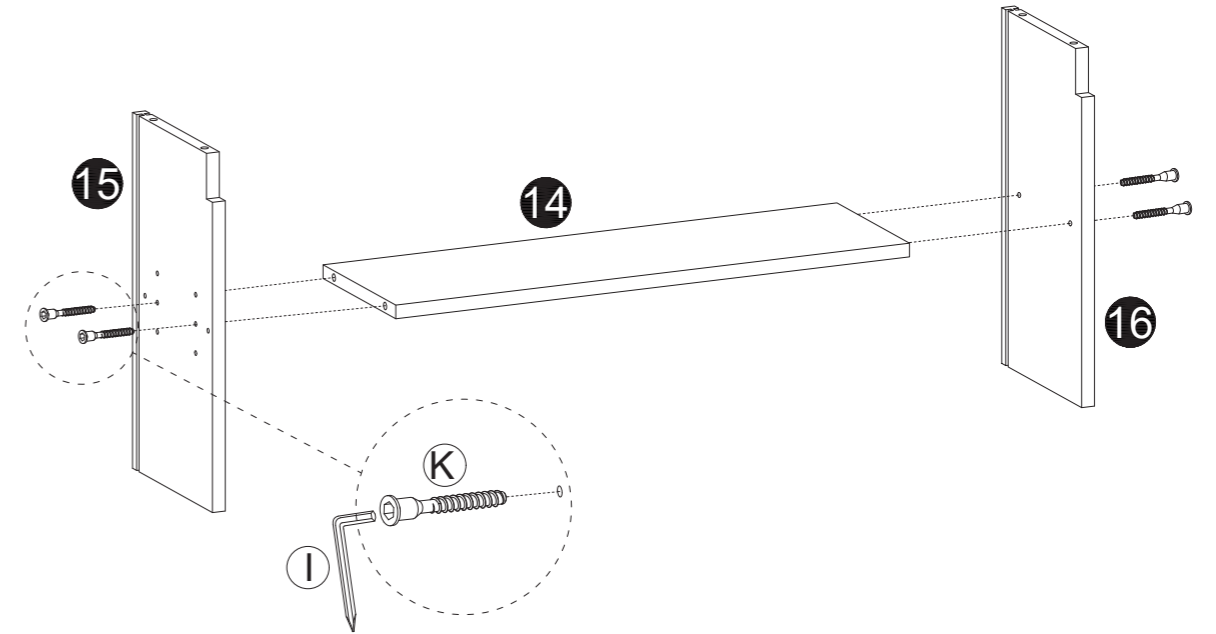



Step 16

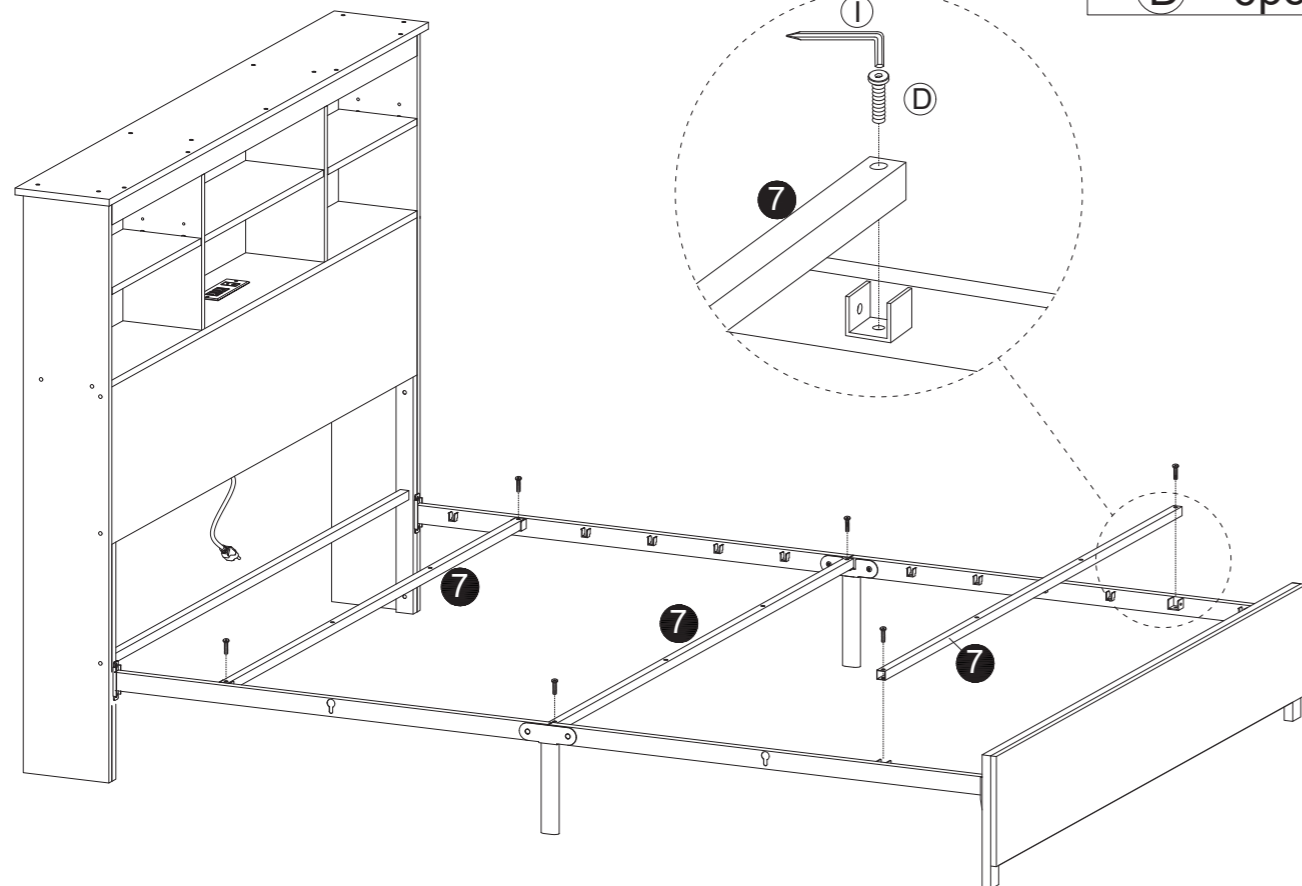

M6×30mm
D × 6pcs



Step 2

P × 1pc

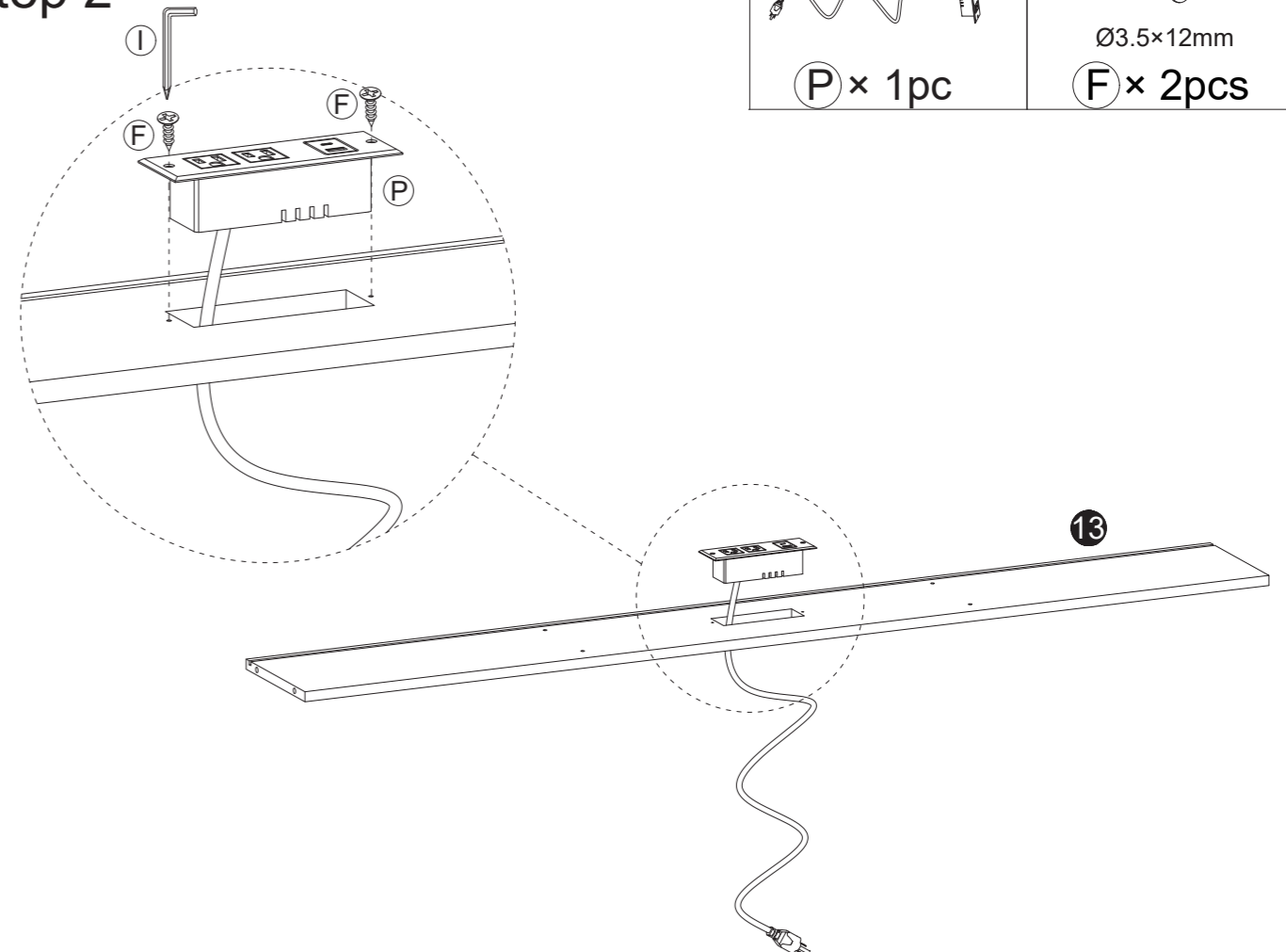

Ø3.5×12mm
F × 2pcs

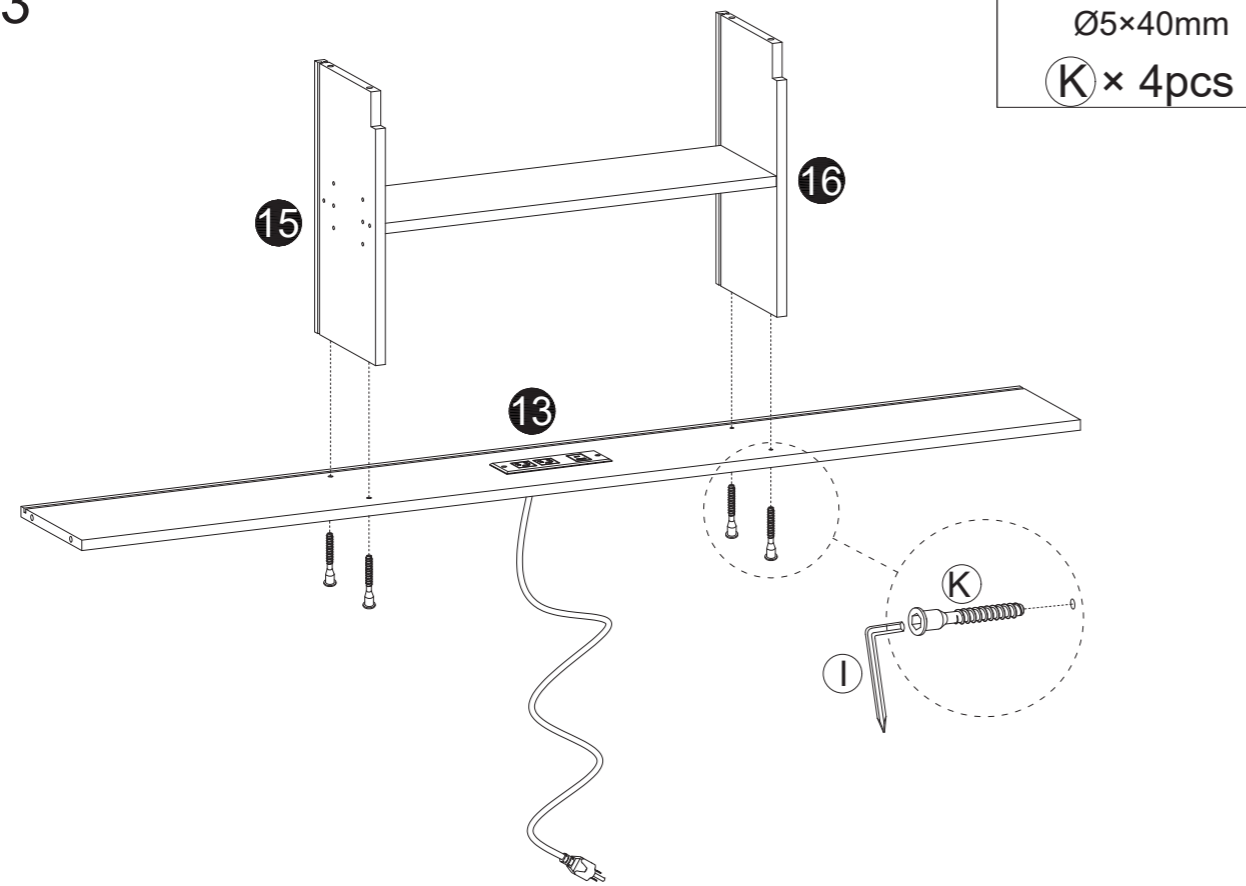

Step 3

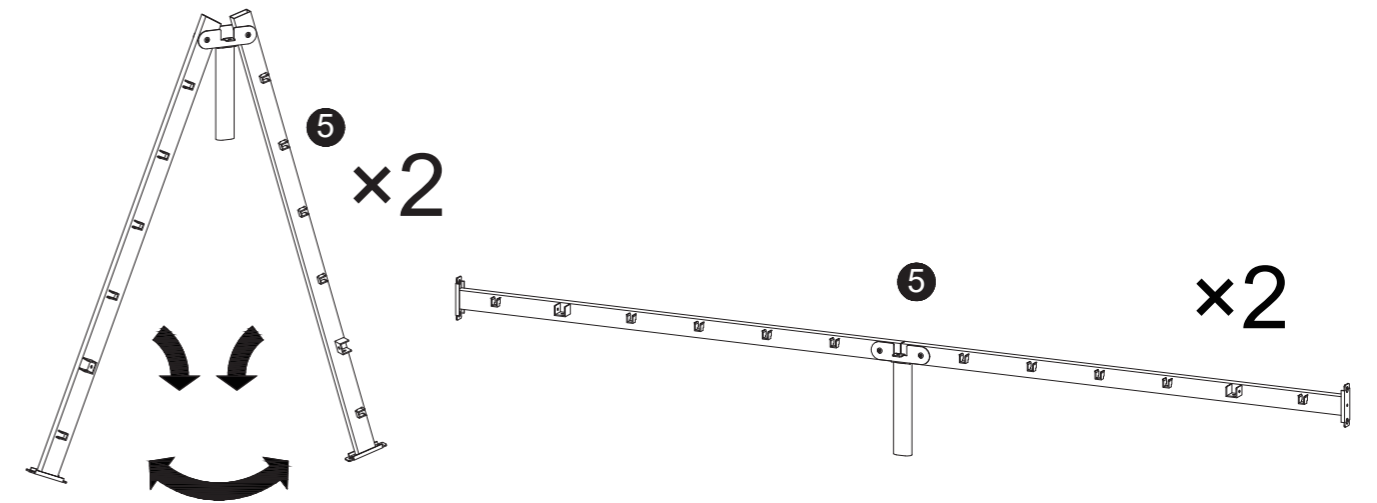

Step 13



Step 4

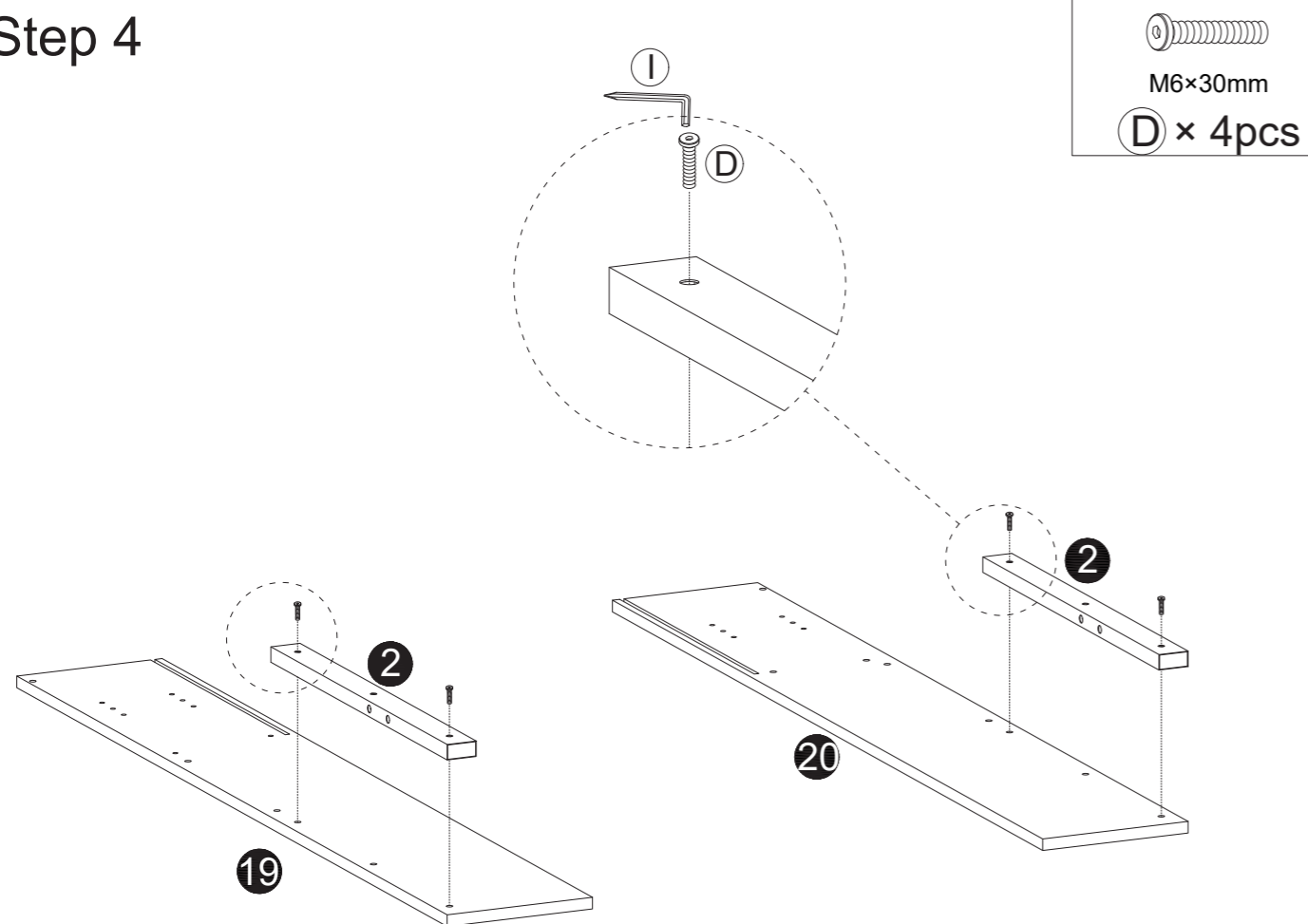

Step 14

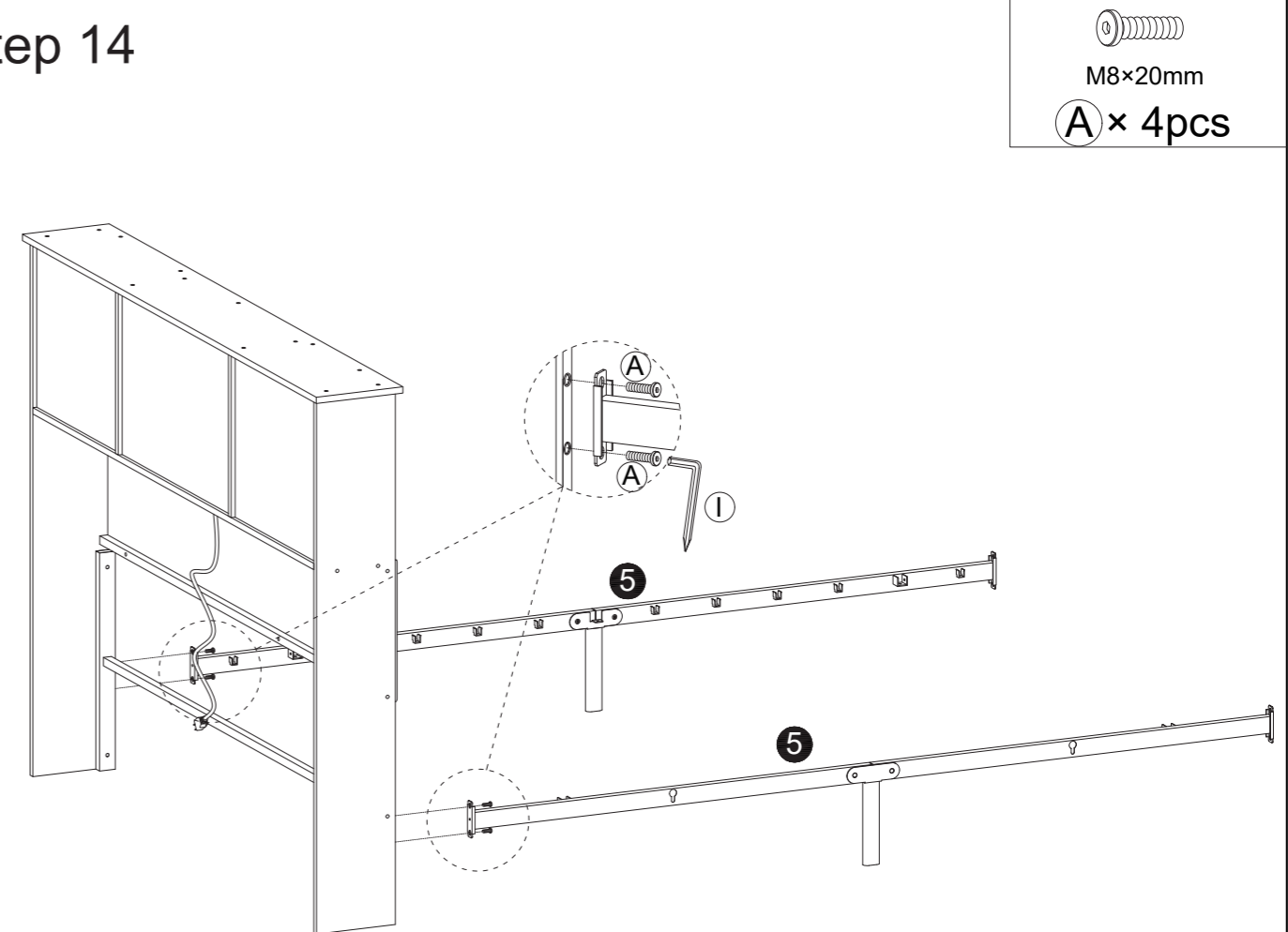

Step 11

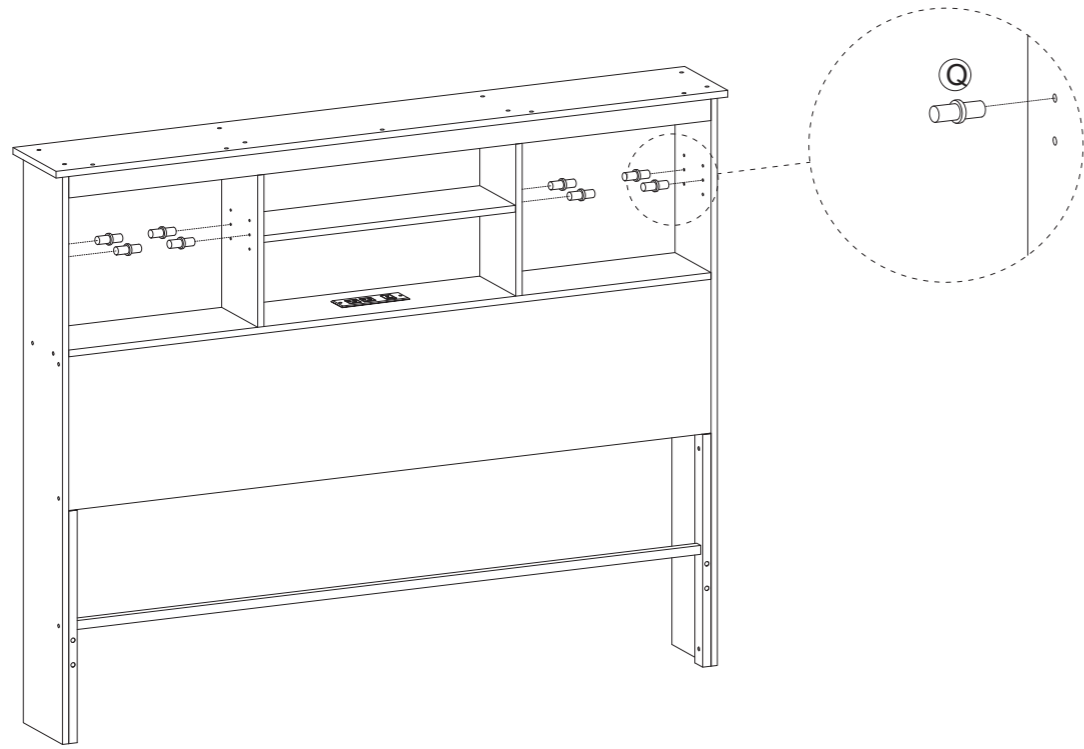
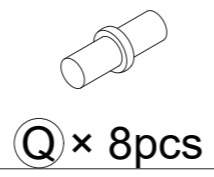

Step 12

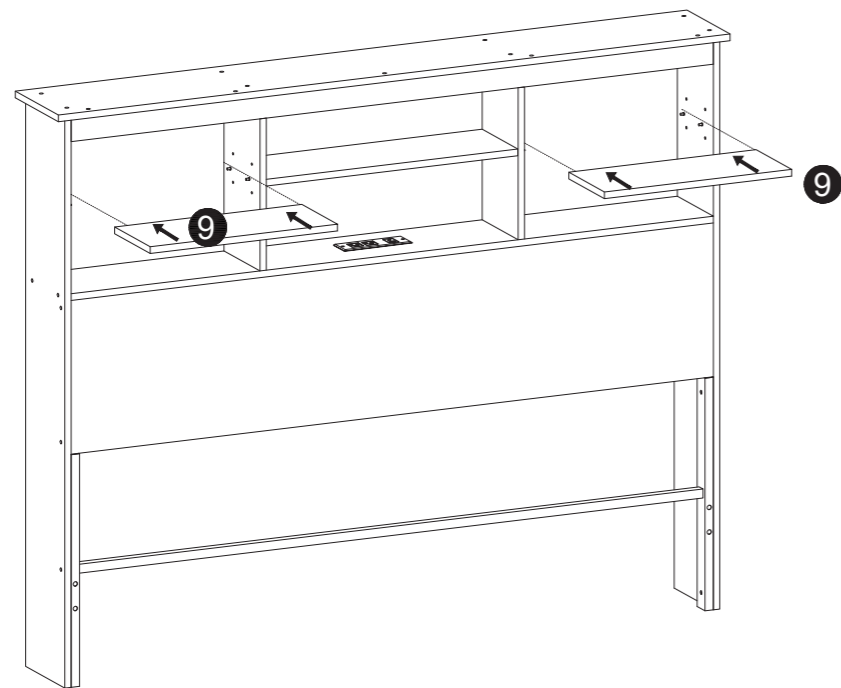

Step 5

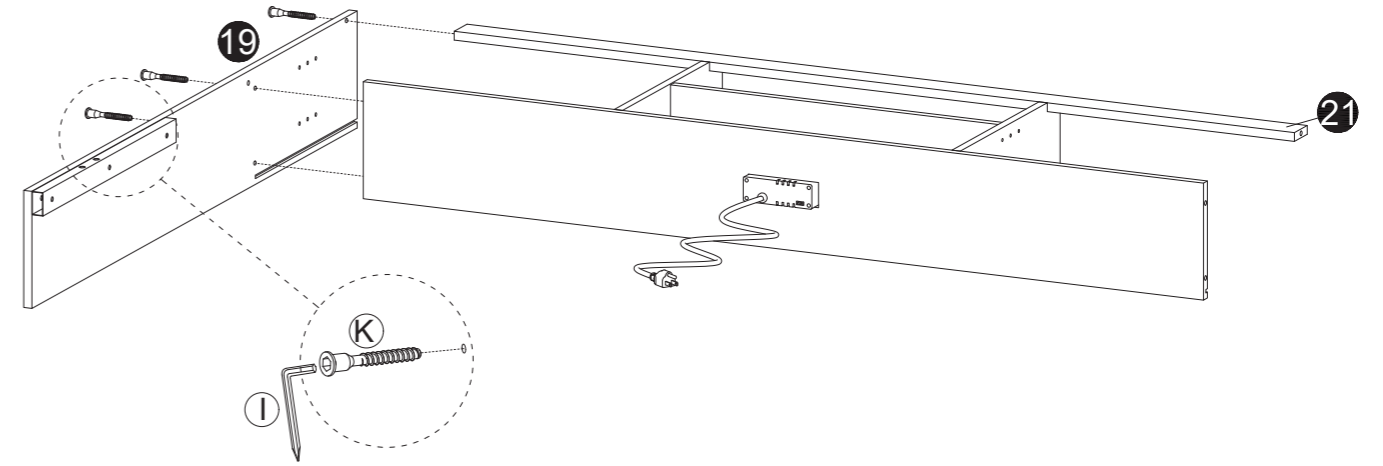
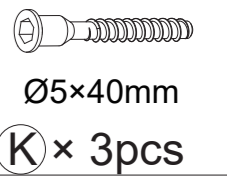

Step 6

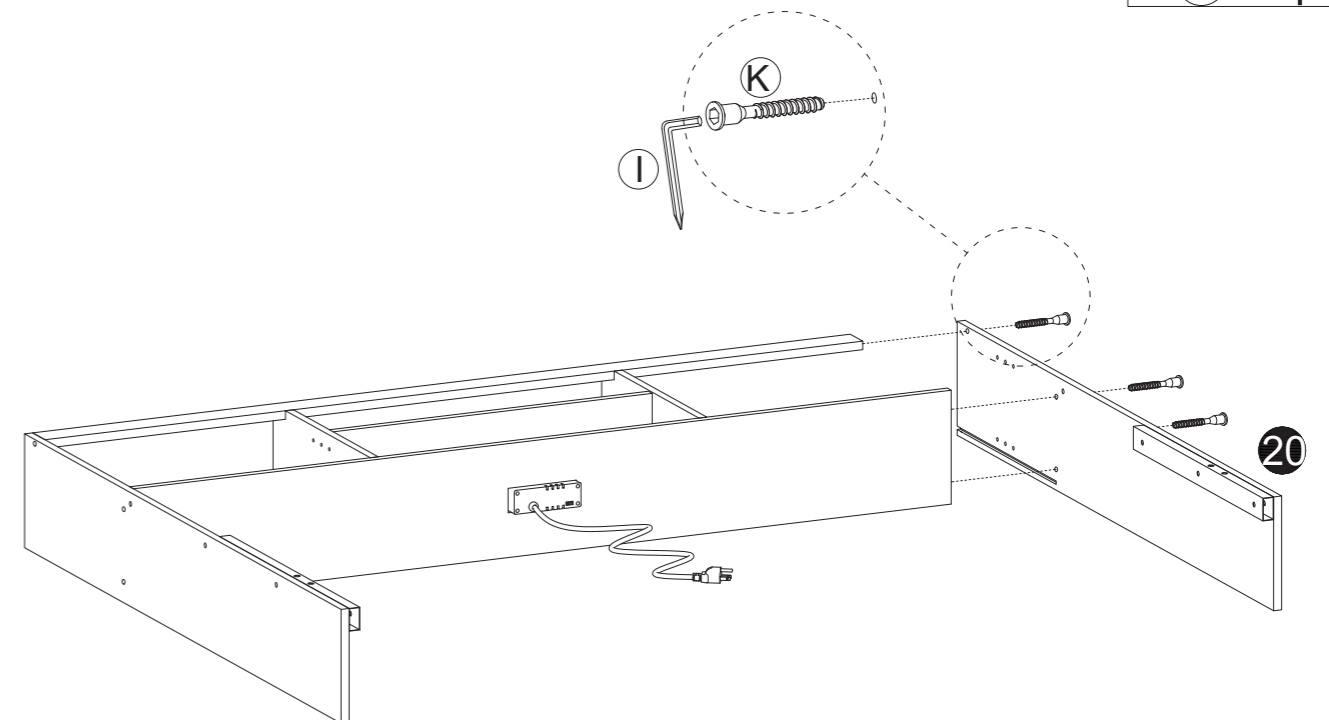
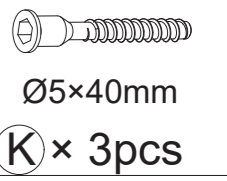

Step 7

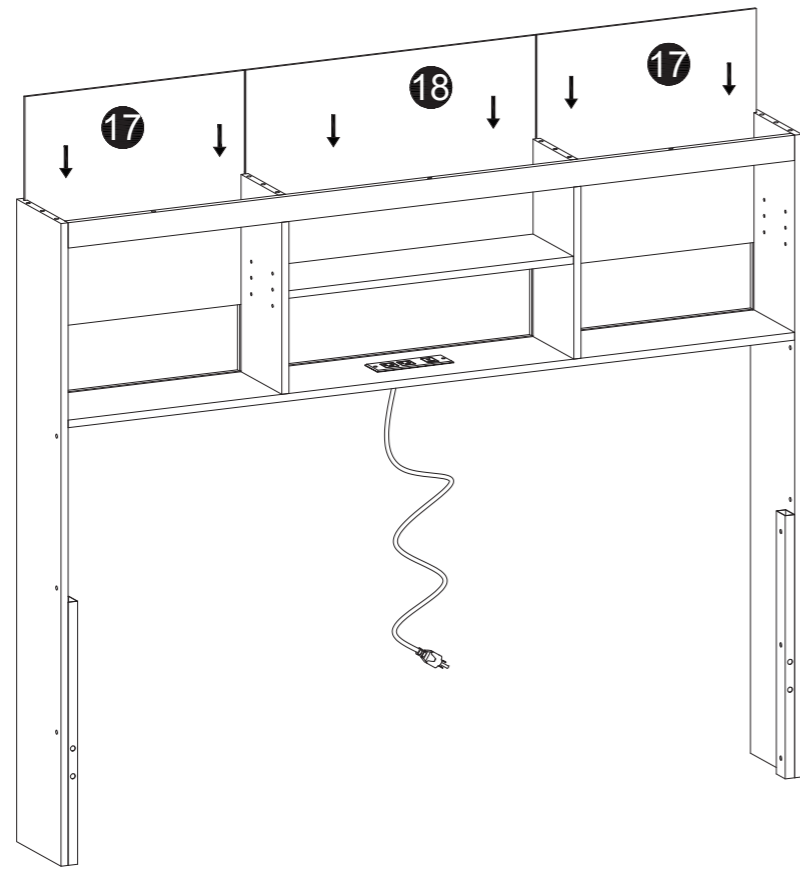

Step 8

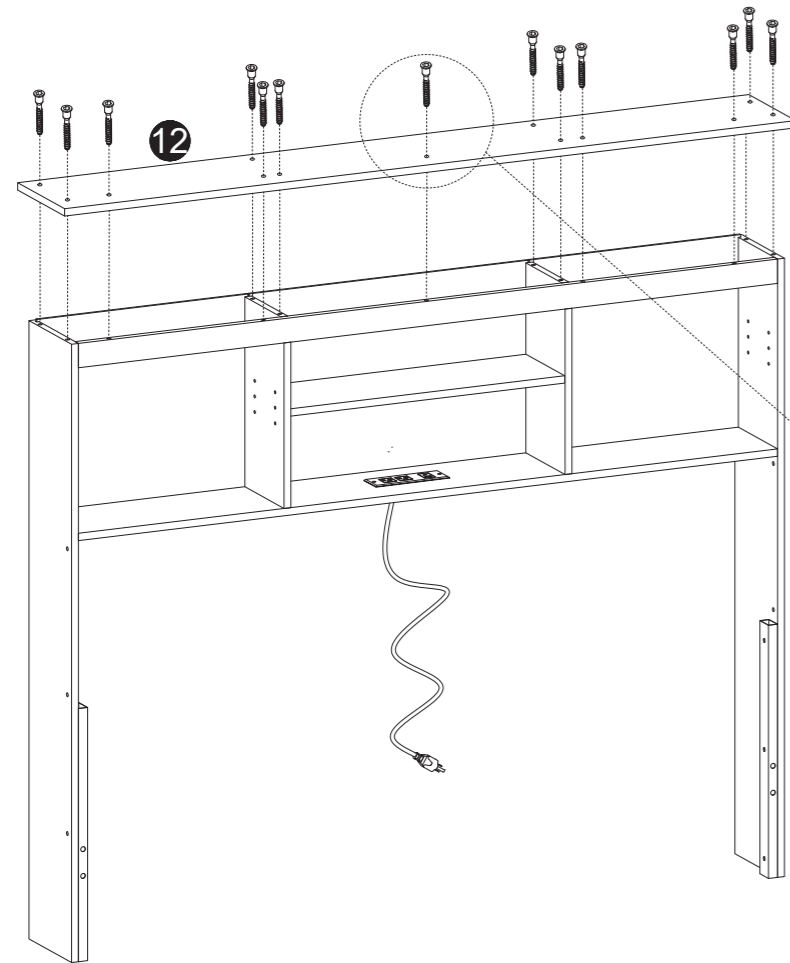

Ø5×40mm

(K) × 13pcs

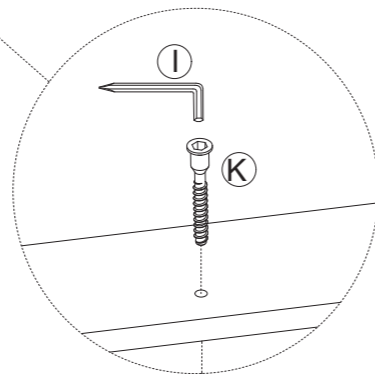

Step 9

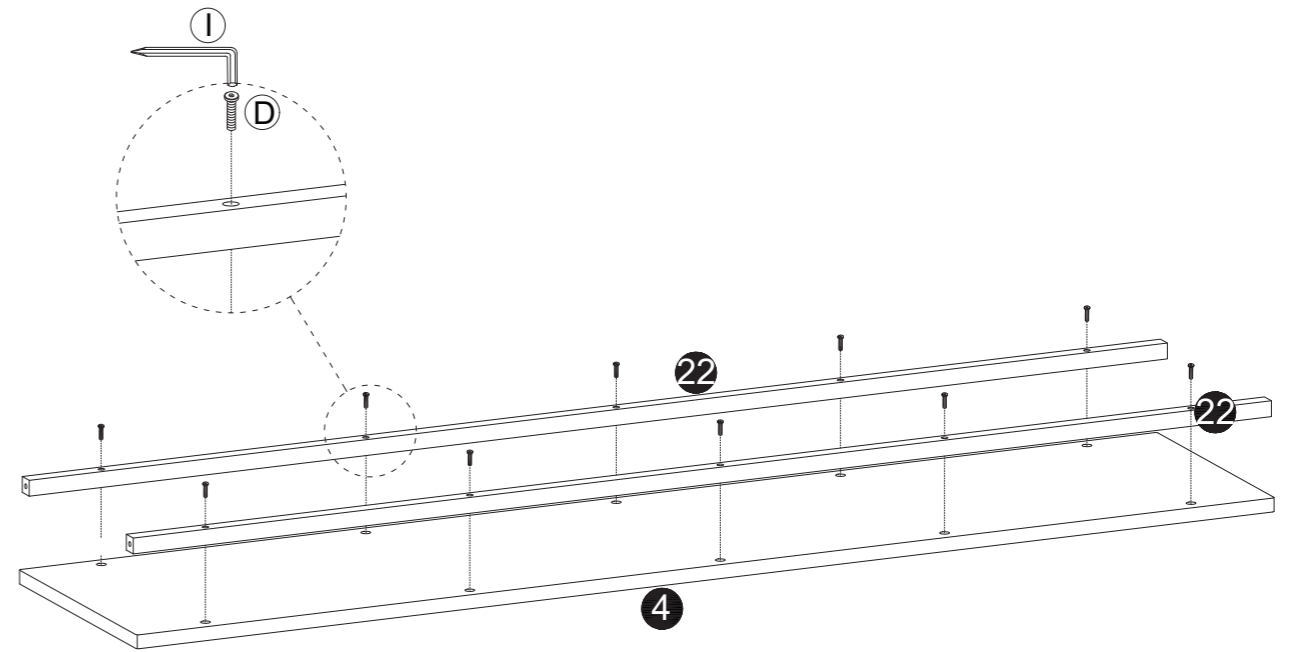

M6×30mm

(D) × 10pcs

Step 10

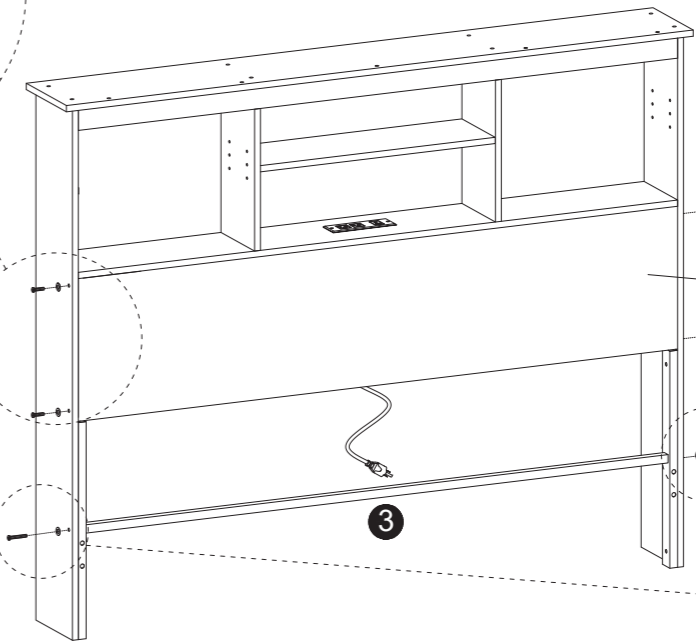
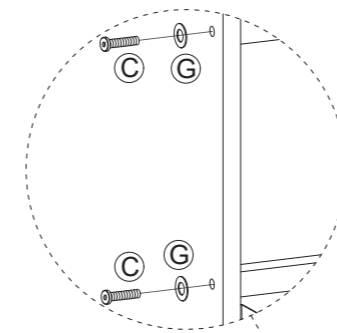

M6×55mm

(B) × 2pcs



M6×40mm

(C) × 4pcs



(G) × 6pcs

