

installation instructions:

SIGNATURE URETHANE BRACKET/OUTLOOKER

SAFETY INSTRUCTIONS

Make sure to use the correct tools recommended.

Wear safety goggles.

Follow fixture, power tools, and paint manufacturers' instructions and users manuals.

Use common sense and follow good construction practices.

Braces are not load-bearing, decorative use only.

TOOL & MATERIAL CHECKLIST

- | | |
|---|---------------------------------------|
| <input type="checkbox"/> Electric Drill | <input type="checkbox"/> Wood blocks |
| <input type="checkbox"/> Drill bit for pilot hole | <input type="checkbox"/> Adhesive |
| <input type="checkbox"/> Countersink bit | <input type="checkbox"/> Caulking gun |
| <input type="checkbox"/> Screws | |
| <input type="checkbox"/> Caulk | |

IMPORTANT INFO

- Clean installation surface and brace of all dirt and dust with a clean cloth or dry sponge.
- It is highly recommended that you paint/finish our brackets before installation.
- Once installed, you can apply any necessary touch-up paint/finish.
- Measure and mark the location where the bracket is going to be installed.
- All Signature Urethane brackets and outlookers are decorative only and are built as solid hollow channels to slip over wood blocking strips for easy installation.
- Wood blocking strips should fit snugly into the back of brackets and outlookers.

INSTALL INSTRUCTIONS:

1. Attach wood blocks to surface with screws.
2. The top and back pieces of bracket or outlooker will easily "slip" over wood blocking strips.
3. Screw through side of bracket into wood blocks to properly secure.
4. Use caulk to seal edges of bracket or outlooker against surface after installation.
5. Fill in any holes with caulk and smooth the surface with finger.
6. Let caulk dry. Once dry, lightly sand with extra fine sandpaper.
7. Touchup bracket or outlooker with paint as needed.

EXAMPLE DIAGRAM:

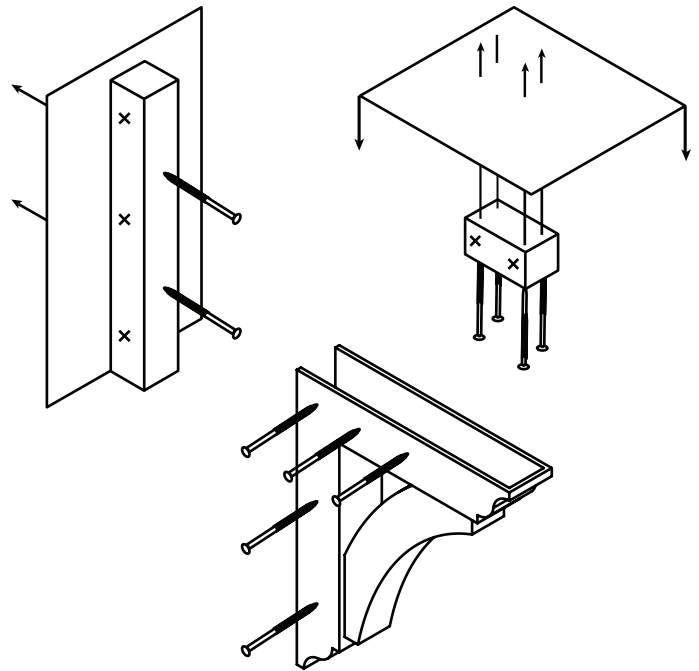

Industry leading manufacturer of urethane, PVC, wood, rustic, and metal millwork

We Can Help. Call (866) 607-0453

www.ekenamillwork.com