

INSTRUCTION MANUAL

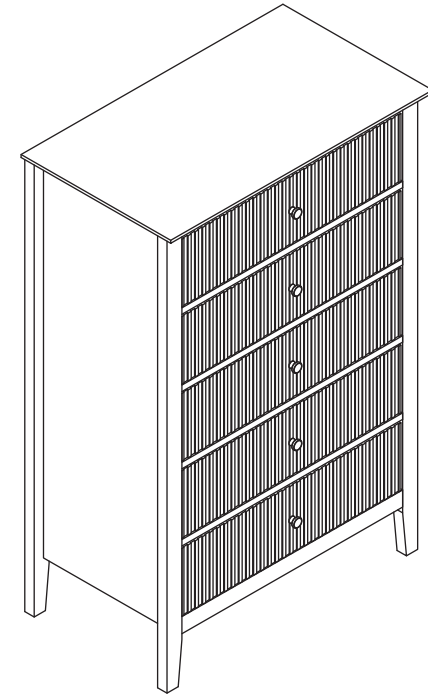

STORAGE CABINET

ASSEMBLY INSTRUCTIONS







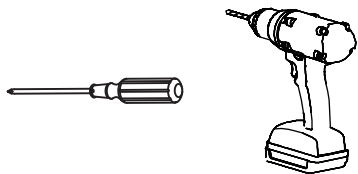



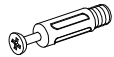









- Carefully unpack all the components and verify that all the necessary parts are included as listed in the packaging.
- Identify each component and refer to the provided assembly diagram or step-by-step instructions.
- Assemble the furniture in the order specified to ensure proper alignment and fit.
- Use the provided tools or recommended tools for assembly. Do not use excessive force when tightening screws or bolts.
- If any difficulties arise during assembly, consult the troubleshooting section or contact our customer support.



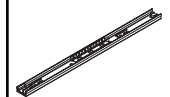

TOOLS REQUIRED

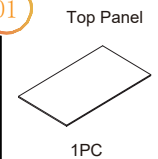
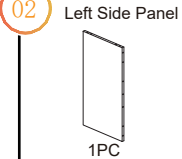
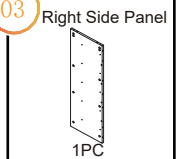

HARDWARE

<p>A M6x35mm Bolt</p>  <p>63PCS</p>	<p>B M15x10mm Eccentric Wheel</p>  <p>63PCS</p>	<p>C M8x30mm Wooden Dowel</p>  <p>26PCS</p>	<p>D M3x12mm Screw</p>  <p>40PCS</p>
<p>E M4x30mm Screw</p>  <p>25PCS</p>	<p>F M4x16mm Screw</p>  <p>5PCS</p>	<p>G Handle</p>  <p>5PCS</p>	<p>H Back Panel Latch</p>  <p>8PCS</p>
<p>I M3x16mm Screw</p>  <p>8PCS</p>	<p>J Washer</p>  <p>4PCS</p>	<p>K Plastic Expansion</p>  <p>2PCS</p>	<p>L Anti-tipping Strap</p>  <p>2PCS</p>
<p>M M4x14mm Screw</p>  <p>2PCS</p>	<p>N M4x35mm Screw</p>  <p>2PCS</p>	<p>O 300mm Cabinet Slider</p>  <p>10PCS</p>	<p>P 300mm Drawer Slider</p>  <p>10PCS</p>
<p>Q M4x25mm Screw</p>  <p>2PCS</p>	<p>R Screw Hole Cover</p>  <p>30PCS</p>		

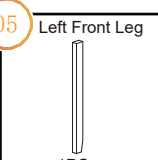
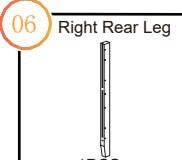
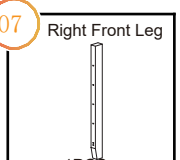
PART

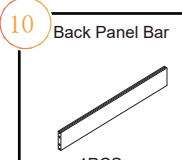
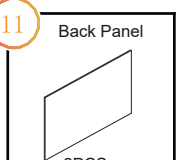
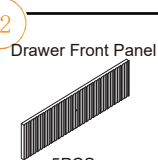
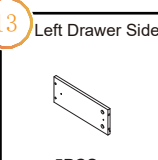
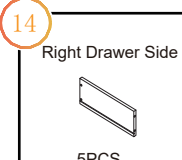
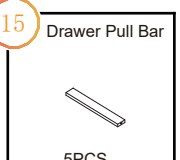
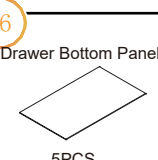
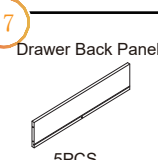
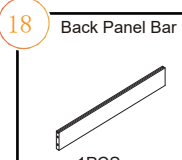
<p>01 Top Panel 1PC</p> 	<p>02 Left Side Panel 1PC</p> 	<p>03 Right Side Panel 1PC</p> 	<p>04 Left Rear Leg 1PC</p> 
<p>05 Left Front Leg 1PC</p> 	<p>06 Right Rear Leg 1PCS</p> 	<p>07 Right Front Leg 1PCS</p> 	<p>08 Lower Drawer Bar 5PCS</p> 
<p>09 Top Horizontal Bar 1PCS</p> 	<p>10 Back Panel Bar 1PCS</p> 	<p>11 Back Panel 2PCS</p> 	<p>12 Drawer Front Panel 5PCS</p> 
<p>13 Left Drawer Side 5PCS</p> 	<p>14 Right Drawer Side 5PCS</p> 	<p>15 Drawer Pull Bar 5PCS</p> 	<p>16 Drawer Bottom Panel 5PCS</p> 
<p>17 Drawer Back Panel 5PCS</p> 	<p>18 Back Panel Bar 1PCS</p> 		

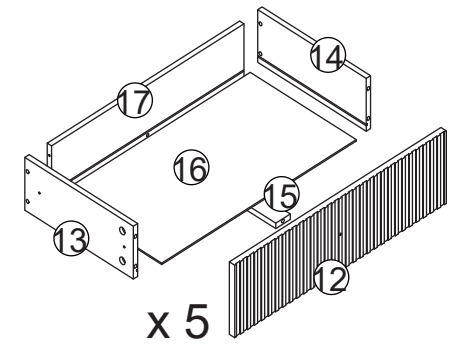
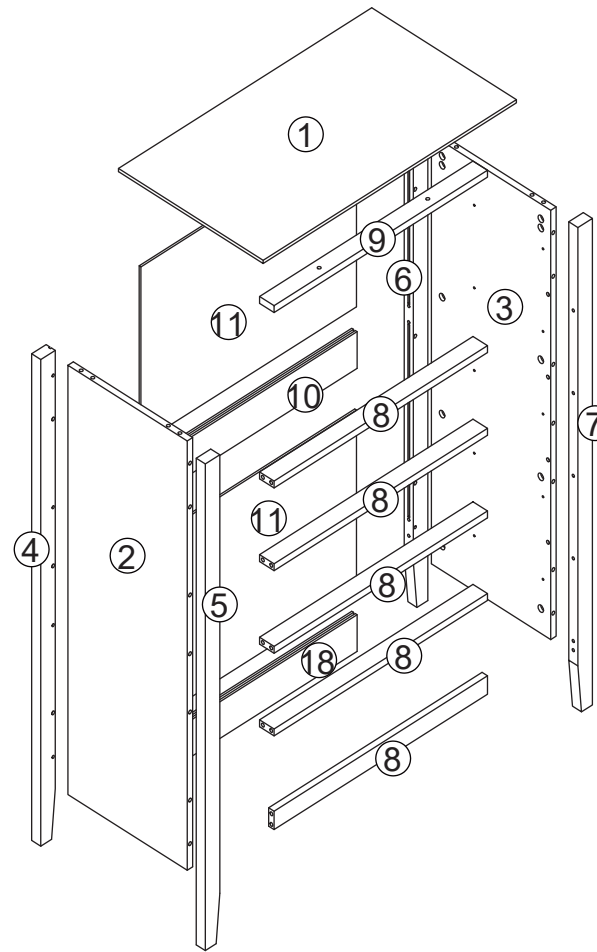

STEP 1

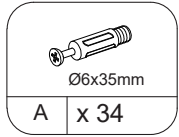
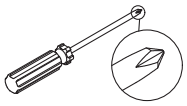

Secure screw A to panels 4, 5, 6, and 7

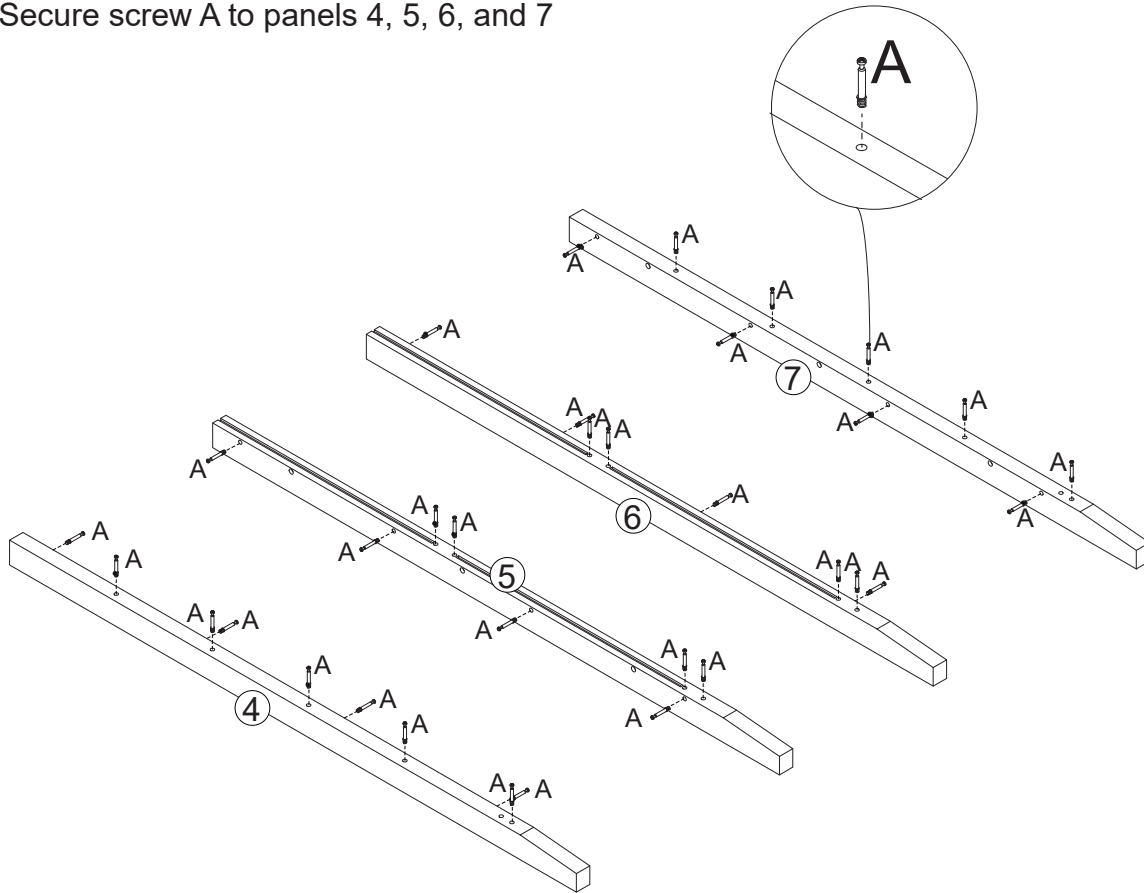

STEP 2

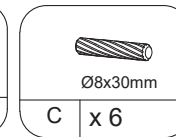
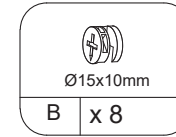
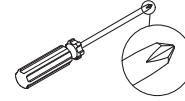

Connect panels 4 and 5 to panel 2 using wooden dowel C, then tighten eccentric wheel B clockwise

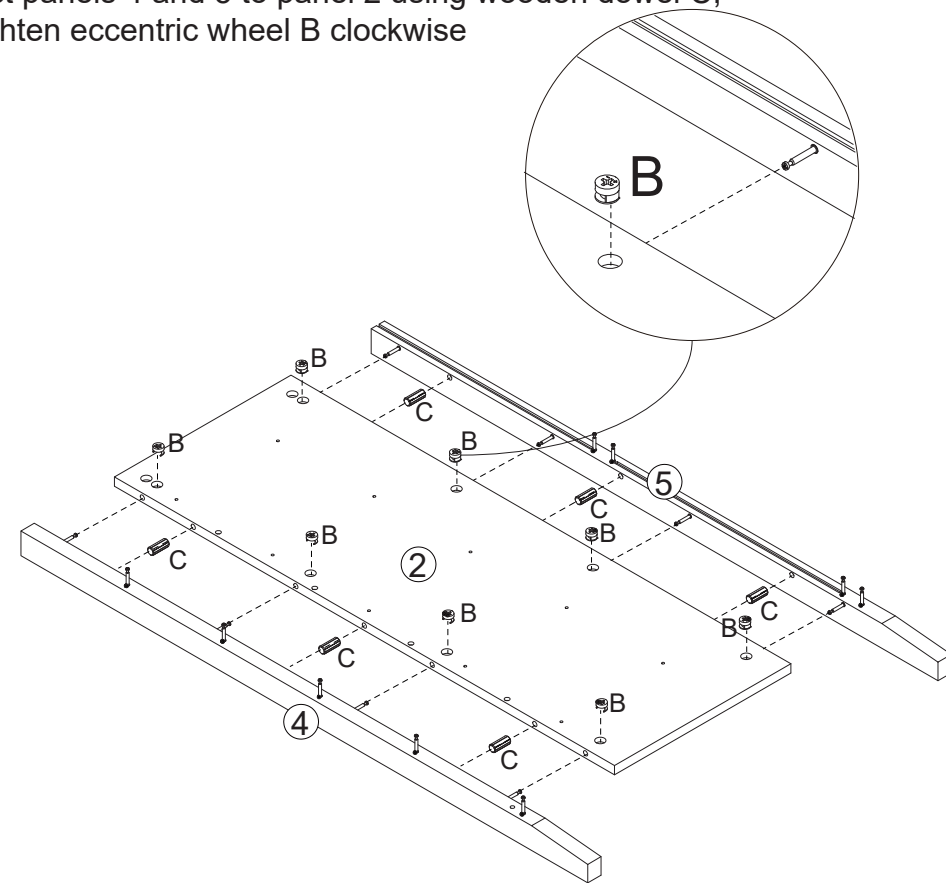

STEP 3

Take out the P and O slides, and slowly pull out the O slide until it is fully extended. Locate the plastic soft indicator, then press down while gently pulling out the O slide, allowing for the smooth separation of the P and O slides.

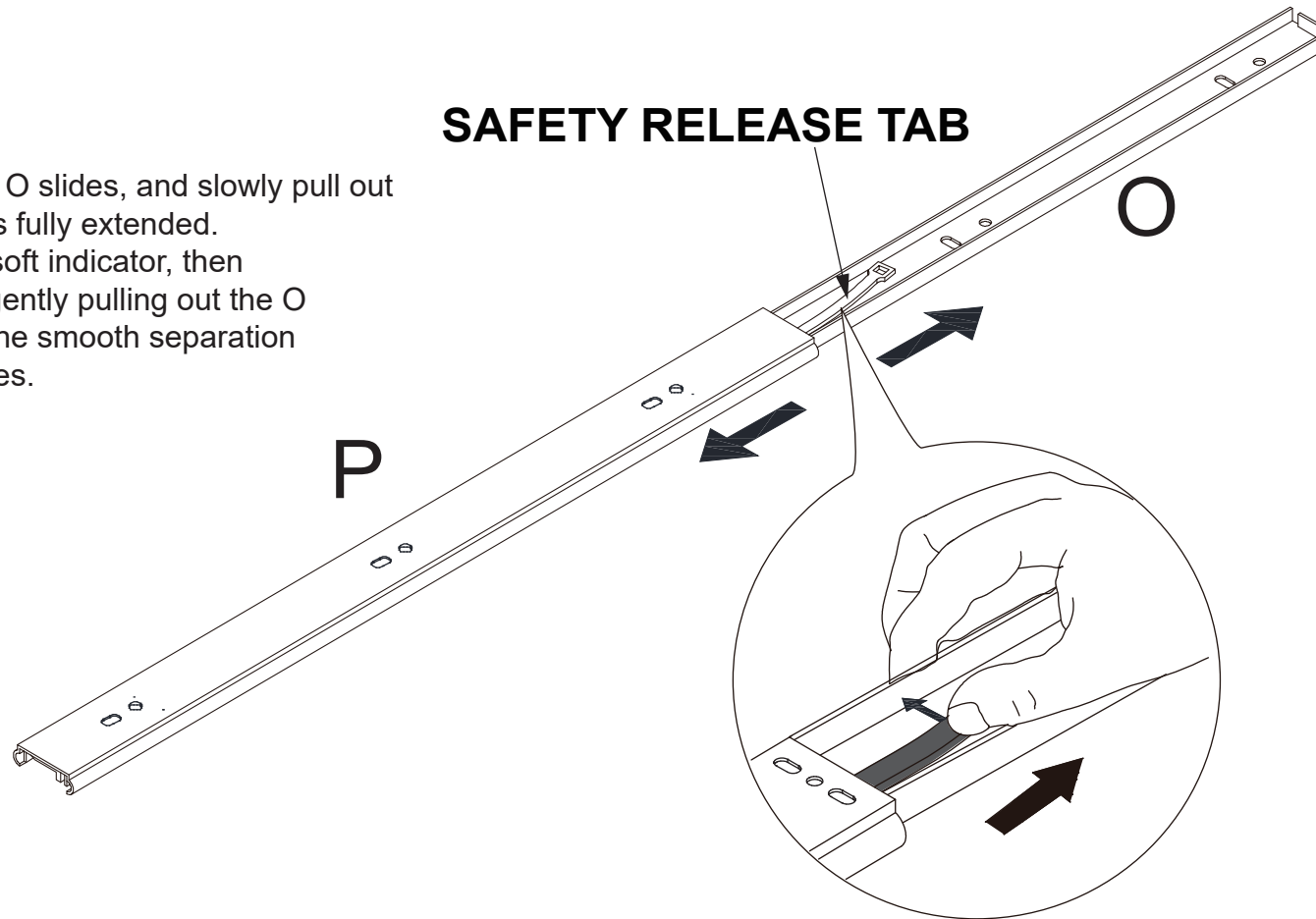

STEP 4

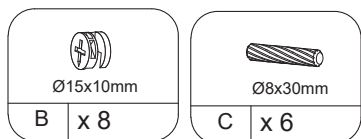
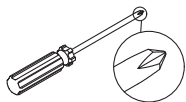

Connect panels 6 and 7 to panel 3 using wooden dowel C, then tighten eccentric wheel B clockwise

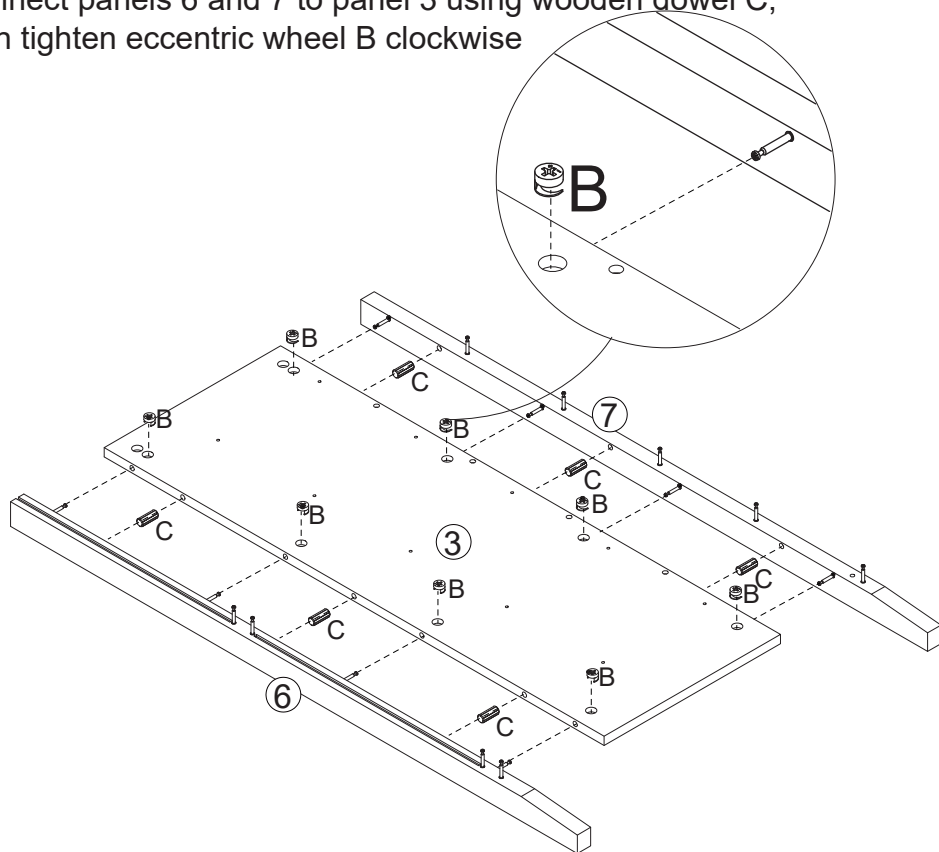

STEP 5

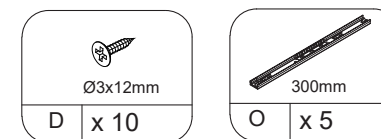
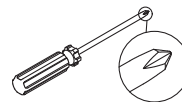

Secure the slide rail O onto panel 2 using screw D

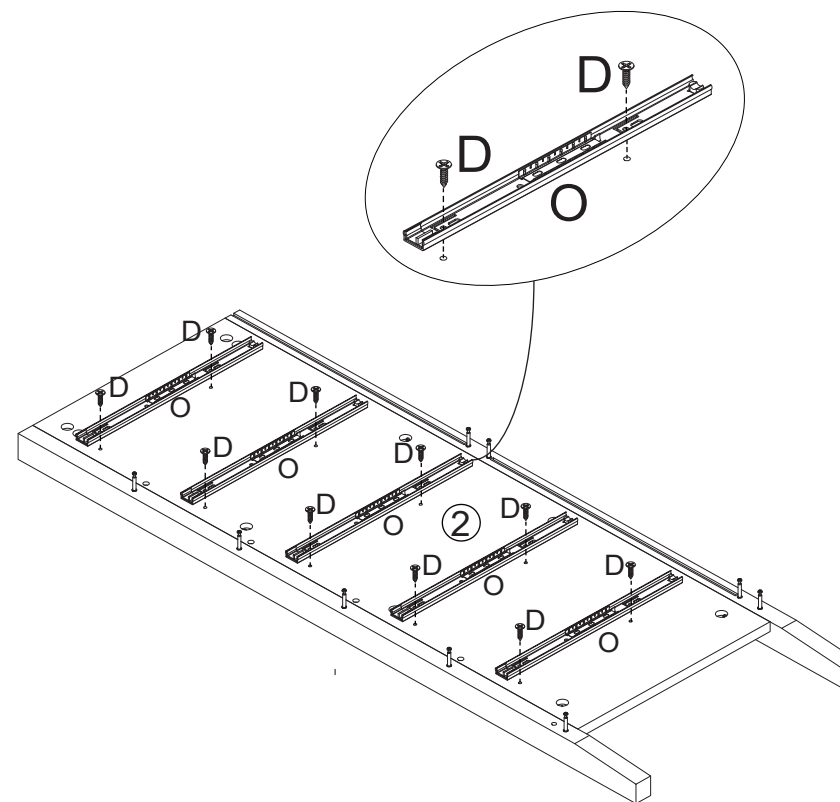

STEP 6

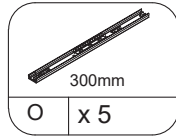
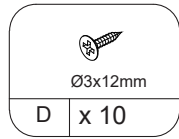
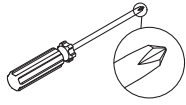

Secure the slide rail O onto panel 3 using screw D

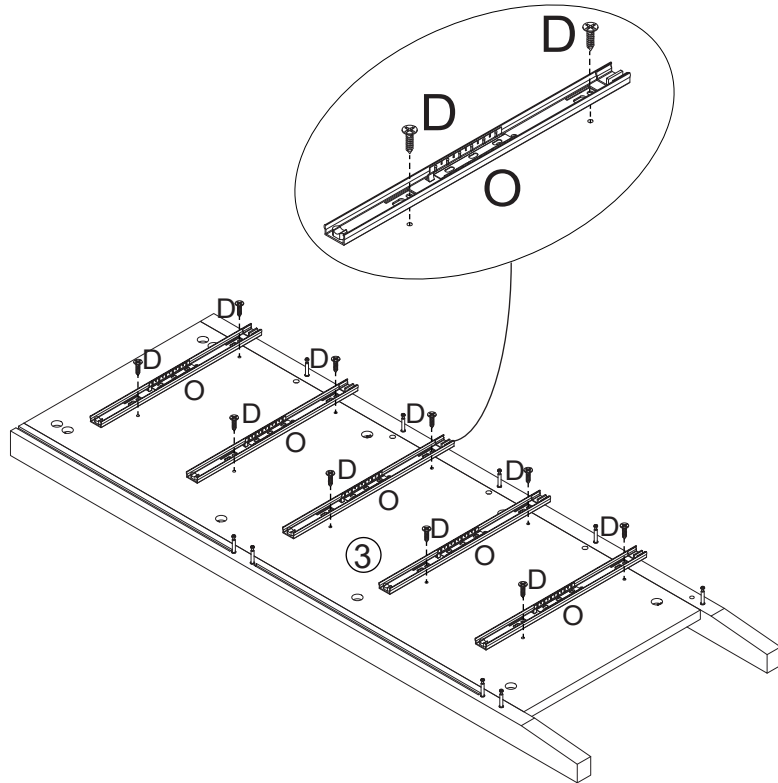

STEP 7

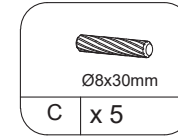
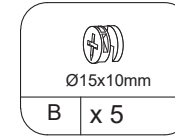
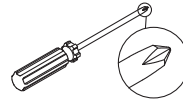

Connect panel 8 to panel 2 using wooden dowel C, then tighten eccentric wheel B clockwise

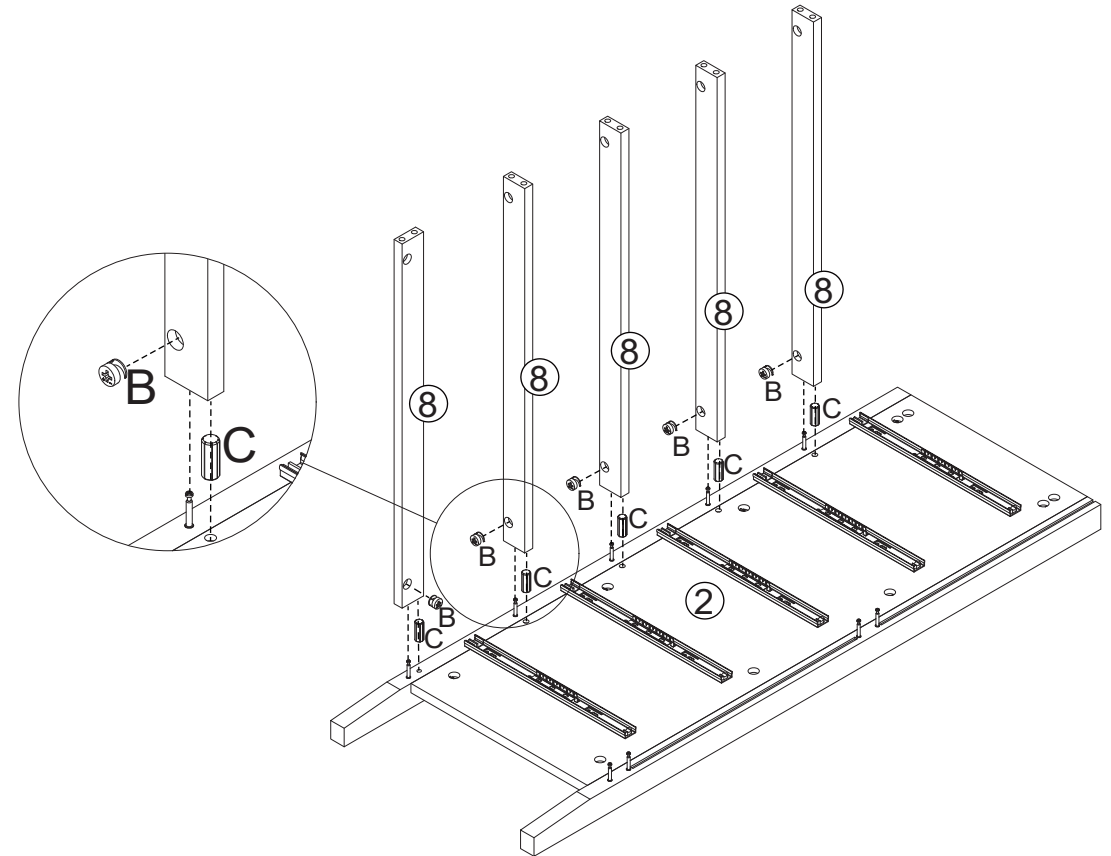

STEP 8

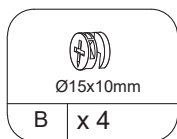
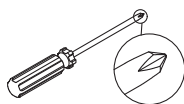

Connect panels 10 and 18 to panel 2 using screw B, then tighten eccentric wheel B clockwise

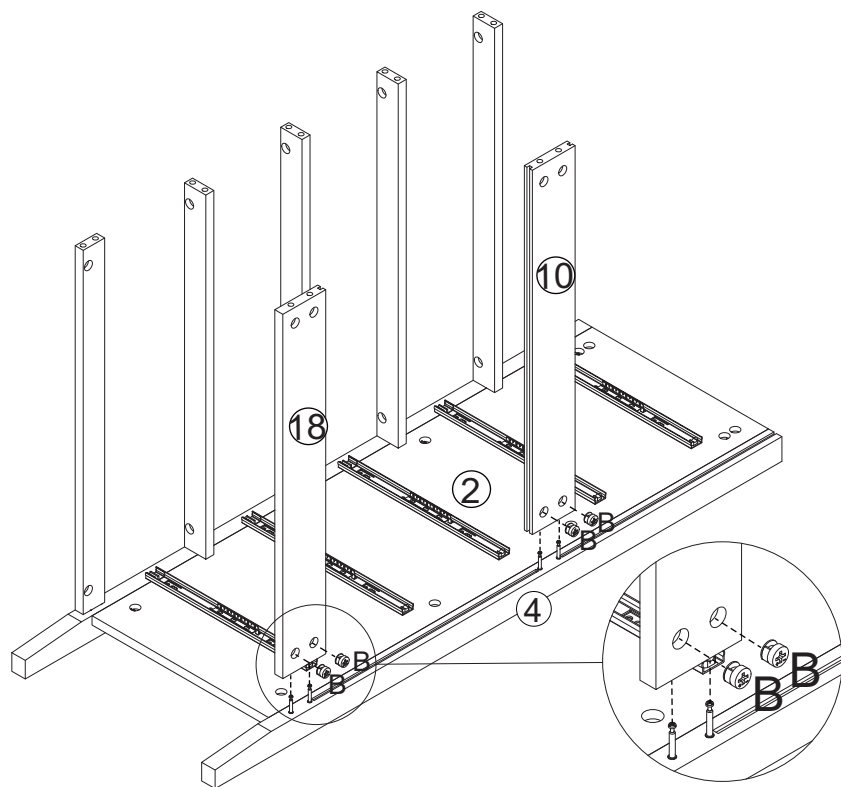

STEP 9

Slide and insert back panel 11 into the assembled component

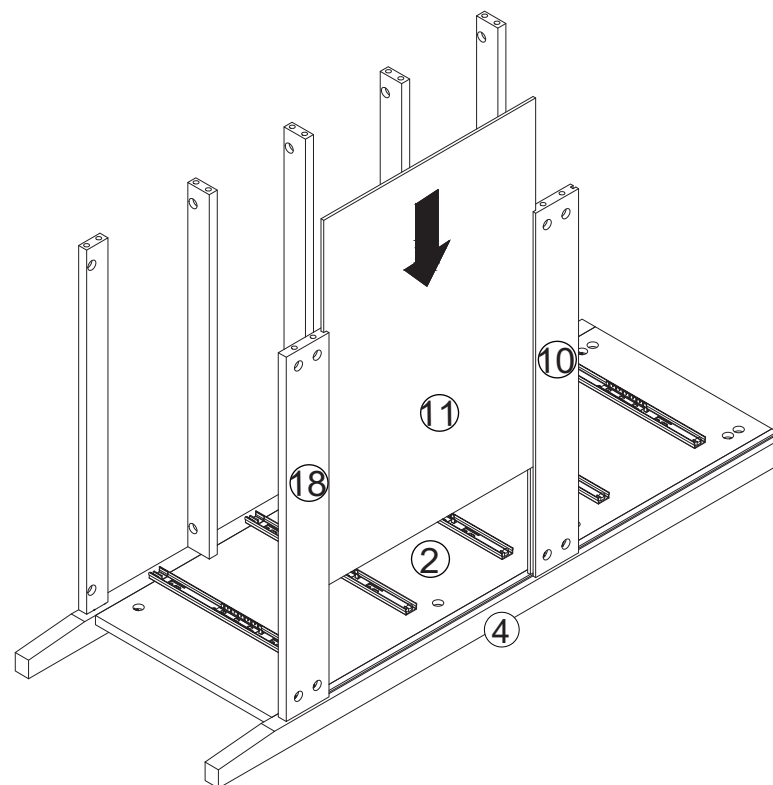

STEP 10

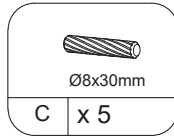
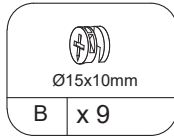
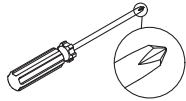

Connect panel 3 to panel 2 using wooden dowel C, then tighten eccentric wheel B clockwise

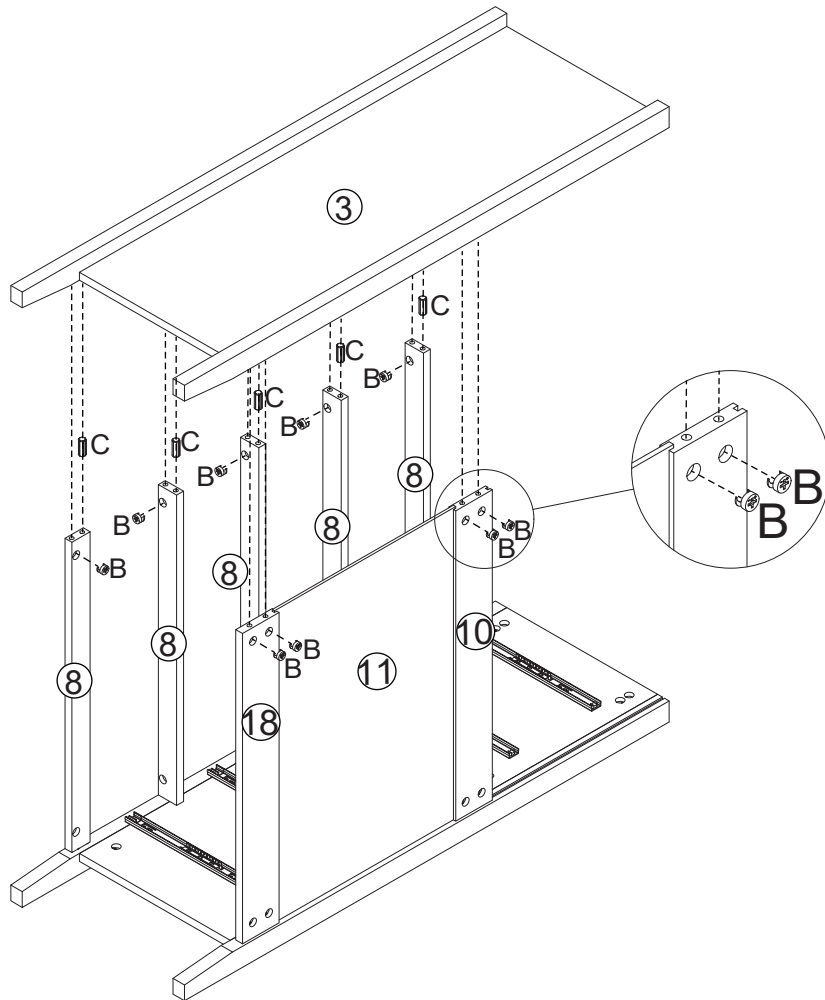

STEP 11

Slide and insert back panel 11 into the assembled component

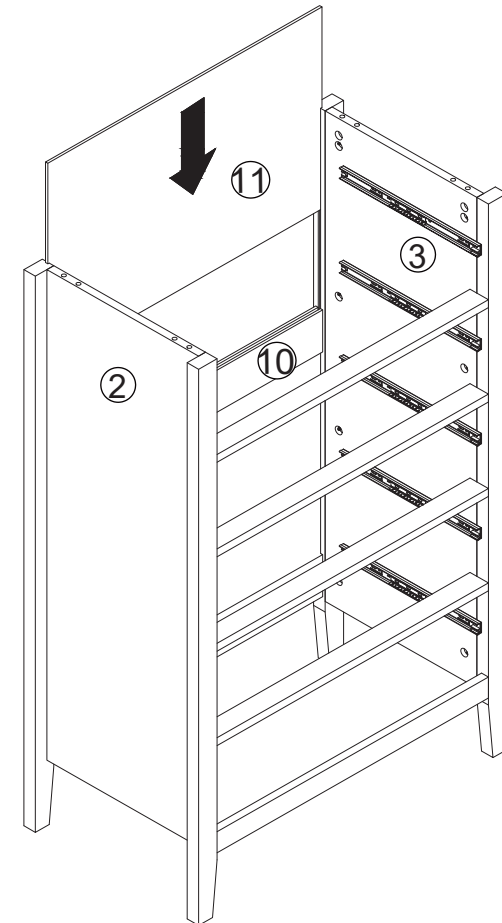

STEP 12

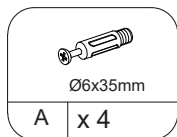
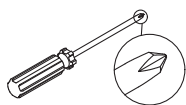

Secure bolt A onto panel 1

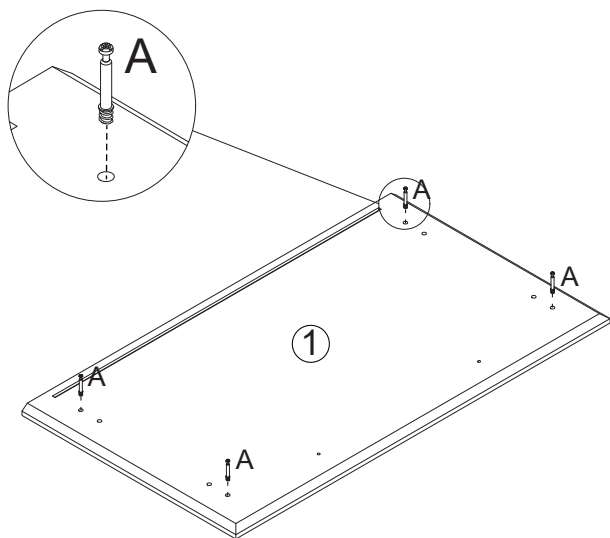

STEP 13

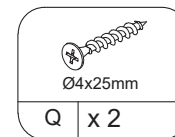
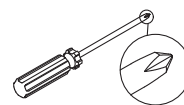

Secure panel 9 onto panel 1 using screw Q

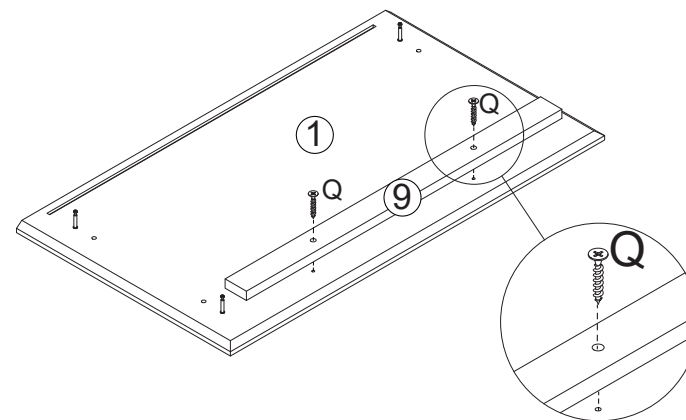

STEP 14

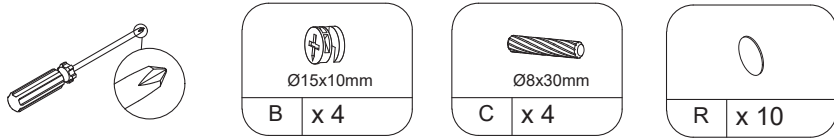

Connect panel 1 to panels 2 and 3 using wooden dowel C, then tighten eccentric wheel B clockwise, and finally, apply hole sticker R

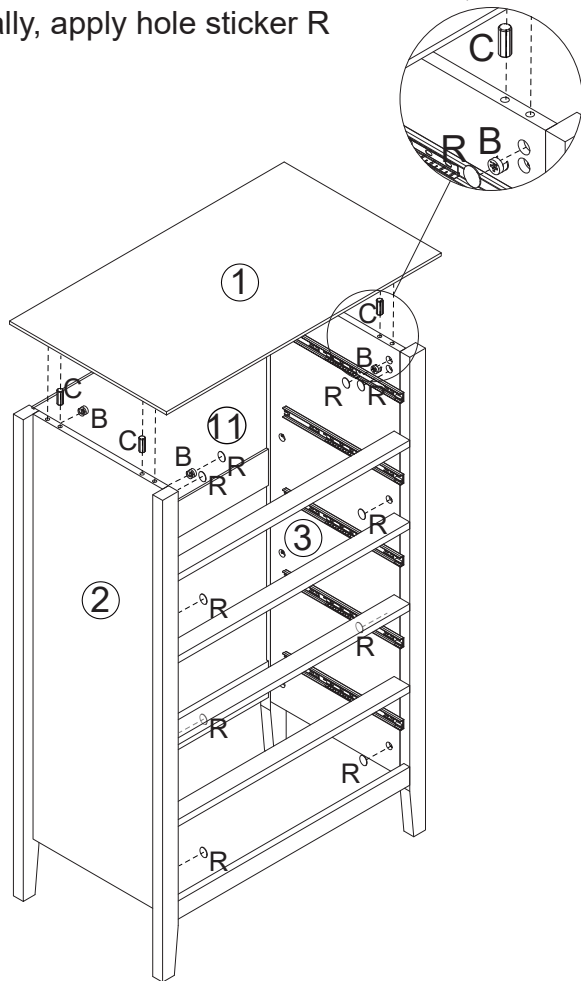

STEP 15

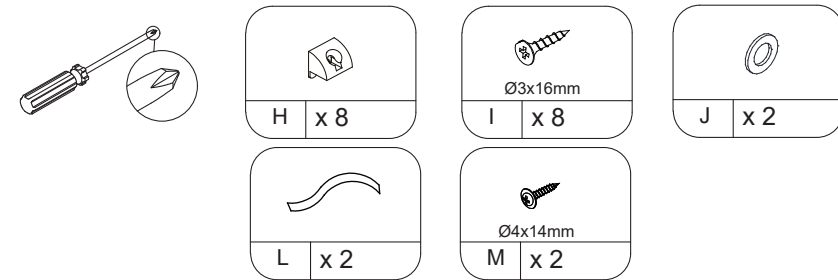

Secure back panel fastener H to the back panel using screw I, then install the anti-tip device on panels 4 and 6
Please install all the back panel fasteners for enhanced stability

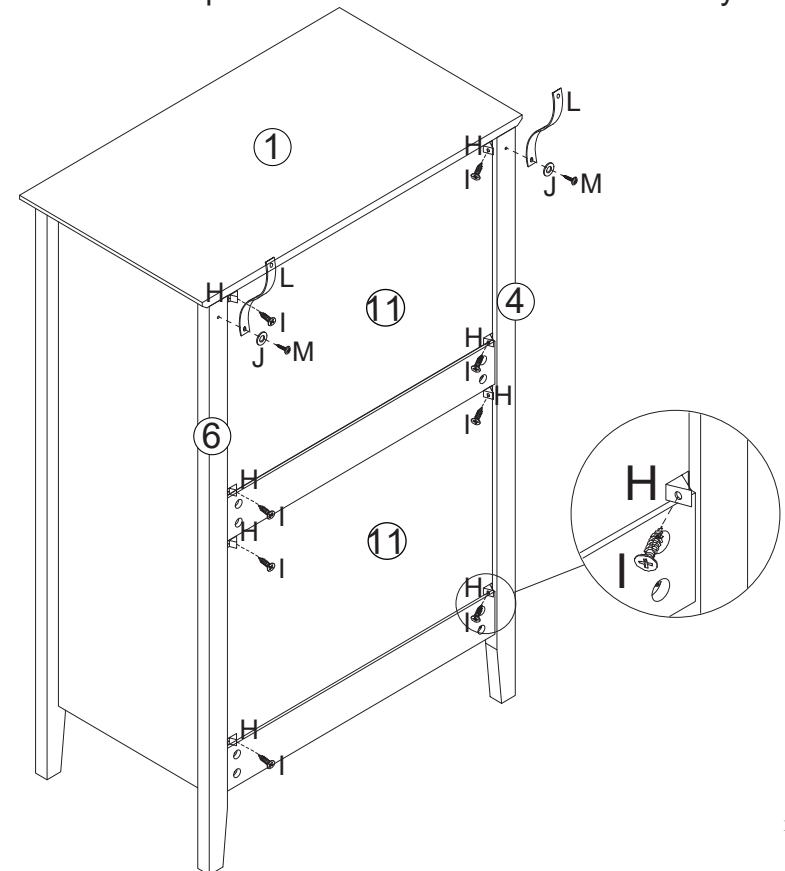

STEP 16

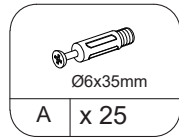
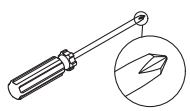

Secure bolt A onto panel 12

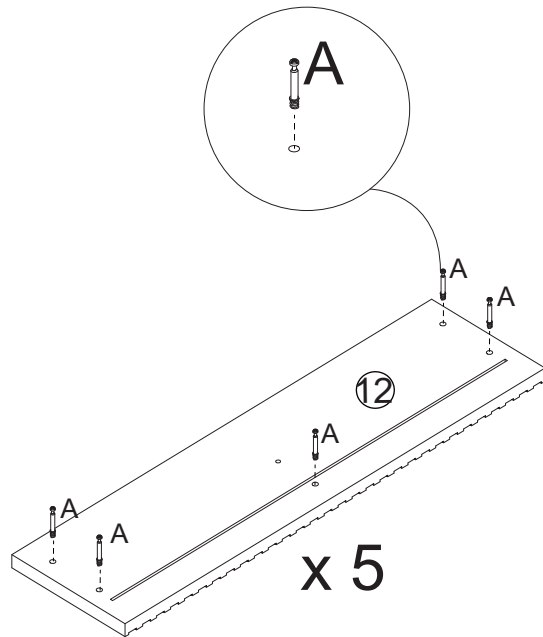

STEP 17

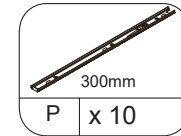
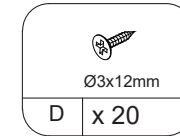
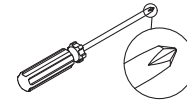

Secure the slide rail P onto panels 13 and 14 using screw D

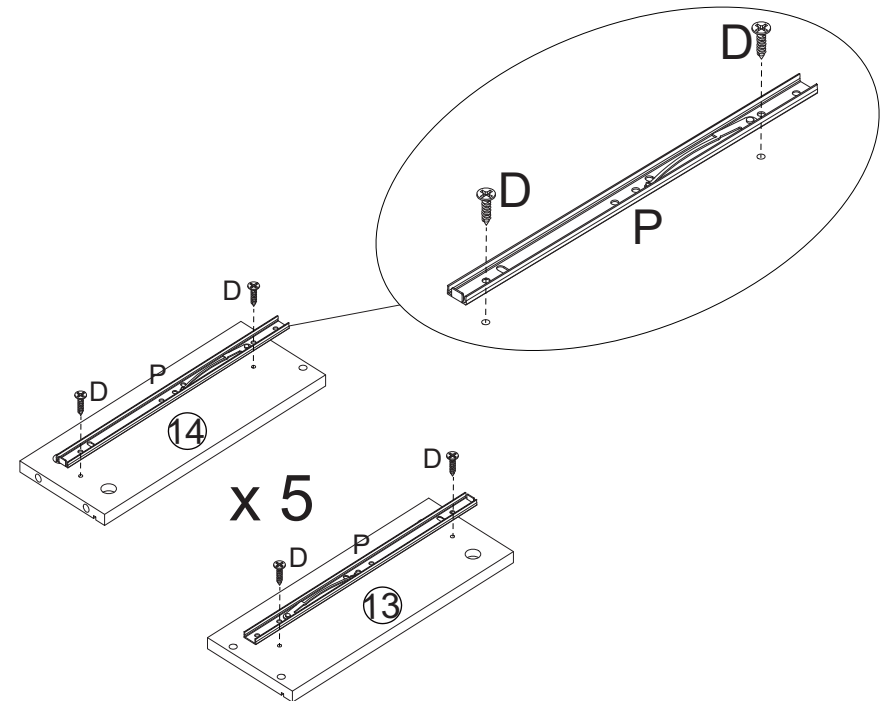

STEP 18

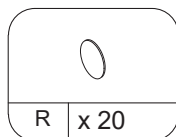
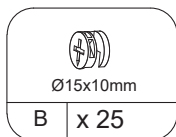
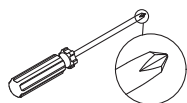

Connect panel 13, 14, 15 to panel 12 using screw B, then tighten eccentric wheel B clockwise, and finally, apply hole sticker R

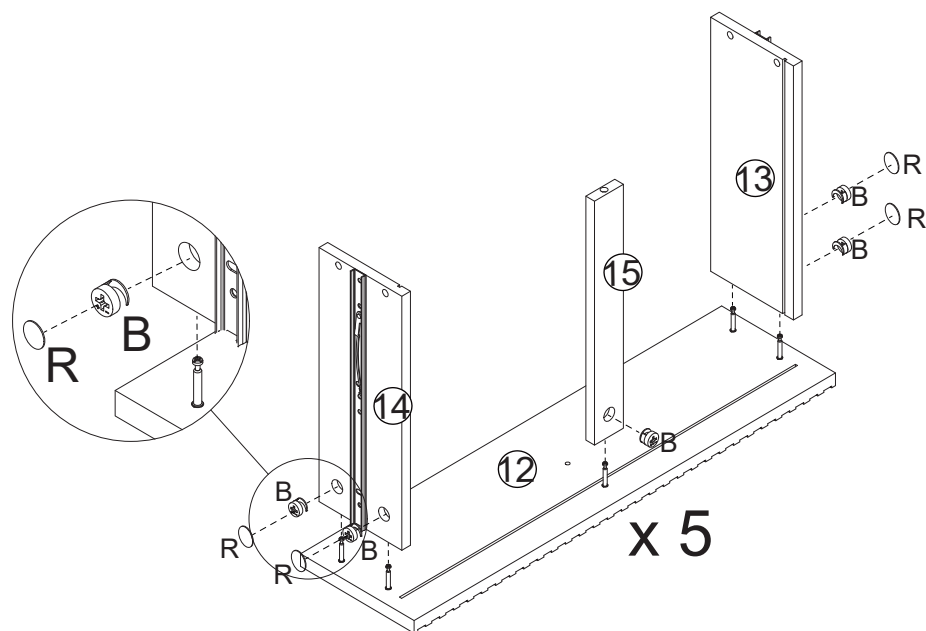

STEP 19

Slide and insert drawer bottom panel 16 into the assembled component

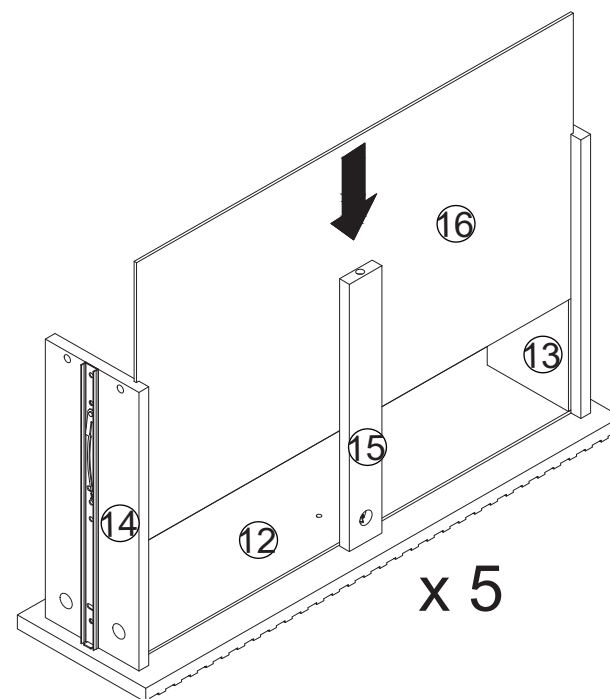

STEP 20

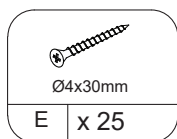
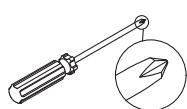

Attach panel 17 to the assembled components and secure it with screw E

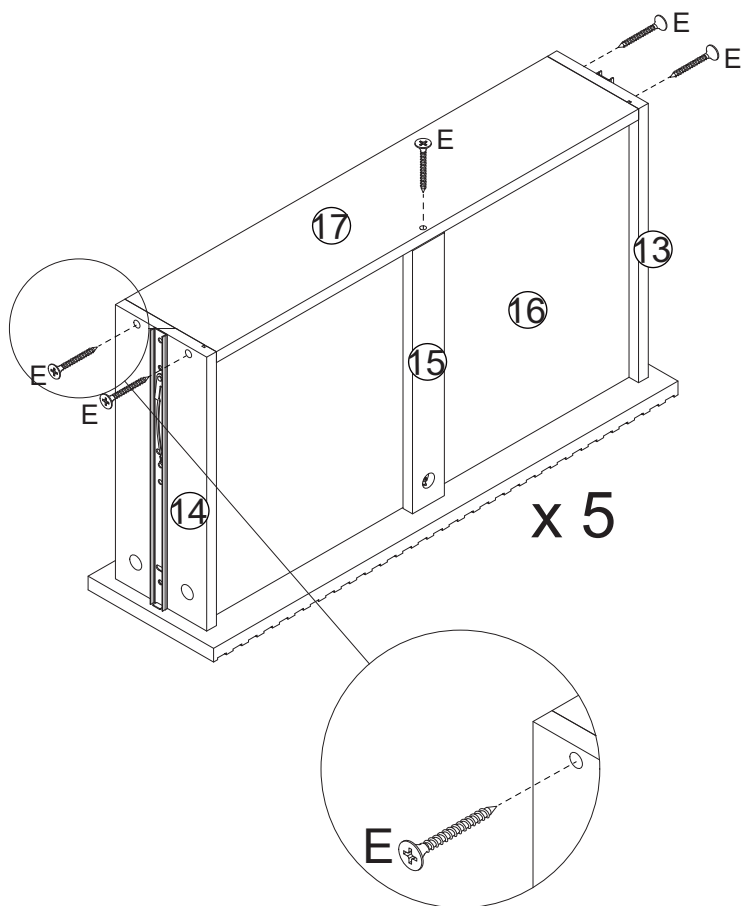

STEP 21

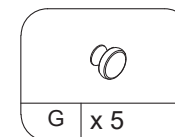
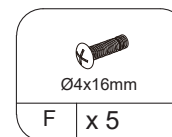
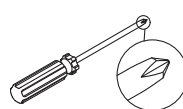

Secure handle G onto panel 12 using screw F

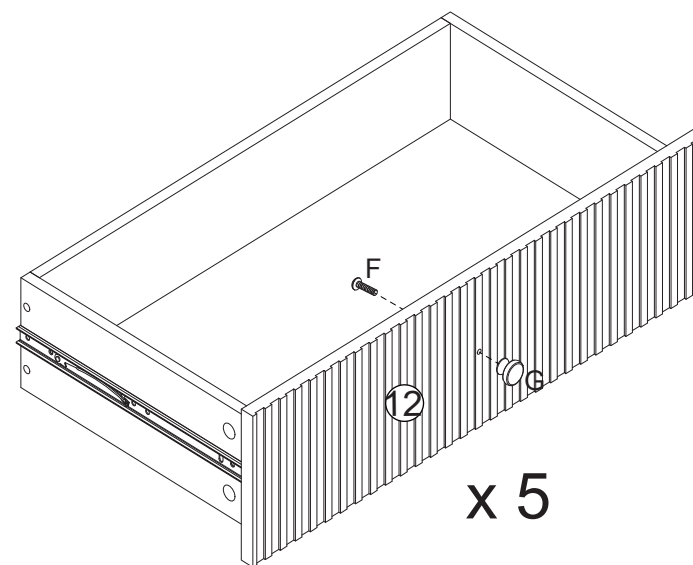

STEP 22

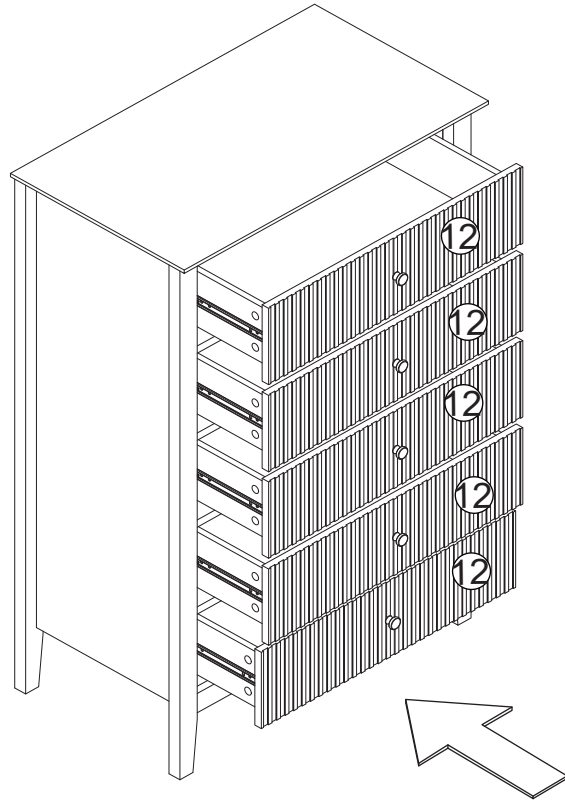

Place the drawer inside the cabinet.

STEP 23

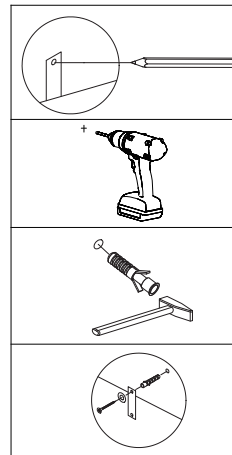
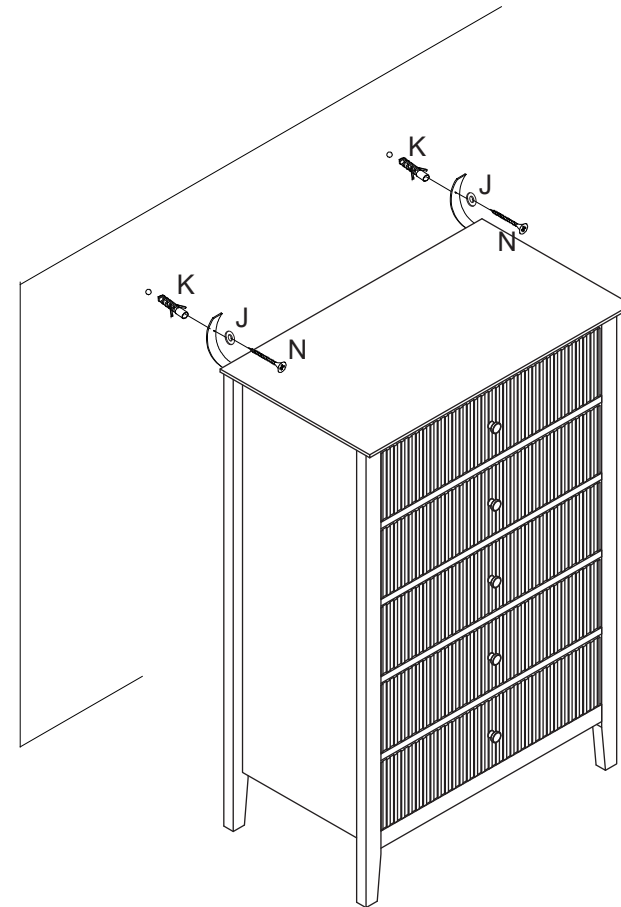
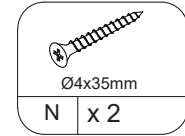
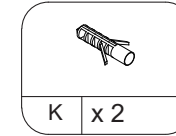
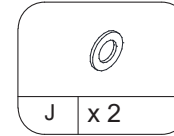
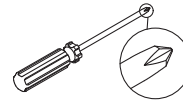

Use components K, J, and N to assemble hardware L on the wall to prevent tipping.

MAINTENANCE AND CARE



Following these few basic steps will help to ensure that you enjoy your furniture for a long time:

Do not expose your furniture to direct sunlight, dampness or any heat, like a hot cup of coffee or tea.
Always use a coaster.

Dust with a clean, damp, lint free cloth.

Use a damp cloth with water or mild detergent to clean all surfaces - do not use chemicals or paint thinner which will fade the surface.

Place a piece of felt or a pad under the legs of your furniture to avoid scratching the floor.

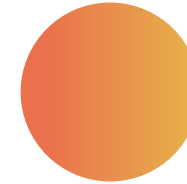

WARRANTY INFORMATION



Warranty Coverage: Our warranty provides protection against manufacturing defects in materials and workmanship for a specified period from the date of purchase, as outlined in the accompanying warranty documentation.

Exclusions: The warranty does not cover damages resulting from misuse, negligence, accidents, normal wear and tear, unauthorized repairs or modifications, improper assembly, or failure to adhere to the care and maintenance guidelines provided.