

# Installation Diagram

Note: Parts list with those in the hardware list (installed) means it is already installed in the finished product, not in the hardware package!!!!

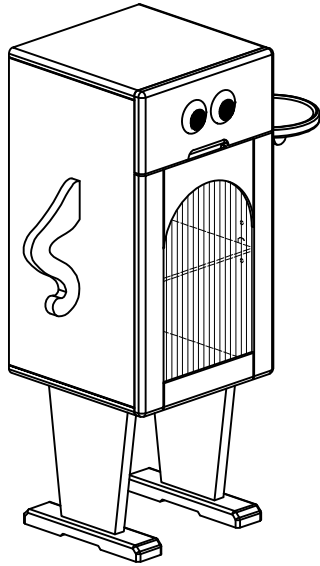

# Partial Forms

Num.	Name	icon	norm	quantity
1	Cabi net		550*300*300mm	1
2	Leg		260*250*55mm	2
3	Glass Lami nates		267*250*5mm	1
4	Left hand		220*109*17mm	1
5	Right-hand side		165*96*17mm	1
6	Pallets		∅160*17mm	1
7	Drawers		300*137*267mm	1
8	Door		410*300*17mm	1

# Hardware Forms

Num.	Name	norm	speci fi cation	quanti ty
A	Hexagon socket screw		M6*30MM	8
B	Flat gasket		M6*13MM	8
C	Allen key		M4*57MM	1
D	nonwoven mat		∅25*3	4
E	L-shaped laminate tray		∅6*20*16MM	4
F	no-nail sticker		60*60MM	2
G	perfect paste		∅20MM	8
H	Straight Arm Cushion Hinge		∅26cup	2

This product by the wood inspection, paint inspection in full compliance with national quality inspection standards, qualified to give the factory, to confirm that the packaging is intact for sale. To ensure our commitment, customers are welcome to our after-sales service to provide valuable advice!

Product Name	furniture
qualified	Qualified
Grade	first-class



Step 1

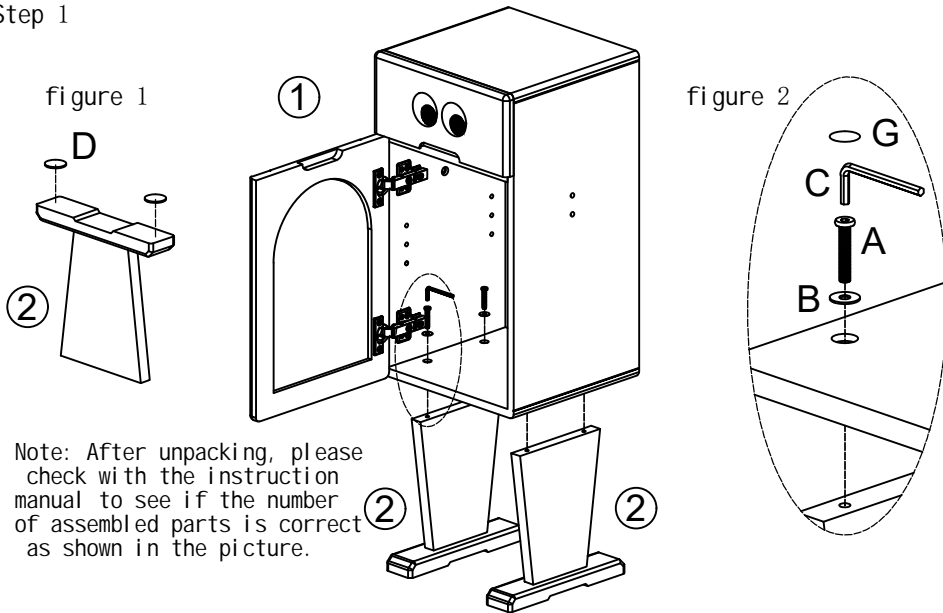

As shown in figure 1, attach hardware D to the bottom of part 2.  
As shown in figure 2, connect part 1 part 2 with hardware A/B/C and cover it with G.

Step 2

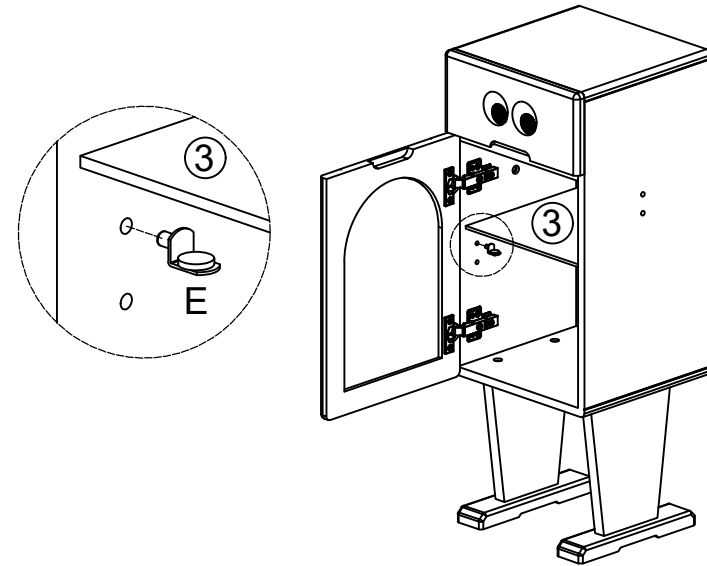

As shown in the figure, insert the hardware E into the holes of the same height and put in the part 3.

Step 3

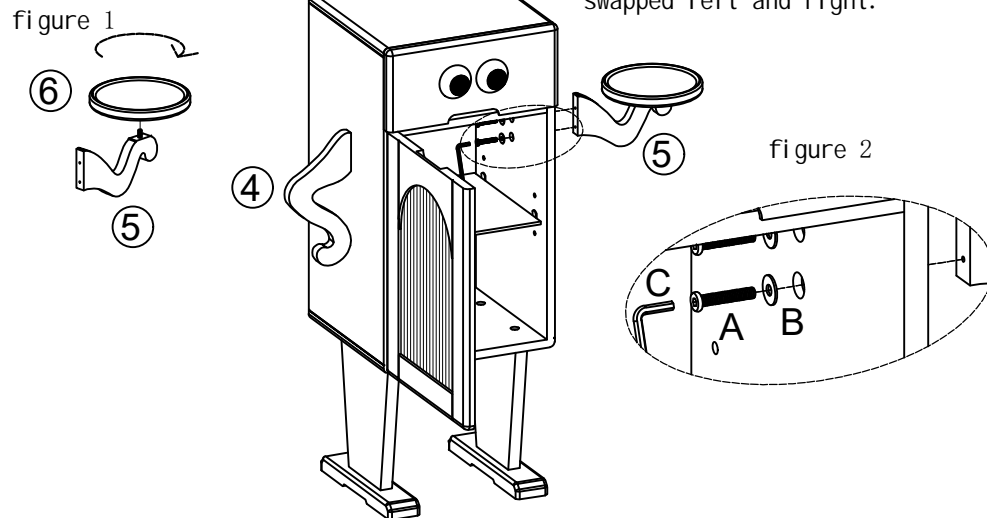

▶As in Figure. 1, assemble the parts 5 parts 6 .  
▶As in Figure 2, connect the parts grouped in step 2 with part 4 and the grouped parts 5/6 with hardware A/B/C, and then cover them with G.

Step 4

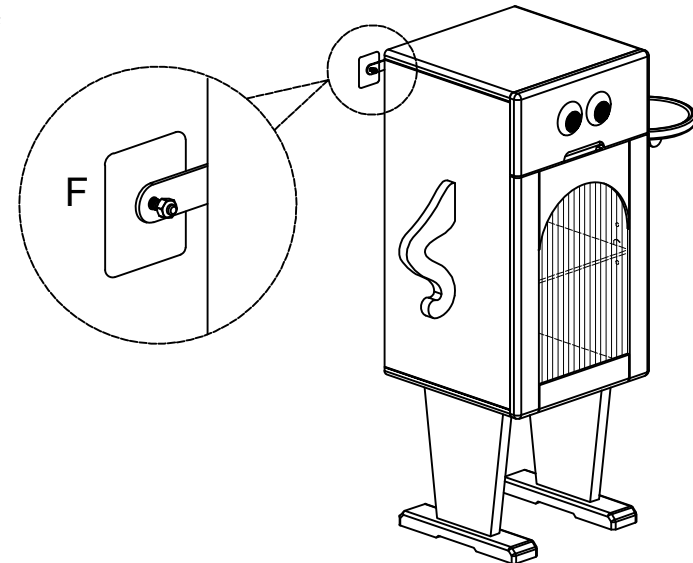

▶As shown in the picture, fix the parts grouped in step 3 to the wall with hardware F.  
▶Assembly is complete.