

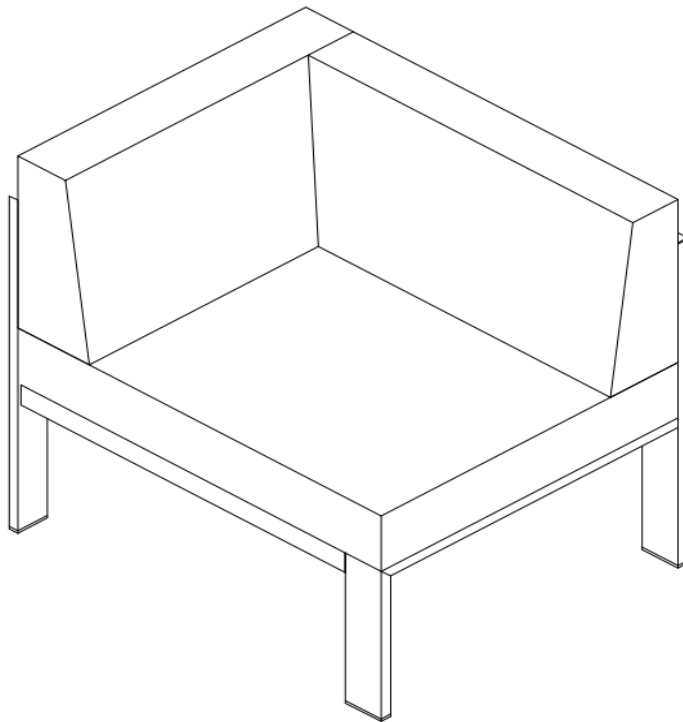

# Assembly Instructions

**Caution : You must read this before you proceed**

## Sofa Corner

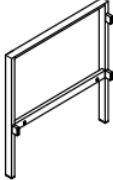

### Parts List

Label	Picture	Description	QTY
A		Side Panel	1
B		Back Support Bar	1

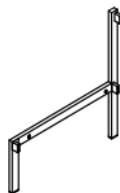
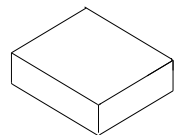
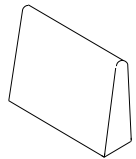
C		Seat Panel (Labeled with 'face' and 'bottom')	1
D		Leg Support Bar	1
E		Seat Cushion	1
F		Back Cushion	2

## Hardware

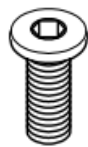
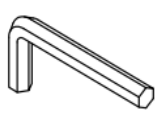
Label	Picture	Description	QTY
①		Bolt (M6*20MM)	11
②		Allen Key	1

## Assembly Preparation

Before Beginning Assembly:

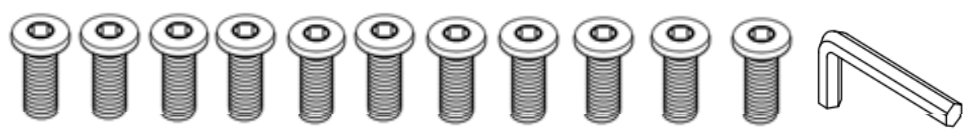

Page 2

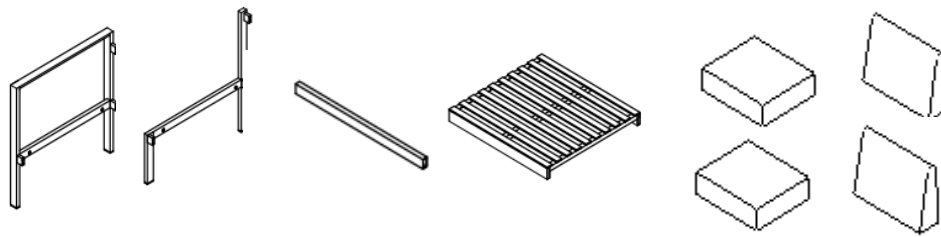

- Read instructions, cover to cover-



- Have 2 adults on hand for assembly-



- Do not assemble on flooring or carpet-



- Assemble on a clean non-marring surface (packing foam)-



- Save all packaging until finished-

## Assembly Steps

### Overview

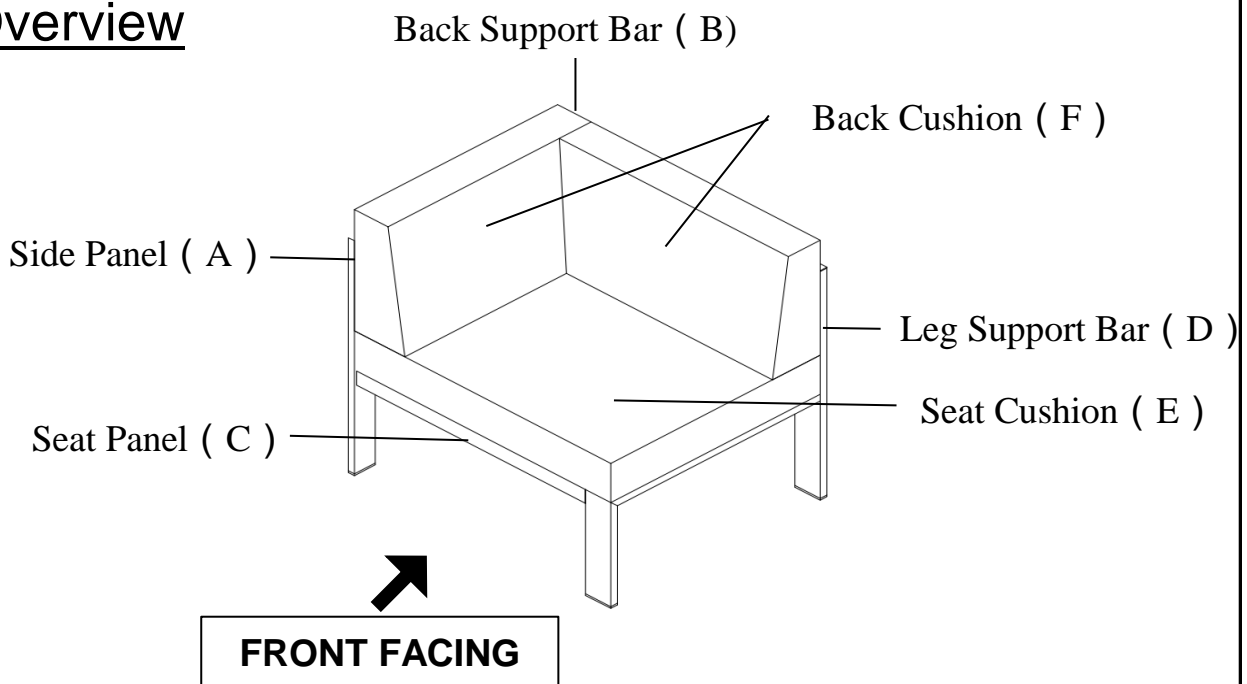

This Sofa Corner has multiple parts and may require up to 30 minutes to assemble. To give you an overview of the Sofa parts, the above picture is to help you put the various parts into perspective. Please read through the instructions below to familiarise yourself with the parts and steps before assembly.

## Step 1

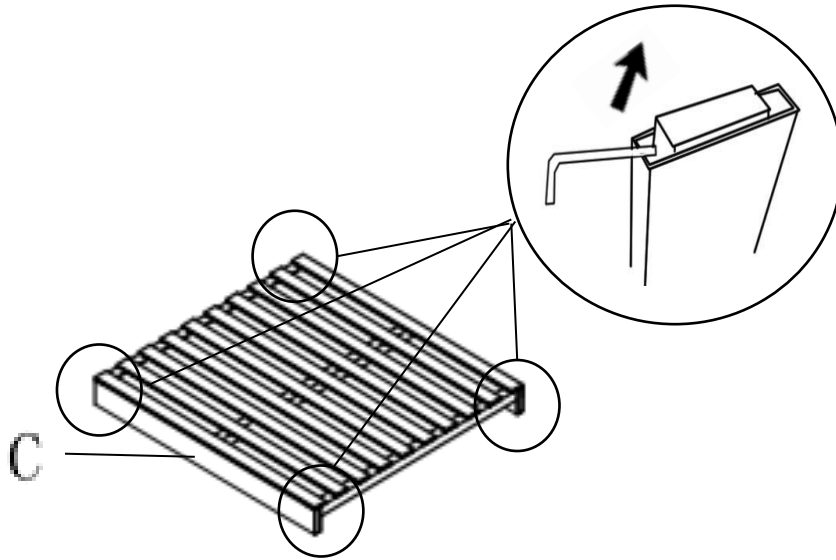

Open the carton and place all the parts onto a clean, non-marring surface.

Remove the plastic plugs in the four ends of the Seat Board(C) using Allen Key(②) as shown above.

## Step 2

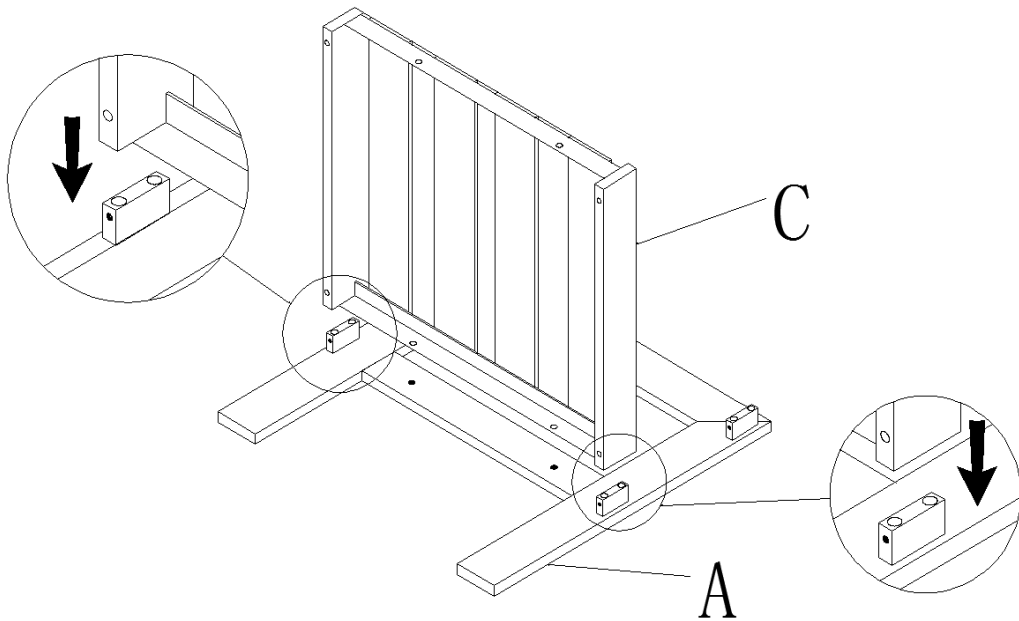

Place the Side Panel(A) with its inside facing up.  
Insert the Seat Panel(C) into the Side Panel(A).

### Step 3

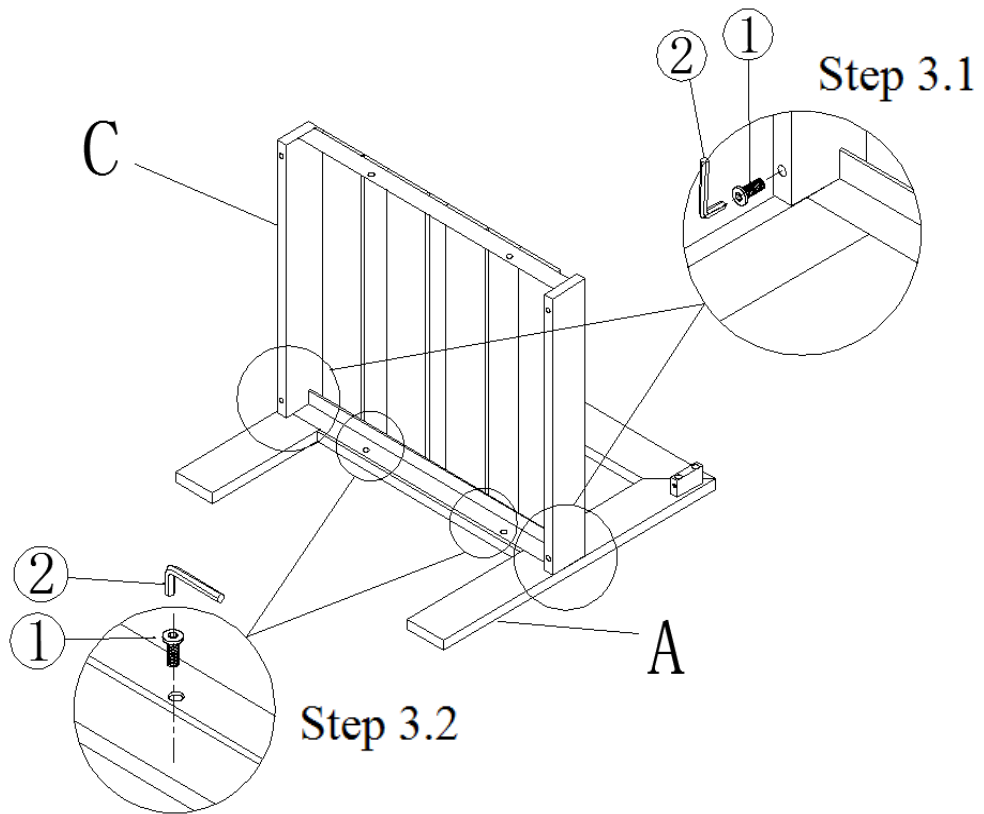

**3.1)** Attach the Seat Panel(C) to Side Panel(A) using Bolts(①) with Allen Key(②) as shown above.

**3.2)** Attach the Seat Panel(C) to Side Panel(A) using Bolts(①) with Allen Key(②) as shown above.

### Step 4

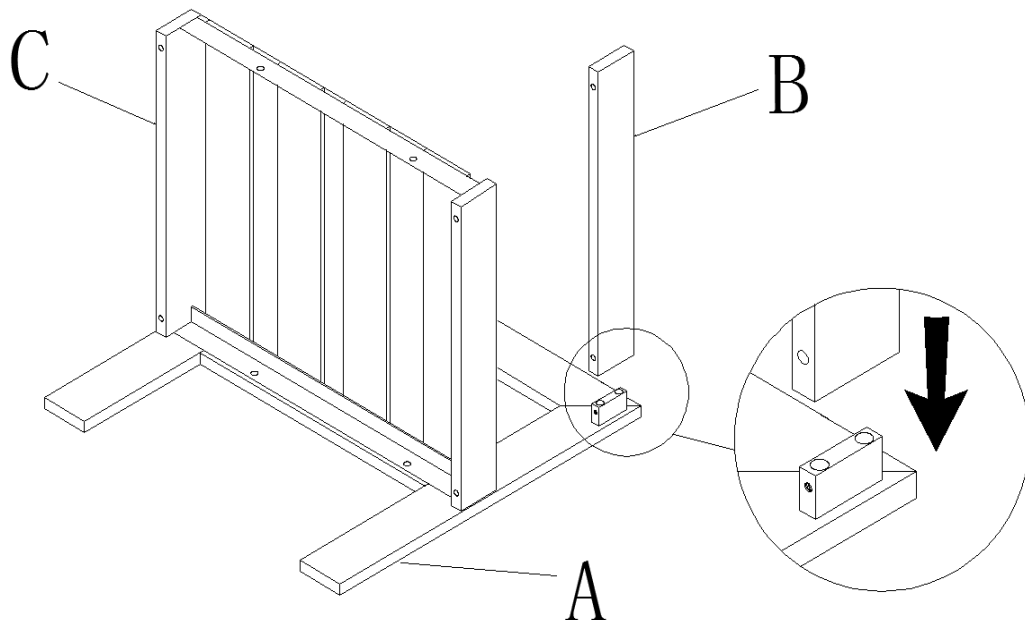

Insert the Back Support Bar(B) into the Side Panel(A).

**Step 5**

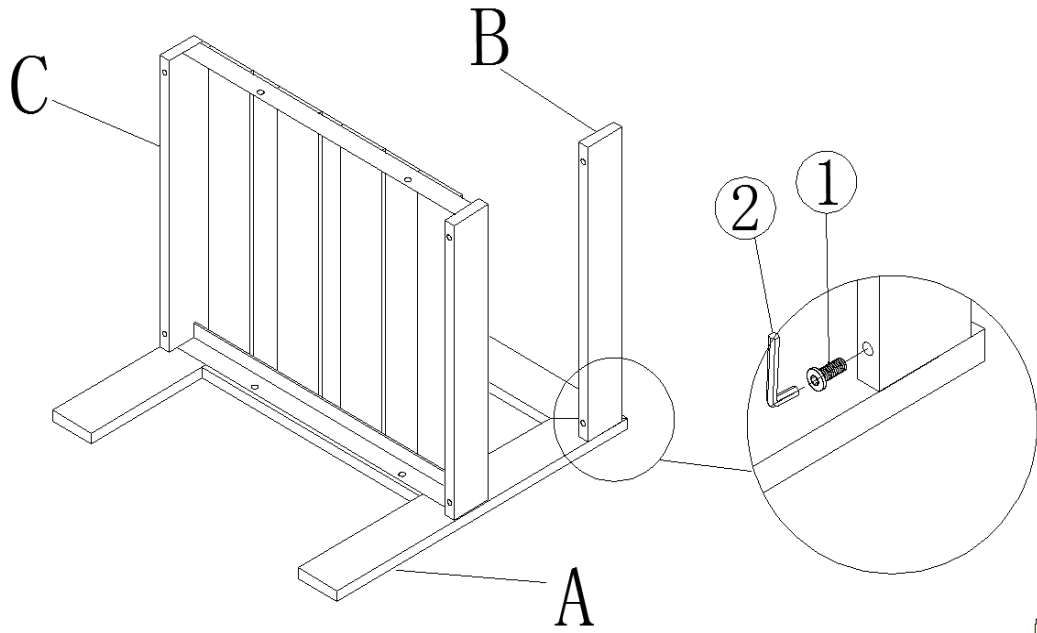

Attach the Back Support Bar(B) to the Side Panel(A) using Bolt(①) with Allen Key(②).  
**Do not fully tighten Bolts.**

**Step 6**

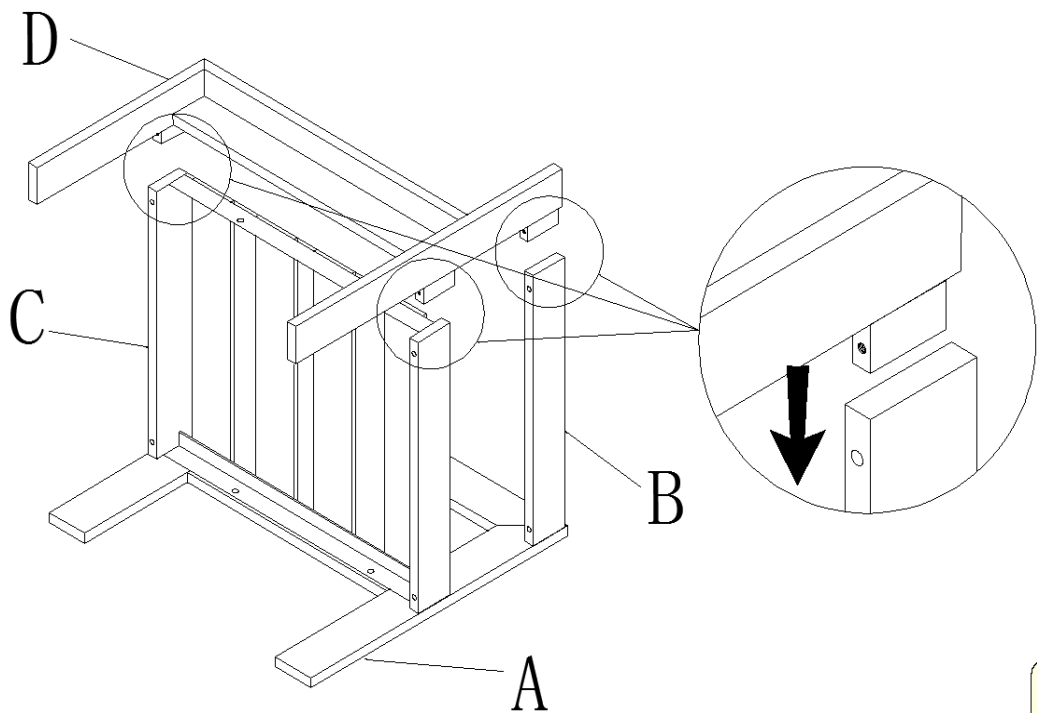

Insert the Leg Support Bar(D) into the Back Support Bar(B) and Seat Panel(C) as shown above.

## Step 7

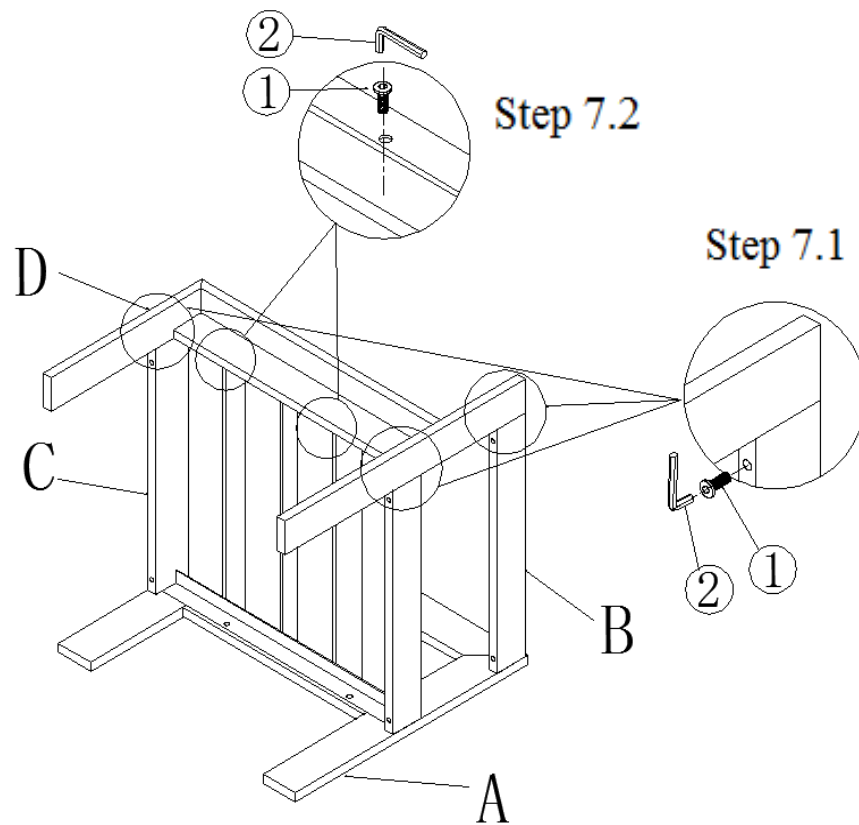

**7.1)** Attach the Leg Support Bar(D) to Back Support Bar(B) and Seat Panel(C) using Bolts(①) with Allen Key(②) as shown above.

**7.2)** Attach the Leg Support Bar(D) to Back Support Bar(B) using Bolts(①) with Allen Key(②) as shown above.

**Do not fully tighten Bolts.**

## Step 8

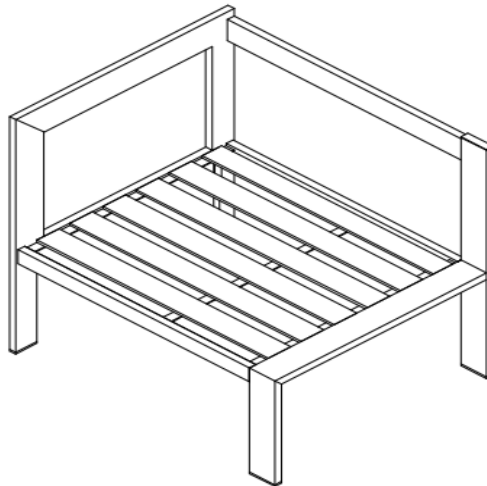

Stand the Sofa Corner up.  
Place the Sofa Corner on a LEVEL SURFACE.  
Inspect it and make sure all parts are adequately connected.  
Gently and carefully, sit onto the Sofa Corner.  
This will help to align all the parts at all joints.  
Then get off the Sofa Corner, and in a sequential manner, proceed to tighten all Bolts.

**When tightening the Bolts, tighten sequentially.**  
**DO NOT tighten any Bolt fully and then move on to the next one.**  
**This may cause the frame to warp.**  
**If there are still wobbles, loosen the Bolts and execute the same process.**  
**If the Sofa is not stable it could lead to damage to the product.**





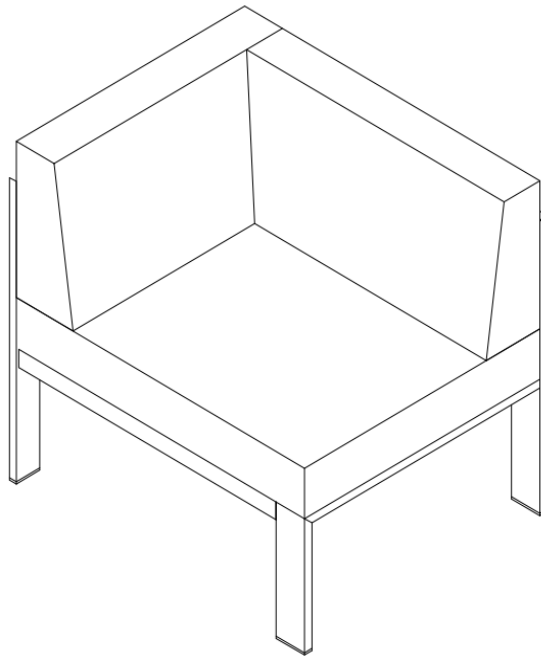













**Note: This step is done best with the assistance of a second adult.**

## Step 9



Put Seat Cushion(E) and Back Cushions(F) on the Sofa, and stick the vercro.  
Your Sofa Corner is ready for use.

## Care & Maintenance

-   • Do not put hot items directly on furniture surface.
  -   • Do not clean furniture with harsh cleansers or polish.
  -   • To obtain the longest lifespan of your outdoor products, minimizing exposure to direct sunlight is recommended.
  -   • Children should not climb or jump on the furniture.
  -   • Do not write on furniture without a padded barrier to protect the surface.
  -   • To obtain the longest lifespan of your outdoor products, avoid extended and lengthy exposure to rain, snow, and direct sunshine. Whenever possible cover the product and /or place under patio or awnings.
  -   • Not for commercial use. For residential use only .
  -   • Stains may be removed with mild soap solution and damp cloth.
- 
-   • Dust and pick-up spills using a clean, non-colored, lint-free cloth .

### What Is Proposition 65?

Proposition 65 is a California law that requires warning labels on products that may contain one of more than 800-plus chemicals or ingredients that the California Office of Environmental Health Hazard Assessment (OEHHA) has deemed to cause cancer or other reproductive toxicity. Chemicals and elements on this list include wood dust, brass, and other everyday substances, which can be found in very common household items, such as: lamps, tableware, jewelry, crystal glasses, electric cords, beauty products, automobiles, and furniture.

### Why Did I Find a Proposition 65 Warning on My Home Goods Product?