

ASSEMBLY INSTRUCTION

SKU: WF318668

WF318670

WF318671



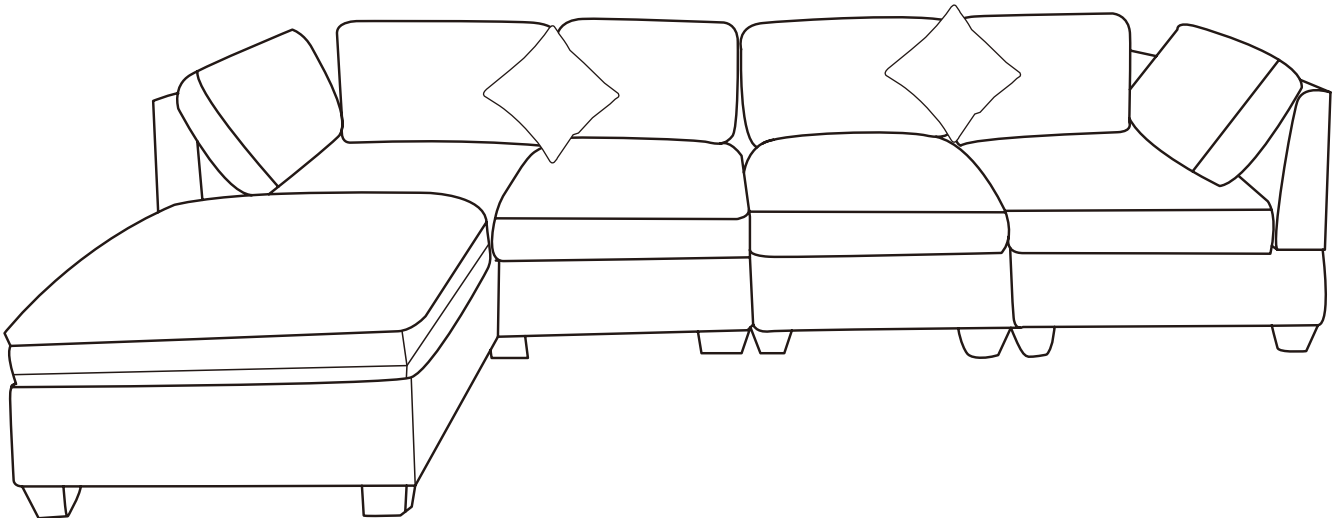

WF318672

WF318673



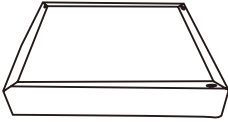
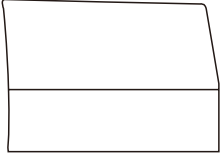
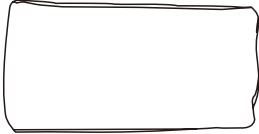

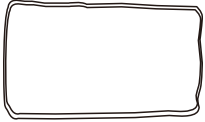
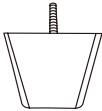

PACKING DETAILS: TOTAL 5 BOXS

BOX-1/5

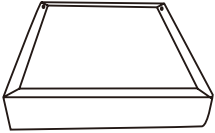

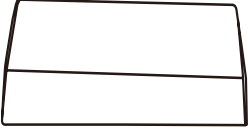
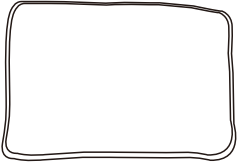
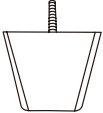

NO.	PARTS	QTY
A		1
I		1
M		1
F		1
O		1
Q		4
R		12
S		4

BOX-2/5



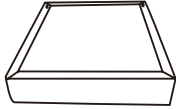

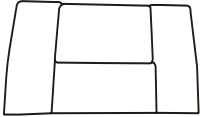
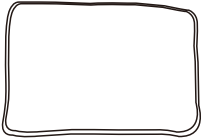
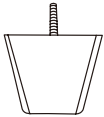
NO.	PARTS	QTY
B		1
K		2
G		1
N		1
Q		4
S		4

PACKING DETAILS: TOTAL 5 BOXS

BOX-3/5

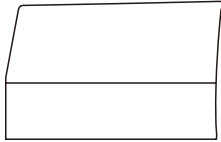
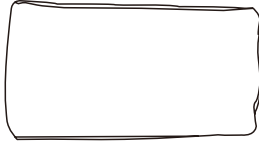

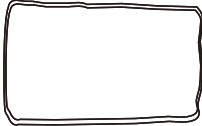
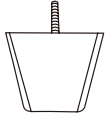

NO.	PARTS	QTY
C		1
K		2
H		1
N		1
Q		4
S		4

BOX-4/5

NO.	PARTS	QTY
D		1
J		1
M		1
F		1
O		1
Q		4
S		4

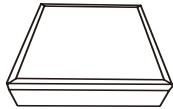
PACKING DETAILS: TOTAL 5 BOXS

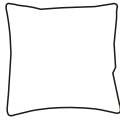
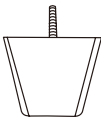
BOX-5/5

NO.	PARTS	QTY
E		1
L		1
P		2
Q		4
S		4

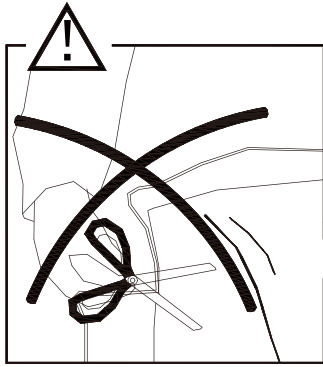
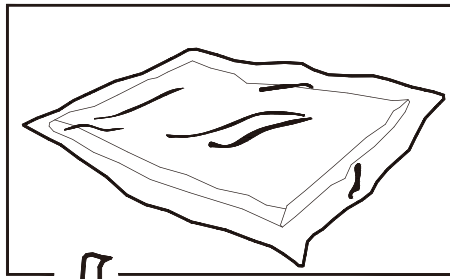

EN The wrinkles on the cushion can be ironed with a steam iron, or after 72 hours, the wrinkles will disappear slowly.

FR Les plis sur le coussin peuvent être repassés à l'aide d'un fer à vapeur, ou après 72 heures, les plis disparaîtront lentement.

DE Die Falten auf dem Kissen können mit einem Dampfbügeleisen gebügelt werden, oder nach 72 Stunden, werden die Falten langsam verschwinden.

ES Las arrugas del cojín se pueden planchar con una plancha de vapor, o desaparecerán lentamente después de 72 horas.

PT Pode-se passar as almofadas para remover o amassado usando ferro a vapor ou, após 72 horas, o amassado desaparece lentamente.

IT Le pieghe sul cuscino possono essere stirate con un ferro da stiro a vapore, oppure dopo 72 ore le pieghe scompariranno lentamente.

EN Make the backrest pillows fuller by tapping and squeezing them.

FR Rendez les coussins du dossier davantage pleins en les tapotant et en les pressant.

DE Die Kissen der Rückenlehne werden durch Klopfen und Zusammendrücken fülliger.

ES Hágalos más llenos golpeando y apretando los cojines del respaldo.

PT Bata e aperte as almofadas do encosto para deixá-las mais cheias.

IT Rendere i cuscini del supporto schienale più pieni battendoli e stringendoli.

A x 1	B x 1	C x 1	D x 1
E x 1	F x 2	G x 1	H x 1
I x 1	J x 1	K x 4	L x 1
M x 2	N x 2	O x 2	P x 2
Q x 20	R x 12	S x 20	

A x 1	B x 1	K x 2	I x 1	M x 1
--------------	--------------	--------------	--------------	--------------

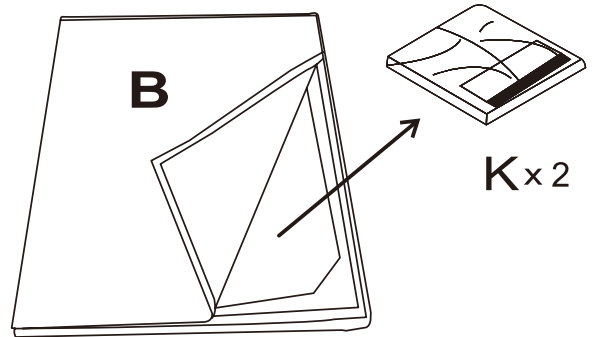
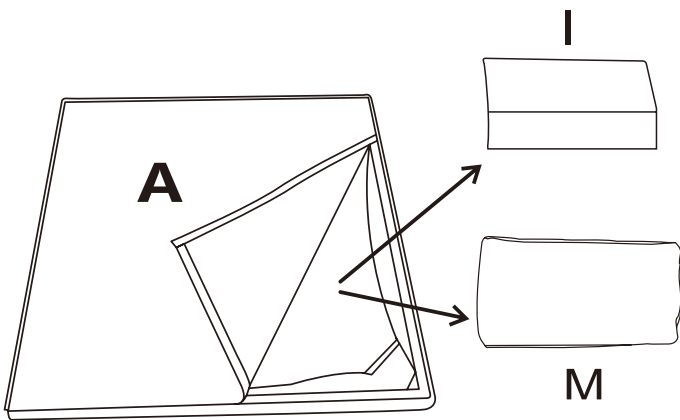

Cx1

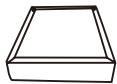

Dx1

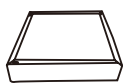

Jx1

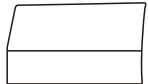

Mx2



Kx2

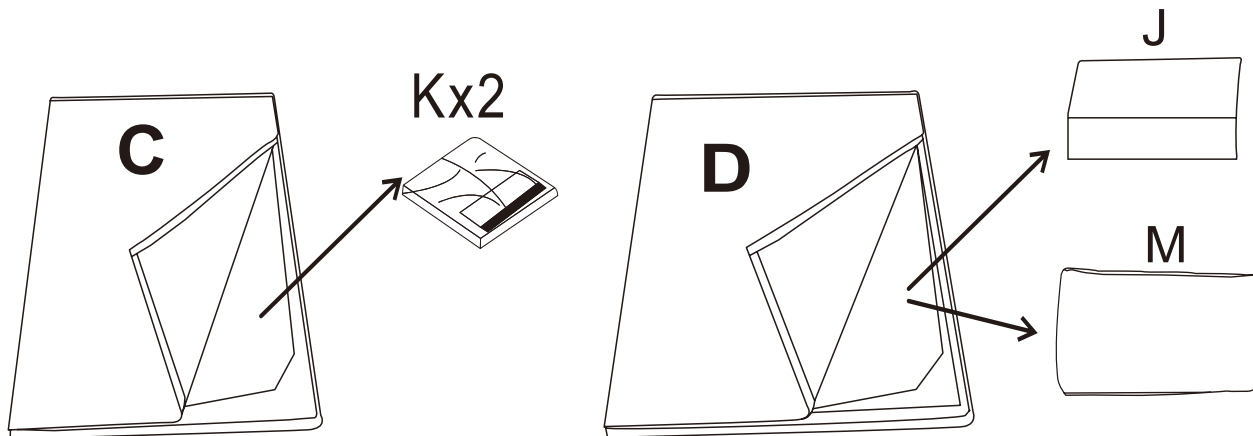

Ex1

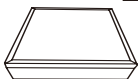

Px2



Qx4



Lx1

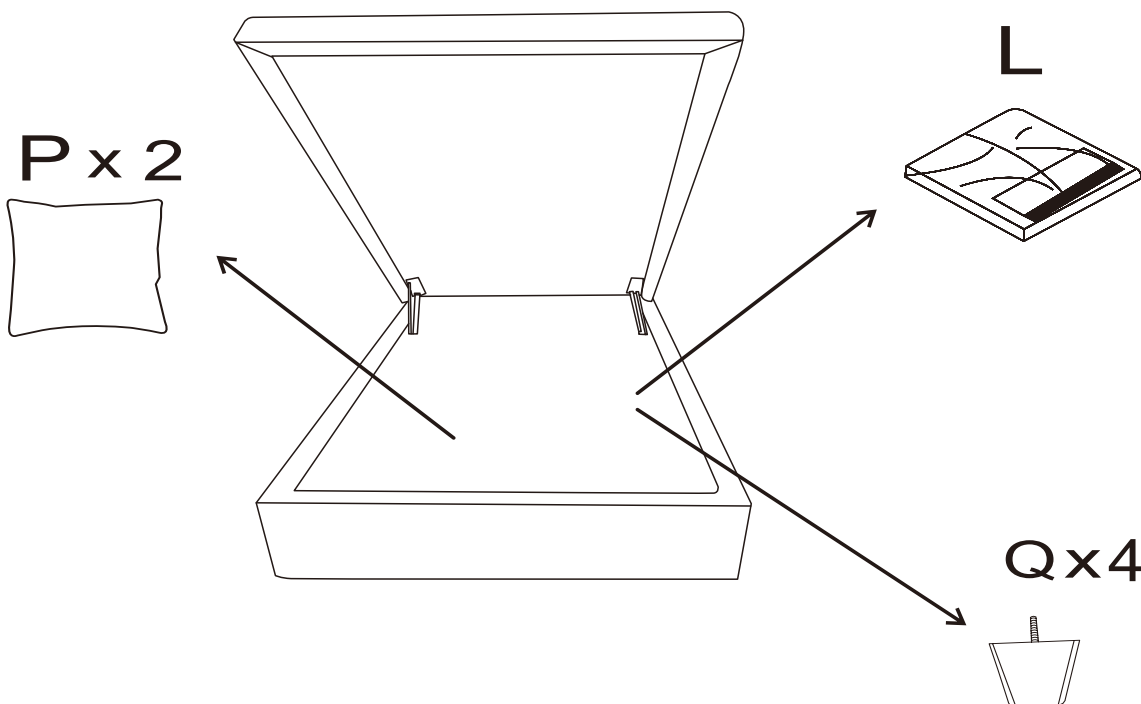

A x 1

B x 1

C x 1

D x 1

Q x 20

E x 1

S x 20

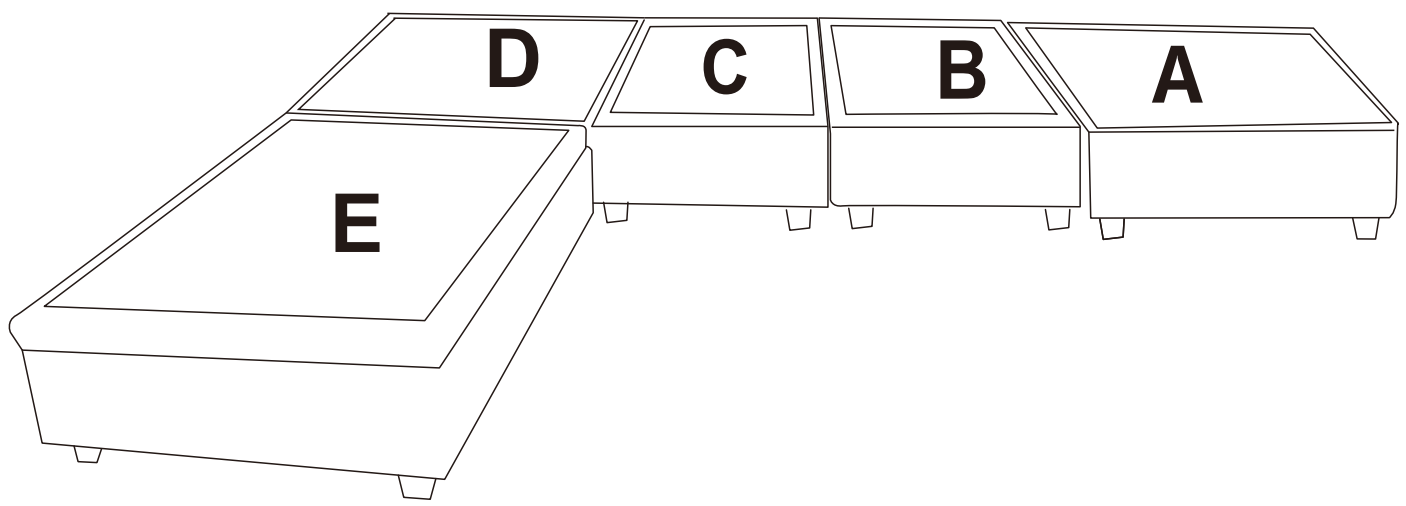
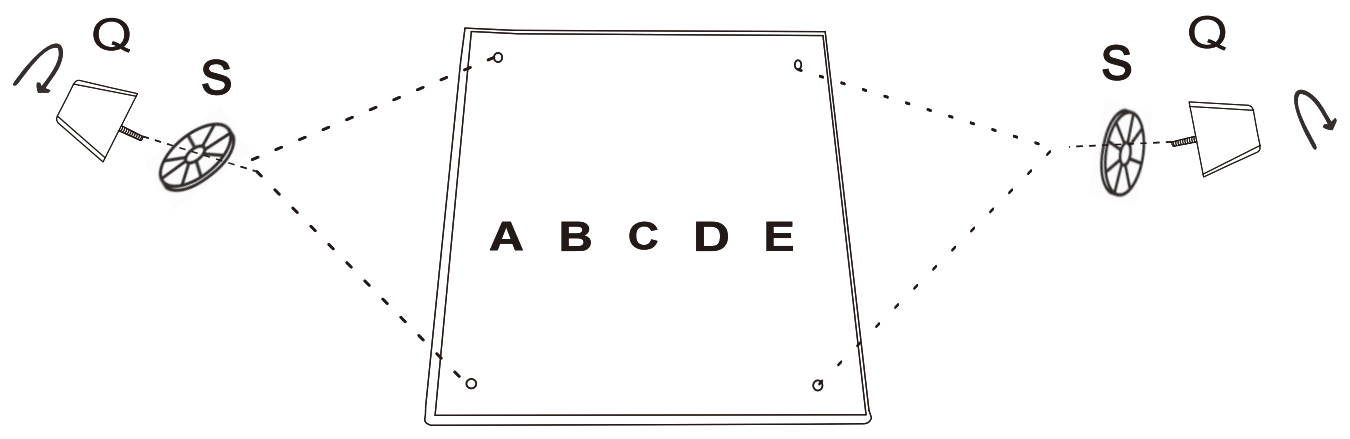
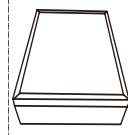
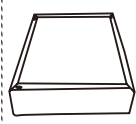
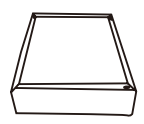

A x 1

B x 1

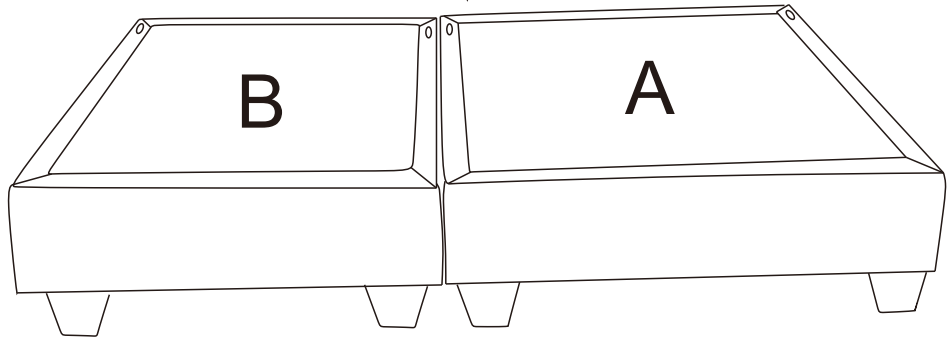
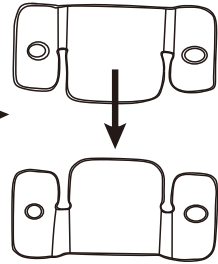
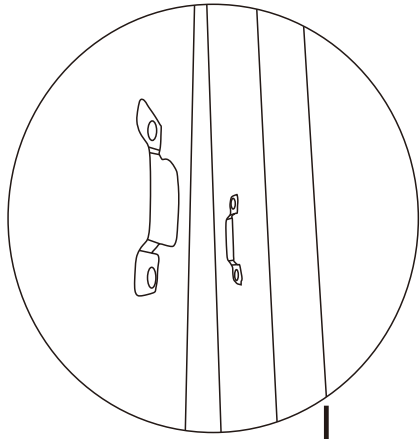
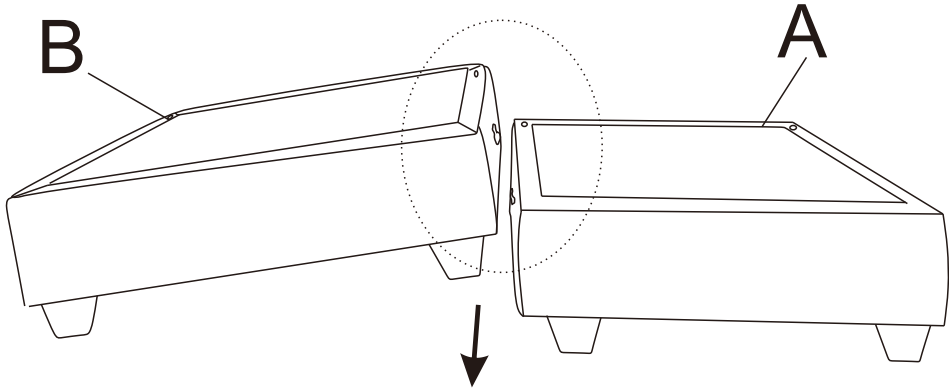
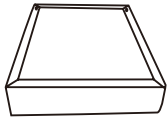
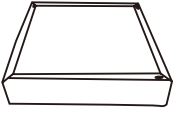

A x 1

B x 1

C x 1

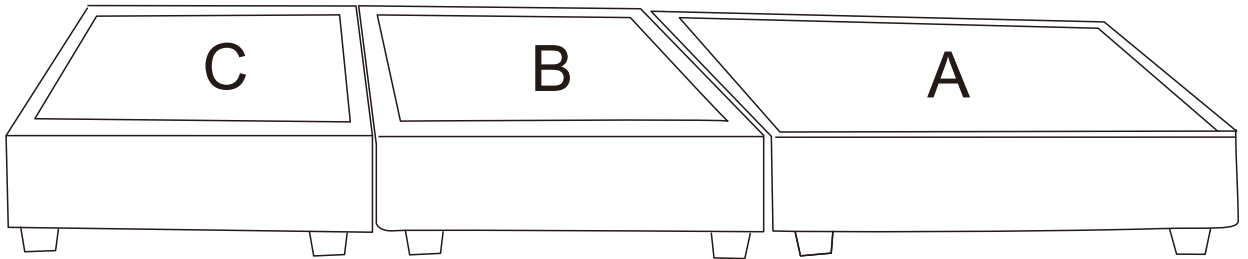
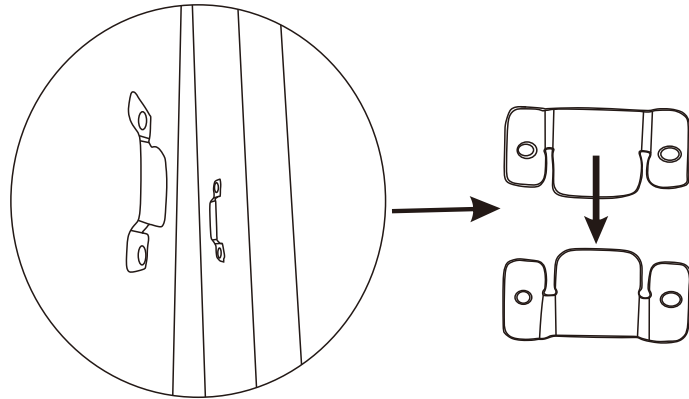
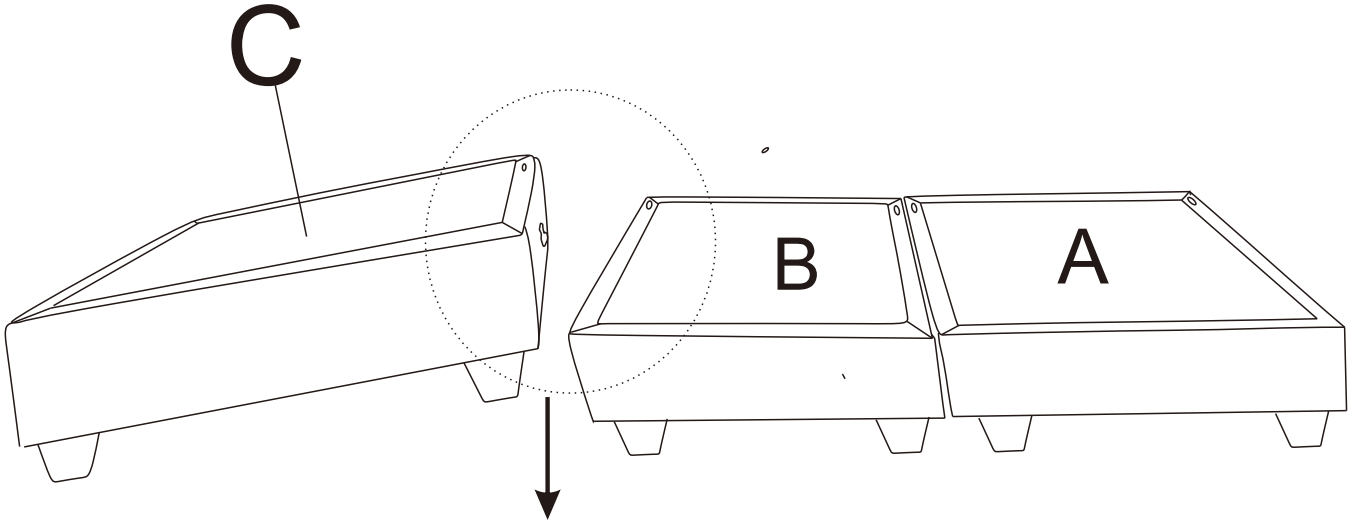
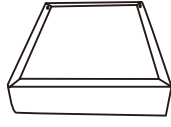
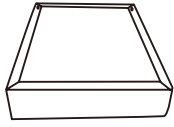
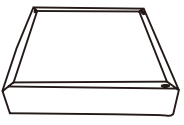

A x 1

B x 1

C x 1

D x 1

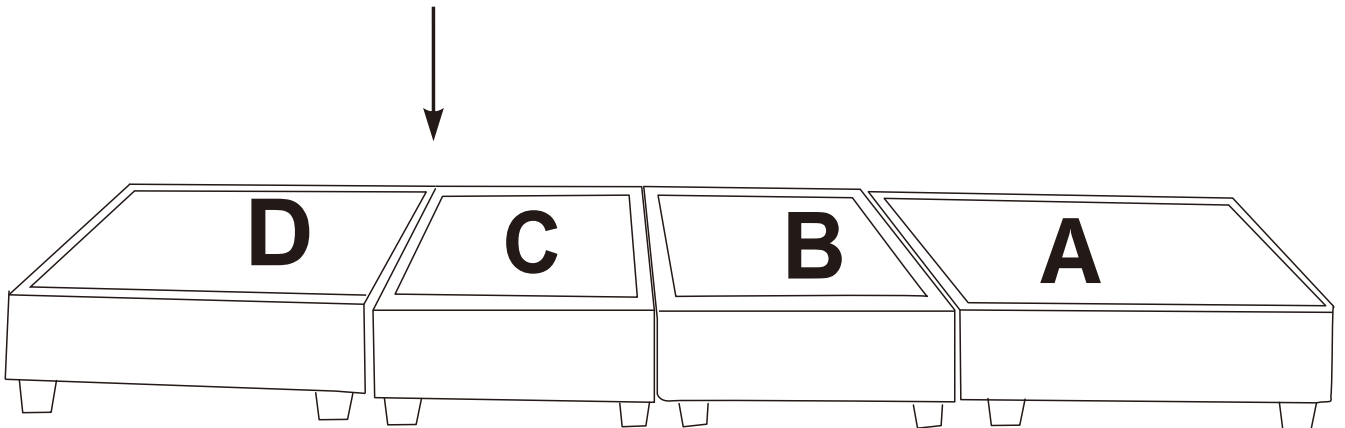
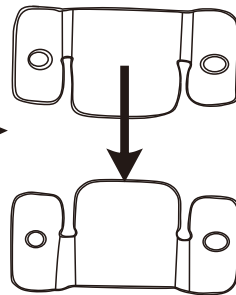
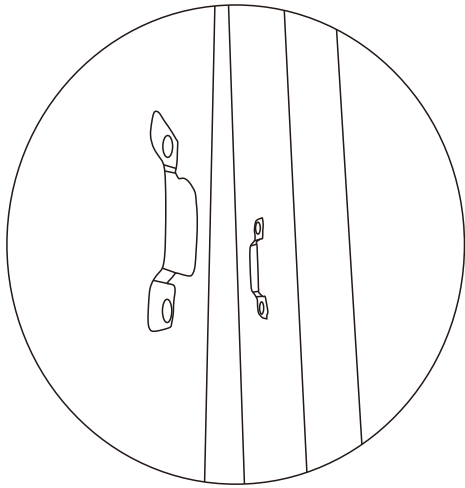
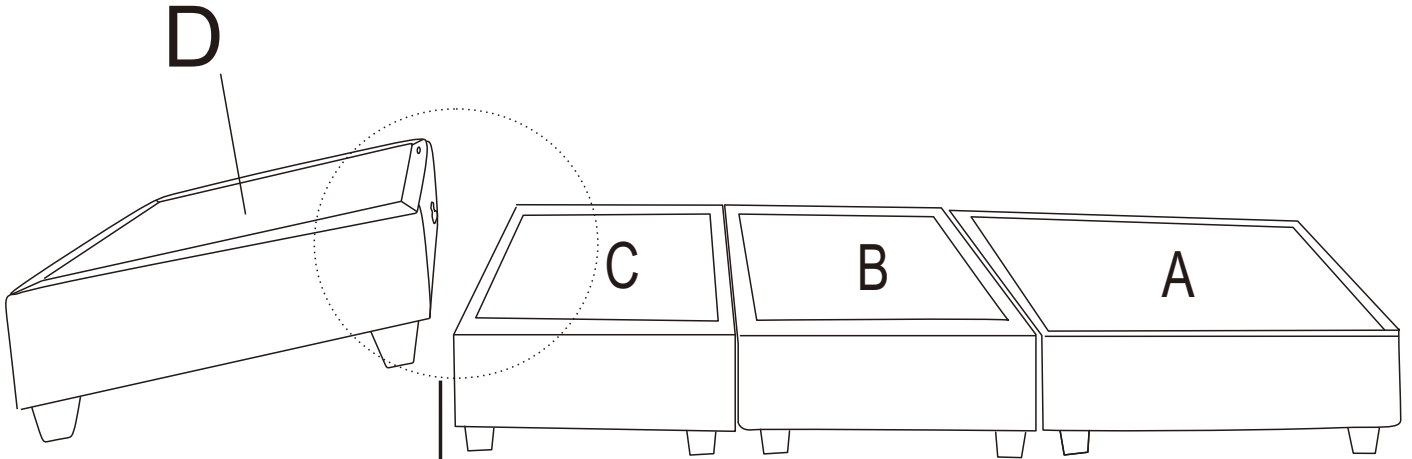
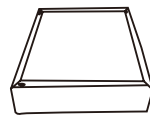
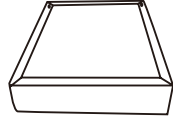
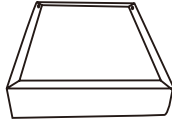
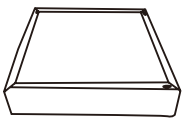

Rx12

Gx1

Fx2

Hx1

Jx1

Ix1



I

Rx2

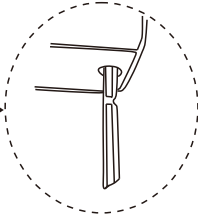
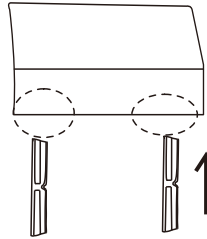

J

Rx2

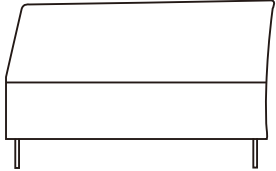
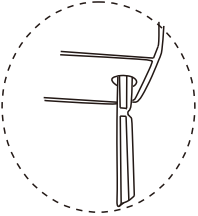
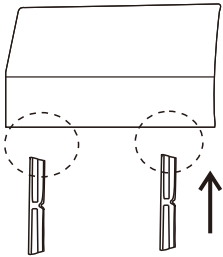

H

Rx2

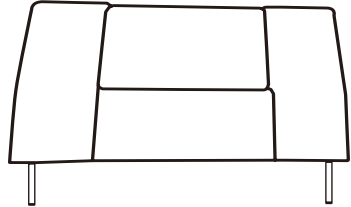
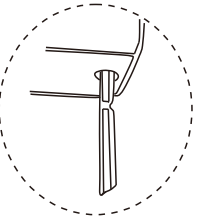
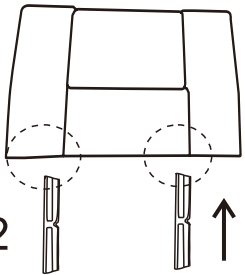

Fx2

Rx4

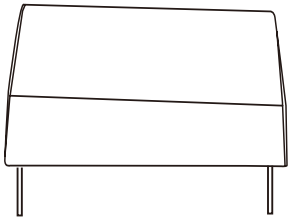
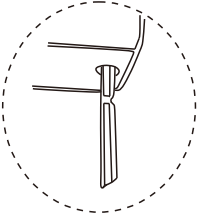
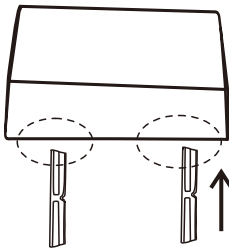

G

Rx2

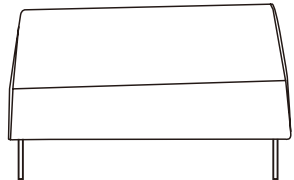
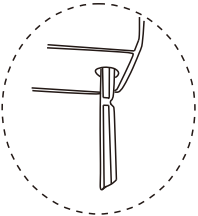
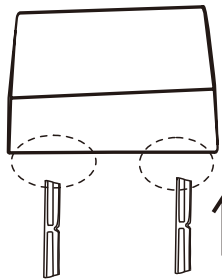

I x1

F x

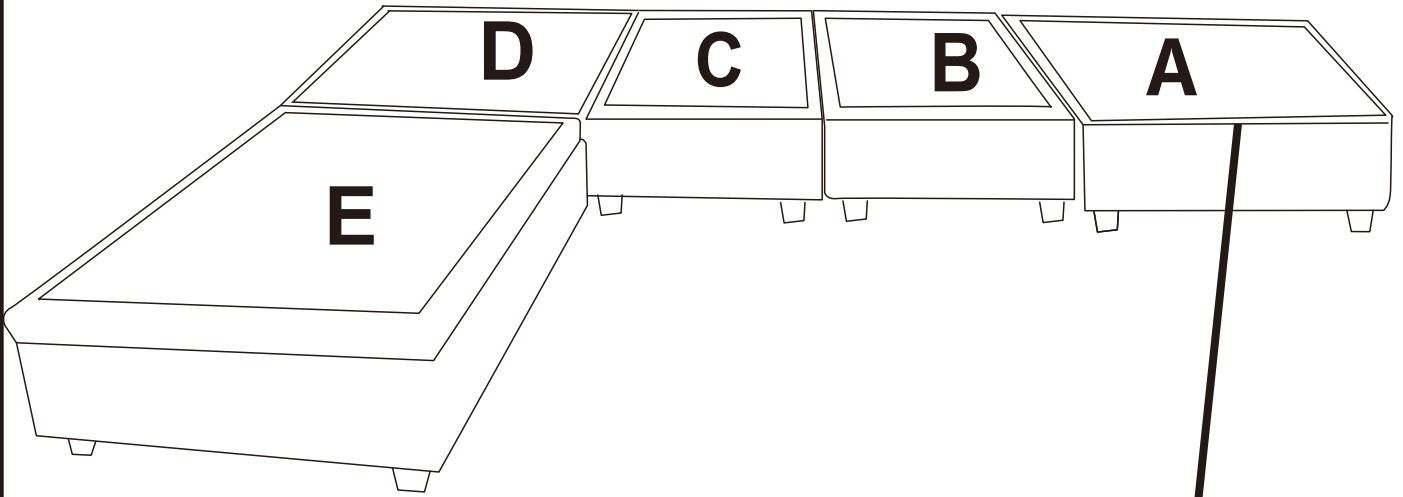
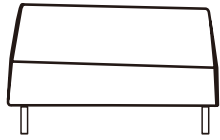
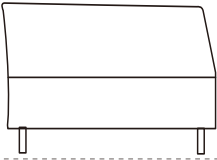

F

I

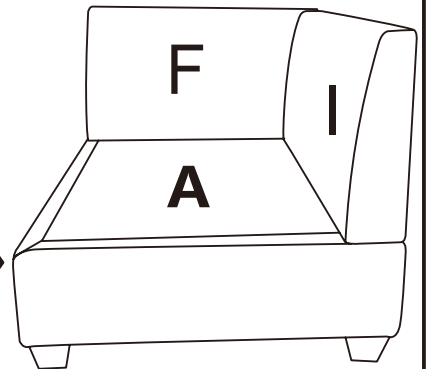
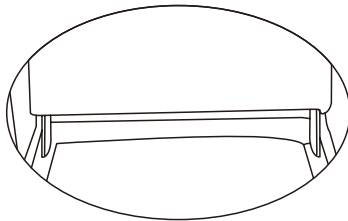
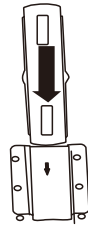
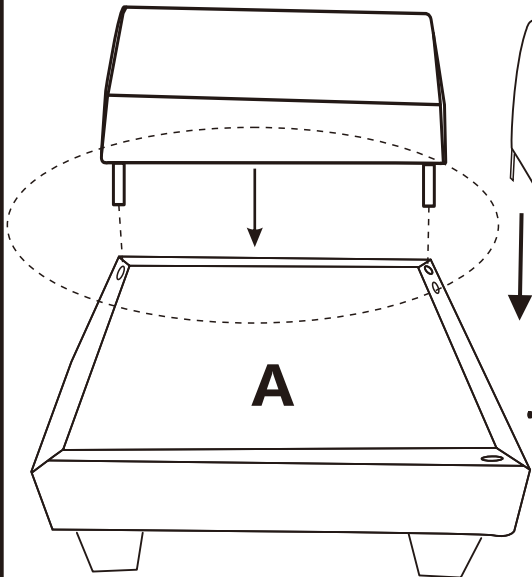

G x1

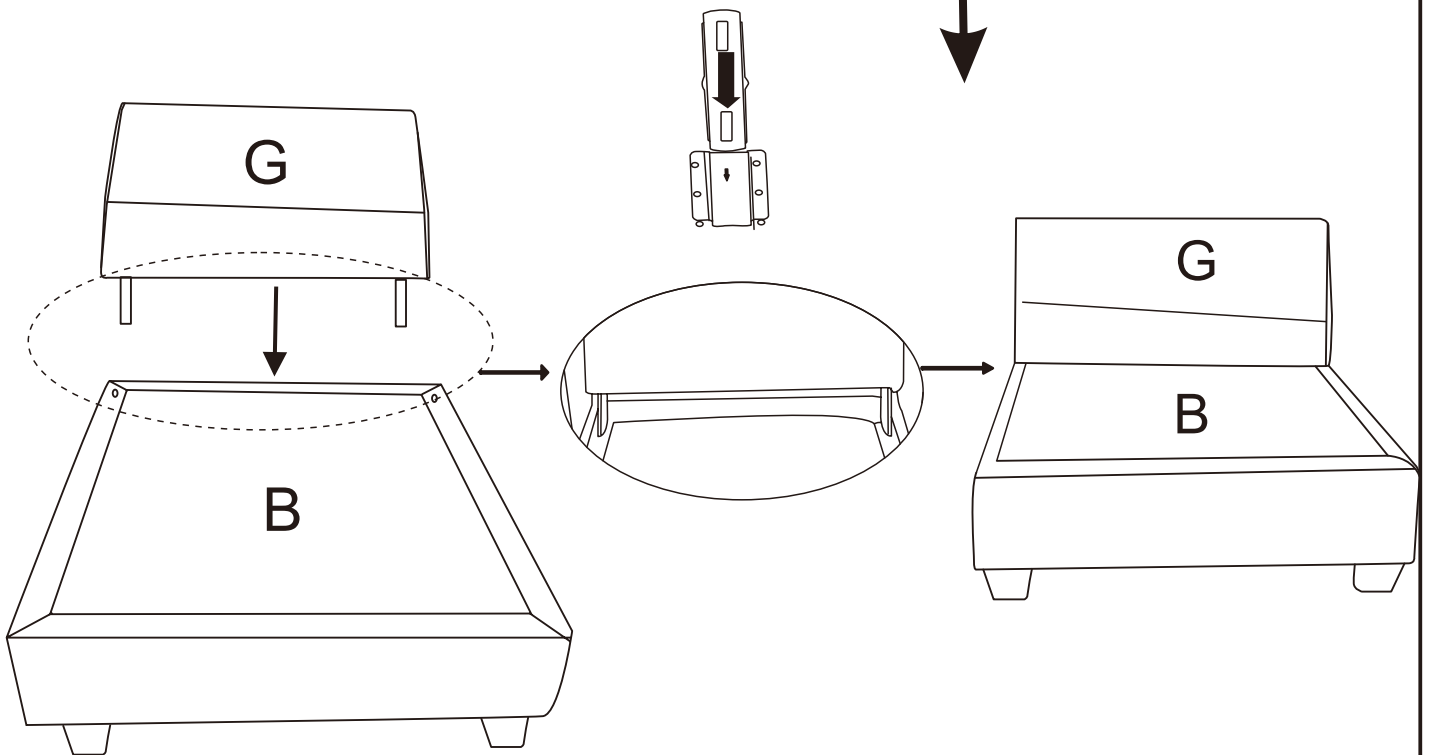
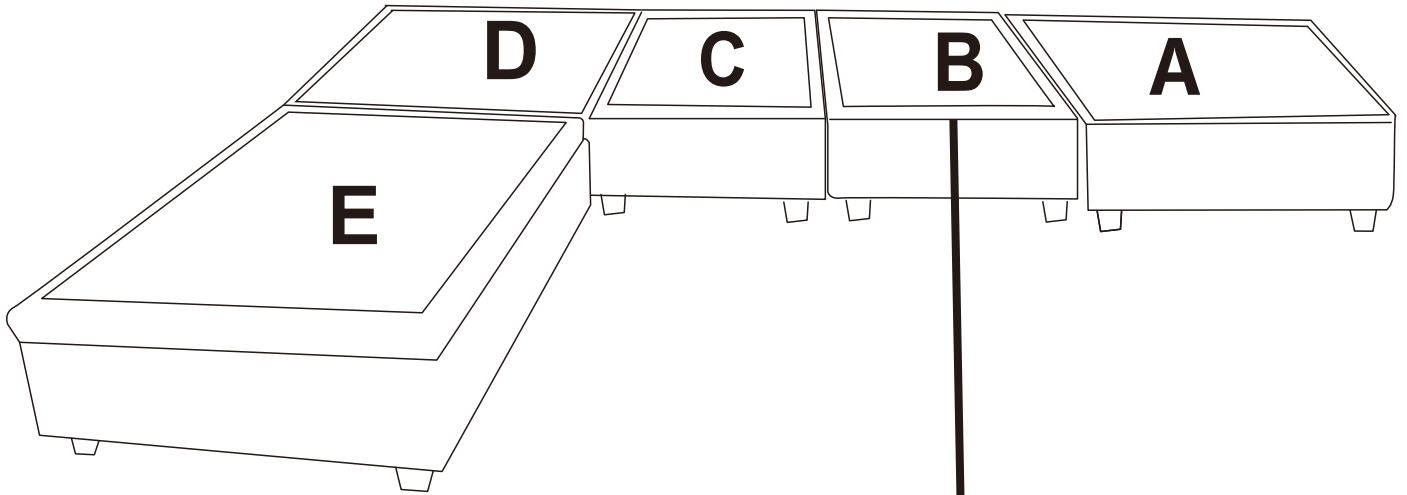
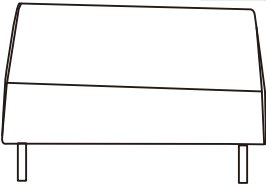

H x 1

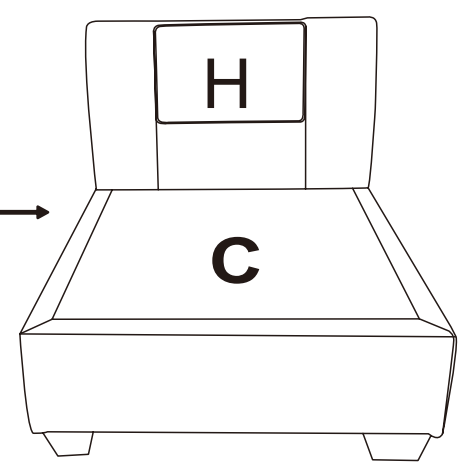
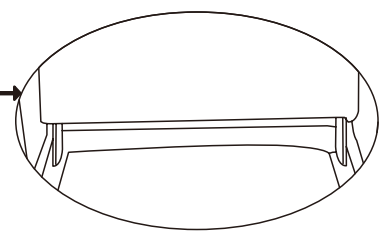
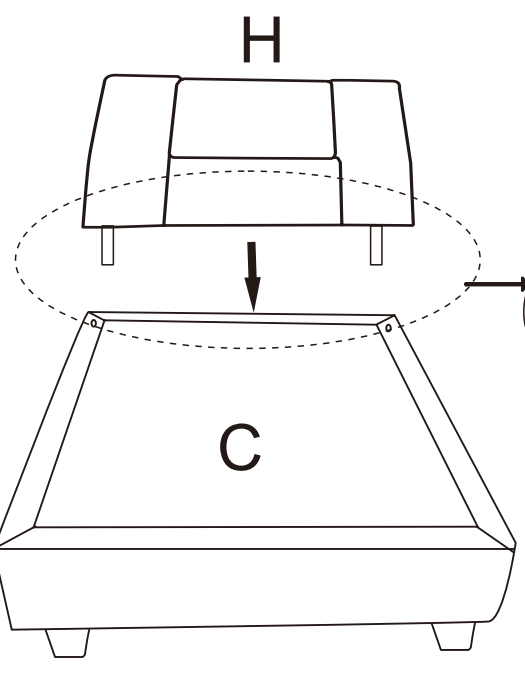
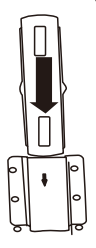
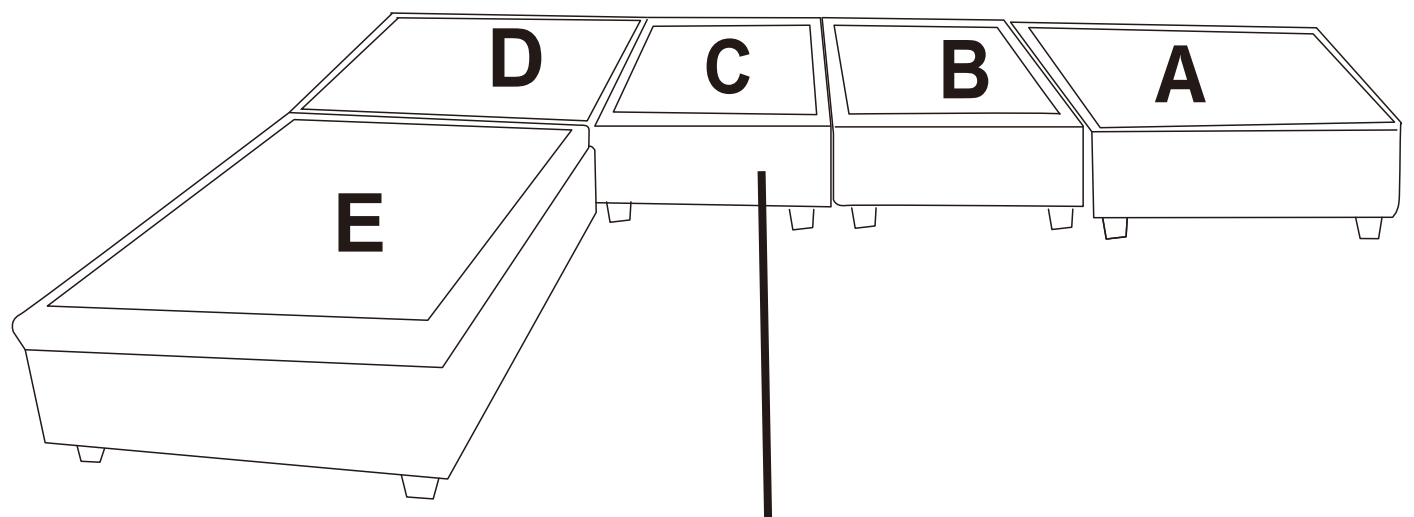
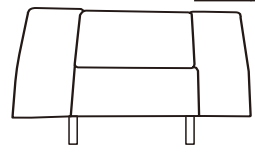

F x1

J x1

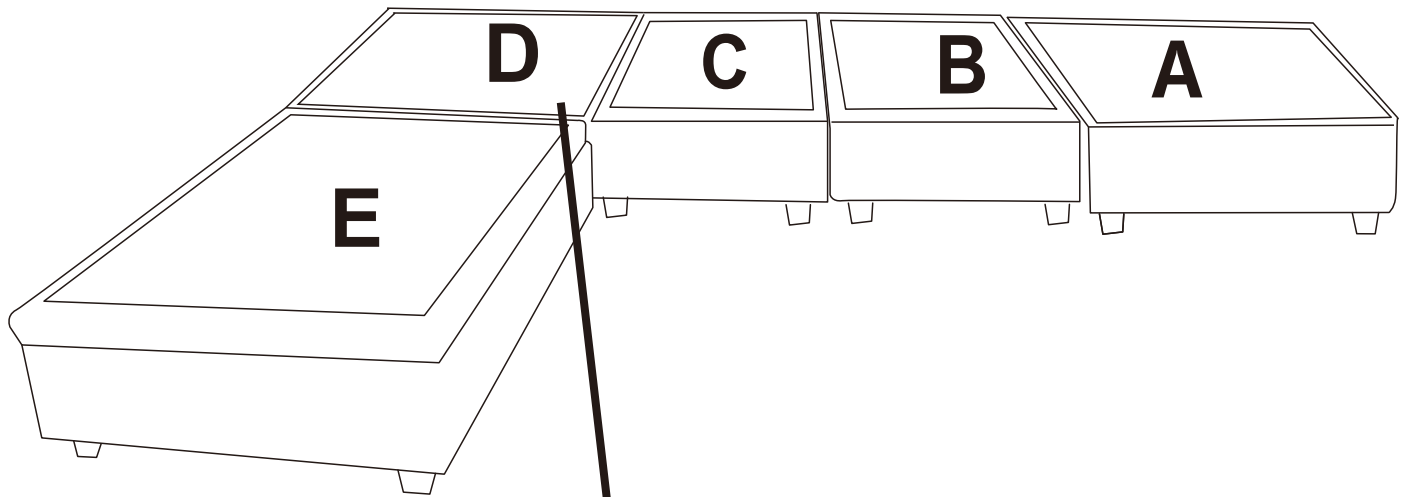
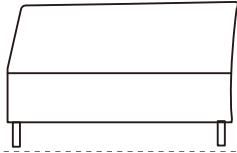
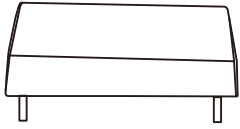

J

F

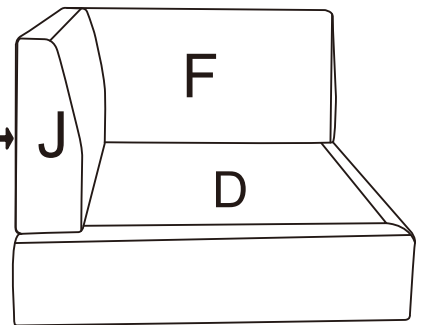
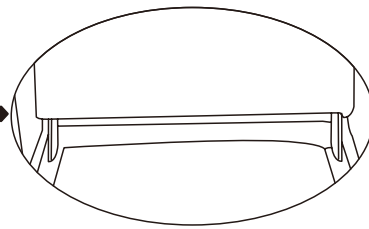
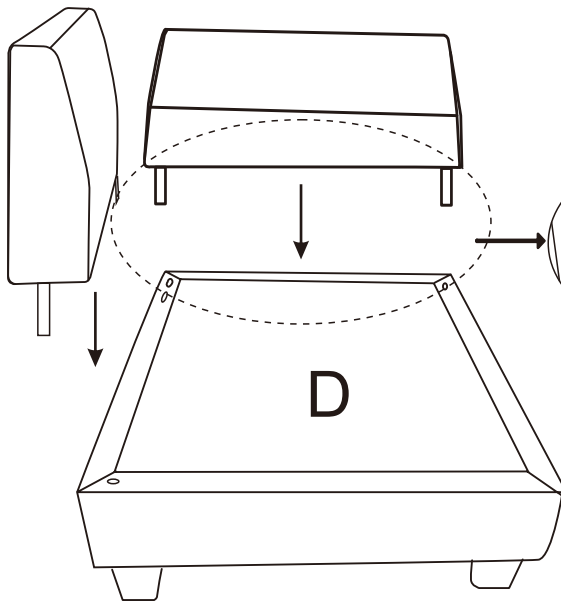
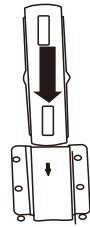

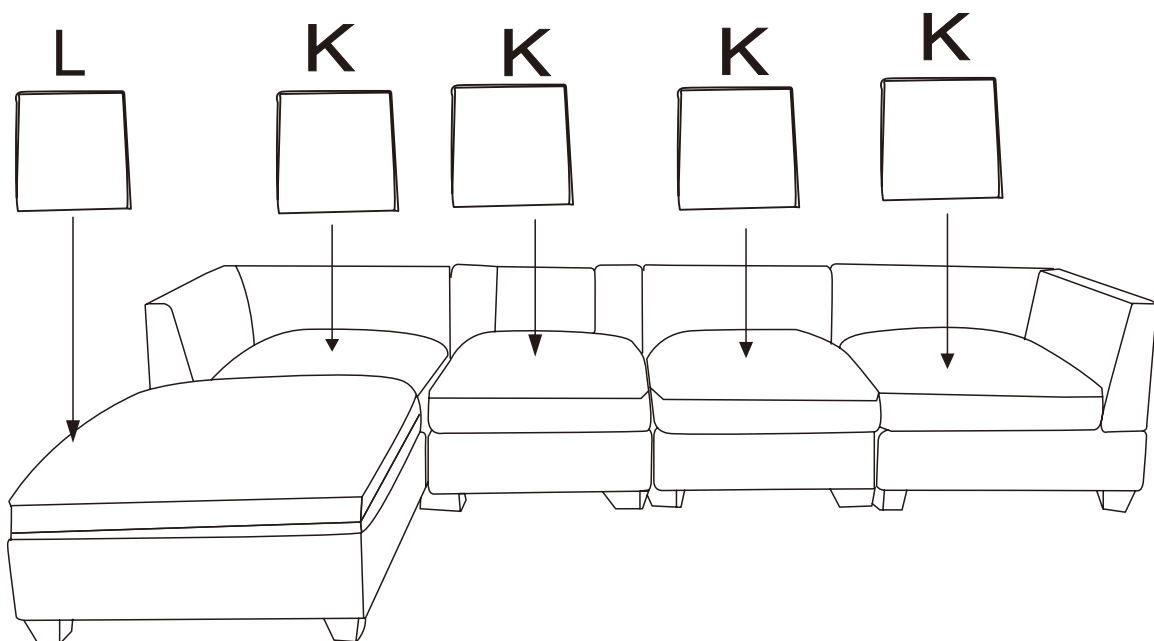
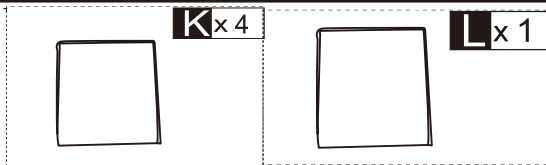
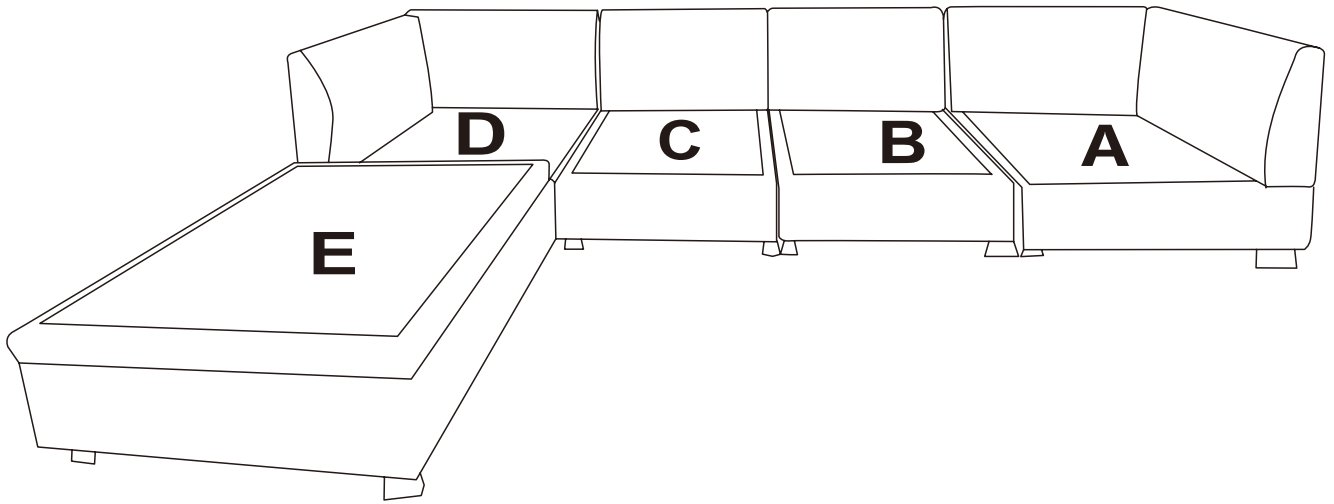

Nx2

Ox2

Mx2

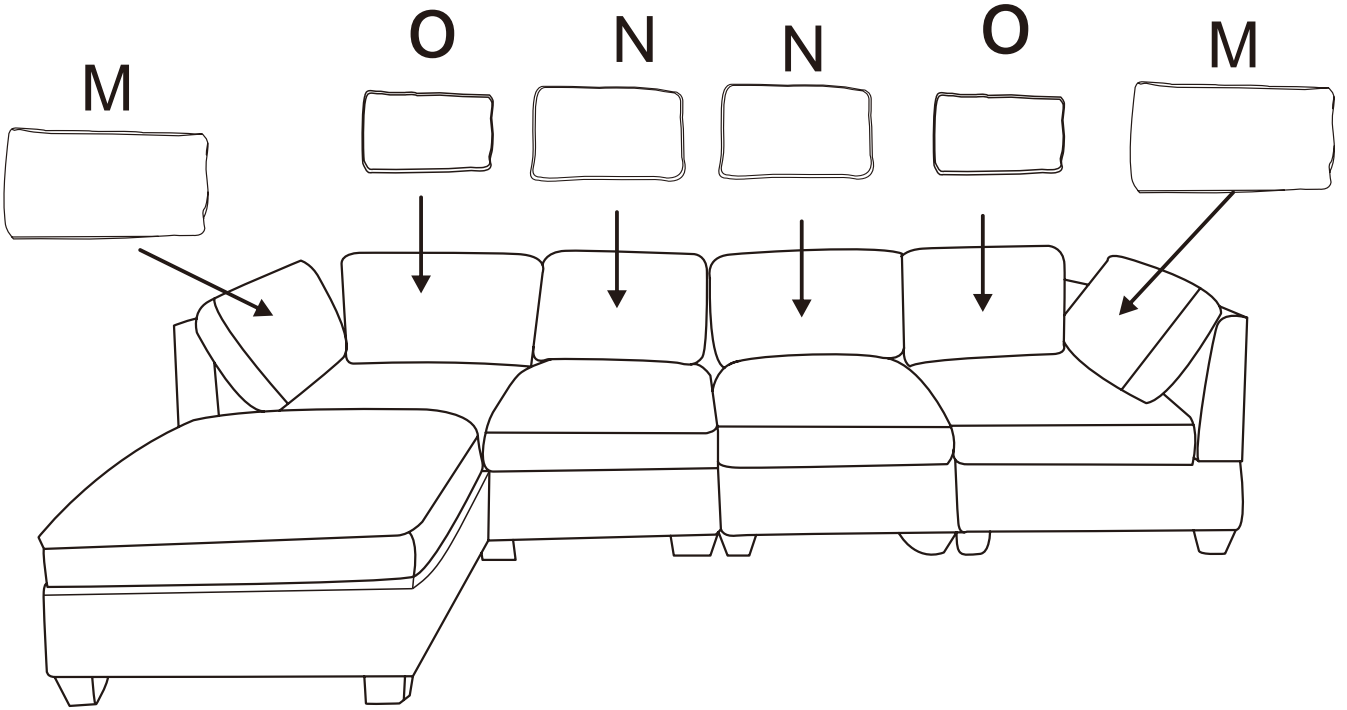
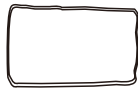

Px2

