

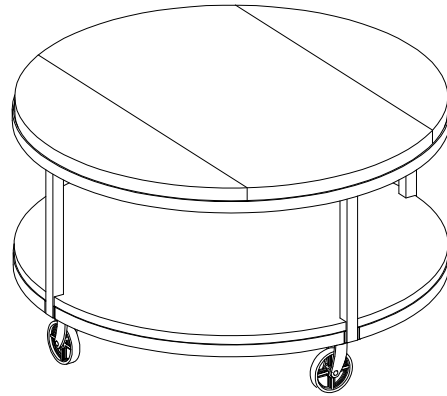









ASSEMBLY INSTRUCTIONS

990-911 ROUND COFFEE TABLE



| No. | Hardware List | Q'ty |
|-----|---|------|
| 1 |  M5/16" | 1pc |
| 2 |  Ø5/16 "x5/8 " | 8pcs |
| 3 |  Ø5/16" | 8pcs |
| 4 |  Ø5/16"*19mm | 8pcs |
| 5 |  10mm | 4pcs |
| 6 |  14mm | 1pc |

| No. | Part List | Q'ty |
|-----|---|------|
| A |  | 1pc |
| B |  | 4pcs |
| C |  | 1pc |
| D |  | 4pcs |

1st Step:

Firstly ,lay top(A) face-down on a clear and smooth surface.

Then attach leg(B) to top(A) with flat washer(4), Lock washer(3),allen head bolt(2) **through** the square tube in top(A). Use allen wrench(1) to tighten the bolts, Don't **too** fully tighten. As in shown.

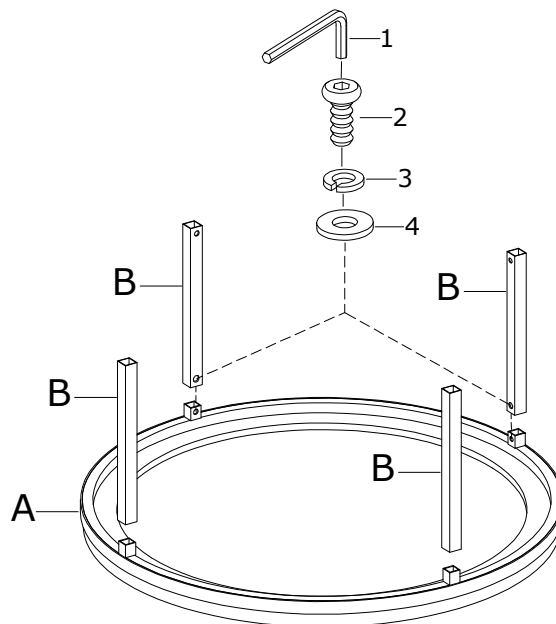

2nd Step:

Attach the shelf (C) to leg (B) using Bolt (2), lock washer (3) and flat washer (4), tighten bolts with allen wrench (1). Finally, tighten fully all bolts.
As in shown.

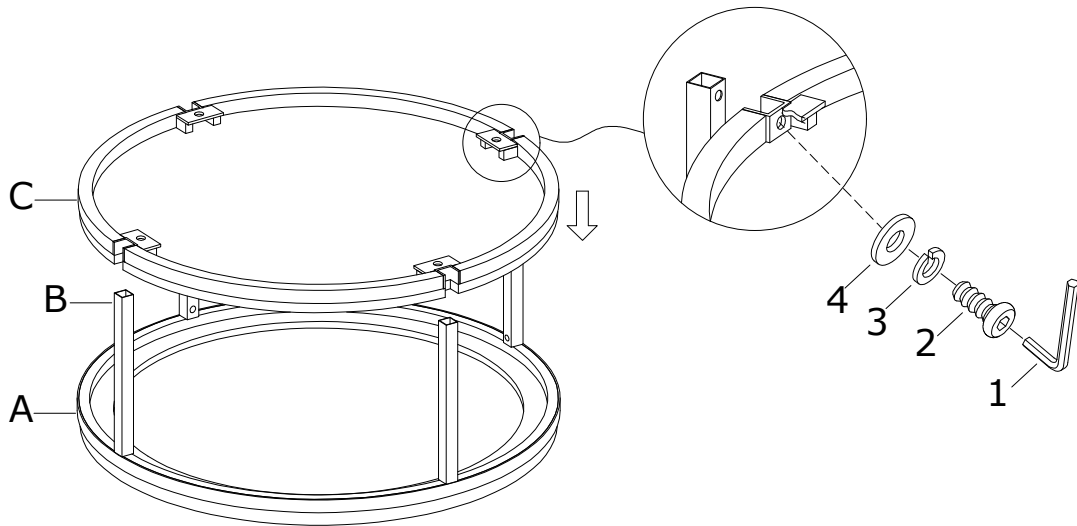

3rd Step:

Place caster (D) spring washer (5) into shelf (C) through inserting into the screw hole in shelf (C) and use open outer hex wrench (6) to fully tighten.
As in shown.
Finally, turn the assembly table upright position.

