

ASSEMBLY INSTRUCTIONS

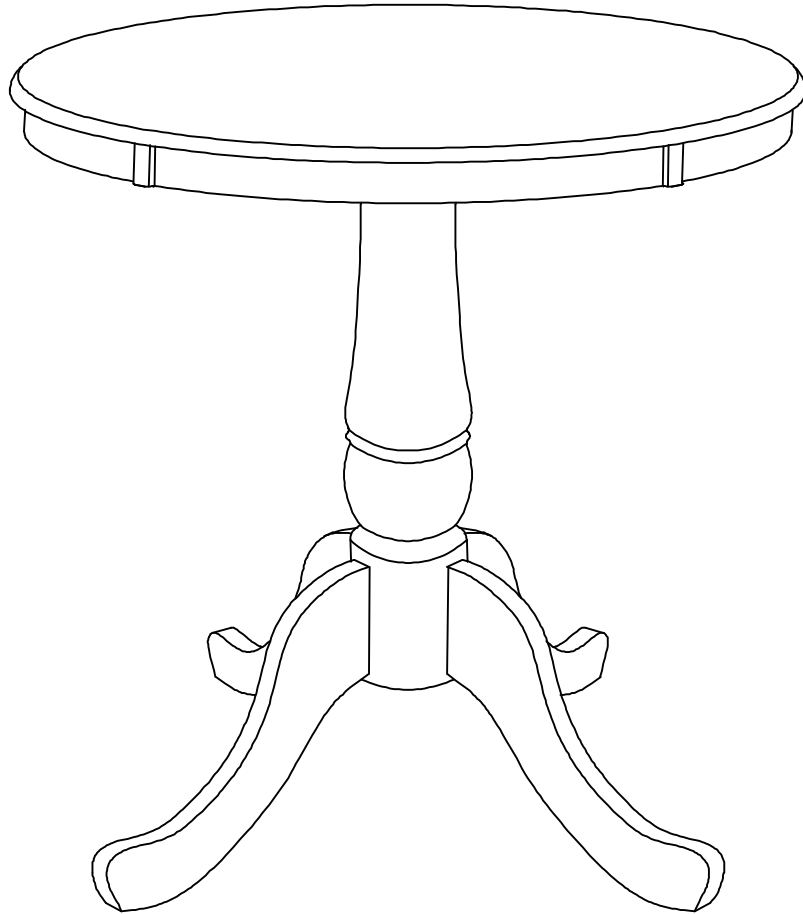

Description	: DINING PEDESTAL
-------------	-------------------

BEFORE ASSEMBLY

Thank you for purchasing this quality product. This product has been designed for easy assembly and constructed for durability. Please take the time to read and follow the assembly instructions carefully.

Be sure to check all packing material carefully for small parts which may have come loose inside the carton during shipment. Please separate, identify, and count all parts and metal hardware. Compare with part list to be sure all parts are present.

IMPORTANT NOTE:

- Place all wooden parts on a clean and smooth surface such as a rug or carpet to avoid the parts from being scratched.
- Remove all wrapping material, including staples & packing straps before you start to assemble.
- DO NOT tighten all screws and bolts until completely assembled.
- Keep all hardware parts out of reach of children.

PART LIST

When unpacking, please be careful not to discard any parts with the packaging. Before continuing, please make sure you have the following parts:

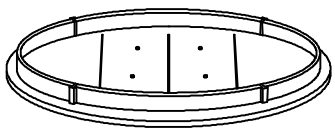
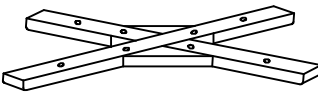



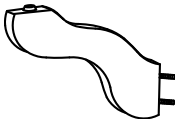
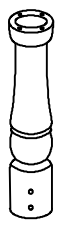

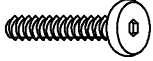

NO	Description	Qty	Sketch	NO	Description	Qty	Sketch
A	Top	1		B	Mounting Plate	1	

PART LIST

NO	Description	Qty	Sketch	NO	Description	Qty	Sketch
C	Leg	4		D	Pedestal column	1	

HARDWARE LIST

When unpacking, please be careful not to discard any parts with the packaging. Before continuing, please make sure you have all of the following hardware:

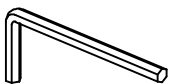
NO	Description	Qty	Sketch	NO	Description	Qty	Sketch
1	Bolt (M6x35mm)	8		2	Flat washer (Φ6.5x13mm)	4	
3	Flat washer (Φ6.5x19mm)	4		4	Lock washer (Φ6.5x11mm)	8	
5	Flat washer (Φ8.5x19mm)	4		6	Lock washer (Φ8.5x13mm)	4	
7	Hexagon nut (M8)	4		8	Wrench (M13mm)	1	
9	Allen key (4mm)	1					

STEP 1

Attach legs (C) to column (D) by using nuts (7), and washers (6) and (5). Tighten with wrench (8) as shown below.

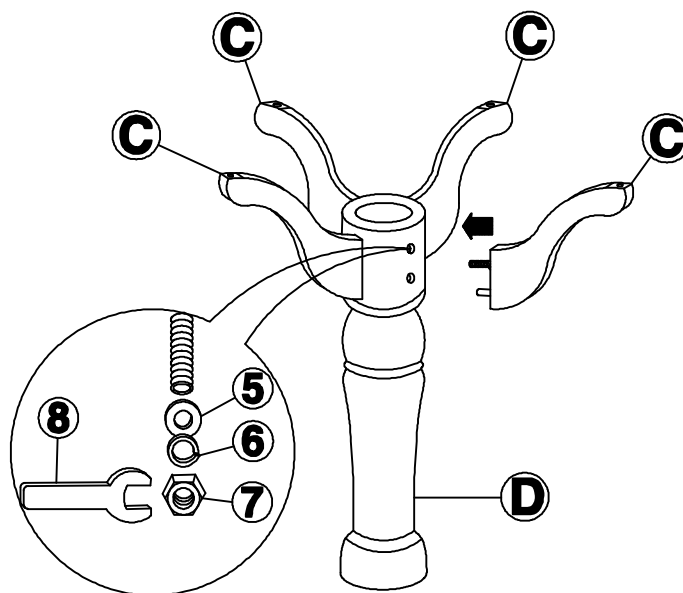

STEP 2

Place the mounting plate (B) of the column (D), with bolts (1), washers (2) and (4) as shown below. Tighten with allen key (9).

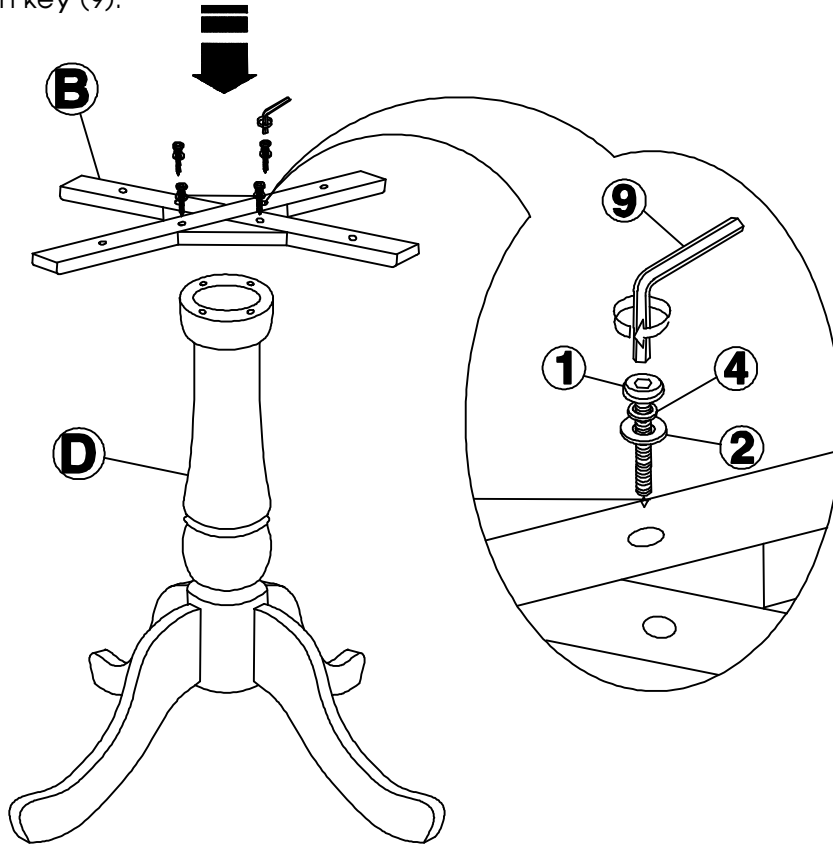

STEP 3

Carefully put the pedestal block on the bottom side of the table top, attach the top (A) to mounting plate (B) with bolts (1), washers (3) and (4) as shown below. Tighten with allen key (9).

