

# Assembly Instructions



## ASSEMBLY RATING

The Assembly Rating is a 5-point system that shows the degree of effort needed in assembling a specific product (with 1 being easy and 5 being difficult). For some products, two persons are recommended.

## Tools Required for Assembly:

Allen Wrench

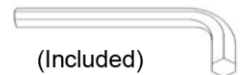

EASY DIFFICULT

The rating scale consists of five circles. The first three circles are solid black, and the last two are white with a black outline. This indicates a rating of 3 out of 5.

# ASSEMBLY & CARE ADVICE

FOR YOUR FURNITURE TO LAST, CORRECT ASSEMBLY AND PROPER MAINTENANCE ARE NECESSARY. PLEASE FOLLOW THE INFORMATION PROVIDED BELOW TO FULLY ENJOY YOUR FURNITURE.

## BASIC ASSEMBLY TECHNIQUES

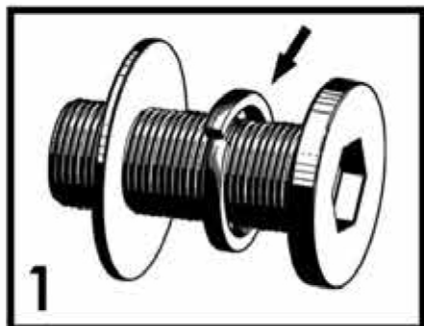

1 When lock or spring washer is used in an assembly, please make sure the lock or spring washer is placed between the larger flat washer and the head of the screw or bolt.

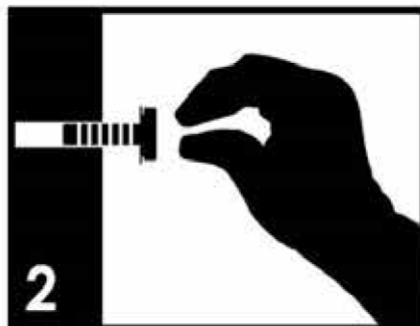

2 Position each part correctly and insert screws or bolts into their respective holes by hand tighten or using the proper hand tool. Only tighten when step is completed or when instructed to do so.

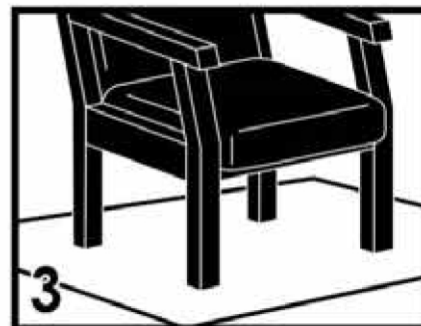

3 Use cardboard or carpet area when assembling furniture to prevent scratches. Make sure the furniture rests on a flat and level surface with each leg evenly touching the floor.

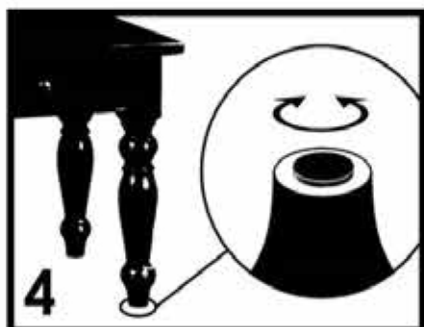

4 Some furniture comes with height adjustment knobs underneath each leg. To lower or to raise each leg, you need to turn clockwise or counterclockwise, respectively.

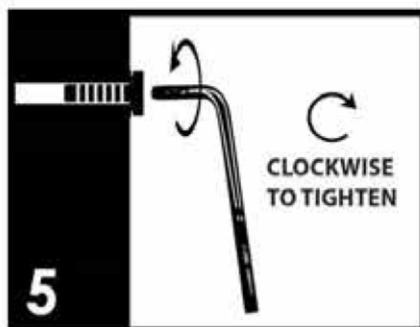

5 Make sure all parts are properly aligned, then use the appropriate hand tool to completely tighten the bolts or screws. Do not use power tools and do not overtighten.

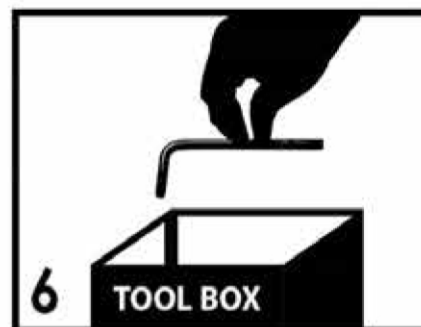

6 Save the instructions and store the Allen wrench or any supplied tool for later maintenance. After two weeks, check and tighten any loose hardware and repeat again every six months thereafter.

IT IS THE USER'S RESPONSIBILITY TO MAINTAIN THE FURNITURE. THE HARDWARE MAY LOOSEN OVER TIME AND MAY CAUSE THE FURNITURE TO BE WOBBLY AND UNABLE TO SUPPORT ITS INTENDED WEIGHT CAPACITY. THIS MAY LEAD TO COLLAPSE AND MAY CAUSE SERIOUS INJURY.



FAILURE TO FOLLOW THE GUIDELINES ABOVE MAY RESULT IN INJURY AND/OR PROPERTY DAMAGE.









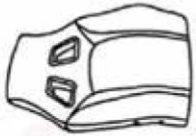

Before you begin, please read Page 2 of "Assembly and Care Advice".

And remember, do not tighten until each step is completed or instructed.

MD

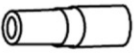



### Parts List

-  #1 x 1 pc  
Backrest
-  #2 x 1 pc  
Seat
-  #3R x 1 pc  
Right Armrest
-  #3L x 1 pc  
Left Armrest
-  #4 x 1 pc  
5-Star Base
-  #5 x 1 pc  
Seat Plate w/Handle
-  #6 x 1 pc  
Cylinder Cover
-  #7 x 1 pc  
Gas Lift Cylinder

### Parts List (Continued)

-  #8 x 5 pcs  
Caster

### Hardware List

-  #A x 8 pcs  
Bolt M6x25mm
-  #B x 4 pcs  
Bolt M6x20mm
-  #C x 4 pcs  
Flat Washer
-  #D x 8 pcs  
Cover
-  #E x 1 pc  
Allen Wrench

Note: Right and left are determined by facing the back of the chair in the upright position.



Insert the 5 casters (#8) into the 5-star base (#4). Then insert the gas lift cylinder (#7) into the 5-star base (#4) and the cylinder cover (#6) over the gas lift cylinder (#7).

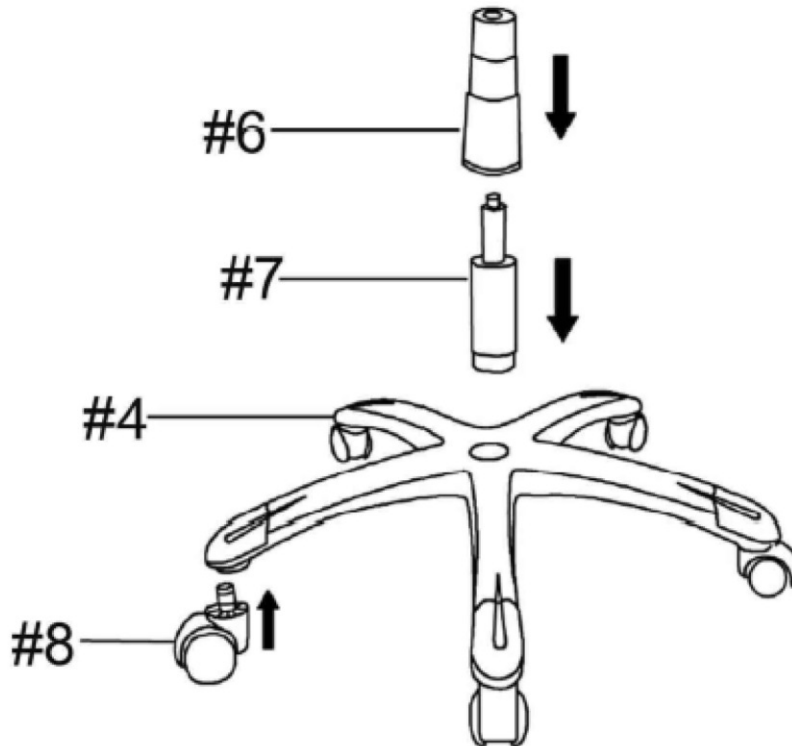

#B x 4 pcs  
#C x 4 pcs

Turn right (clockwise) to tighten

- I. Align the seat plate with handle (#5) with the pre-drilled holes on the bottom of the seat (#2).
- II. Prepare 4 bolt assemblies by inserting the flat washer (#C) onto the bolt (#B).
- III. Insert the bolt assemblies through the seat plate with handle (#5) and secure those bolts using the Allen wrench (#E) to lock them with the seat (#2).

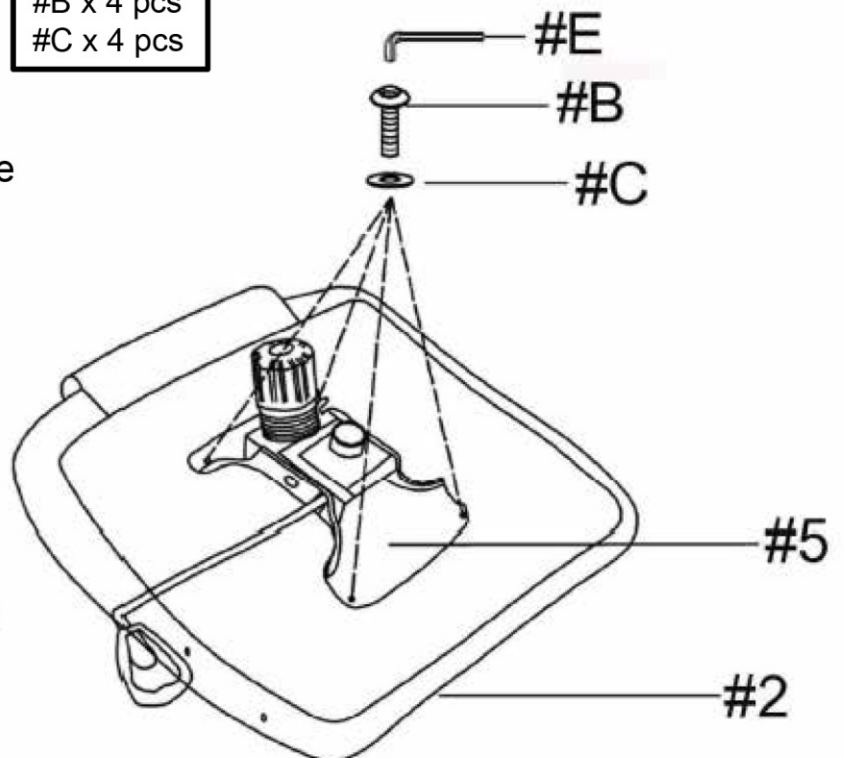



- I. Align the right armrest (#3R) and the left armrest (#3L) with the pre-drilled holes on the sides of the seat (#2).
- II. Insert 4 bolts (#A) through the pre-drilled holes on the armrests and secure those bolts using the Allen wrench (#E) to lock them with the seat (#2). Place the 4 covers (#D) over the bolts (#A).

#A x 4 pcs  
#D x 4 pcs

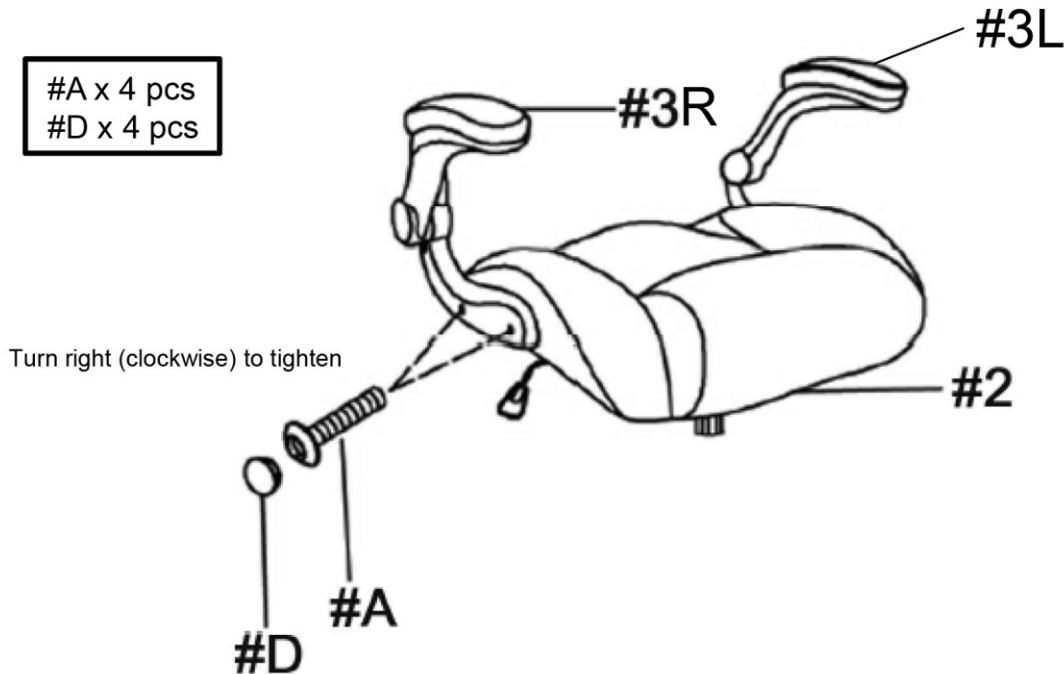

- I. Align the backrest (#1) with the pre-drilled holes of the right armrest (#3R) and the left armrest (#3L).
- II. Insert 4 bolts (#A) through the pre-drilled holes on the armrests and secure those bolts using the Allen wrench (#E) to lock them with the backrest (#1). Place the 4 covers (#D) over the bolts (#A).

#A x 4 pcs  
#D x 4 pcs

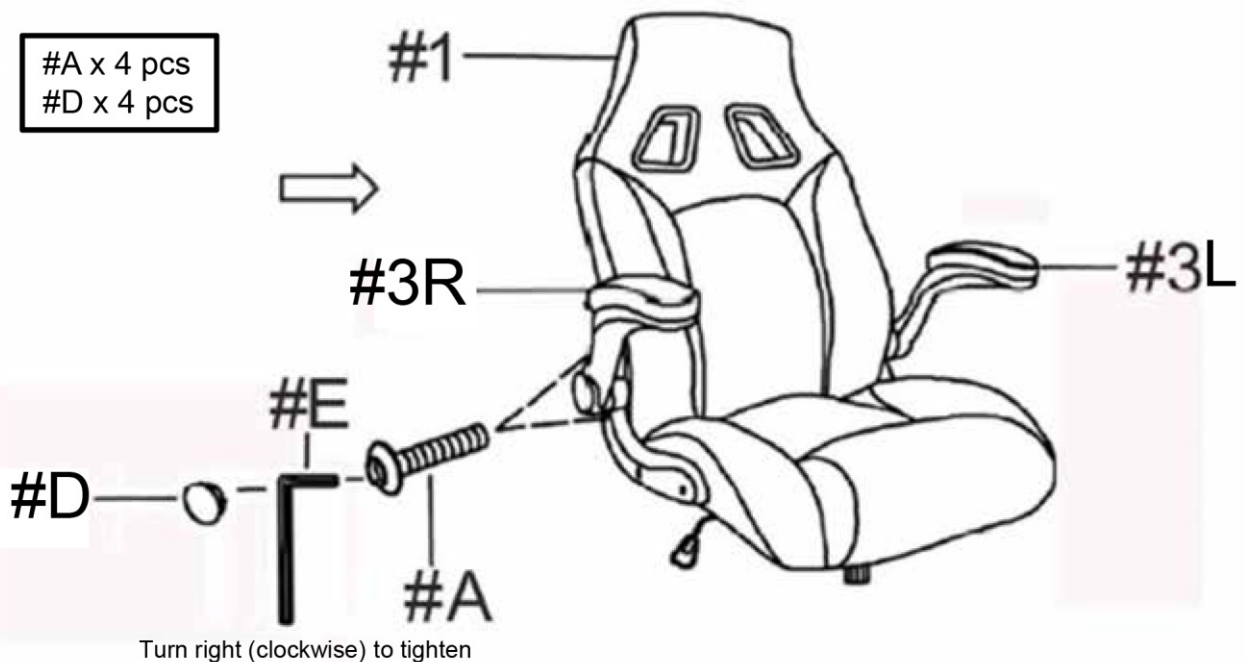



Place the assembled seat plate with handle (#5) onto the assembled gas lift cylinder (#7). Make sure the parts are firmly secured. With the chair rested on a flat surface, check that all parts are secured, the chair is stable and the up/down lift is working properly.



ASSEMBLY IS COMPLETED