

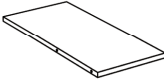











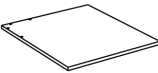

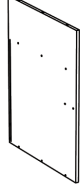
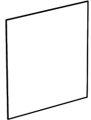
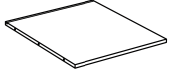
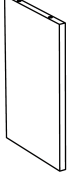
PARTS LIST

				
1x3 520x240mm	2x2 742x240mm	3x1 742x240mm	4x1 888x118mm	5x1 550x480mm
				
6x1 550x526mm	7x1 550x742mm	8x1 519x473mm	9x1 550x464mm	10x1 343x240mm
				
11x1 920x550mm	12x2 $\phi 30$	13x1 920x160mm	14x1 479x240mm	
				
15x1 400x118mm	16x1 400x118mm	17x1 410x118mm	18x1 419x393mm	
				
19x1 457x160mm	20x1 458x341mm	21x1 463x80mm	22x1 344x160mm	

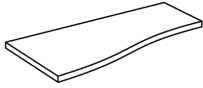
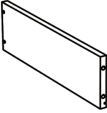
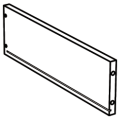
ACCESSORIES LIST

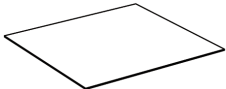
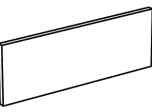
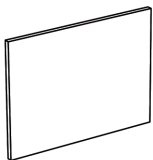

Ax24 M6x40mm



Bx24 Φ 15x11mm



Cx2 12 inch



Dx2 8x40mm



Ex24 M3.5x14mm

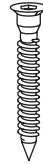

Fx37 M5x40mm



#3 x 1



Gx10 Φ 5x12mm

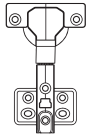

Hx2



11x4

Ix6 M4x18mm

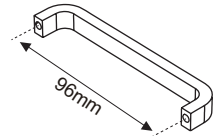

12x2

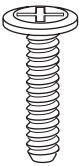

Kx2 M8x25mm

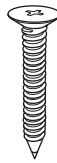

Lx4 M3.5x25mm

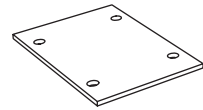

Mx1 37x37mm

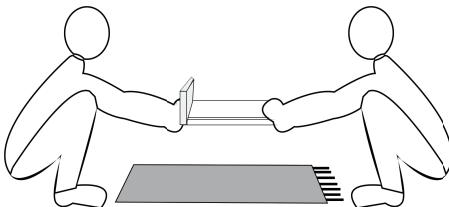

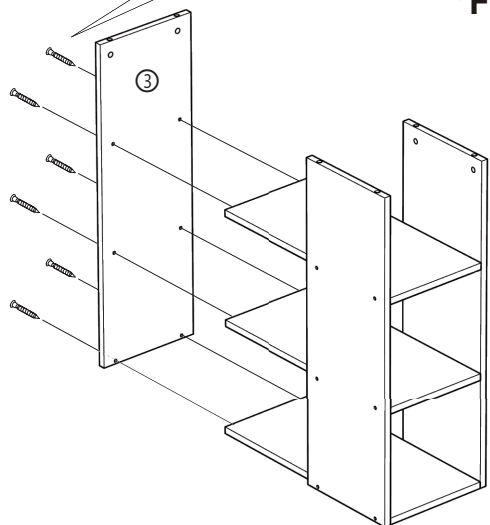
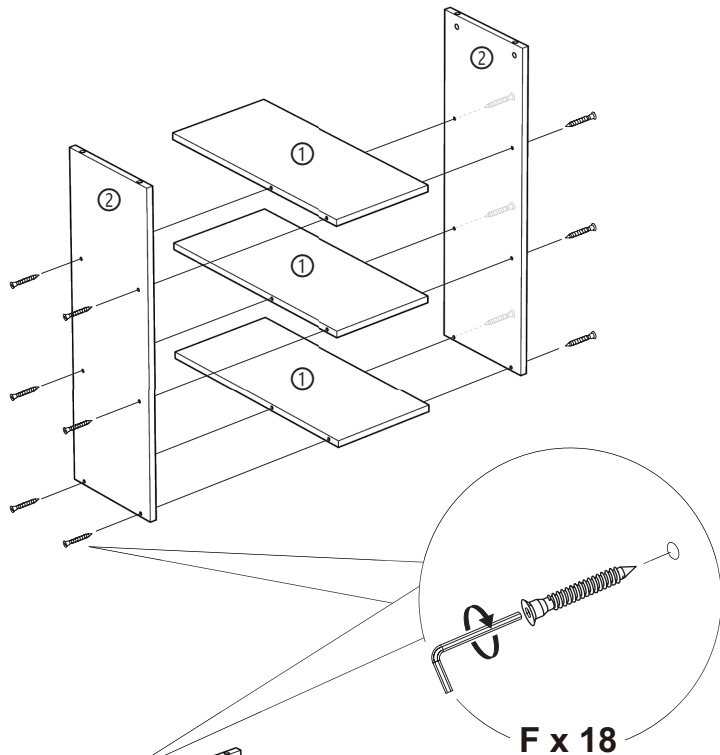

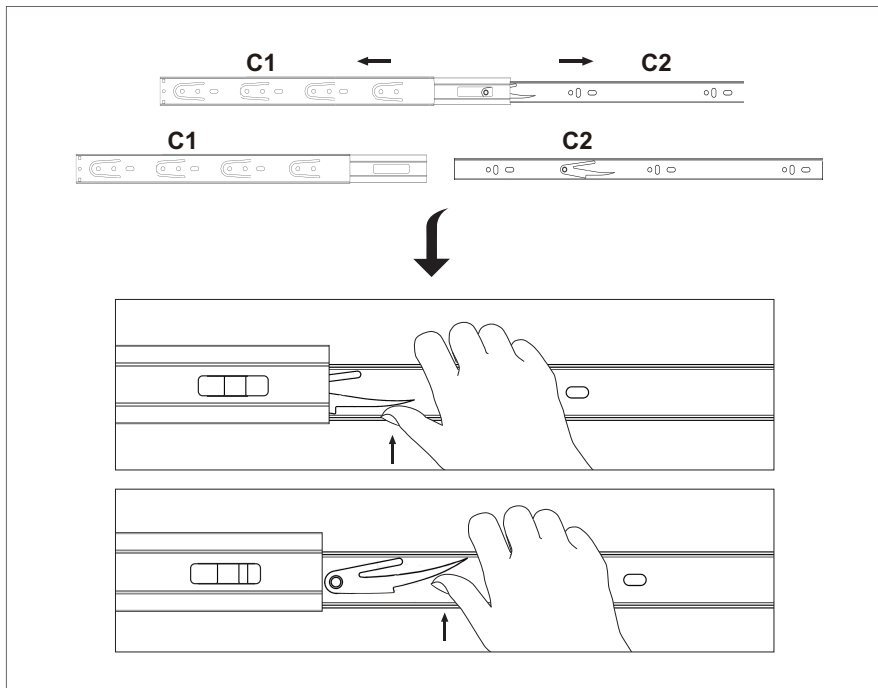
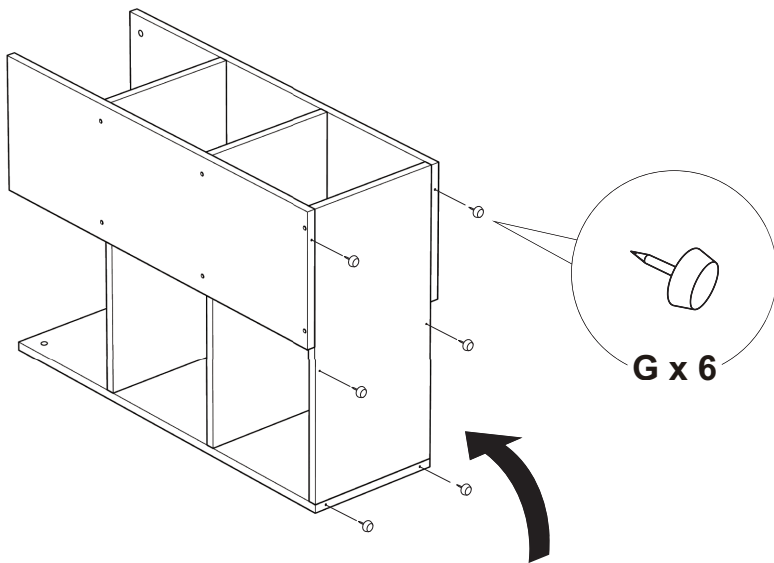

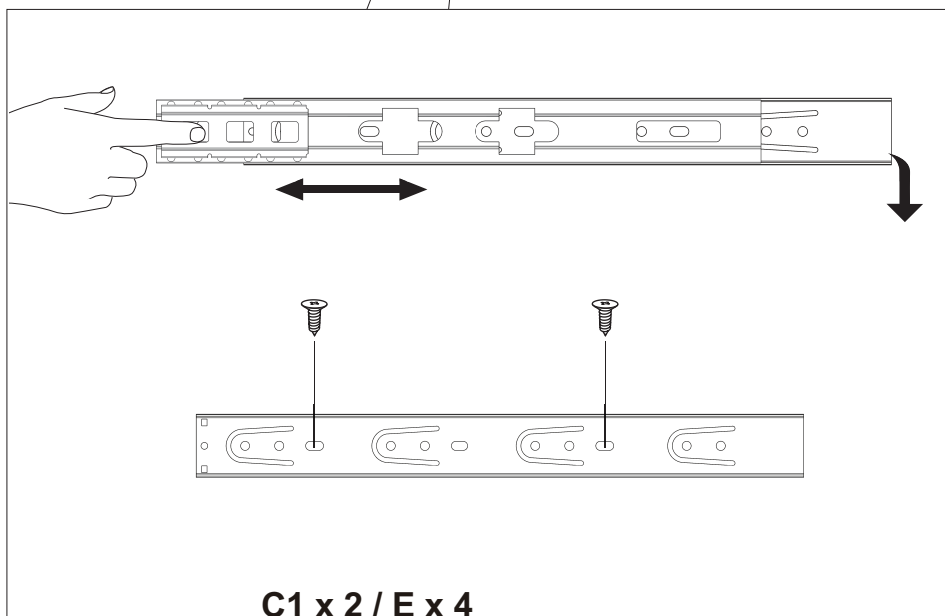
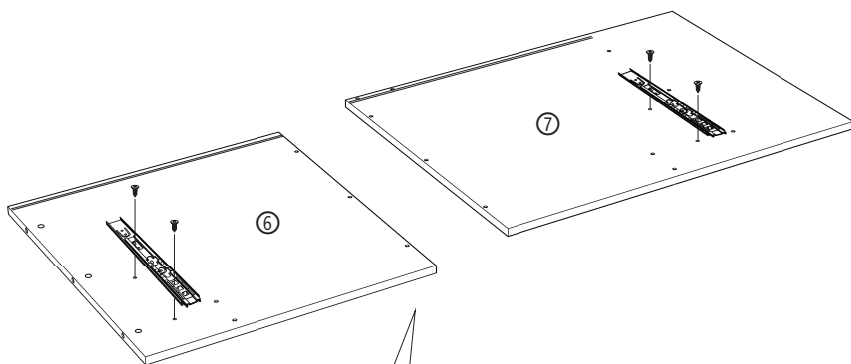

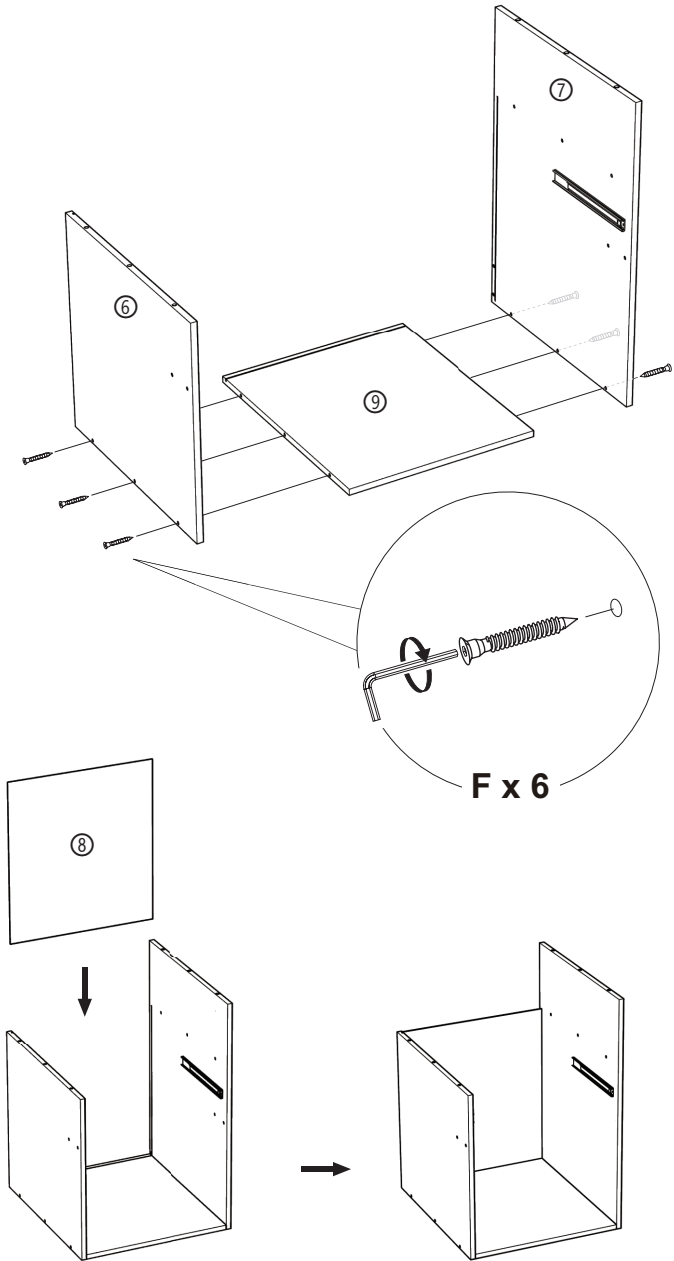

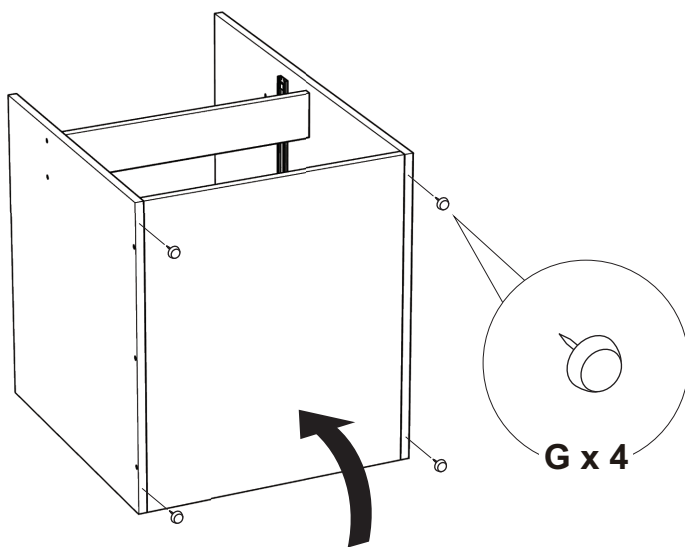
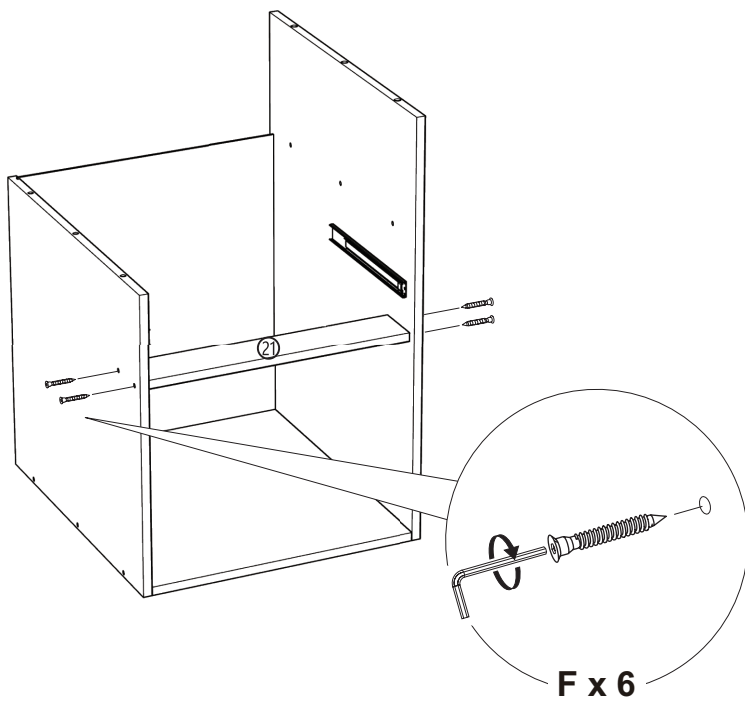

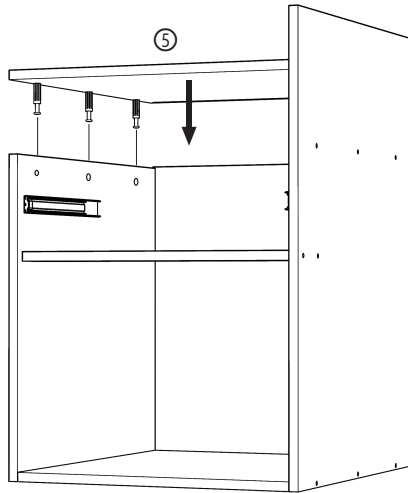
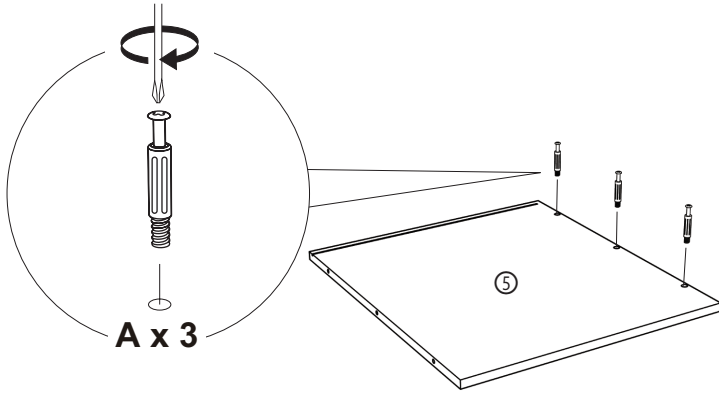

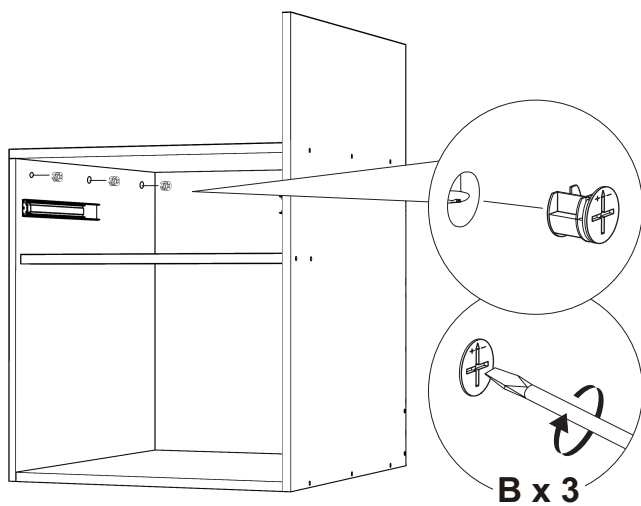
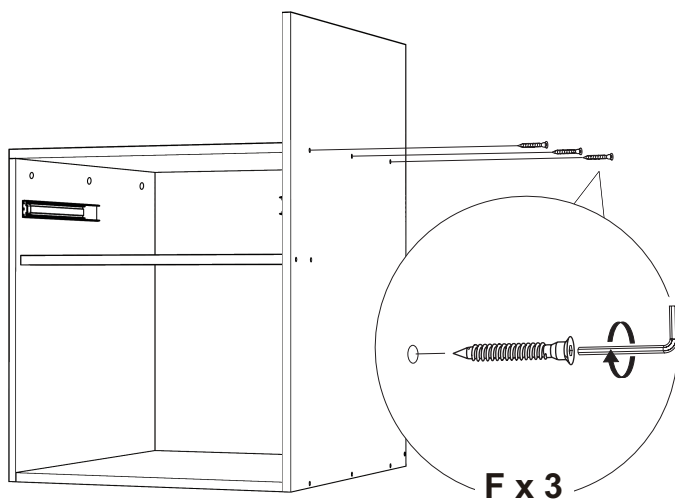

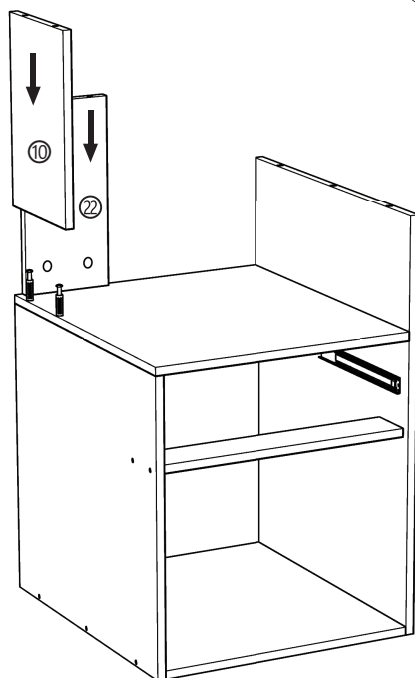
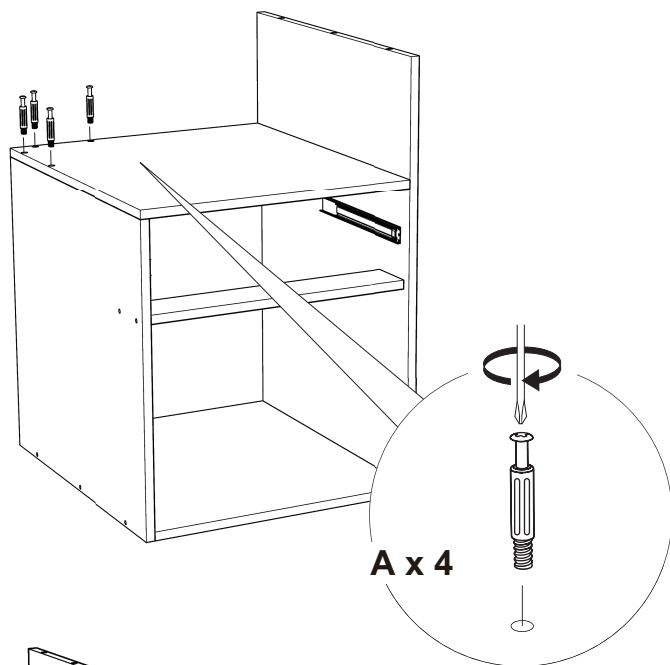

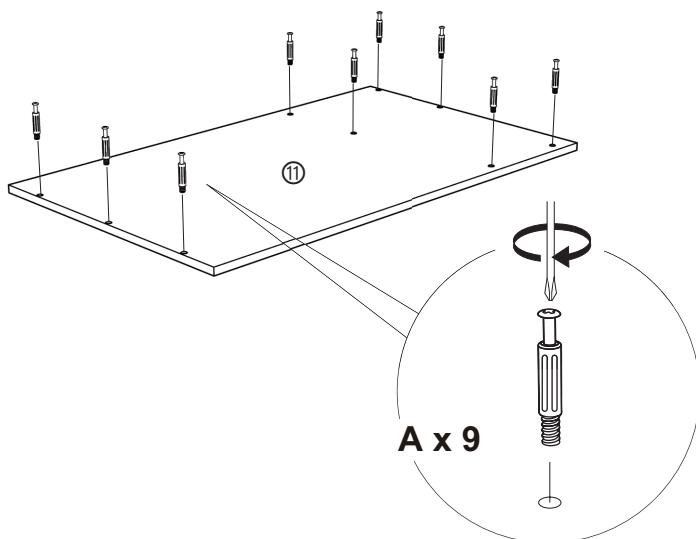
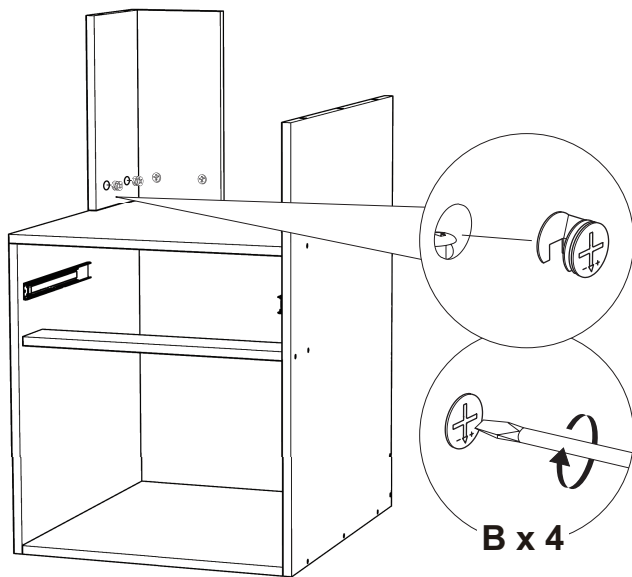

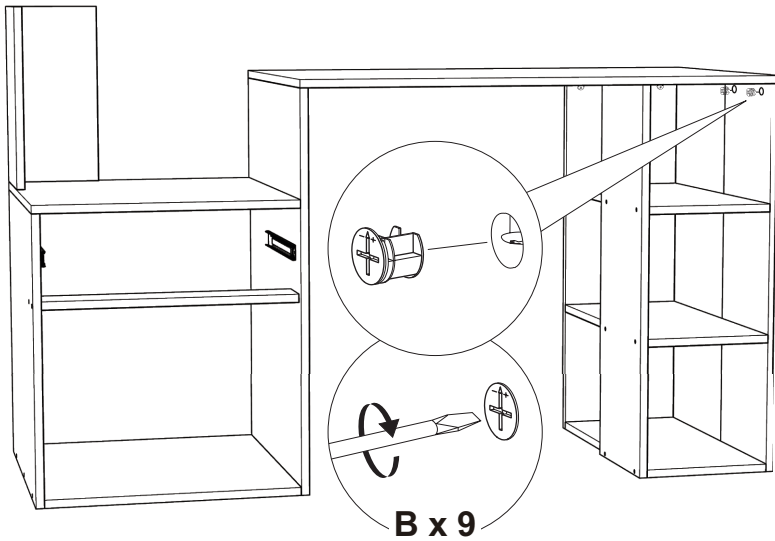
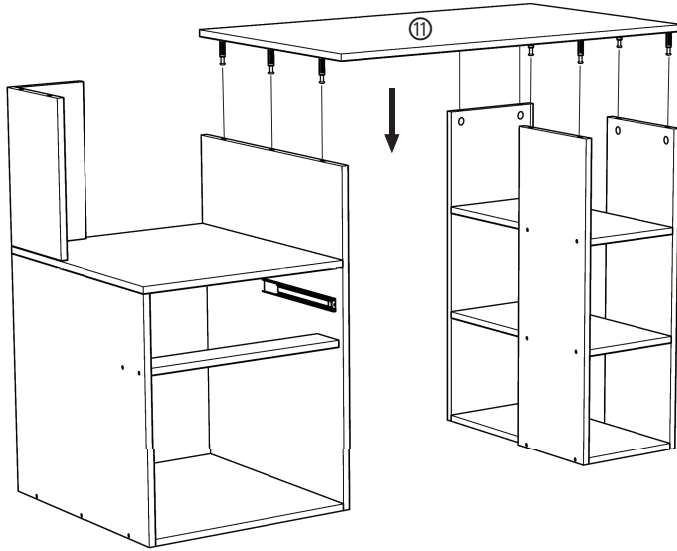

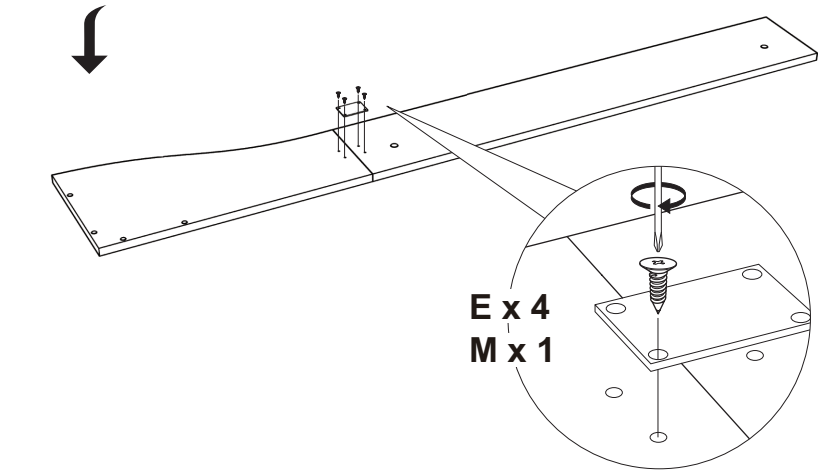
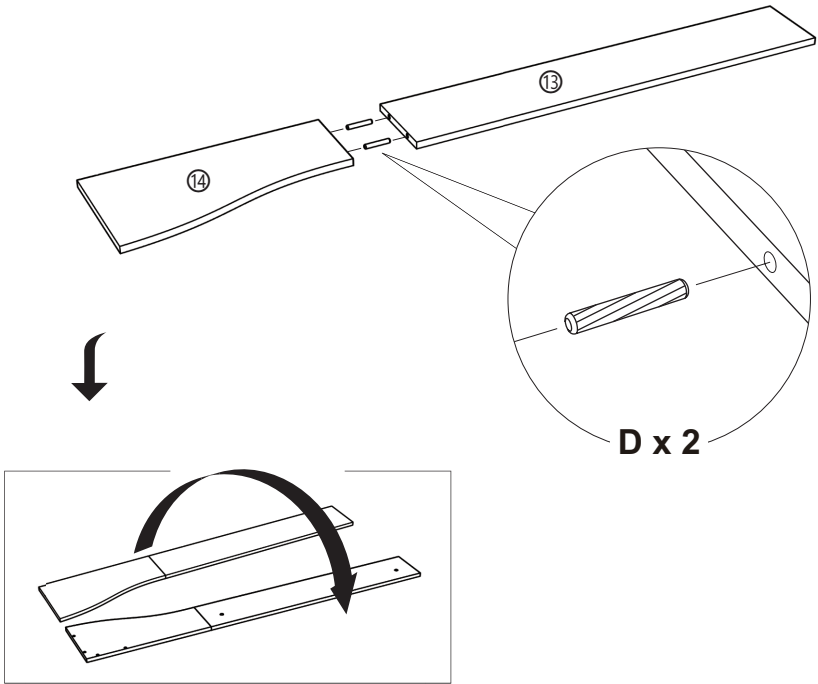

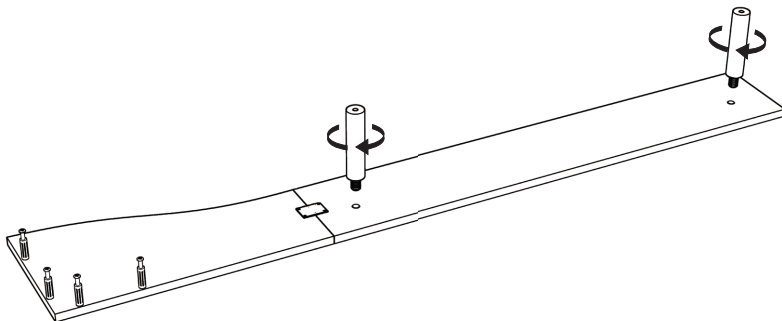
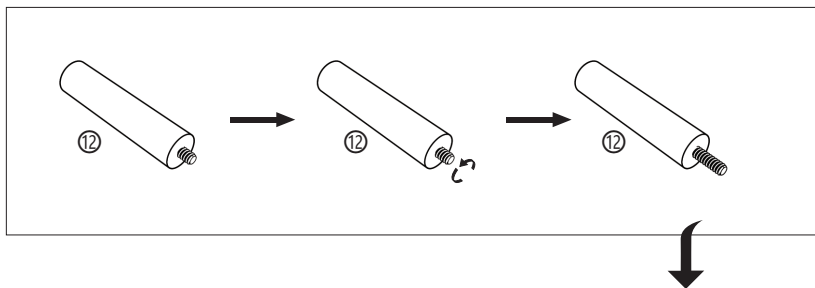
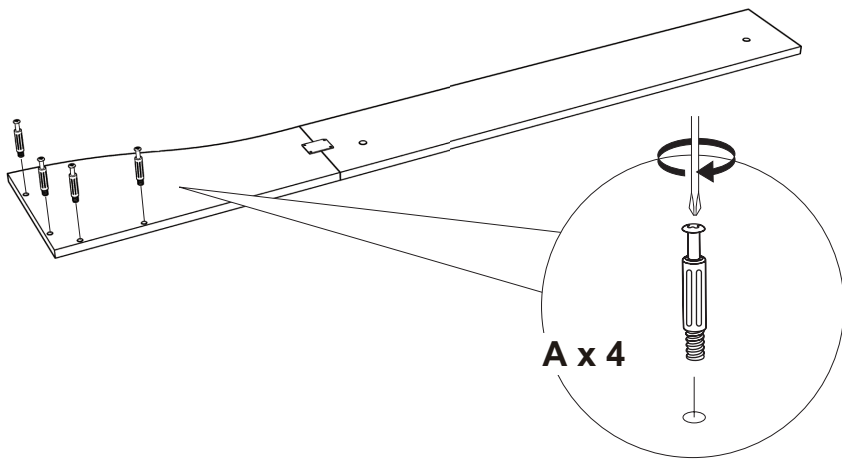

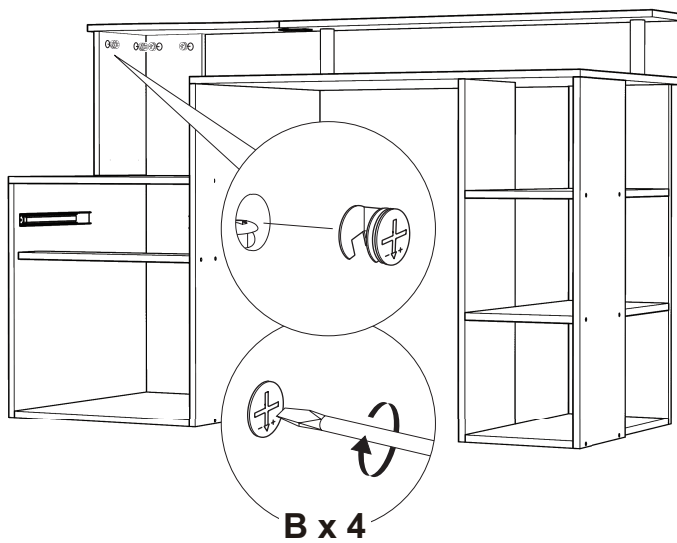
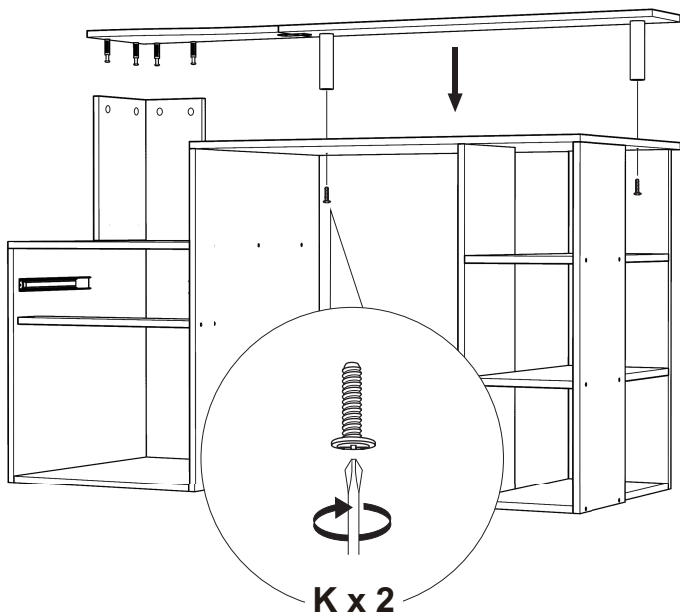

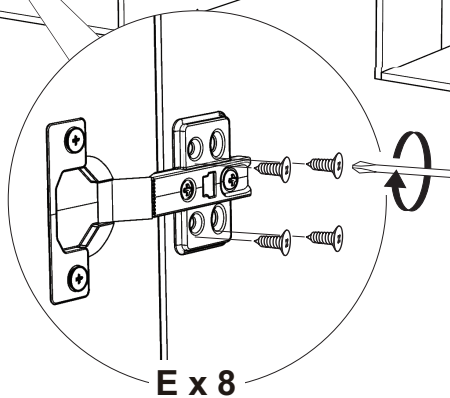
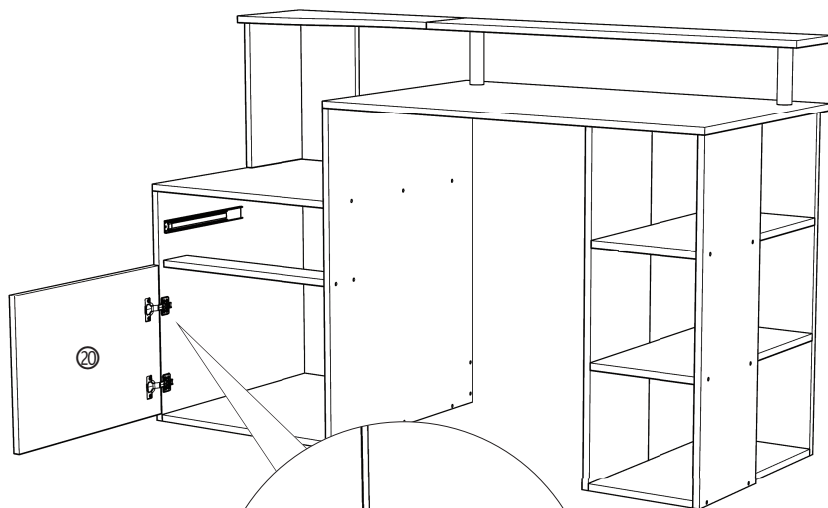
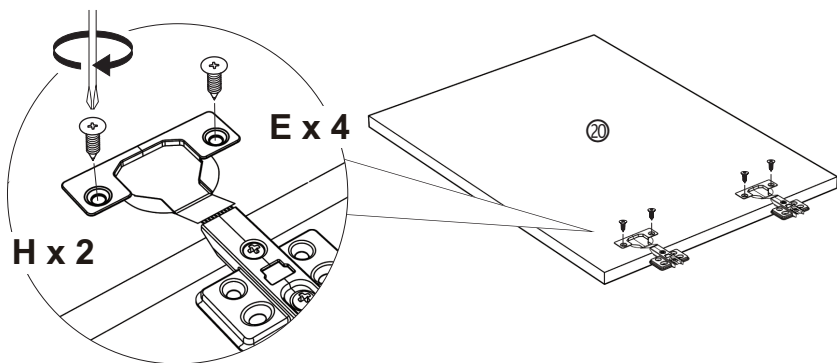

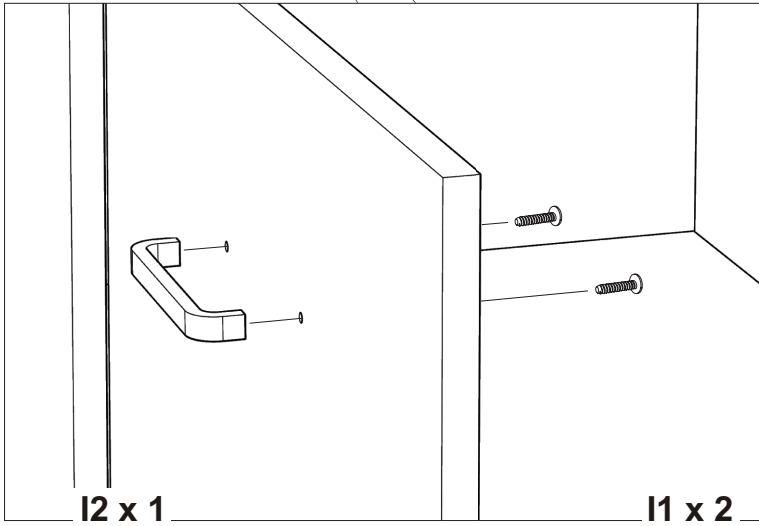
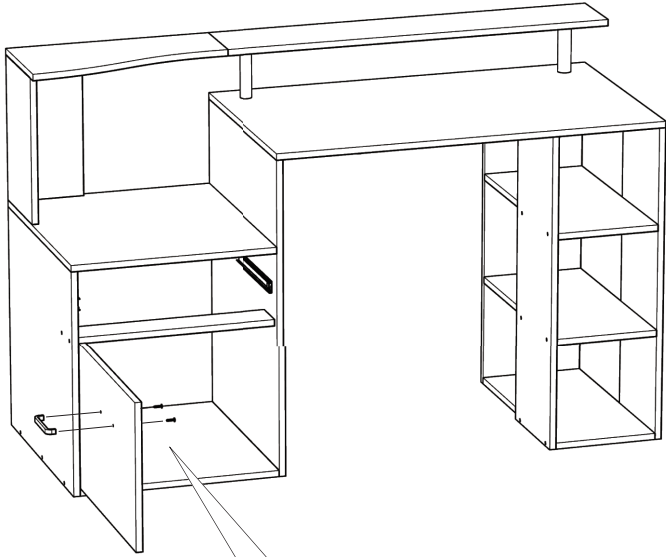

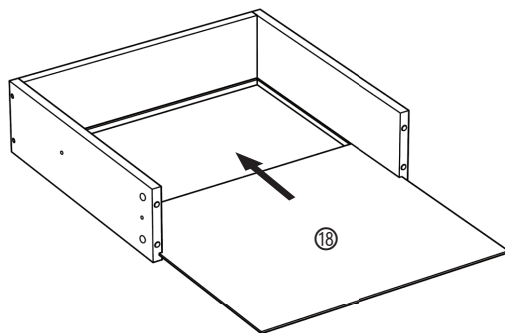
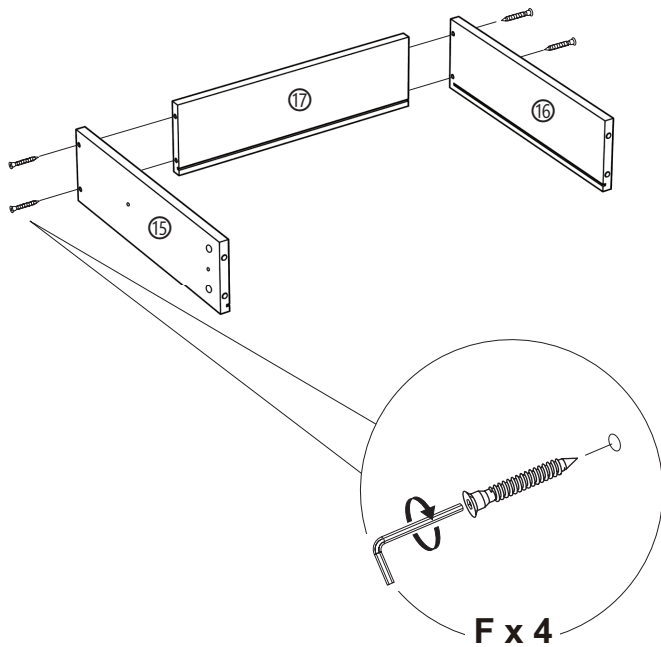

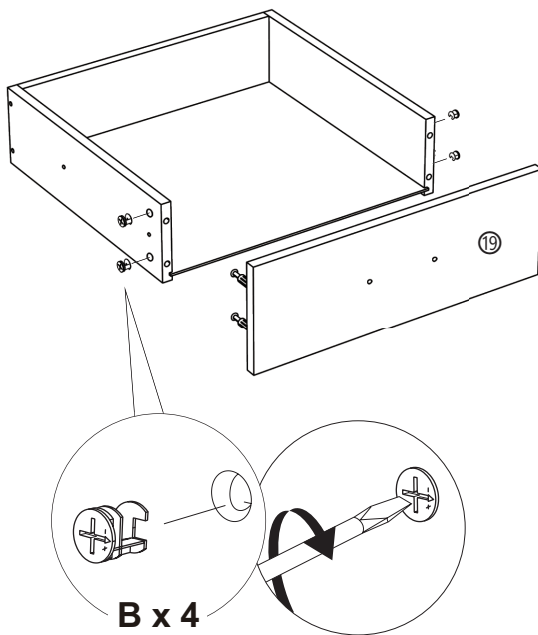
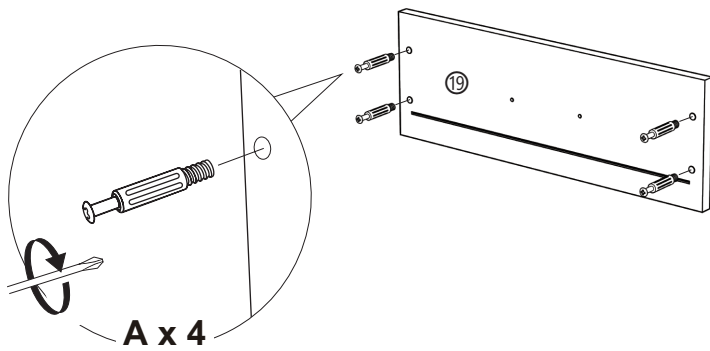

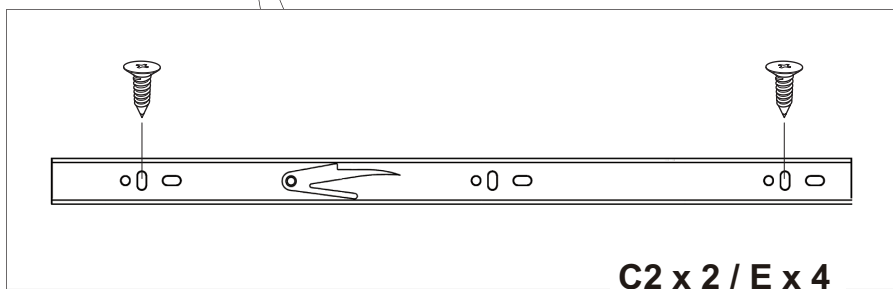
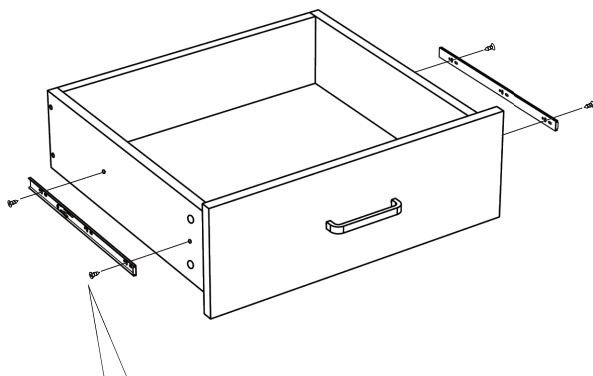
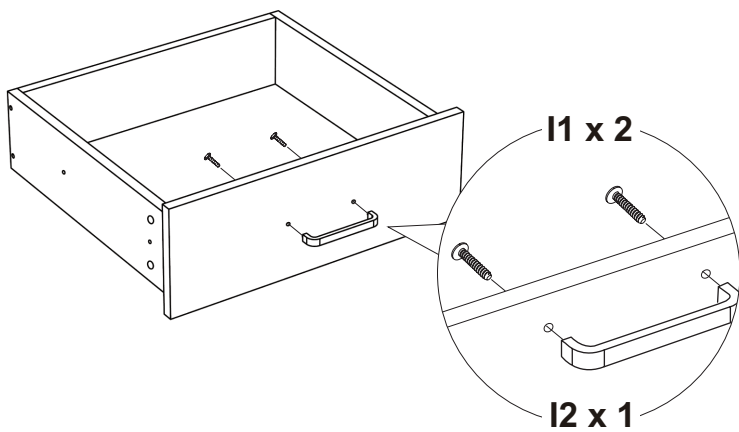

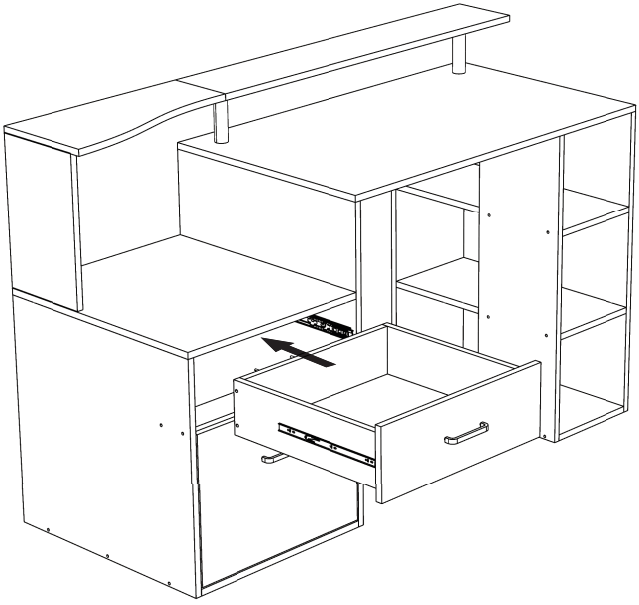

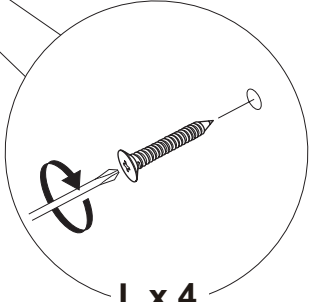
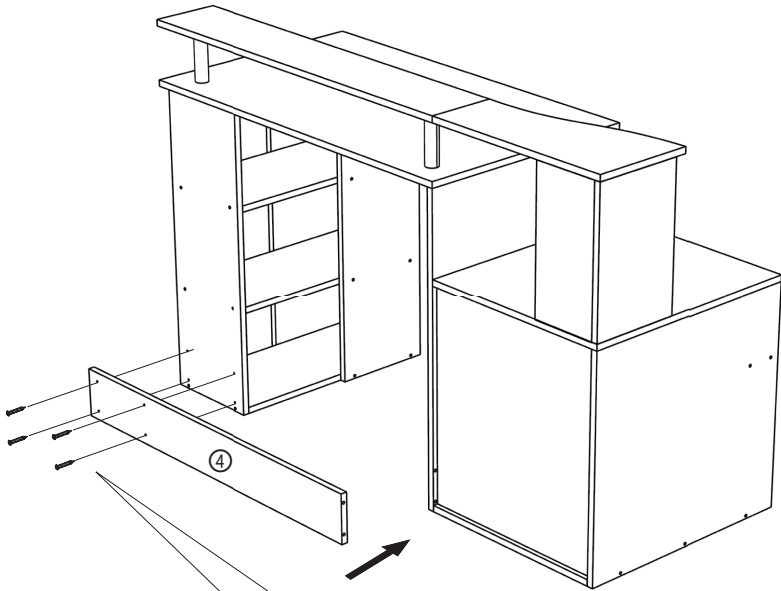

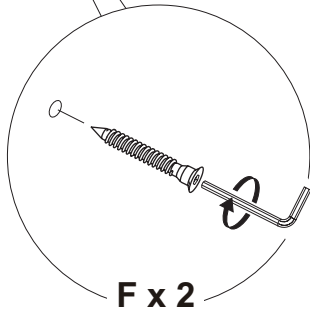
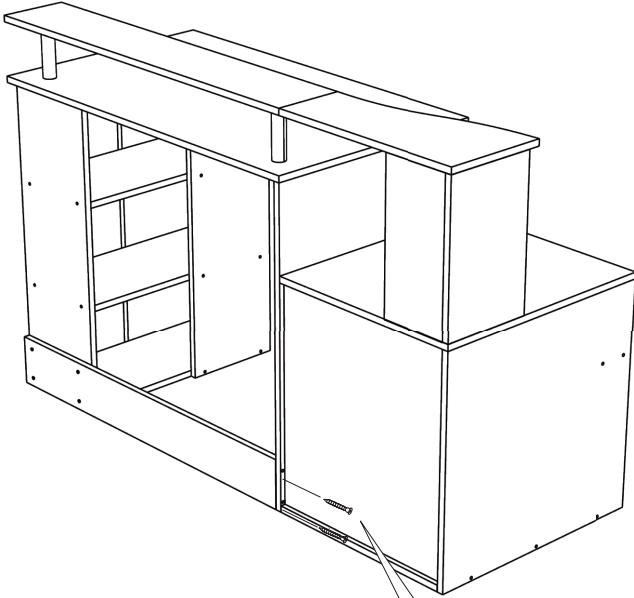

NOTICE

EN

1. Please do not exceed the weight limits of this item.
2. Firmly secure all bolts, screws and knobs before use.
3. Reconfirm that all bolts, screws and knobs are secure after every 90 days.
4. Fasten screws loosely during initial assembly. Do not tighten the screws firmly until the item is assembled completely.
5. Do not use or store this item in the proximity of an open flame or flammable chemicals.

FR

1. Veuillez ne pas dépasser le poids recommandé.
2. Veuillez vous assurer que toutes les vis et écrous sont bien serrés avant la première utilisation.
3. Veuillez resserrer régulièrement toutes les vis et écrous pour prolonger la durée de vie du produit.
4. Lors de la première installation, veuillez ne pas serrer complètement les vis et les écrous. Après avoir terminé toutes les étapes d'installation, veuillez serrer toutes les vis et écrous uniformément.
5. N'utilisez pas le produit à proximité de flammes nues ou de matériaux inflammables.

DE

1. Bitte überschreiten Sie nicht das empfohlene Gewicht.
2. Bitte stellen Sie vor dem ersten Gebrauch sicher, dass alle Schrauben und Muttern fest angezogen sind.
3. Ziehen Sie alle Schrauben und Muttern regelmäßig wieder an, um die Lebensdauer des Produkts zu verlängern.
4. Bitte ziehen Sie die Schrauben und Muttern während der Erstinstallation nicht vollständig an. Ziehen Sie nach Abschluss aller Installationsschritte alle Schrauben und Muttern gleichmäßig an.
5. Verwenden Sie das Produkt nicht in der Nähe von offenen Flammen oder brennbaren Materialien.

NOTICE

ES

1. No utilice más del peso recomendado.
2. Asegúrese de que todos los tornillos y tuercas estén completamente apretados antes del uso inicial.
3. Vuelva a apretar todos los tornillos y tuercas regularmente para prolongar la vida útil del producto.
4. No apriete completamente los tornillos y tuercas durante la instalación inicial, y apriete todos los tornillos y tuercas uniformemente después de que se completen todos los pasos de instalación.
5. No utilice el producto cerca de llamas abiertas o materiales inflamables.

IT

1. Si prega di non superare il peso consigliato.
2. Assicurarsi che viti e dadi (tutti) siano completamente serrati prima dell'utilizzo.
3. Verificare regolarmente (ogni 90 giorni) che viti e dadi siano ben serrati.
4. Si prega di non serrare completamente viti e dadi durante l'installazione iniziale. Solamente dopo aver completato tutti i passaggi di installazione, serrare viti e dadi in modo uniforme.
5. Non utilizzare il prodotto vicino a fiamme libere o materiali infiammabili.