

INSTRUCTION MANUAL

ASSEMBLY INSTRUCTIONS



Carefully unpack all the components and verify that all the necessary parts are included as listed in the packaging.

Identify each component and refer to the provided assembly diagram or step-by-step instructions. Assemble the furniture in the order specified to ensure proper alignment and fit.

Use the provided tools or recommended tools for assembly. Do not use excessive force when tightening screws or bolts.

If any difficulties arise during assembly, consult the troubleshooting section or contact our customer support.

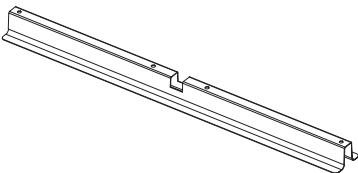
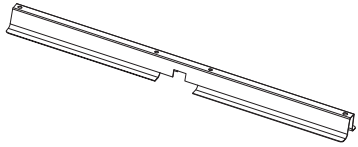
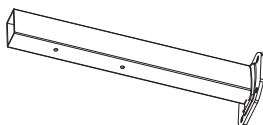
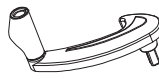
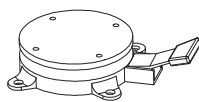
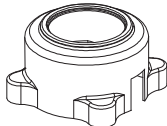
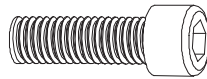
PART

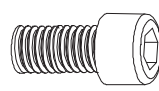
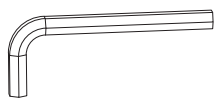
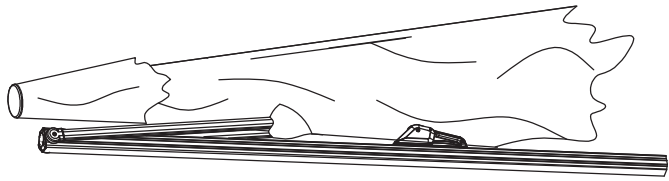
NO.	PICTURE	QTY	NO.	PICTURE	QTY
A		1	B		1
C		1	D		1
E		1	F		1
G	 M8x20mm	6	H		10
J	 M8x15mm	4	K		1
L					1

STEP 1

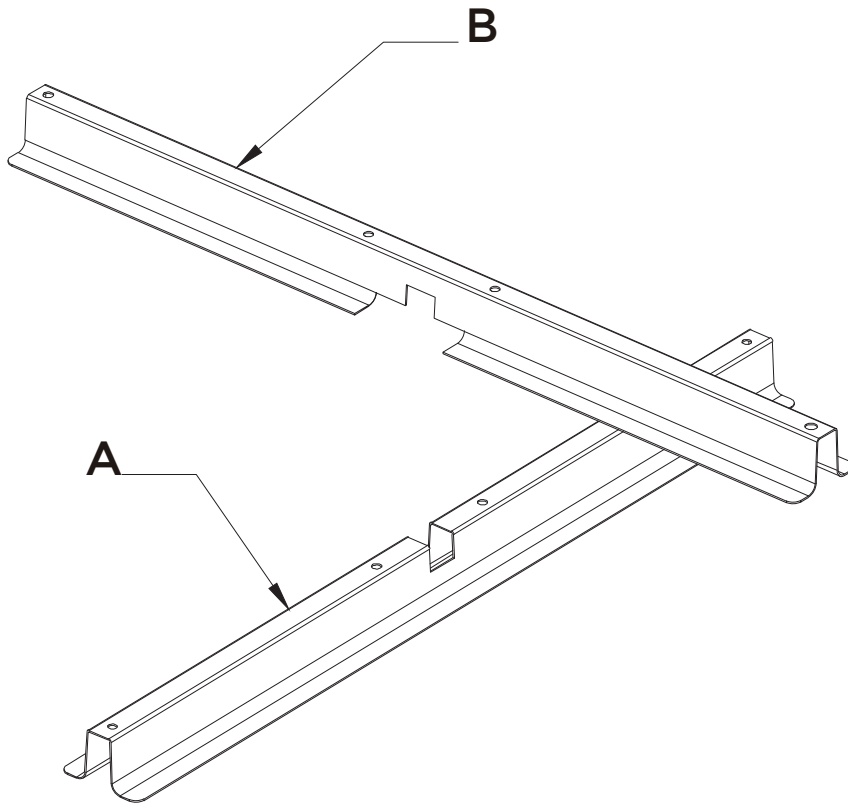

STEP 2

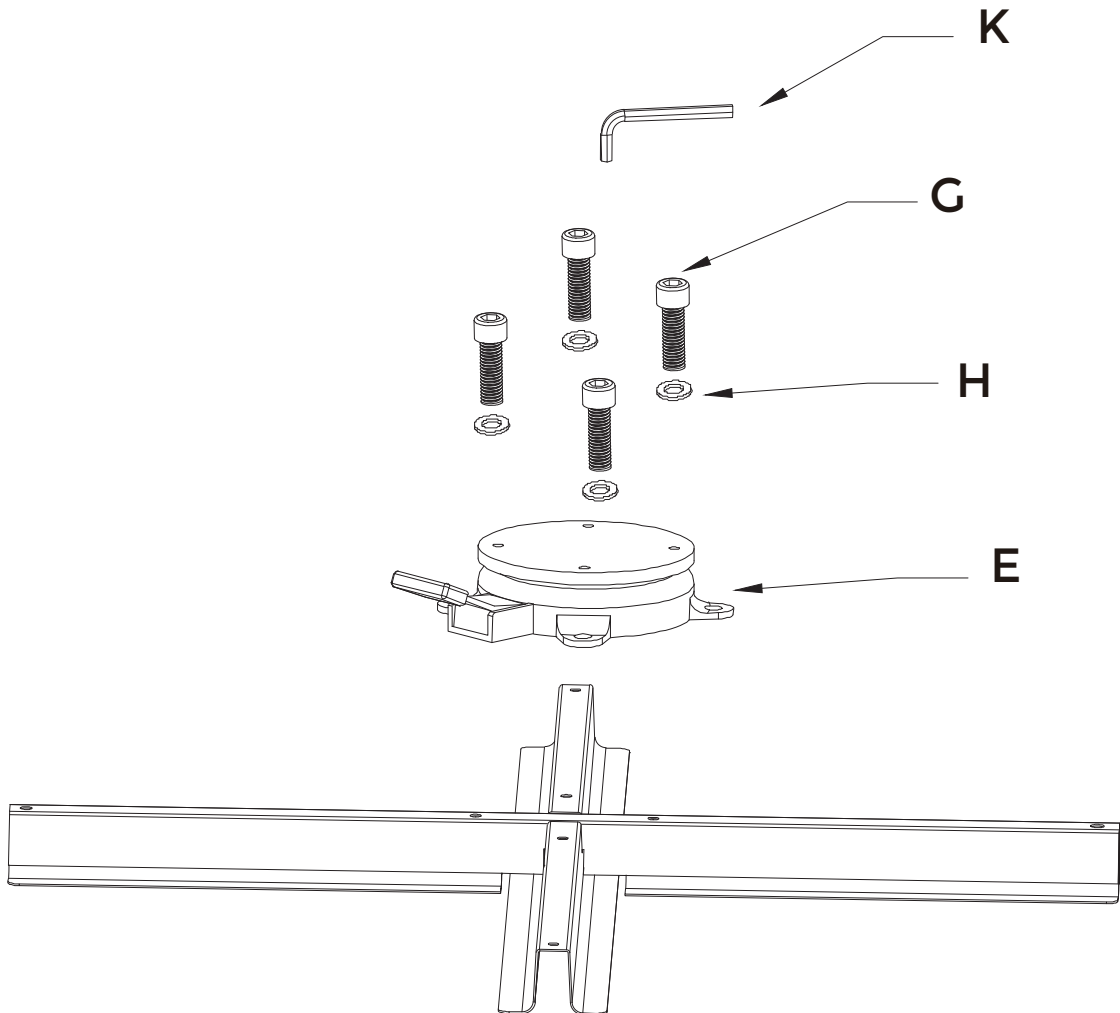

STEP 3

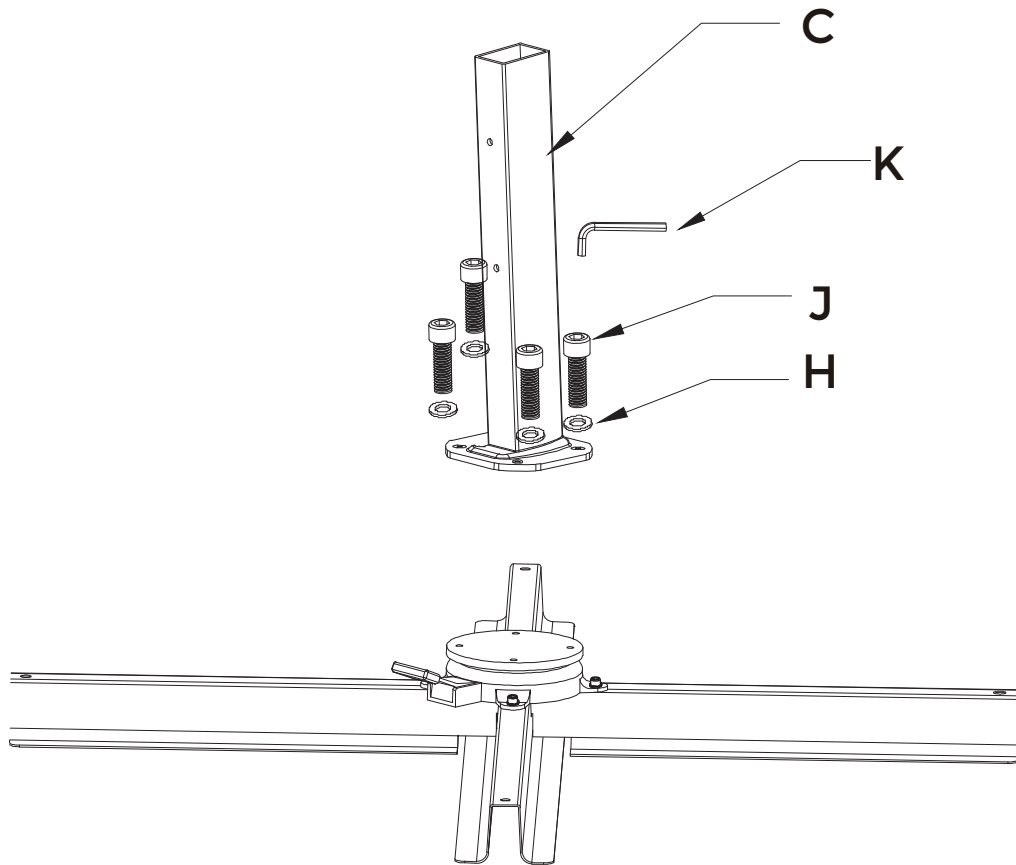

STEP 4

If necessary, pls put umbrella base.

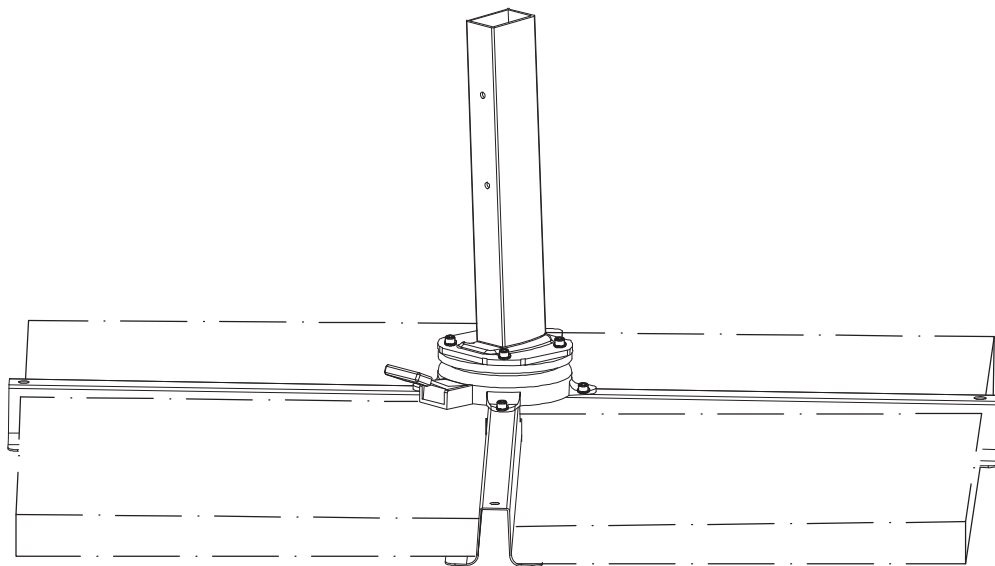

STEP 5

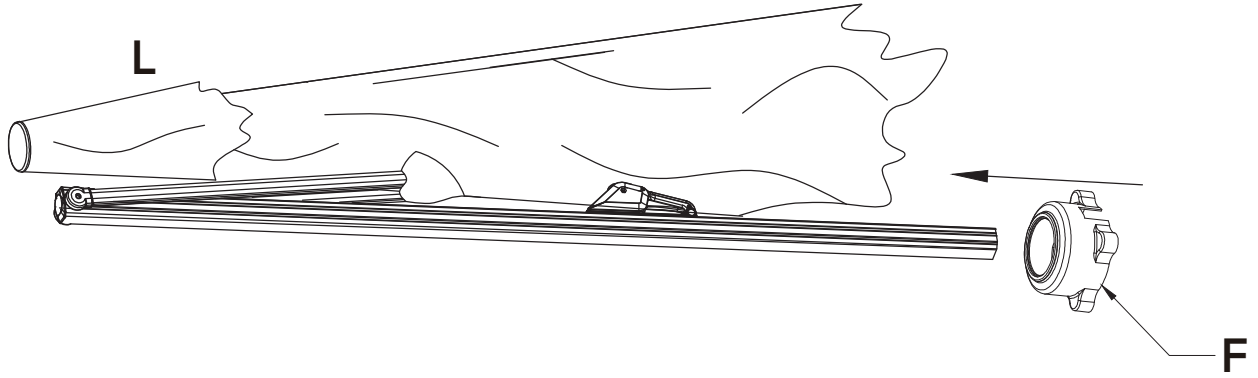

STEP 6

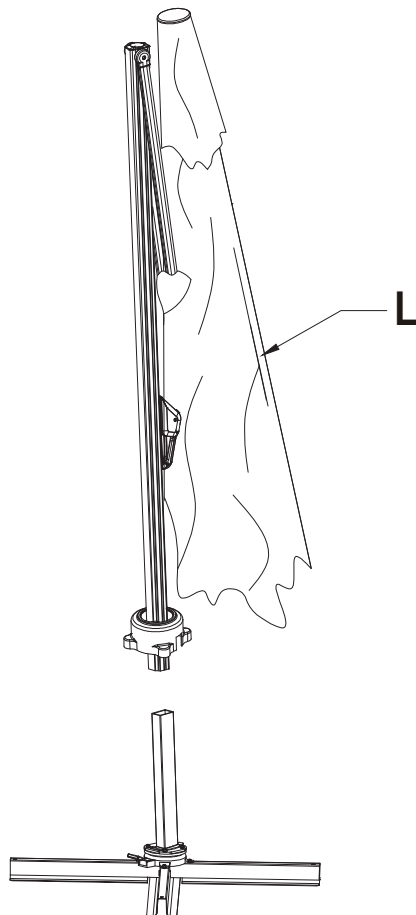

STEP 7

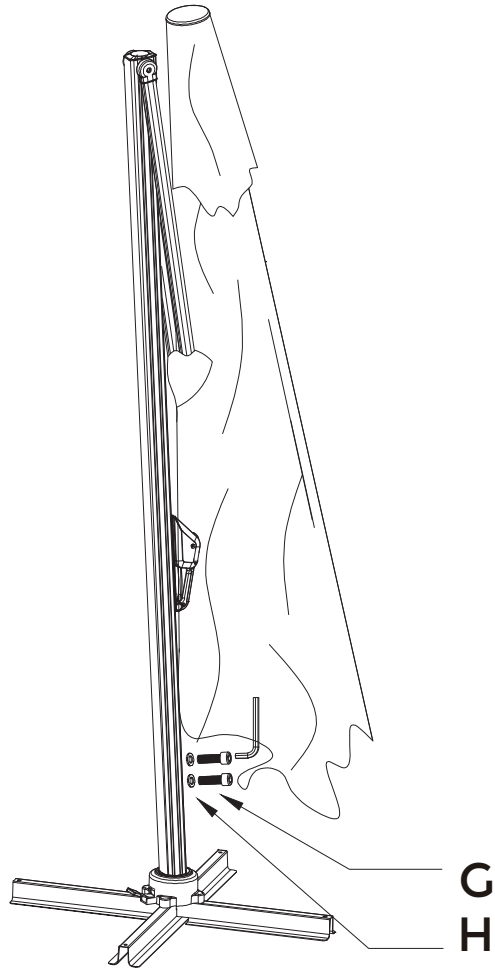

STEP 8

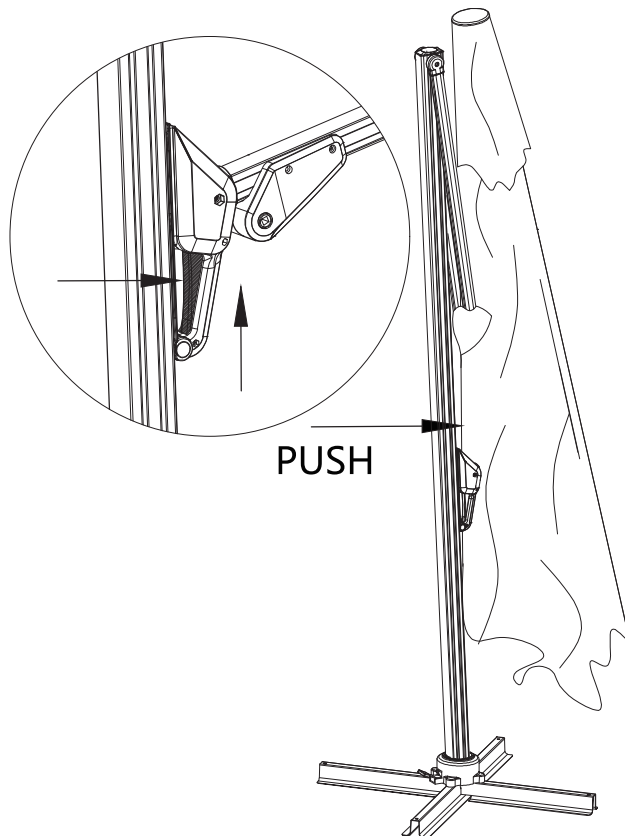

STEP 9

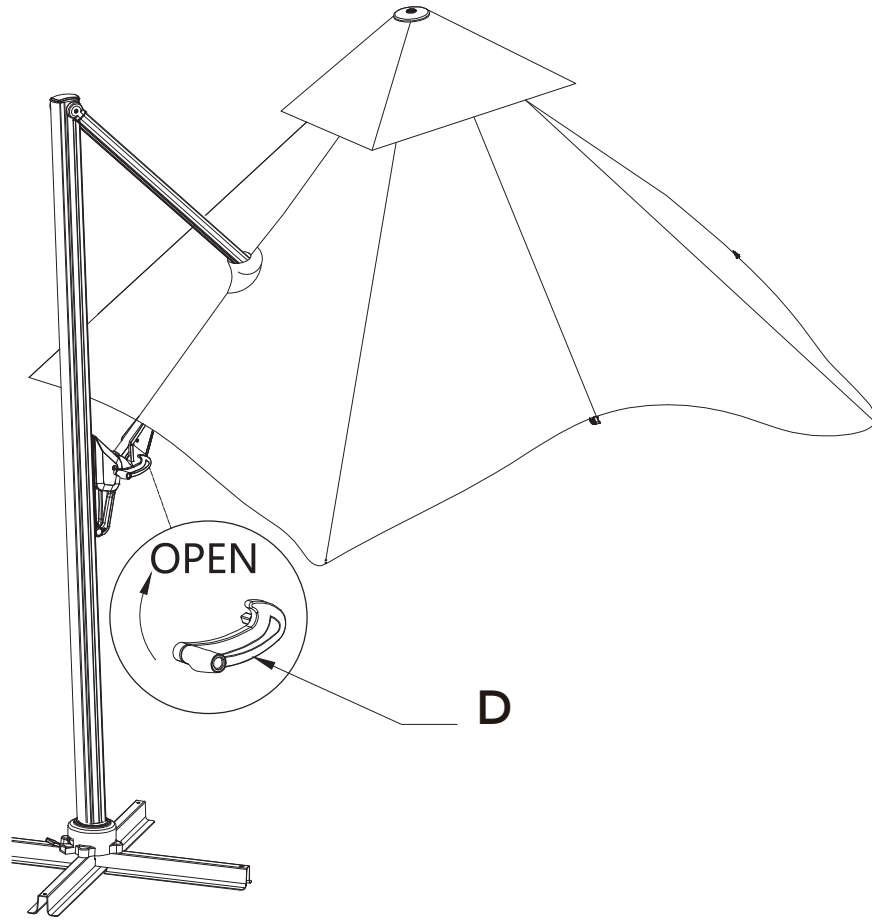

STEP 10

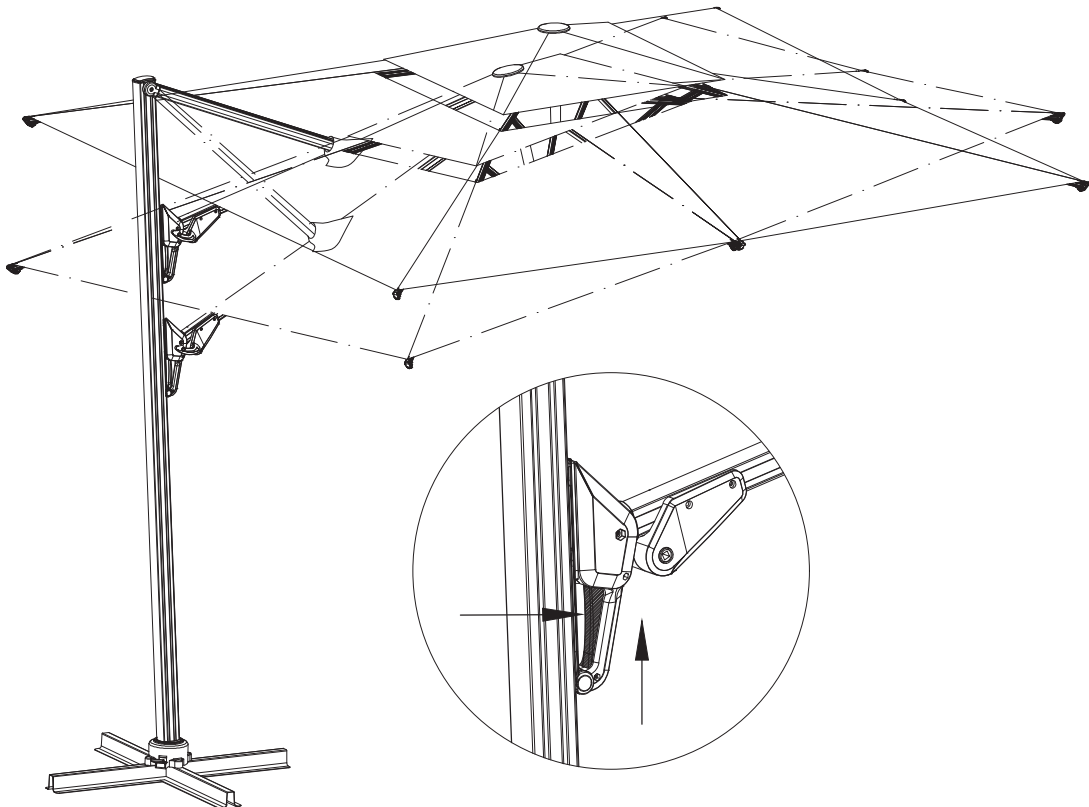

STEP 11

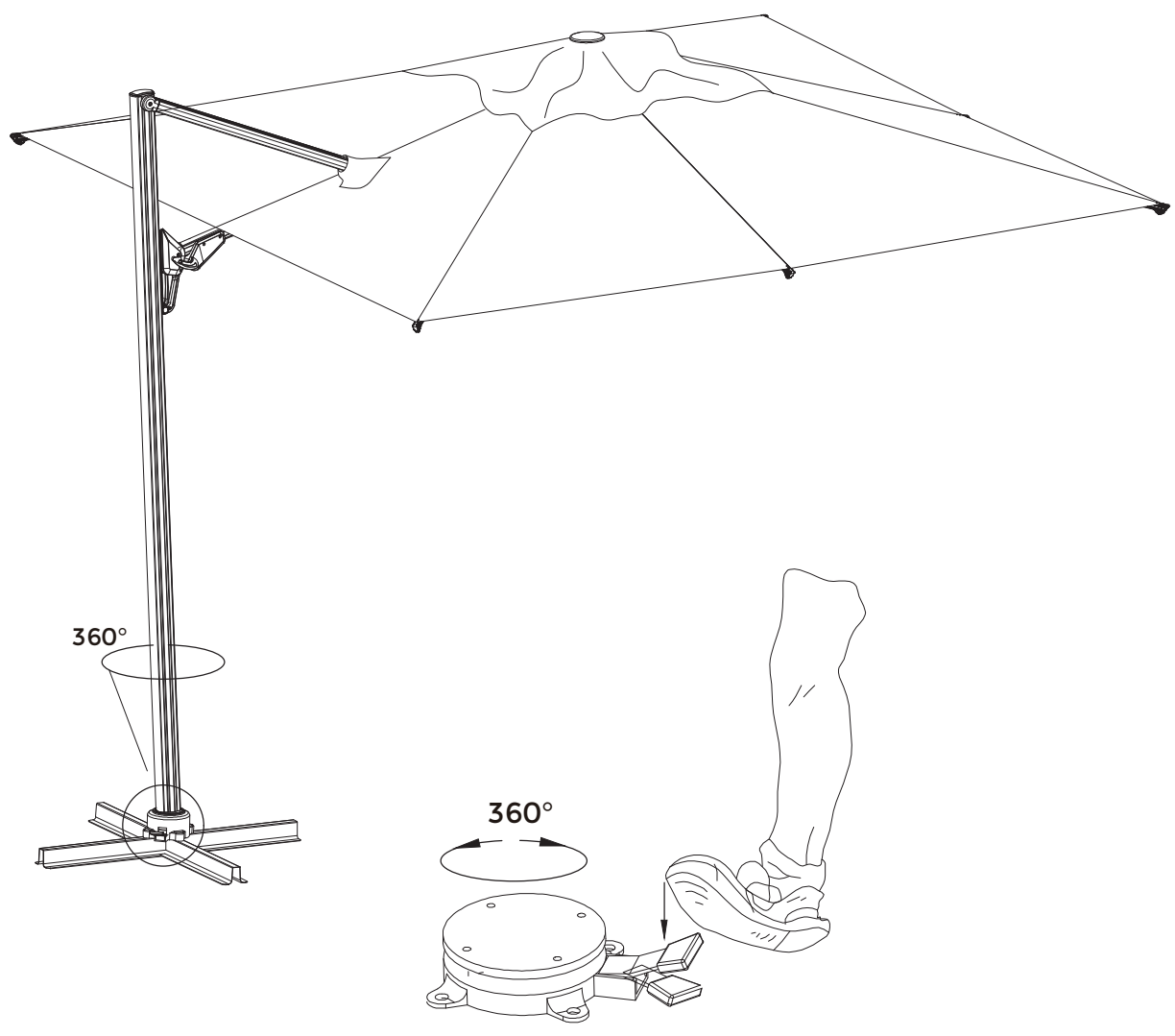

STEP 12 If necessary, pls install the wind rope.

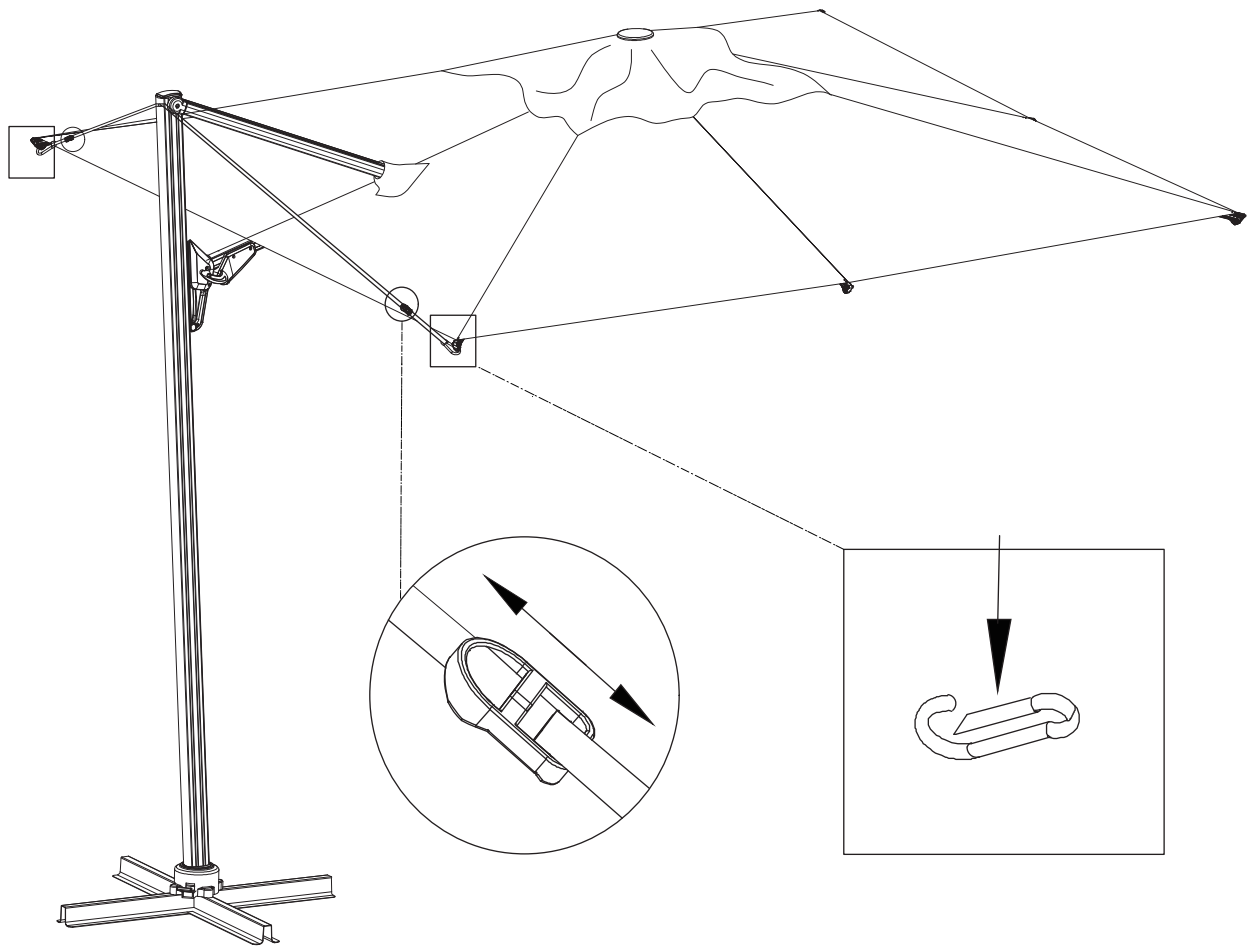



MAINTENANCE AND CARE

Regularly inspect your product for signs of wear, loose strands, or damage. Address any issues promptly.

Hardware may loosen over time. Periodically check to make sure all connections are tight. Re-tighten if necessary.

Do not dispose of any packaging or contents of the shipping carton until assembly is completed to avoid accidentally discarding small parts or hardware.

Do not use sharp objects that may scratch the painted surface.

Brush off loose dirt, spray on a cleaning solution of water and mild soap. Use a soft bristle brush to clean. Air dry.

Keep umbrella closed if there are windy conditions or when not in use.

We recommend a base for safe and stable in outdoor use.



WARRANTY INFORMATION

Warranty Coverage: Our warranty provides protection against manufacturing defects in materials and workmanship for a specified period from the date of purchase, as outlined in the accompanying warranty documentation.

Exclusions: The warranty does not cover damages resulting from misuse, negligence, accidents, normal wear and tear, unauthorized repairs or modifications, improper assembly, or failure to adhere to the care and maintenance guidelines provided.