

"IMPORTANT, RETAIN FOR FUTURE REFERENCE: READ CAREFULLY"

German: WICHTIG, FÜR SPÄTERE NACHSCHLAGE AUFBEWAHREN: SORGFÄLTIG LESEN

Spanish: IMPORTANTE, GUARDAR PARA REFERENCIA FUTURA: LEER ATENTAMENTE











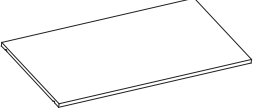
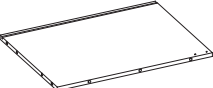
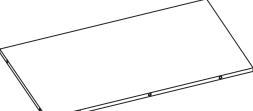

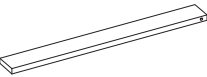
Italian: IMPORTANTE, CONSERVARE PER RIFERIMENTI FUTURI: LEGGERE ATTENTAMENTE

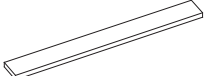
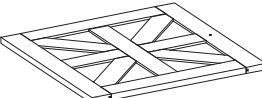
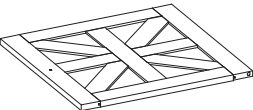
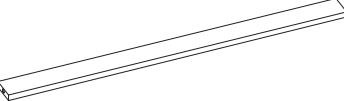
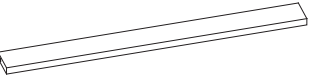
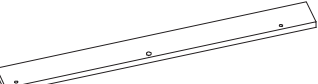
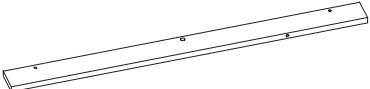
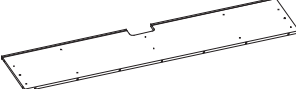

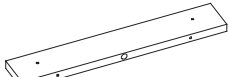
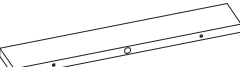

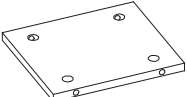





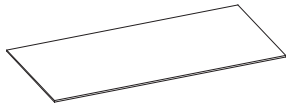
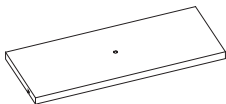
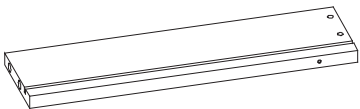
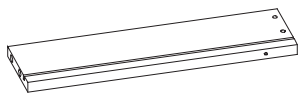
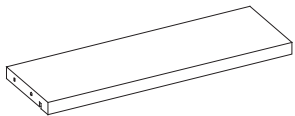
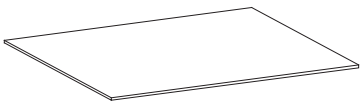
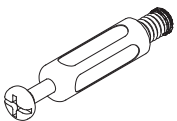

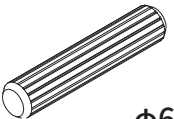
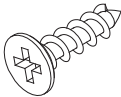

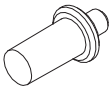



French: IMPORTANT, À CONSERVER POUR RÉFÉRENCE FUTURE : LIRE ATTENTIVEMENT

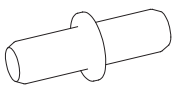

1. Periodically check that all components are tightly secured.
  2. Assemble on a flat, clean, and soft surface.
  3. Confirm all parts are present prior to assembly.
  4. Prepare electric tools in advance for a quicker installation.
1. Prüfen Sie regelmäßig, ob alle Komponenten fest sitzen.
  2. Montieren Sie das Gerät auf einer ebenen, sauberen und weichen Oberfläche.
  3. Vergewissern Sie sich vor dem Zusammenbau, dass alle Teile vorhanden sind.
  4. Bereiten Sie Elektrowerkzeuge im Voraus vor, um eine schnellere Installation zu ermöglichen.
1. Vérifiez périodiquement que tous les composants sont bien fixés.
  2. Assemblez le tout sur une surface plane, propre et douce.
  3. Confirmez que toutes les pièces sont présentes avant l'assemblage.
  4. Préparez les outils électriques à l'avance pour une installation plus rapide.
1. Controllare periodicamente che tutti i componenti siano fissati saldamente.
  2. Assemblare su una superficie piana, pulita e morbida.
  3. Assicurarasi che siano presenti tutte le parti prima dell'assemblaggio.
  4. Preparare gli strumenti elettrici in anticipo per un'installazione più veloce.
1. Revise que todos los componentes estén asegurados con regularidad.
  2. Monte sobre una superficie que sea plana, limpia y suave.
  3. Antes de montar el producto, revise que tenga todas las piezas a mano.
  4. Para facilitar la instalación, prepare las herramientas eléctricas necesarias con tiempo.

Item no. Nr. N° d'article Articolo No. Artículo No.	Reference Image Referenzbild Image de référence Immagine di riferimento Imagen de referencia	Qty. Menge Qté. Qtà Cant.	Item no. Nr. N° d'article Articolo No. Artículo No.	Reference Image Referenzbild Image de référence Immagine di riferimento Imagen de referencia	Qty. Menge Qté. Qtà Cant.
1		X1	2		X1
3		X1	4		X1
5		X1	6		X2

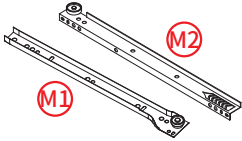
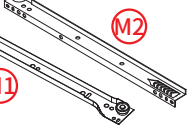
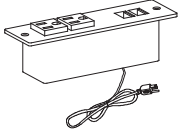
Item no. Nr. N° d'article Articolo No. Artículo No.	Reference Image Referenzbild Image de référence Immagine di riferimento Imagen de referencia	Qty. Menge Qté. Qtà Cant.	Item no. Nr. N° d'article Articolo No. Artículo No.	Reference Image Referenzbild Image de référence Immagine di riferimento Imagen de referencia	Qty. Menge Qté. Qtà Cant.
7		X1	8		X1
9		X1	10		X1
11		X1	12		X1
13		X1	14		X1
15		X1	16		X1
17		X1	18		X1
19		X1	20		X1
21		X1	22		X1
23		X1	24		X1
25		X1	26		X1
27		X1	28		X1

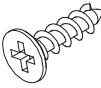
Item no. Nr. N° d'article Articolo No. Artículo No.	Reference Image Referenzbild Image de référence Immagine di riferimento Imagen de referencia	Qty. Menge Qté. Qtà Cant.	Item no. Nr. N° d'article Articolo No. Artículo No.	Reference Image Referenzbild Image de référence Immagine di riferimento Imagen de referencia	Qty. Menge Qté. Qtà Cant.
29		X4	30		X2
31		X2	32		X2
33		X2	34		X2
A		X68	B	 φ12*10mm	X68
C	 φ6*30mm	X27	D	 ST3.5*14mm	X20
E	 ST4*38mm	X14	F		X4
G	  M4*18mm	X4	H	  ST3*12mm   ST3*10mm	X2
I	  ST3*16mm	X14	J		X68
K		X12	L		X2
M	 	X4	N		X1
O	 	X2	R	 ST3.5*10mm	X6

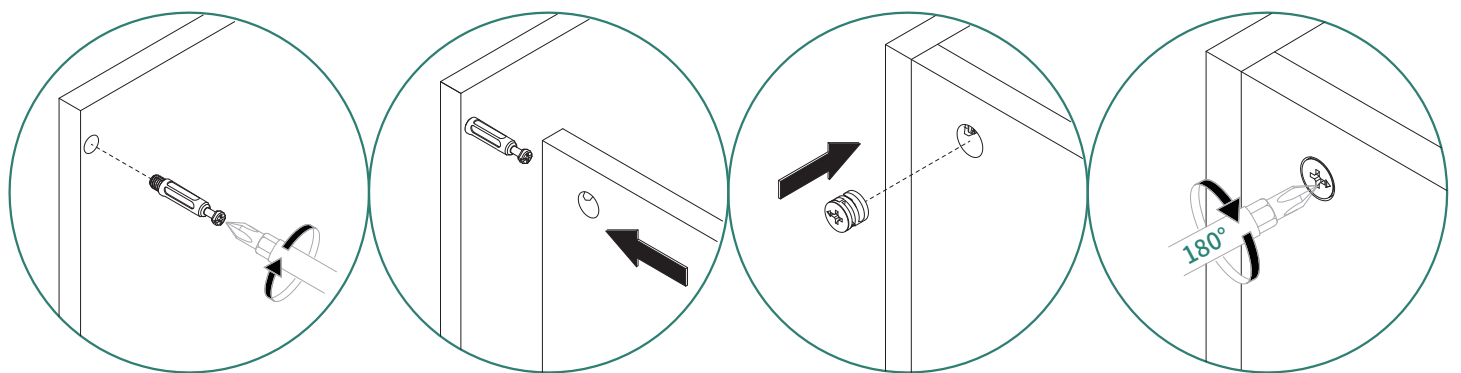
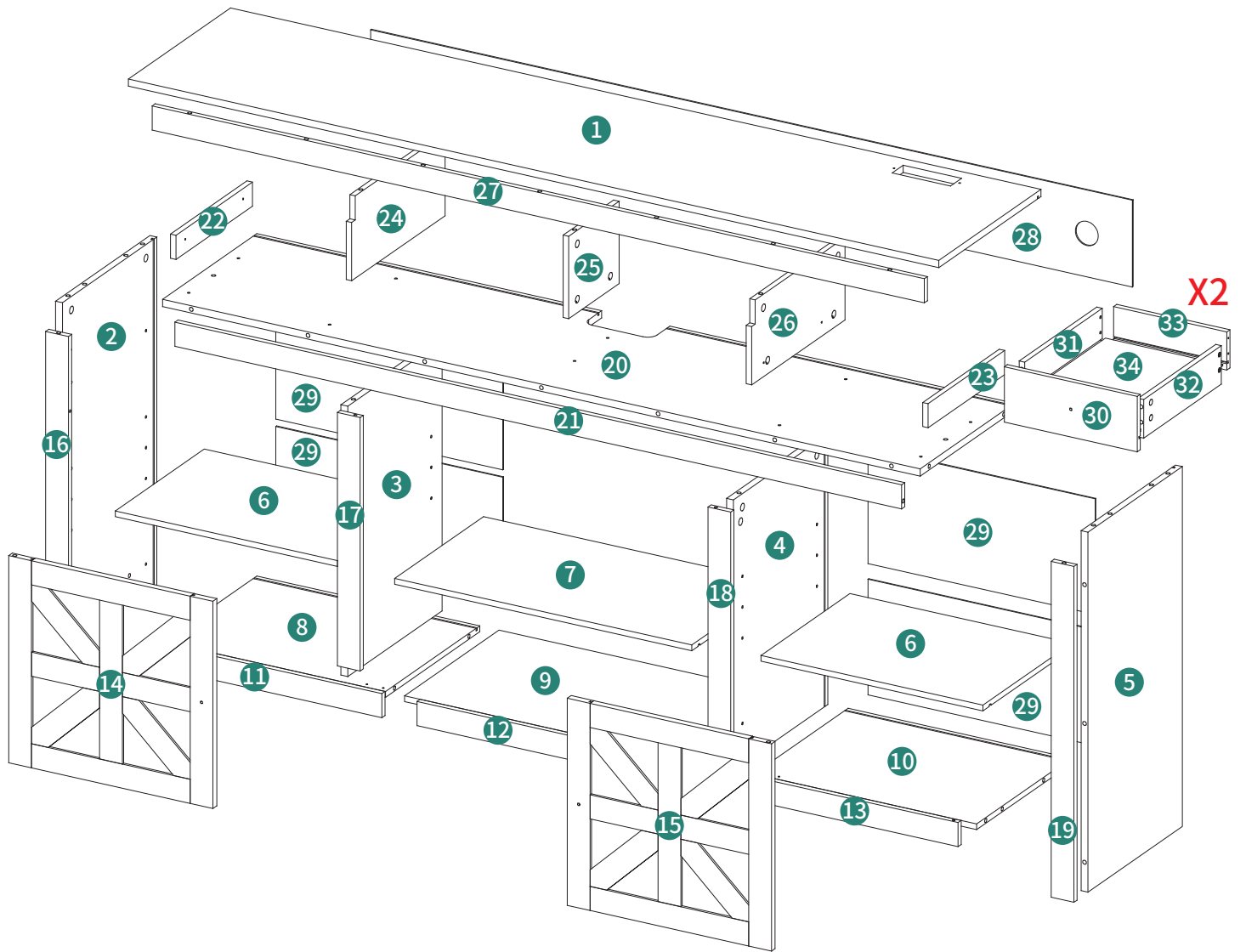

# 1

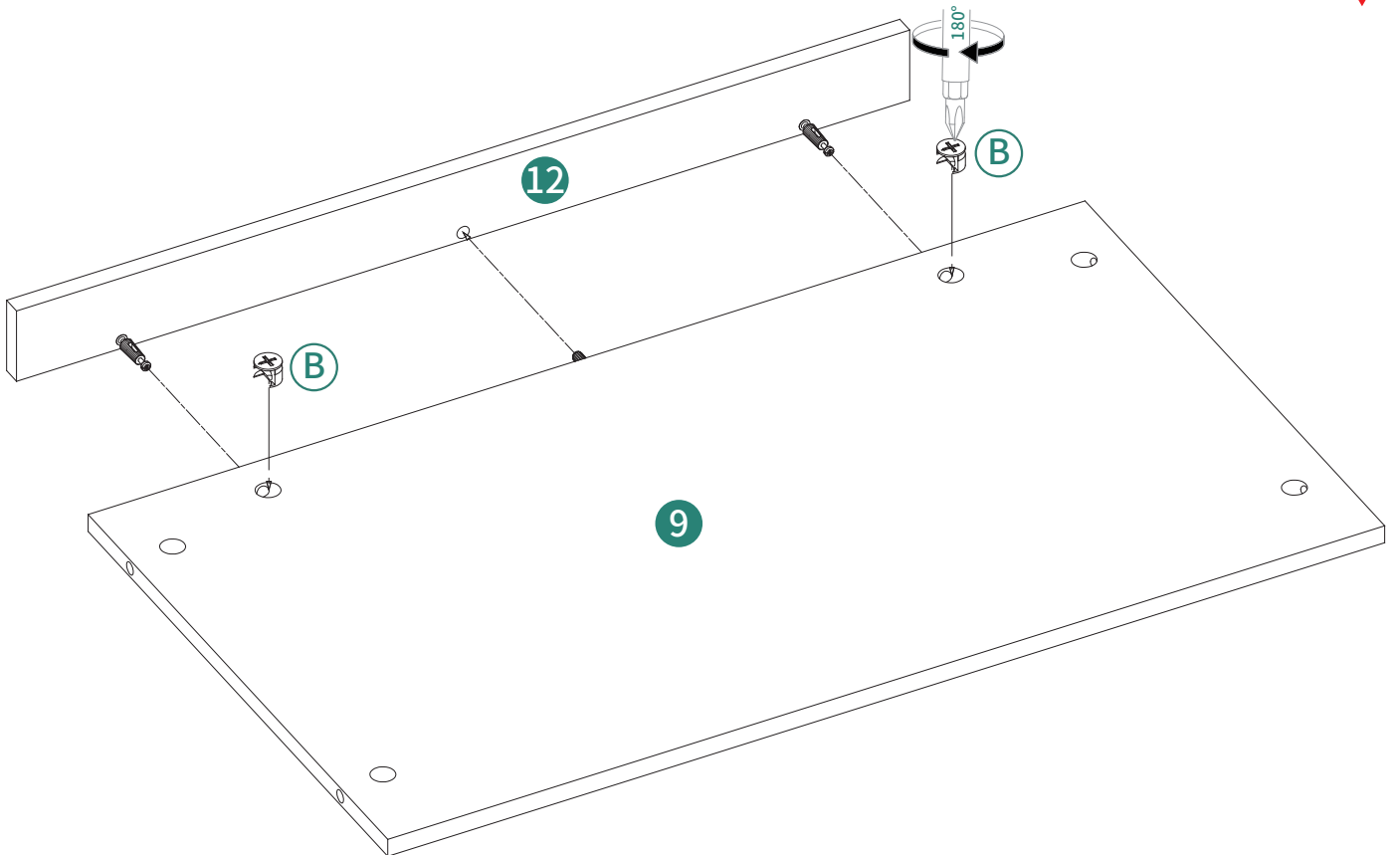
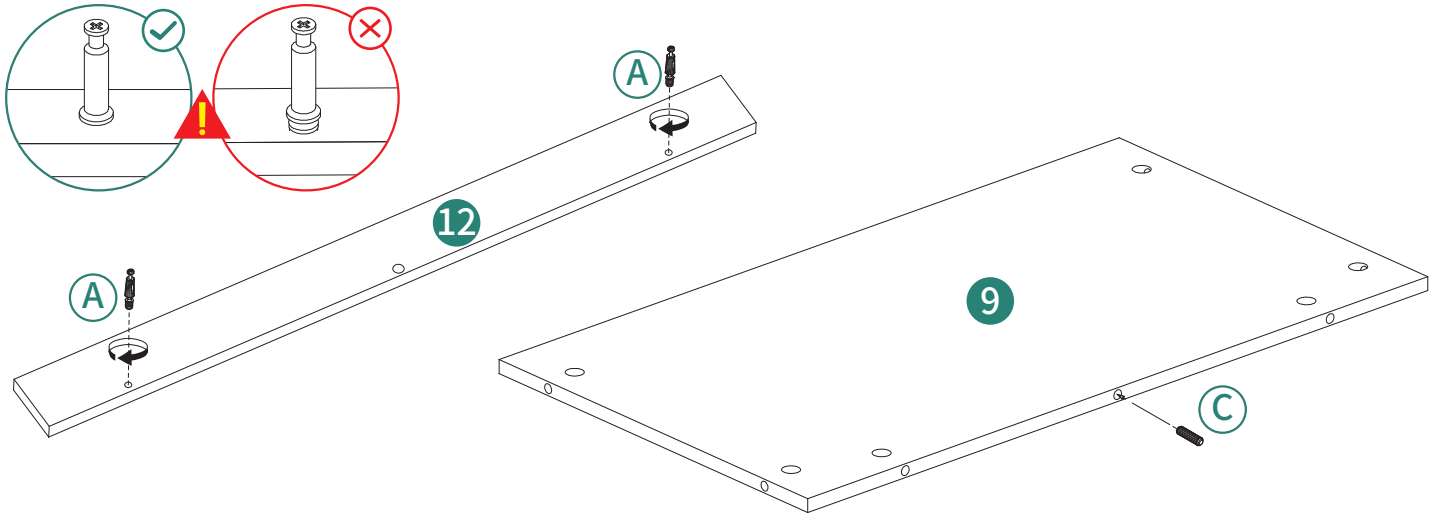
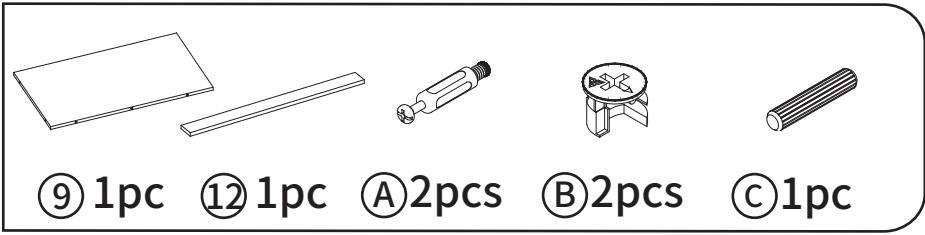

# 2

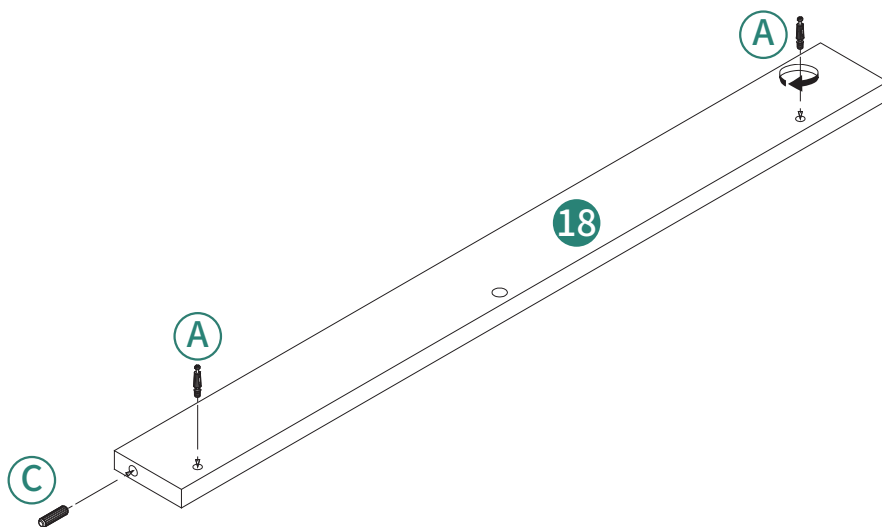
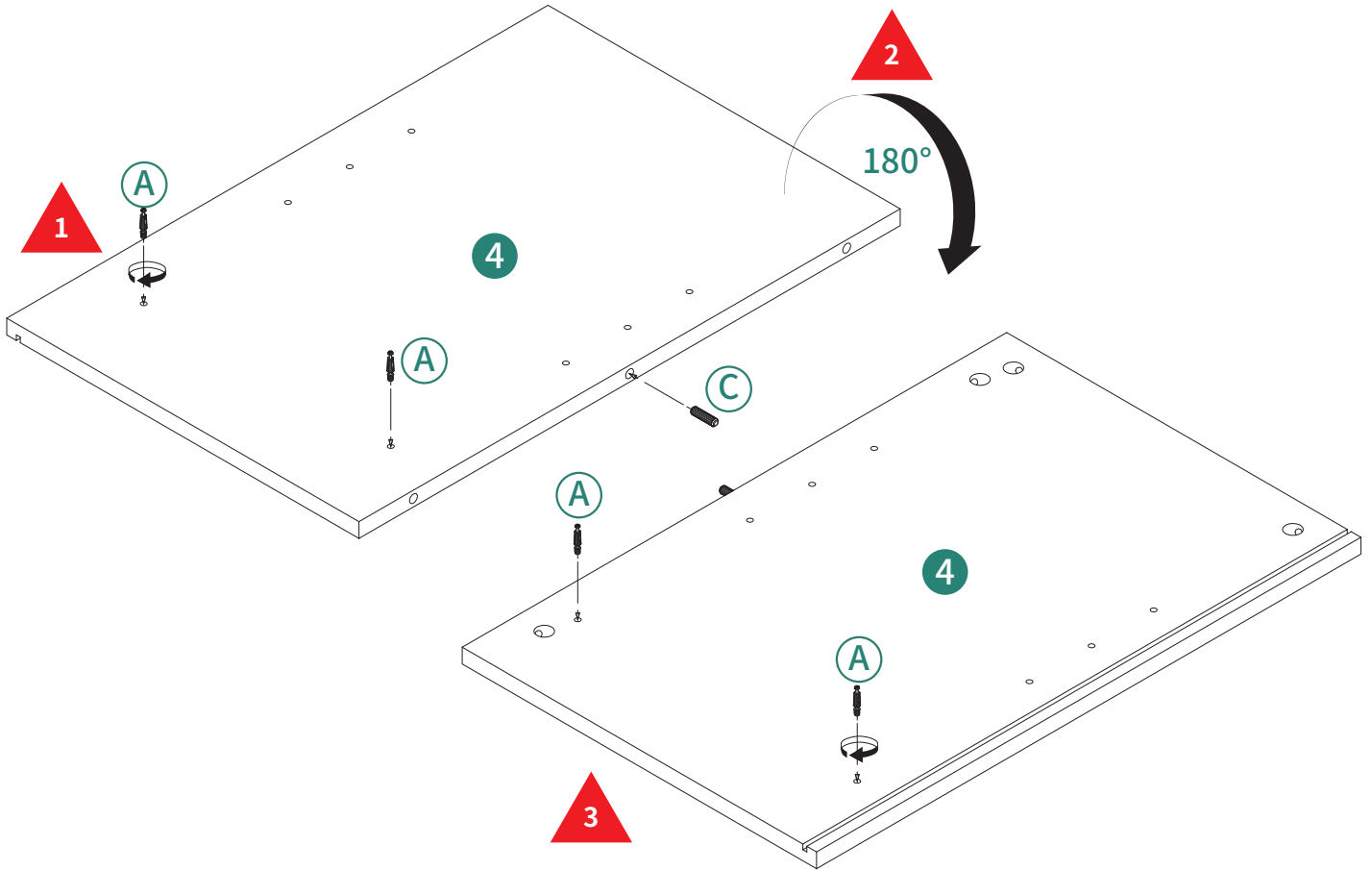
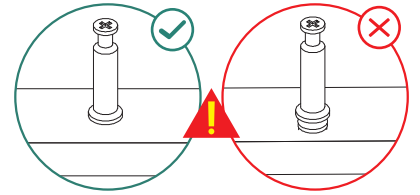
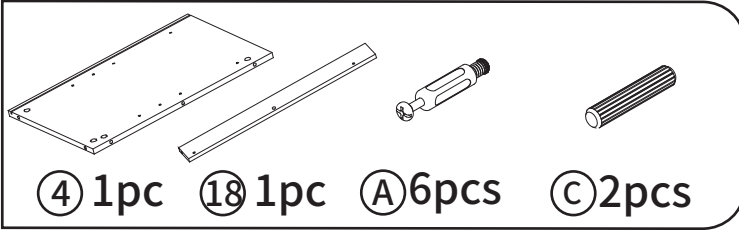

# 3

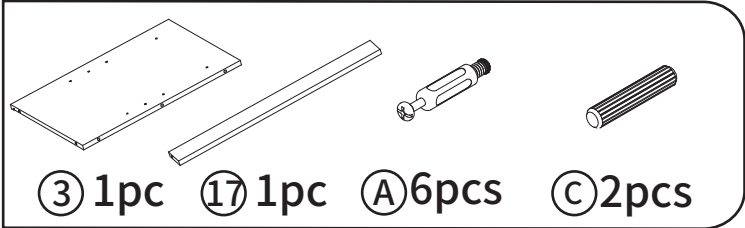

③ 1pc   ①⑦ 1pc   ① 6pcs   ① 2pcs

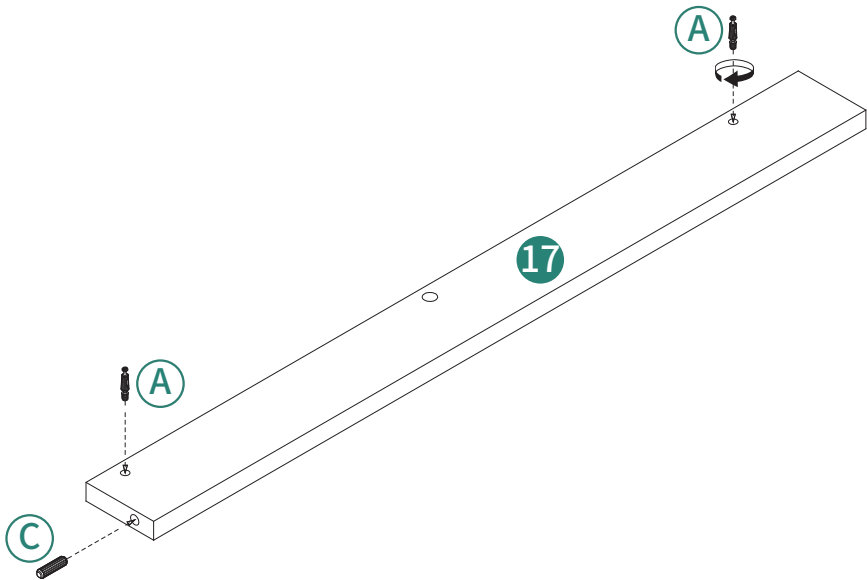
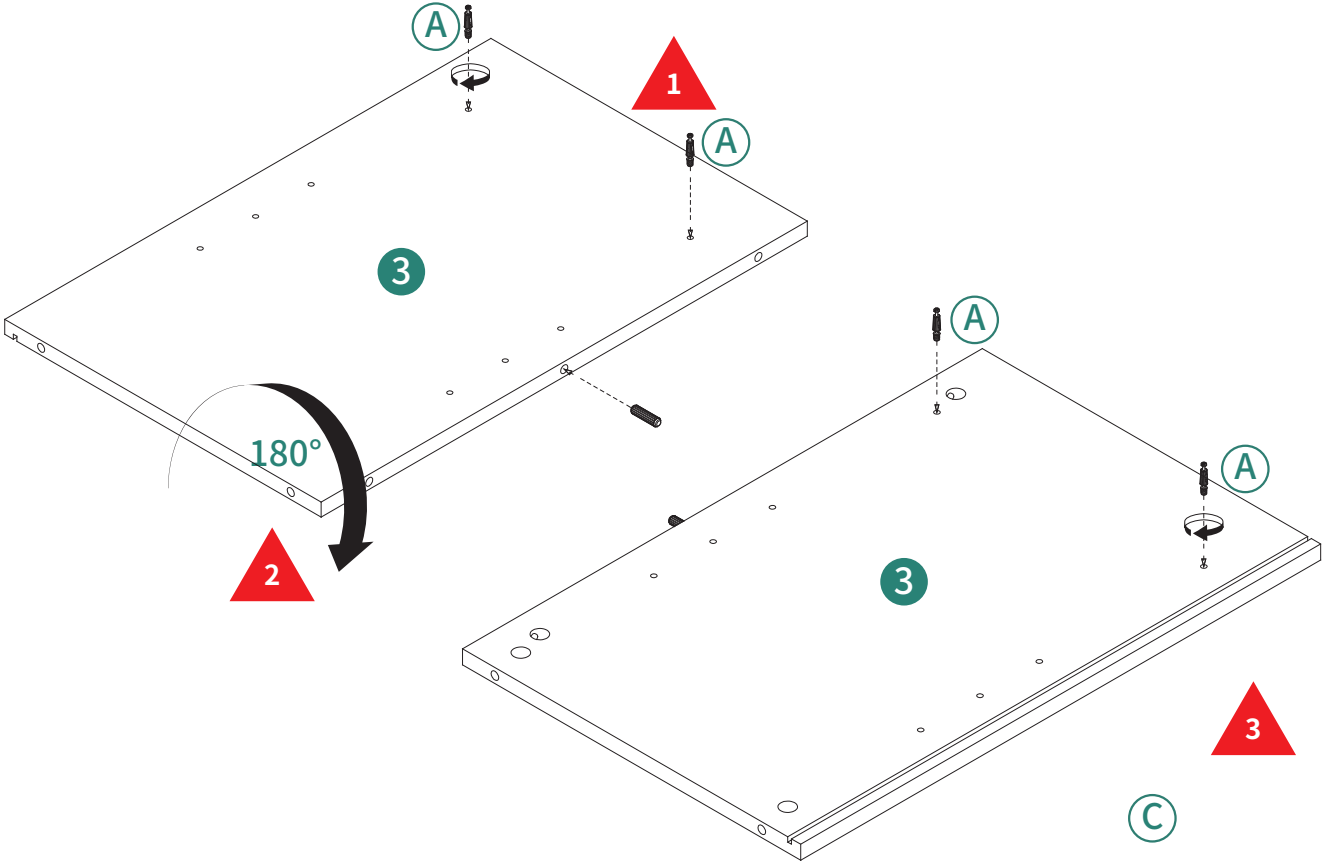
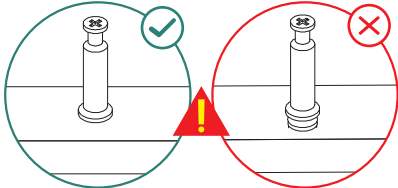

4

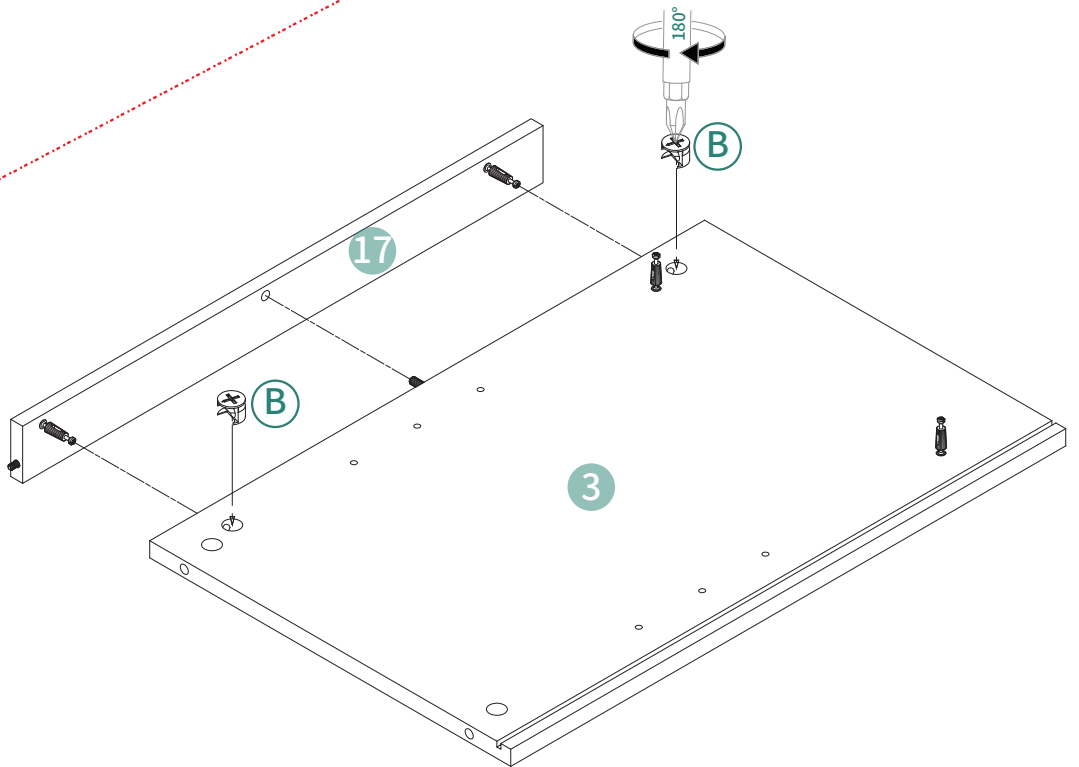
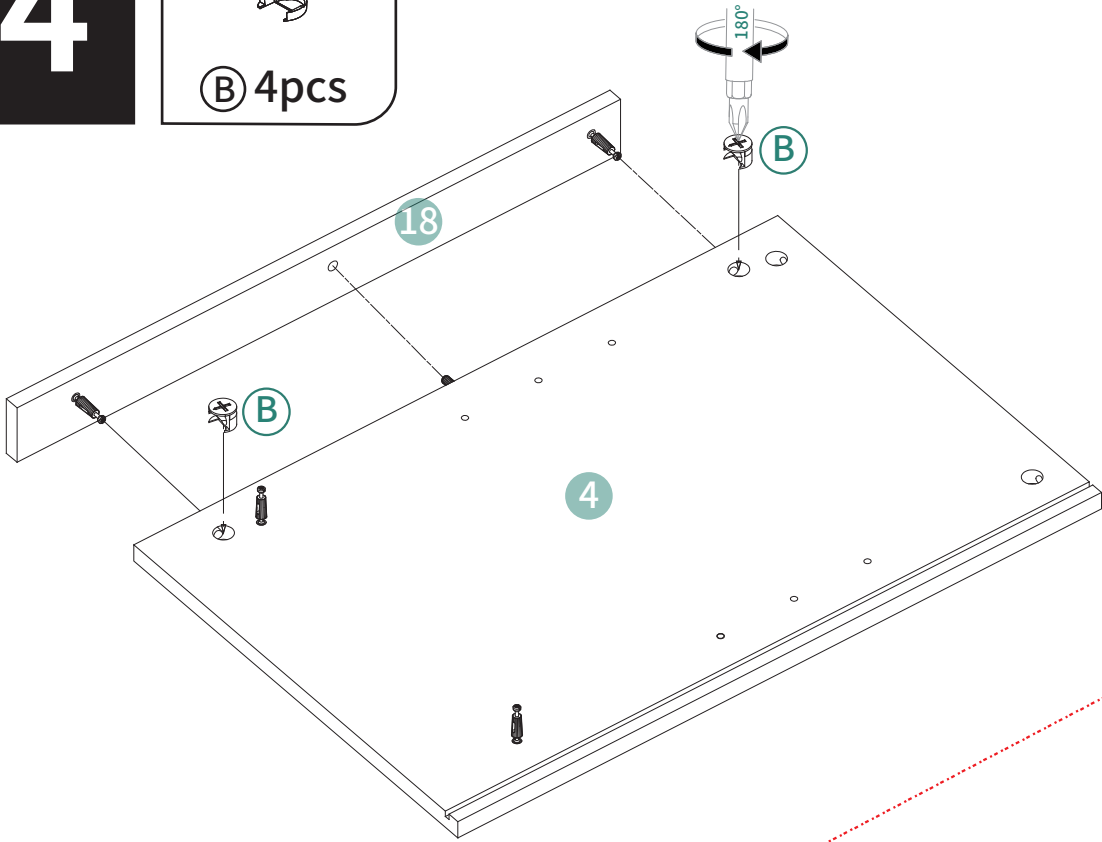
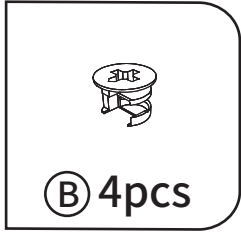

5

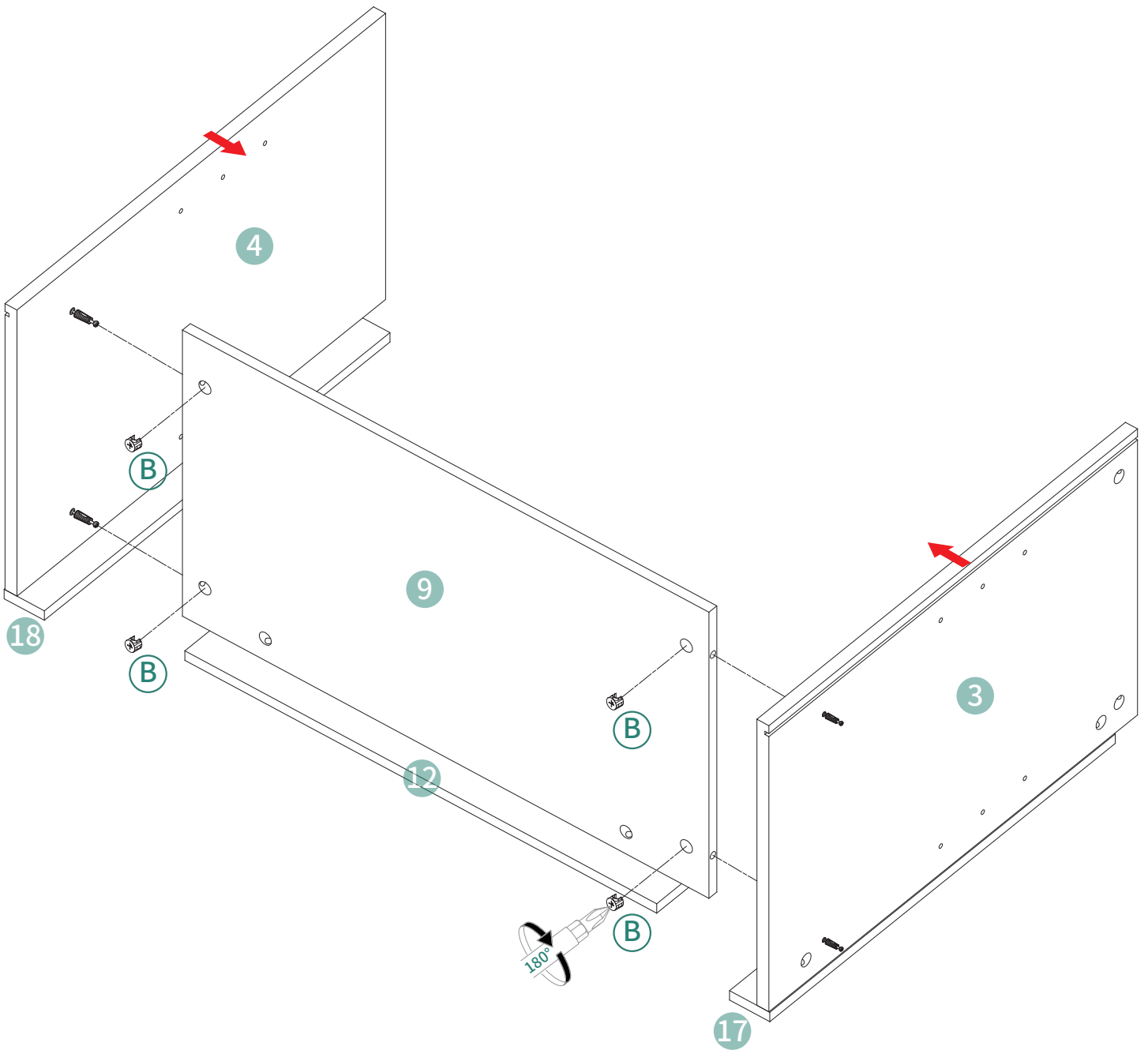
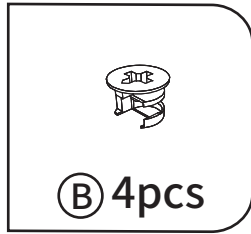

# 6



②0 1pc ②1 1pc ① 14pcs ③ 5pcs

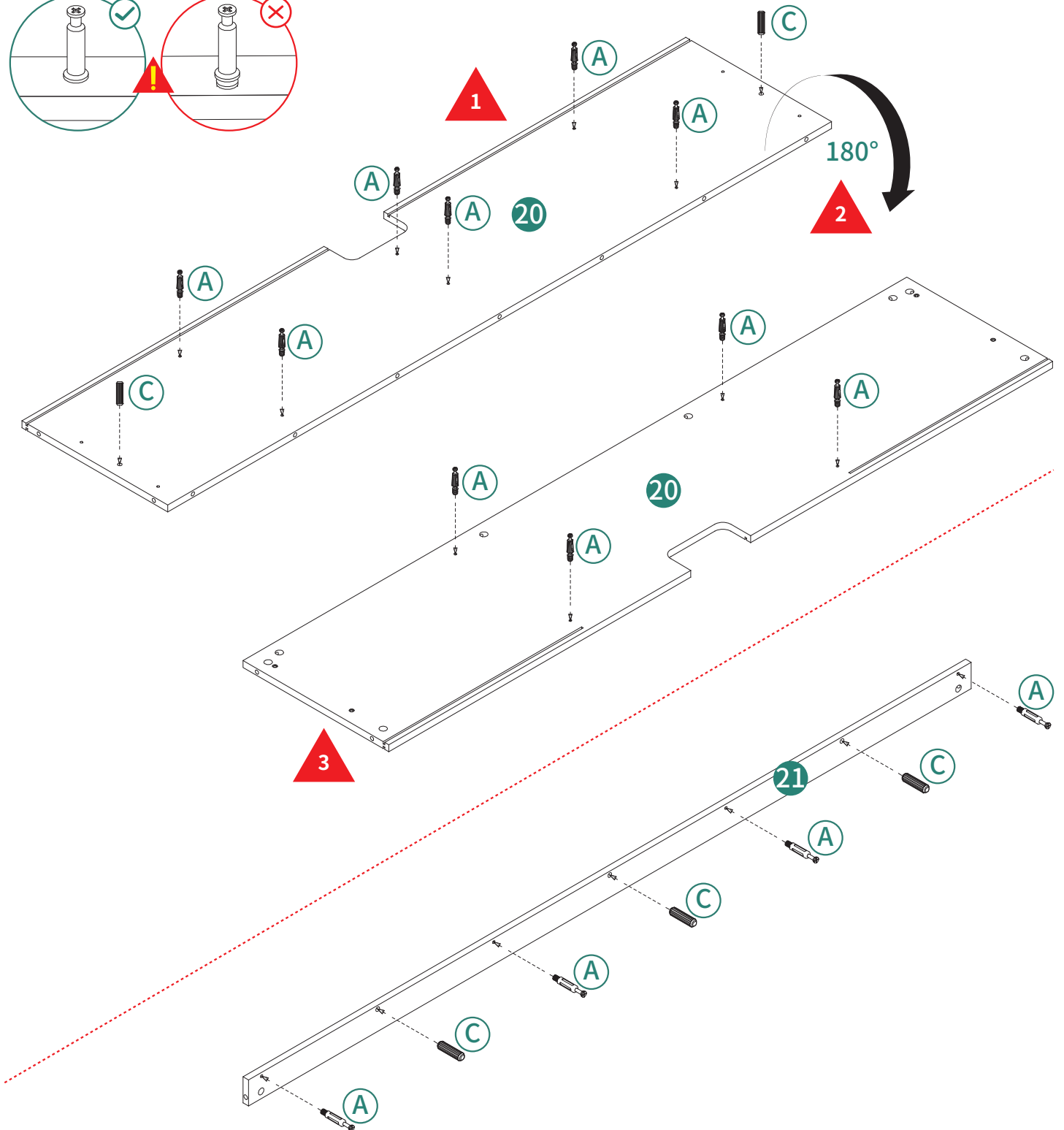
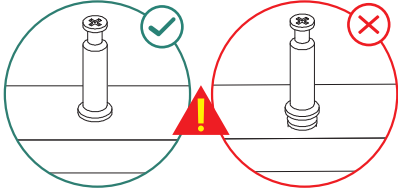

# 7

②②1pc ②③1pc ②B 4pcs ②E 4pcs

ST4\*38mm

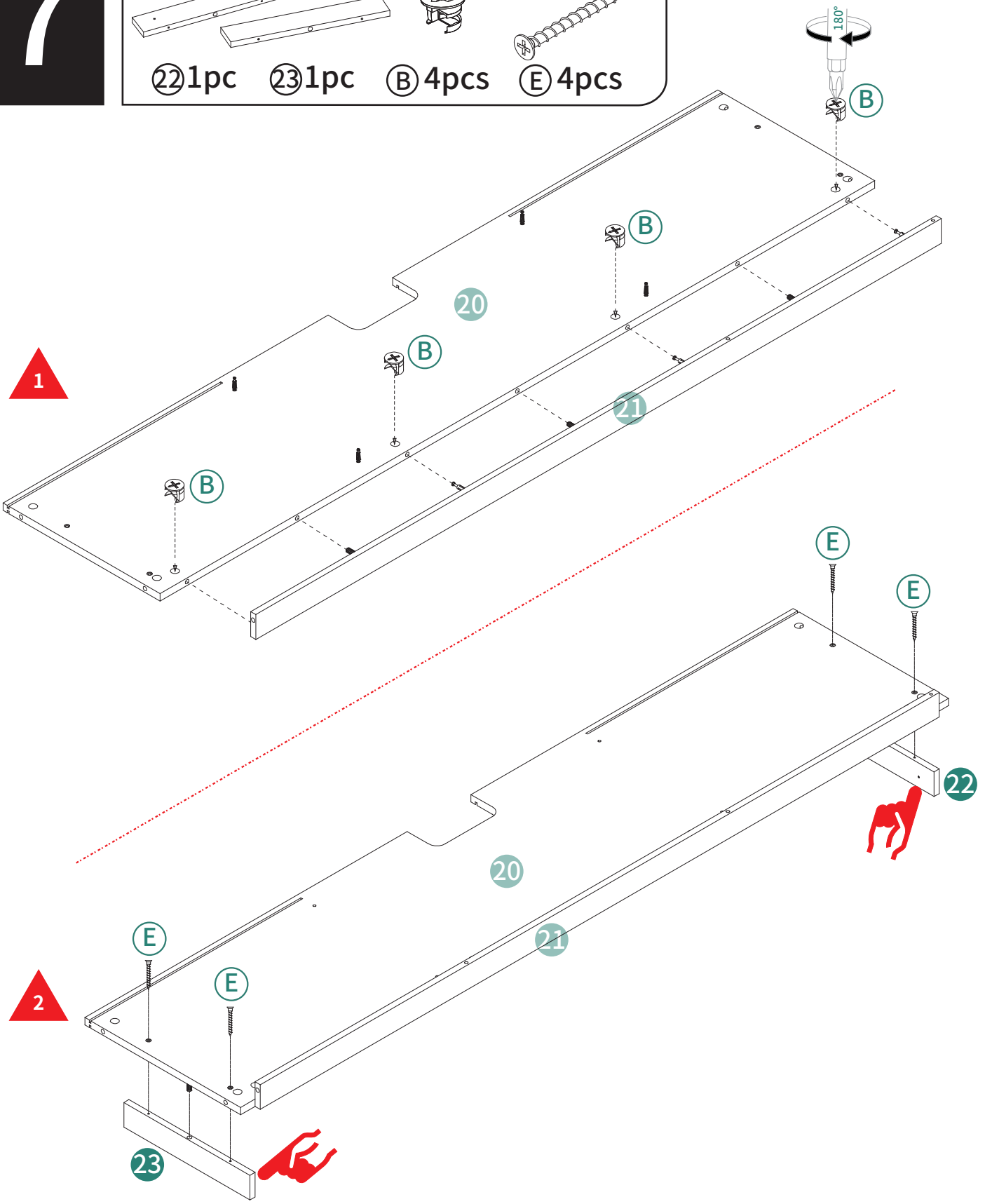
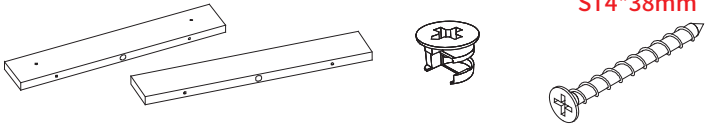

8

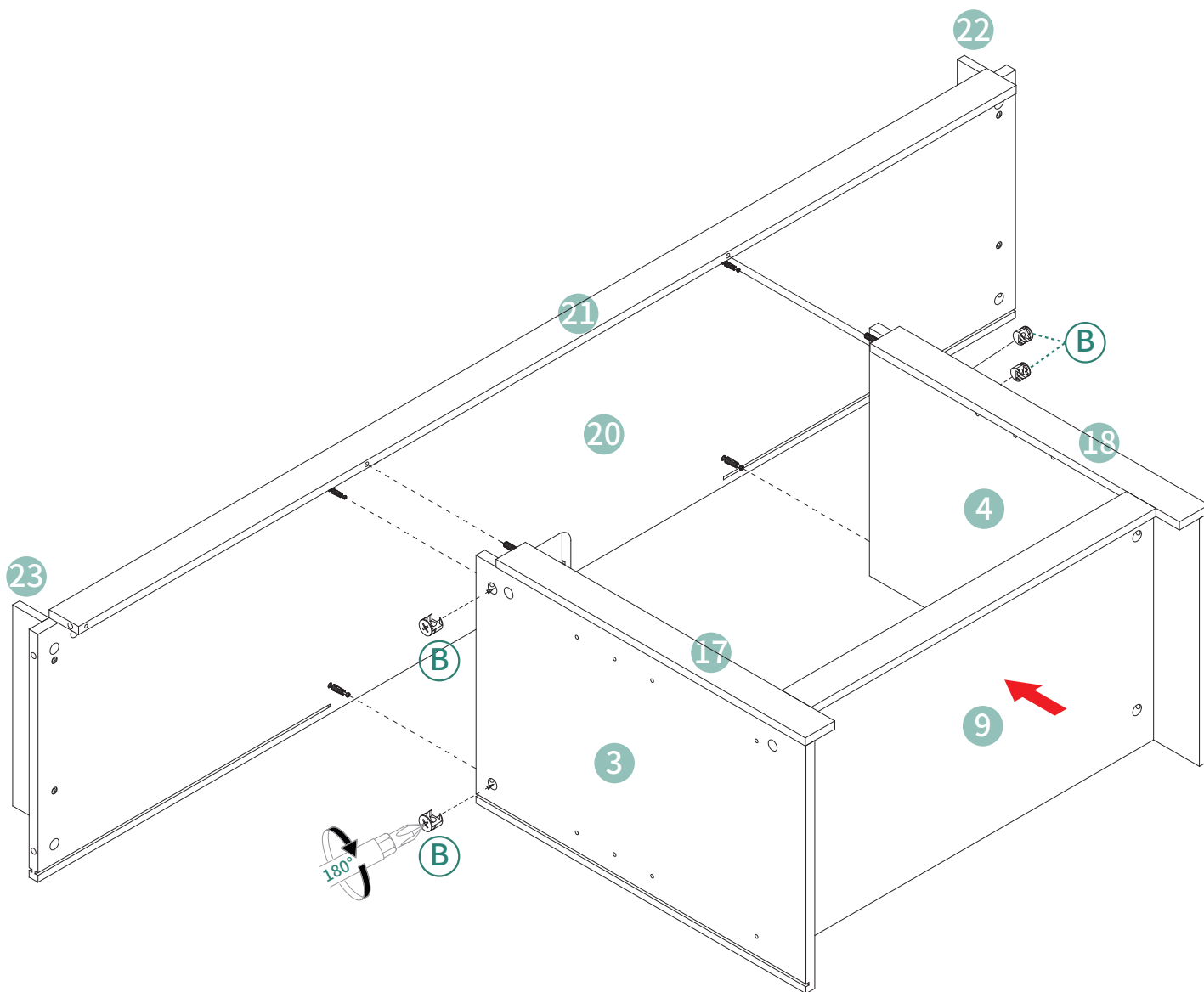
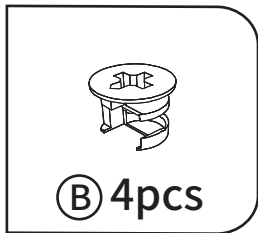

# 9

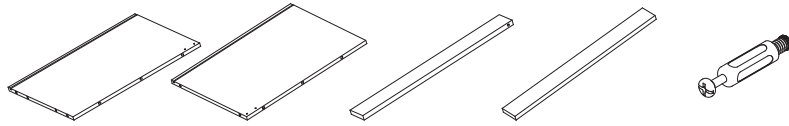

ST3\*12mm



① 2pcs

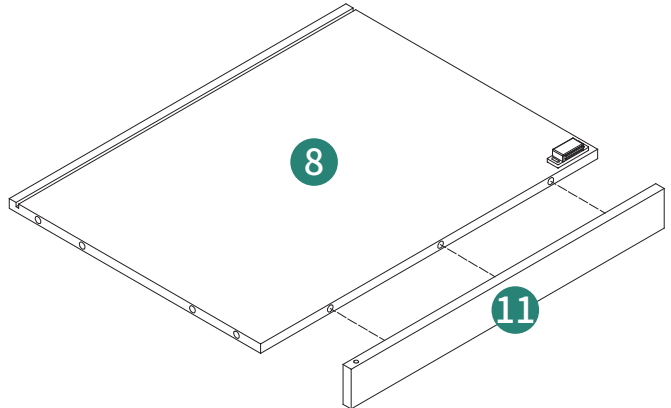
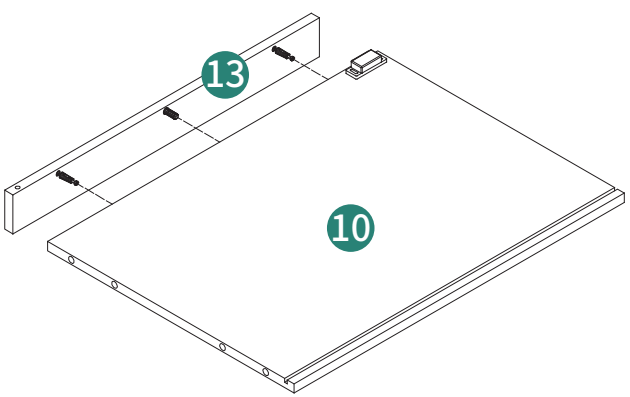
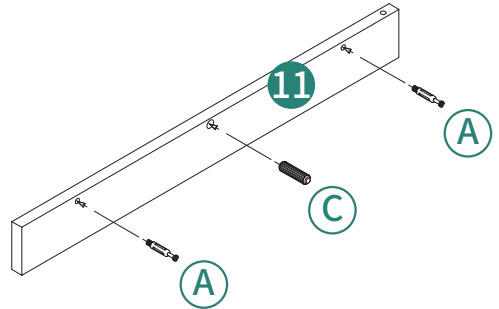
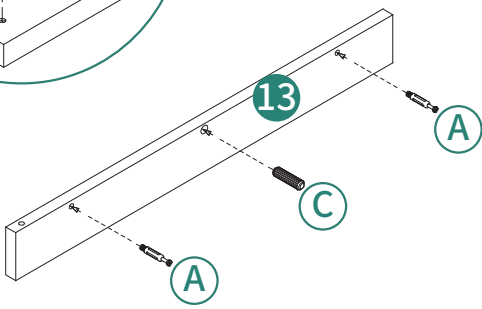
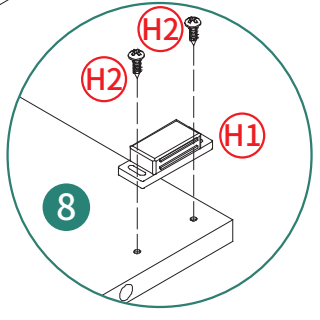
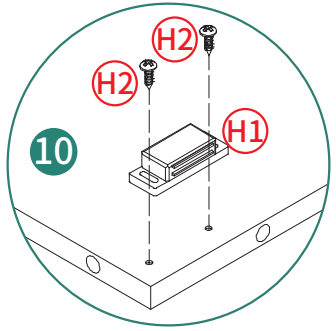
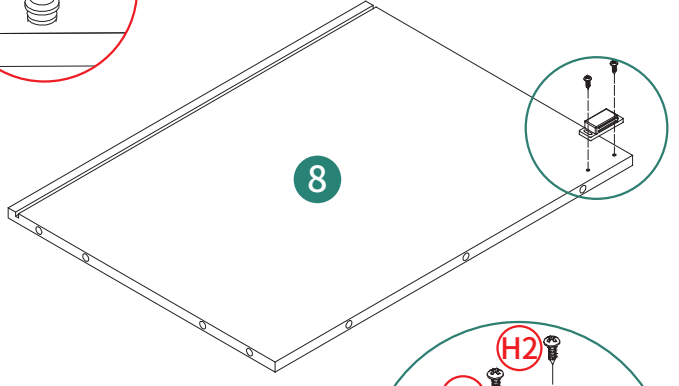
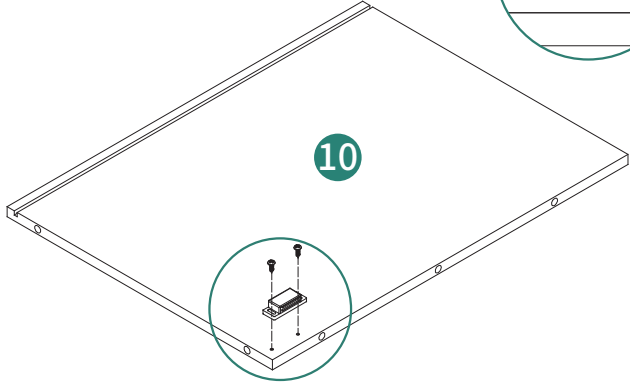
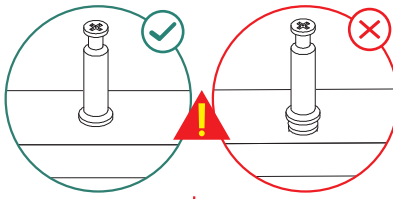

# 10

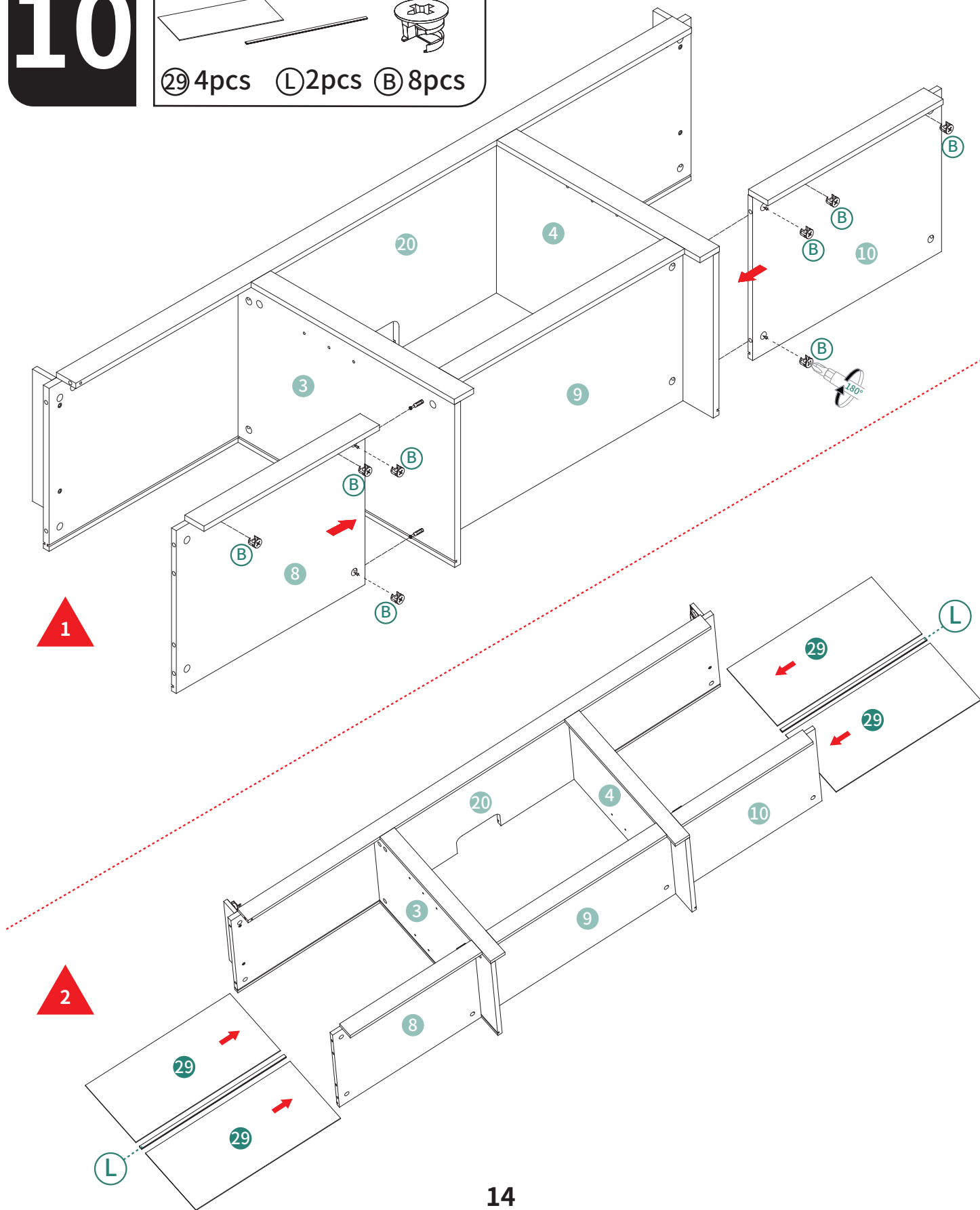
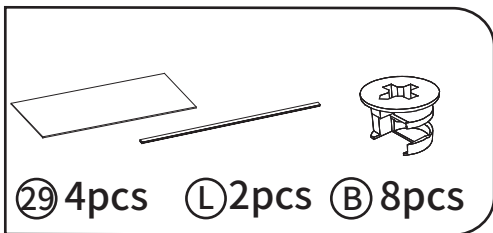

# 11

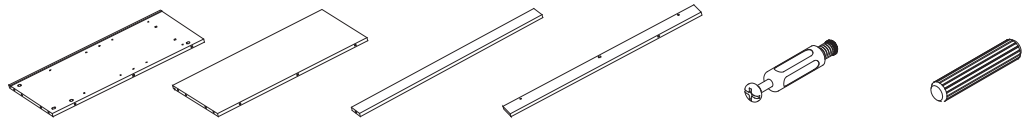

② 1pc   ⑤ 1pc   ①⑥ 1pc   ①⑨ 1pc   ① 14pcs   ③ 8pcs

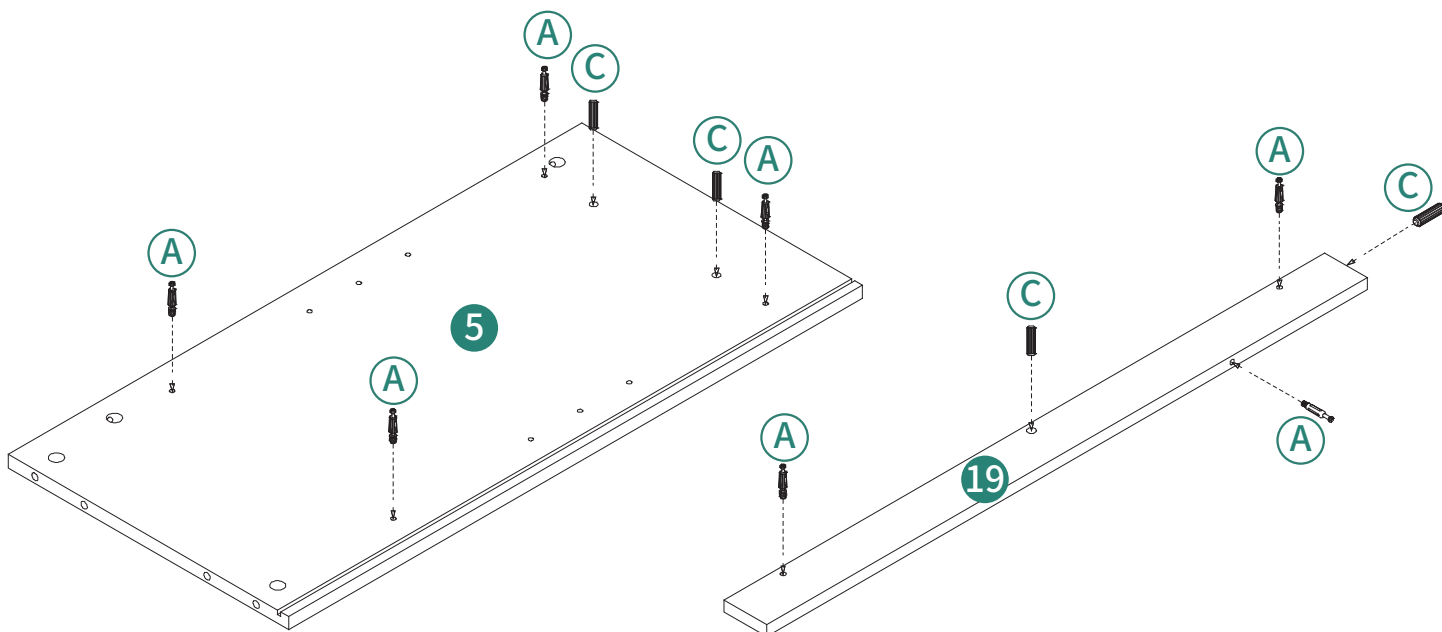
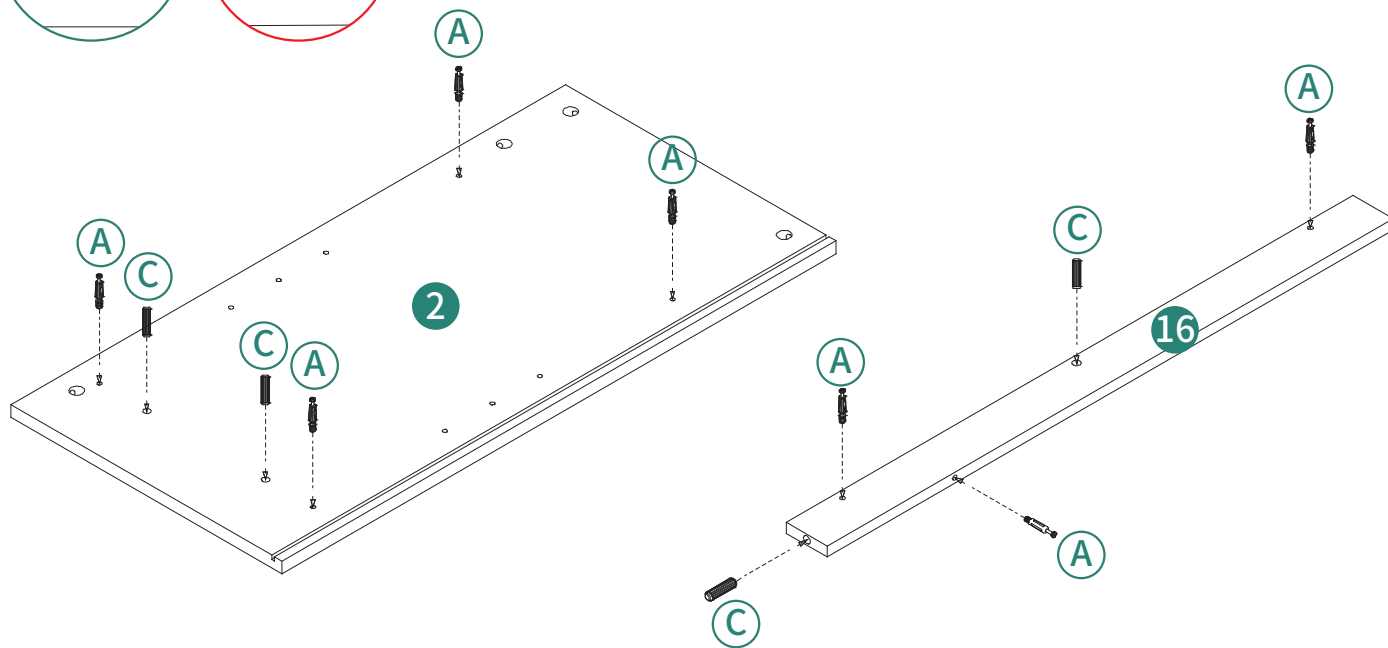
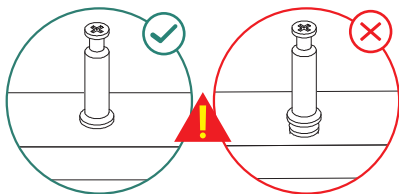

# 12

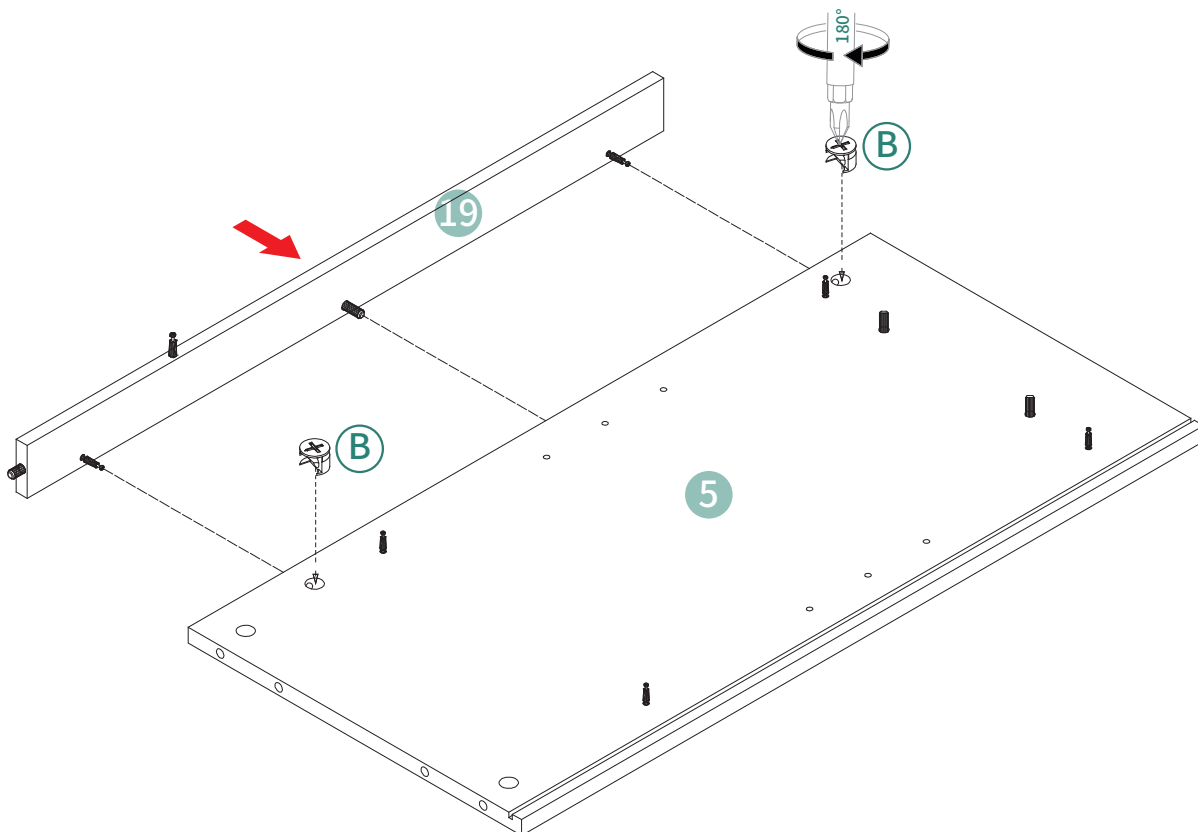
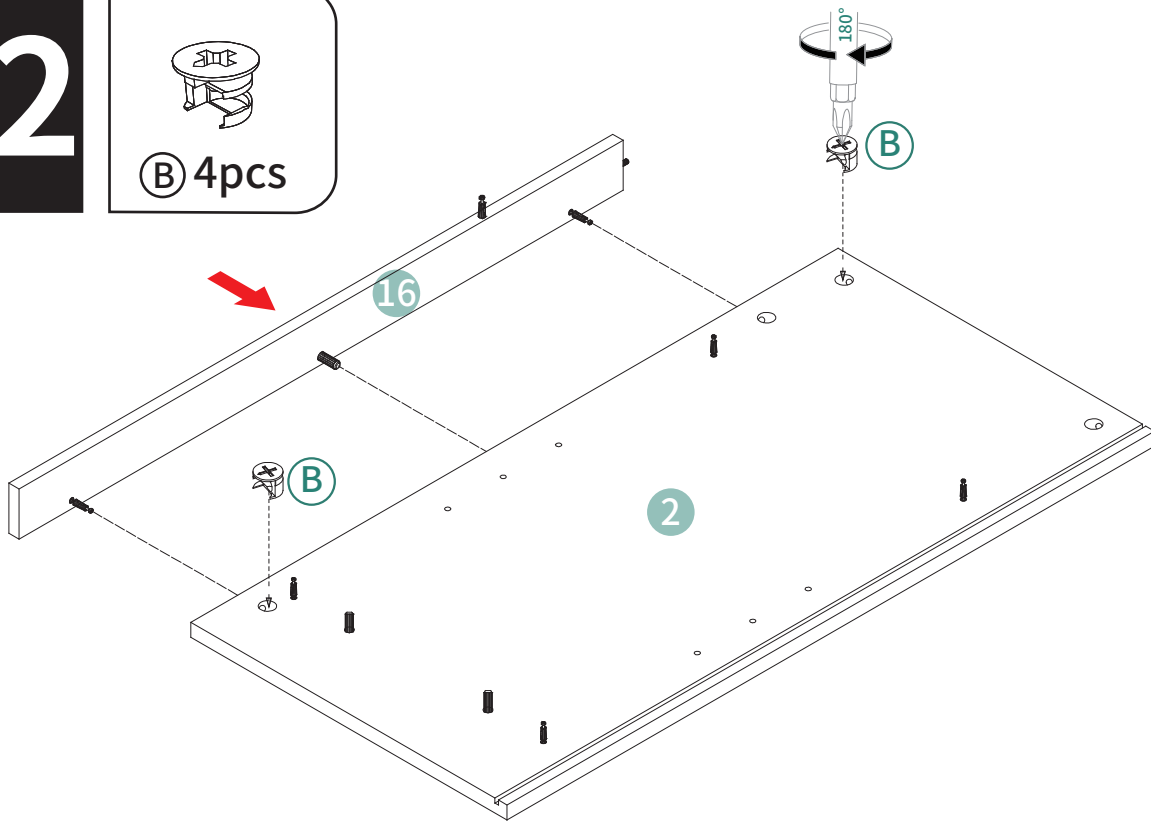
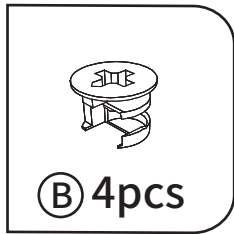

13



(B) 10pcs

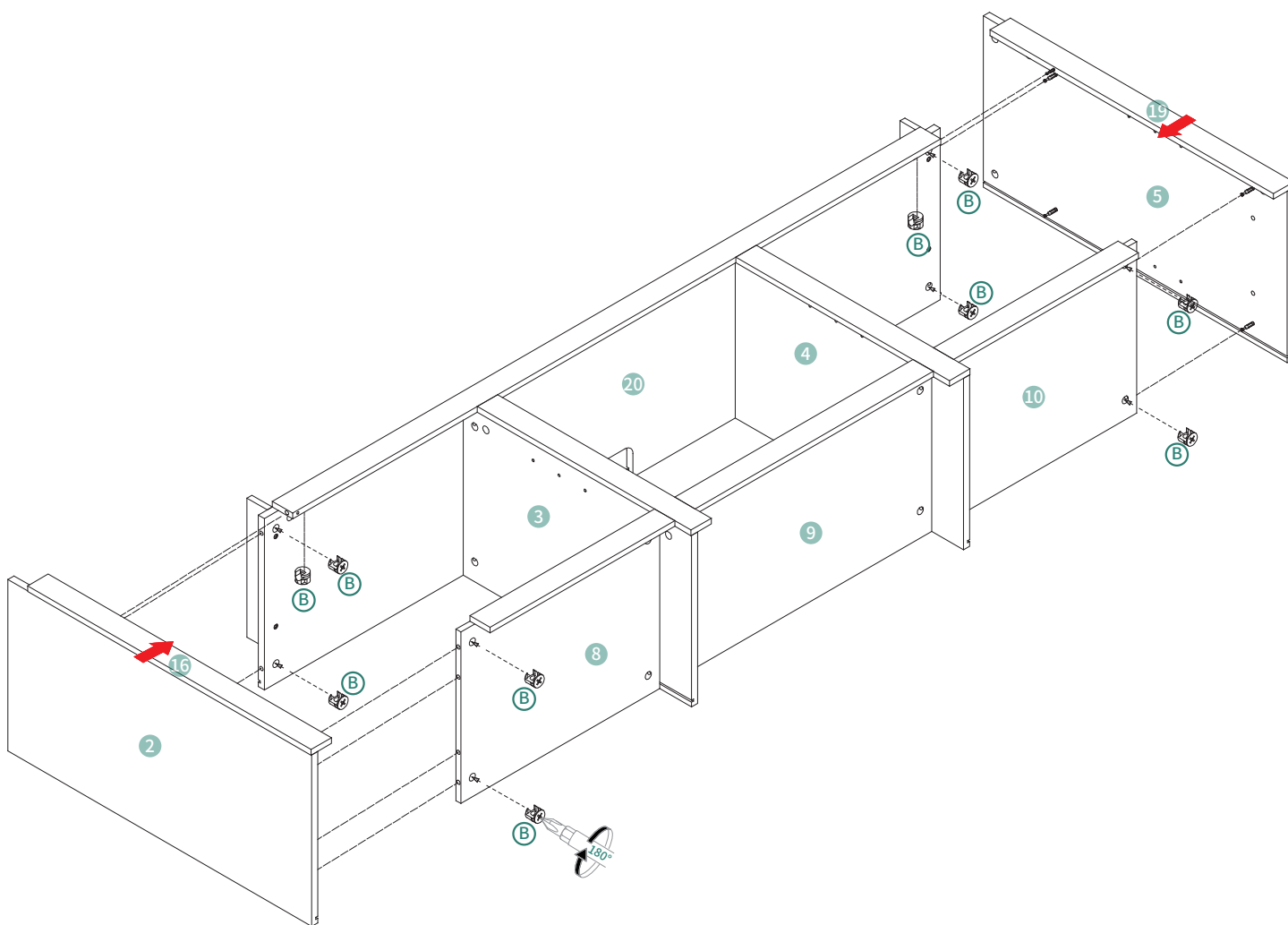

# 14

ST3.5\*14mm

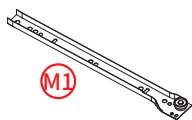

ⓓ 4pcs Ⓜ 2pcs

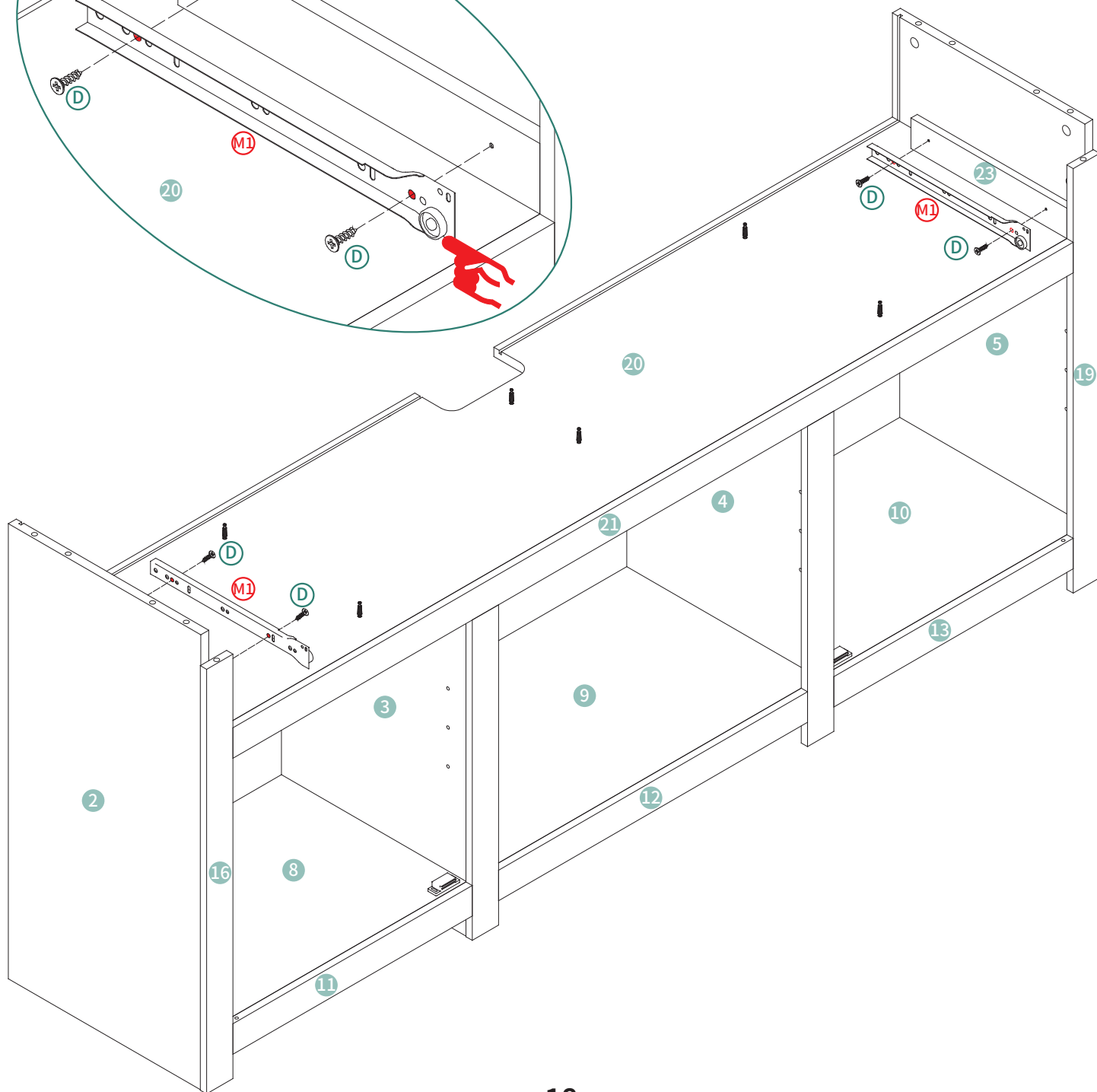
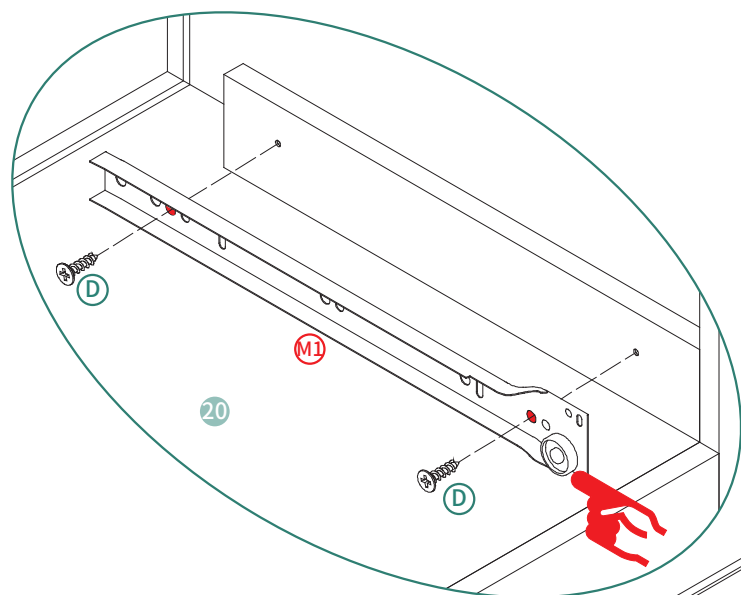

# 15

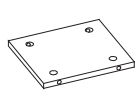

②4 1pc

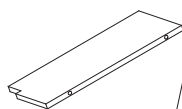

②5 1pc

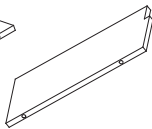

②6 1pc



Ⓑ 6pcs

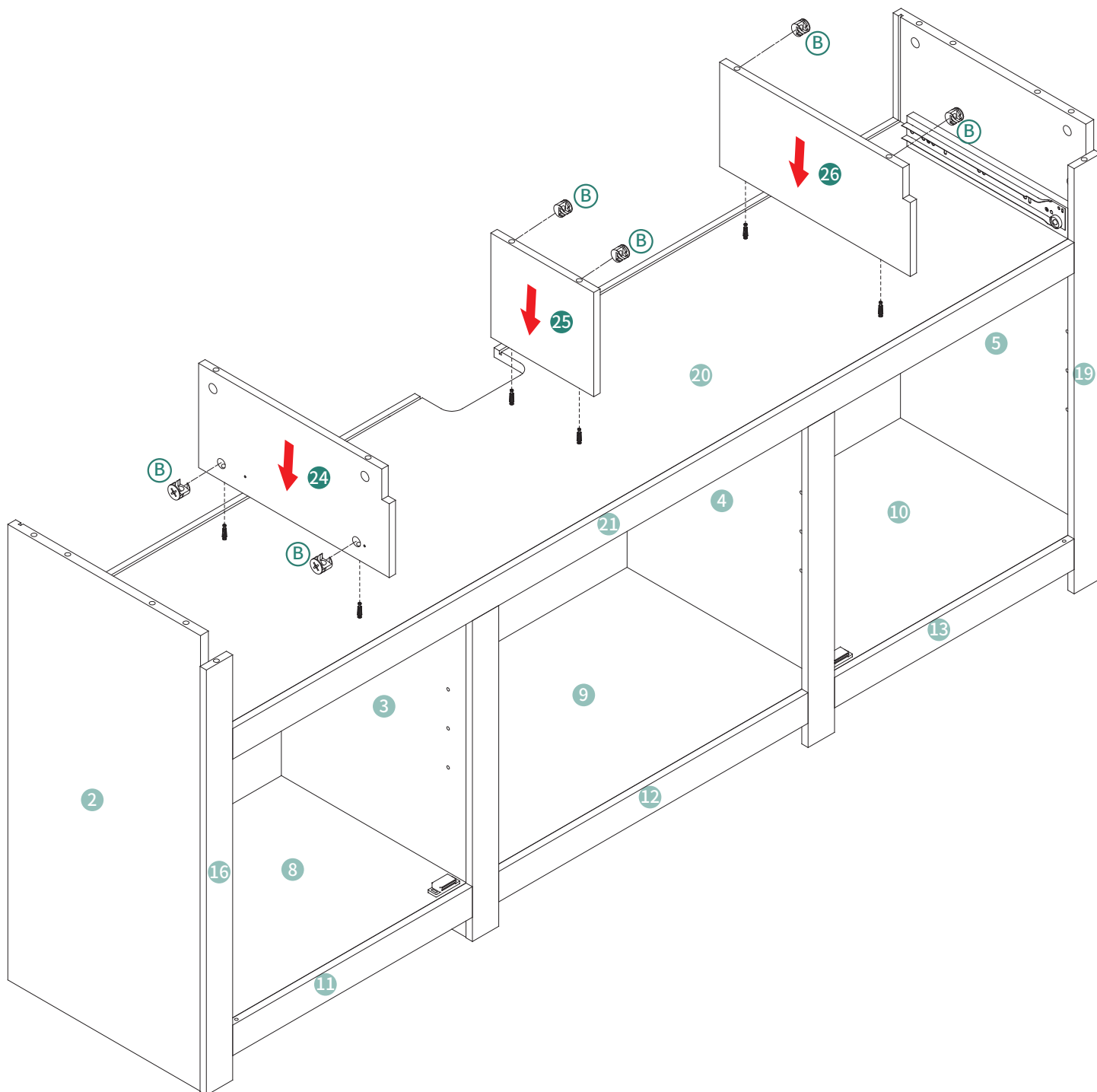

# 16

ST3.5\*14mm



(M1)

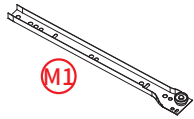

(D) 4pcs (M) 2pcs

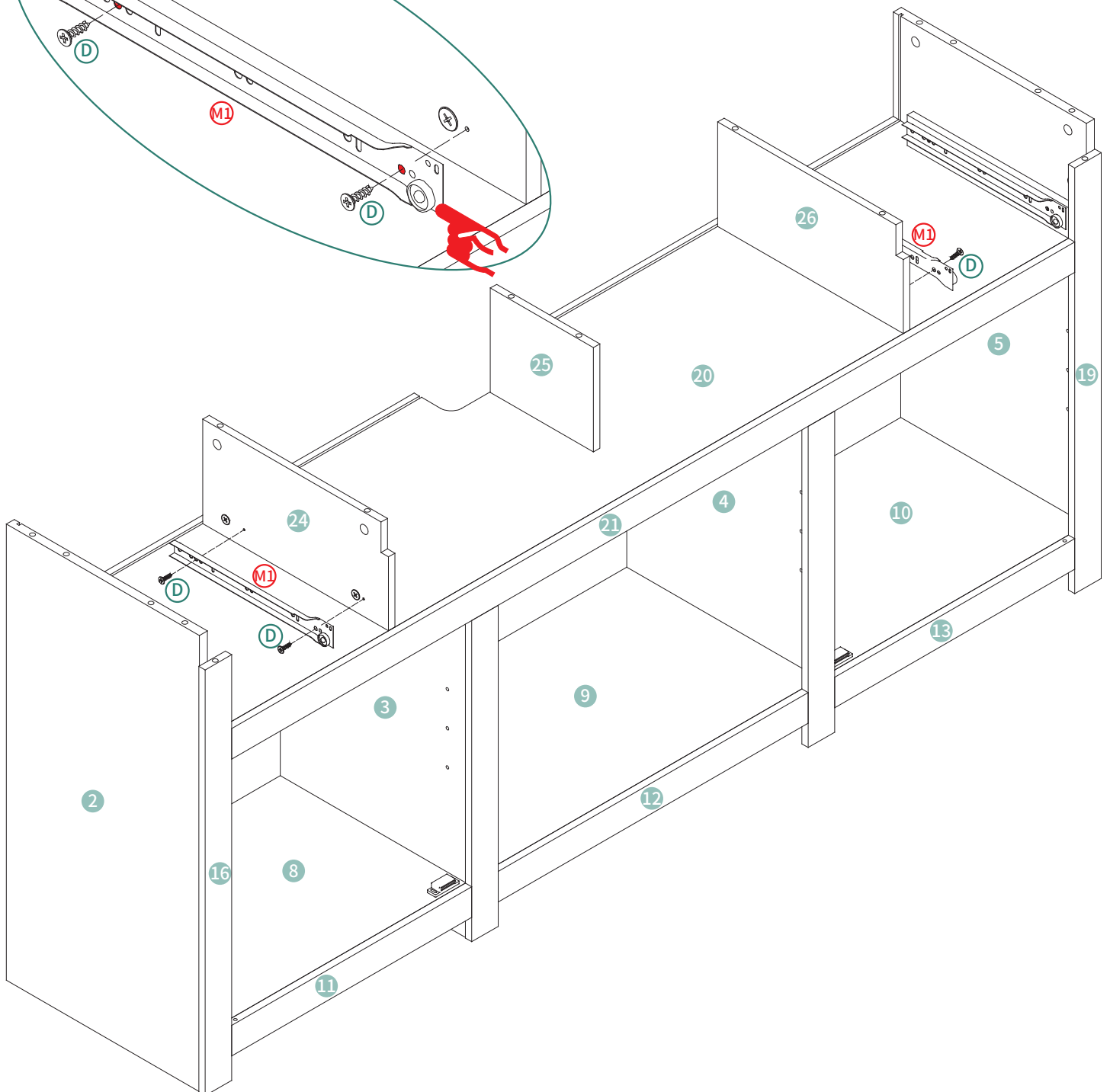
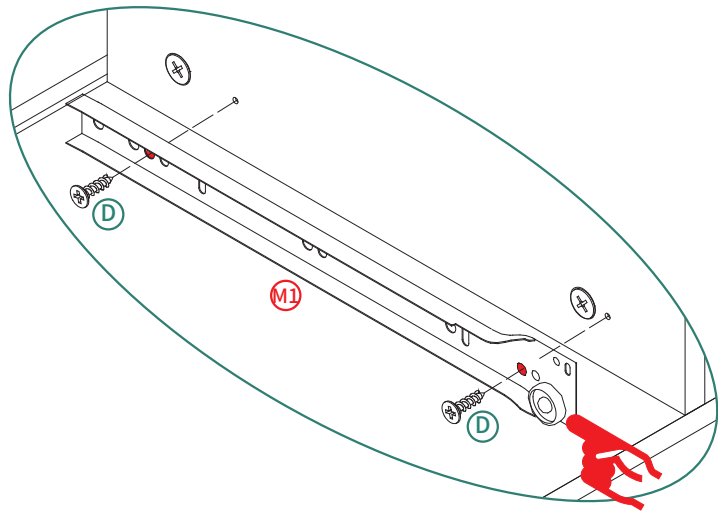



# 18

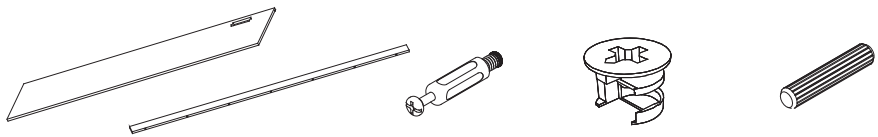

① 1pc ②⑦ 1pc ③A 14pcs ④B 4pcs ⑤C 7pcs

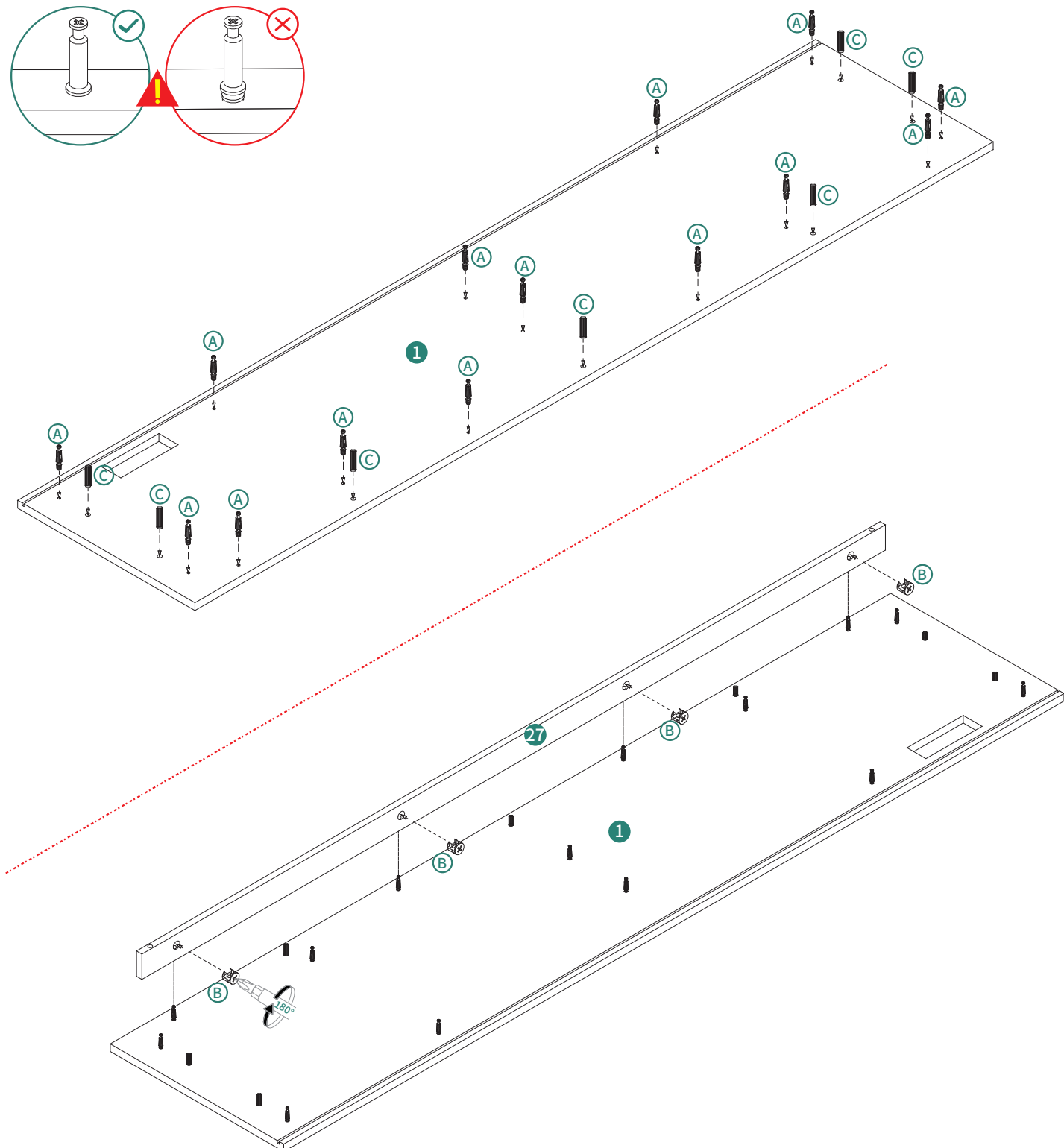
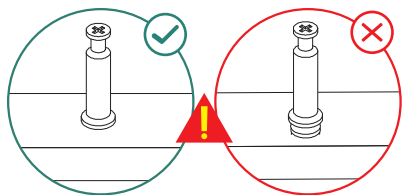

# 19



(B) 10pcs

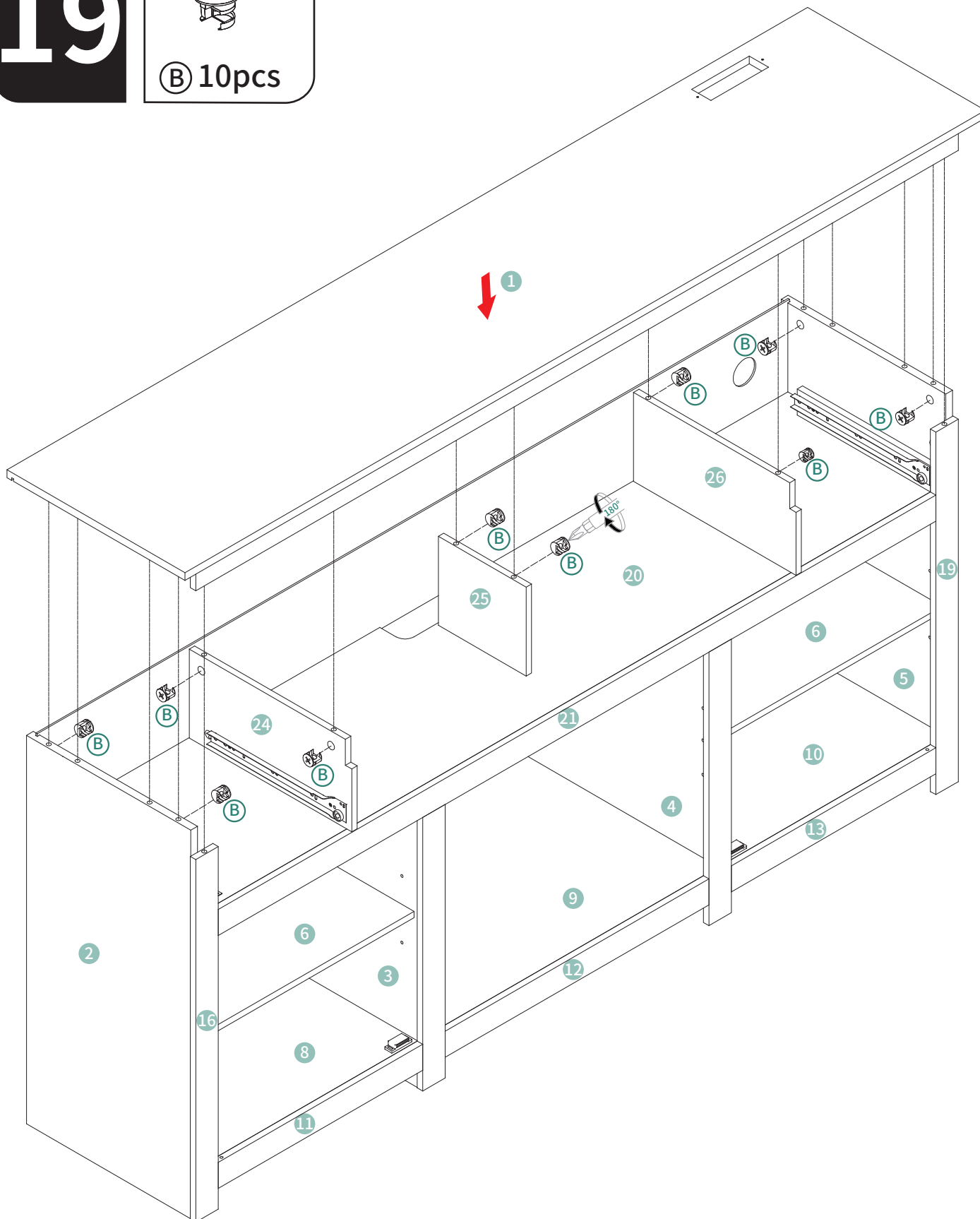

20

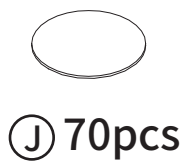

Ⓧ 70pcs

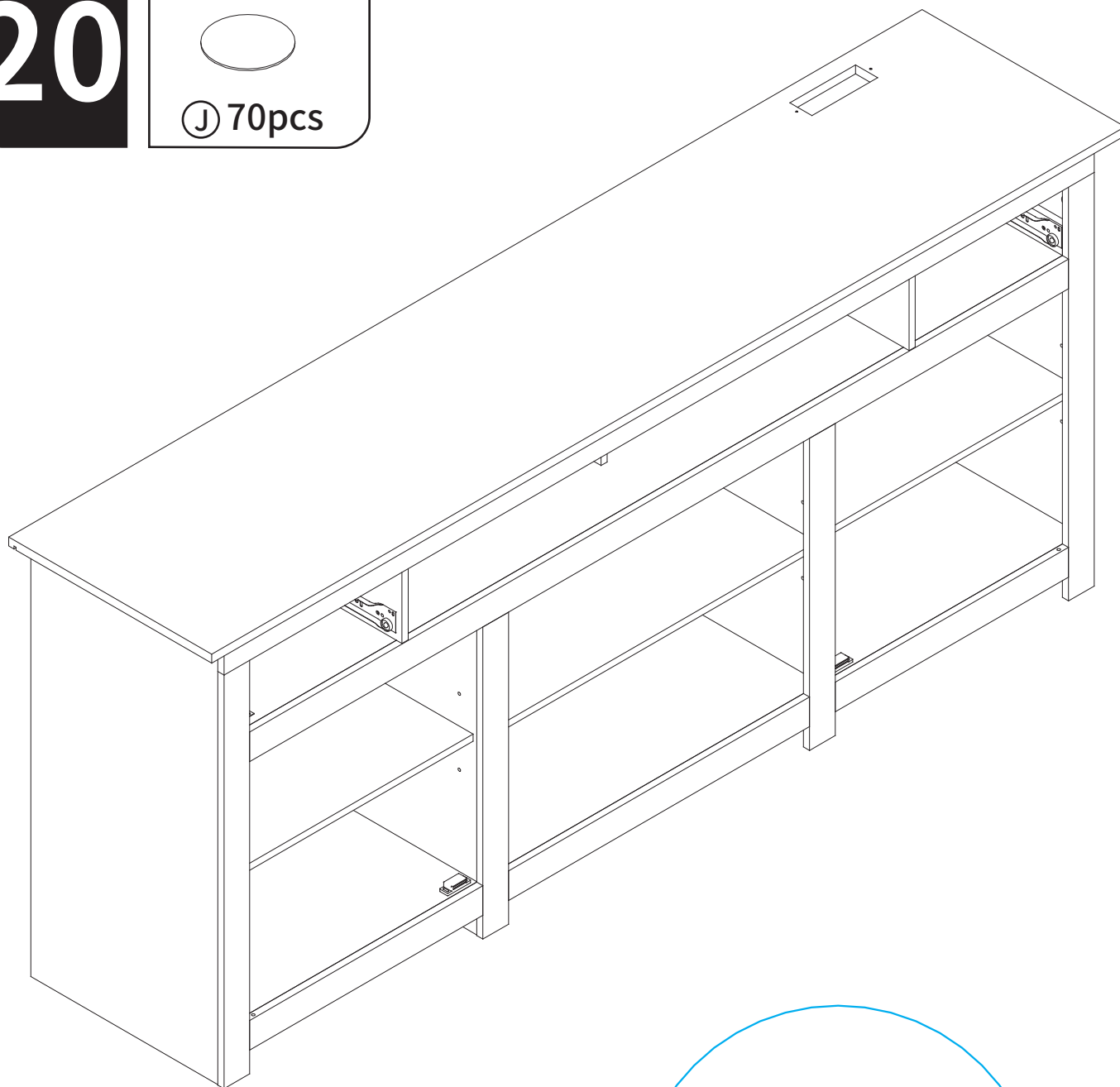

In order to make the product more beautiful,  
please paste hardware J on the exposed holes

Um das Produkt schöner zu gestalten, bitte  
Hardware J auf das freiliegende Loch kleben.

Pour rendre le produit plus beau, veuillez coller  
la pièce J sur le trou exposé.

Per rendere il prodotto più bello, si prega di incollare  
l'hardware J sul foro esposto.

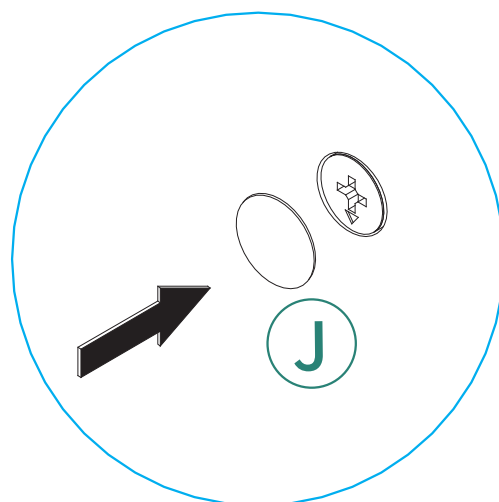

# 21

## X2

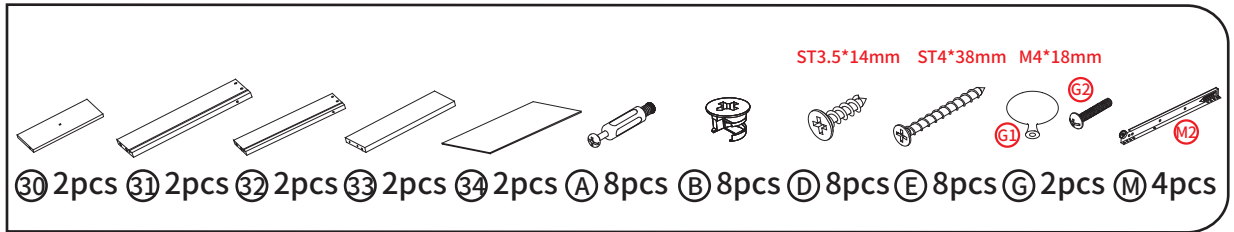

Note: Make sure the positions marked by triangles are facing the same direction.

Hinweis: Stellen Sie sicher, dass die Positionen, die durch Dreiecke markiert sind, in die gleiche Richtung zeigen.



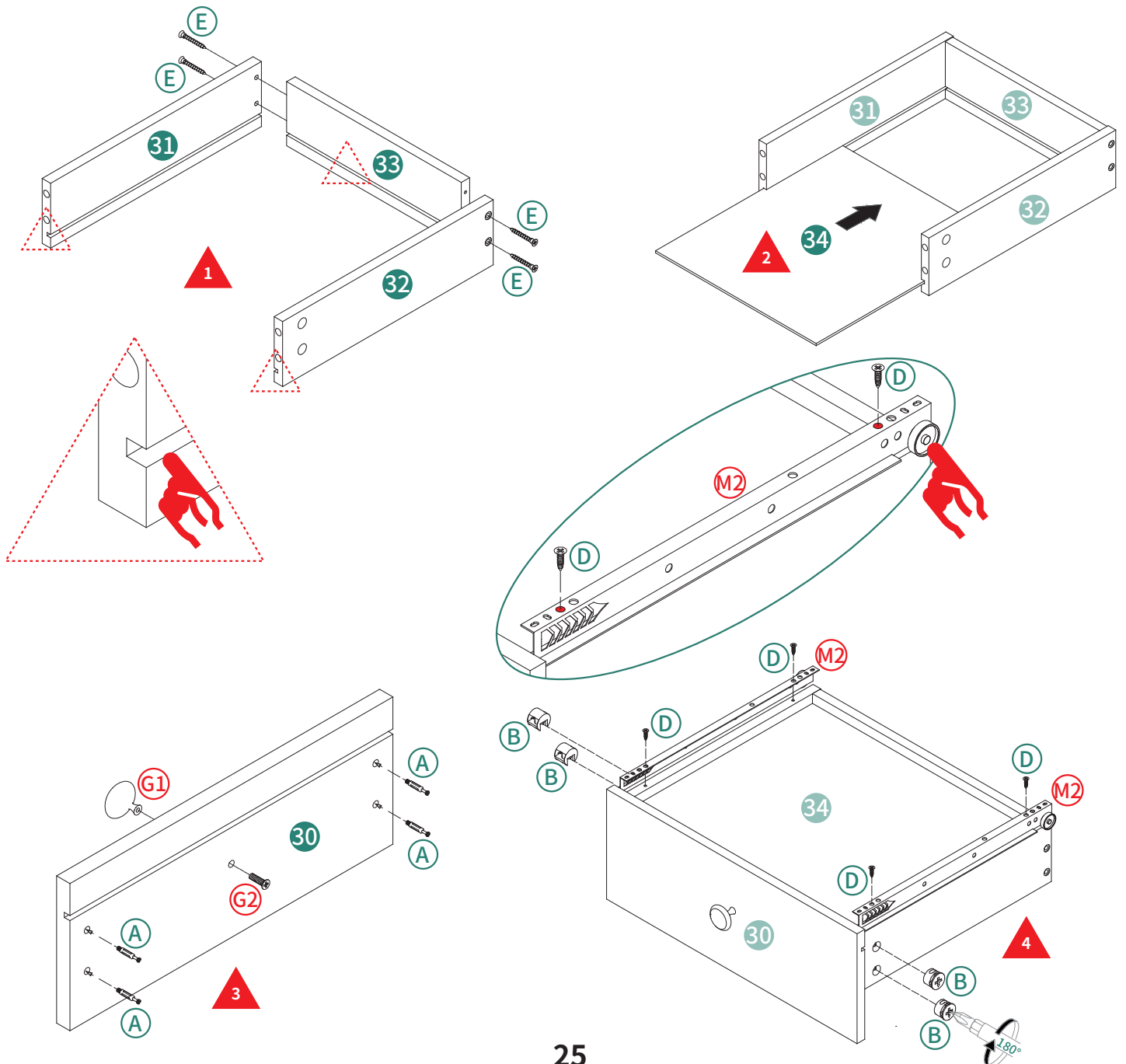

Note : Assurez-vous que les positions marquées par des triangles sont orientées dans la même direction.

Nota: Assicurati che le posizioni contrassegnate da triangoli siano rivolte nella stessa direzione.

Nota: Asegúrate de que las posiciones marcadas con triángulos estén orientadas en la misma dirección.

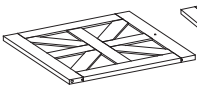
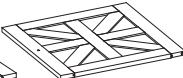
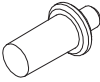

# 22

					
<b>M4*18mm</b>	<b>ST3*10mm</b>		<b>G1</b>	<b>G2</b>	<b>H3</b>
<b>H4</b>					
<b>14 1pc</b>	<b>15 1pc</b>	<b>F 4pcs</b>	<b>G 2pcs</b>	<b>H 2pcs</b>	

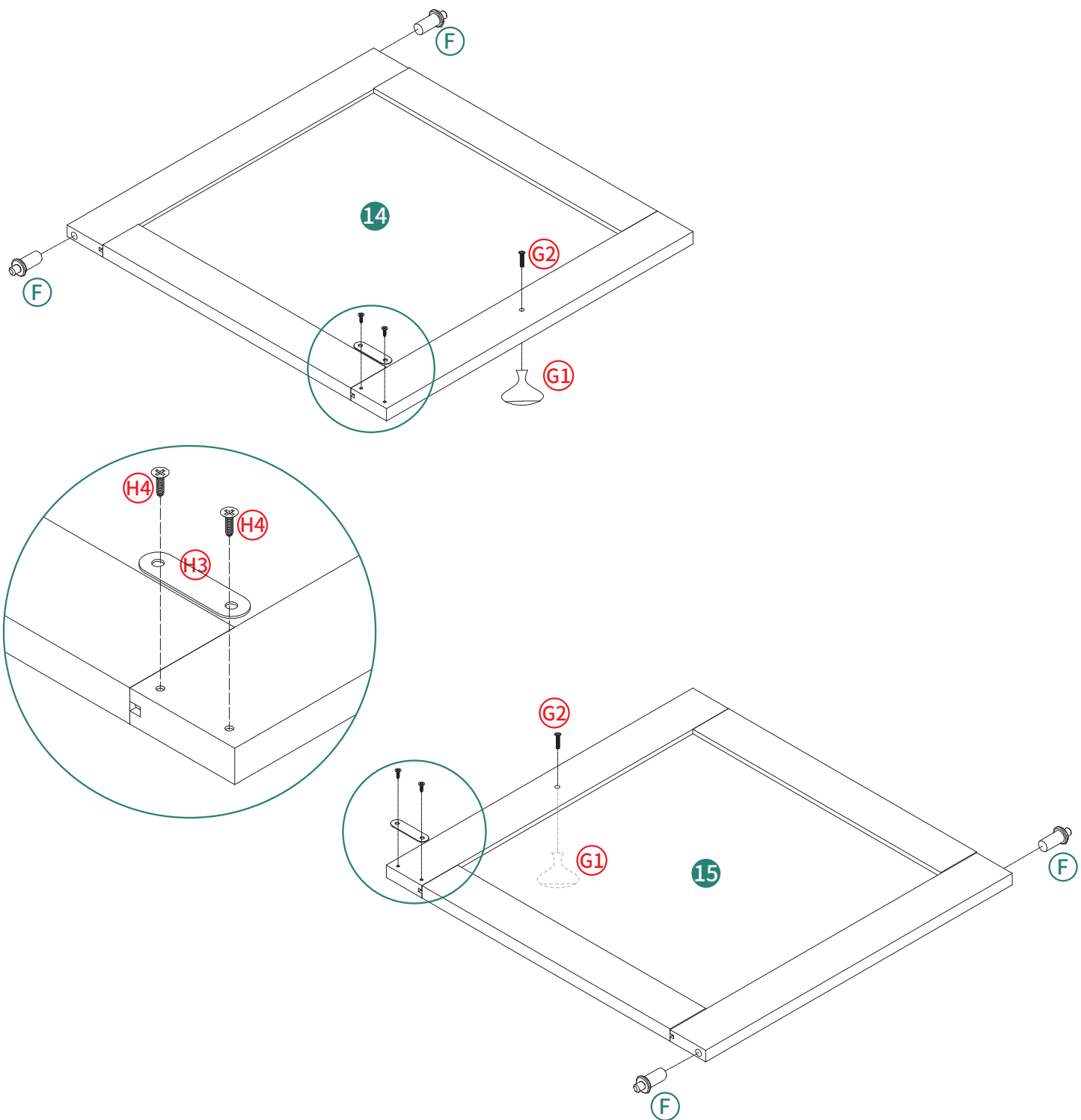

# 23

ST3.5\*14mm

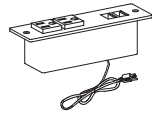

(D) 2pcs (N) 1pc

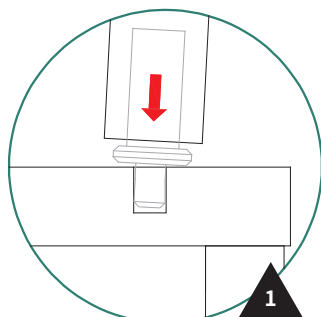
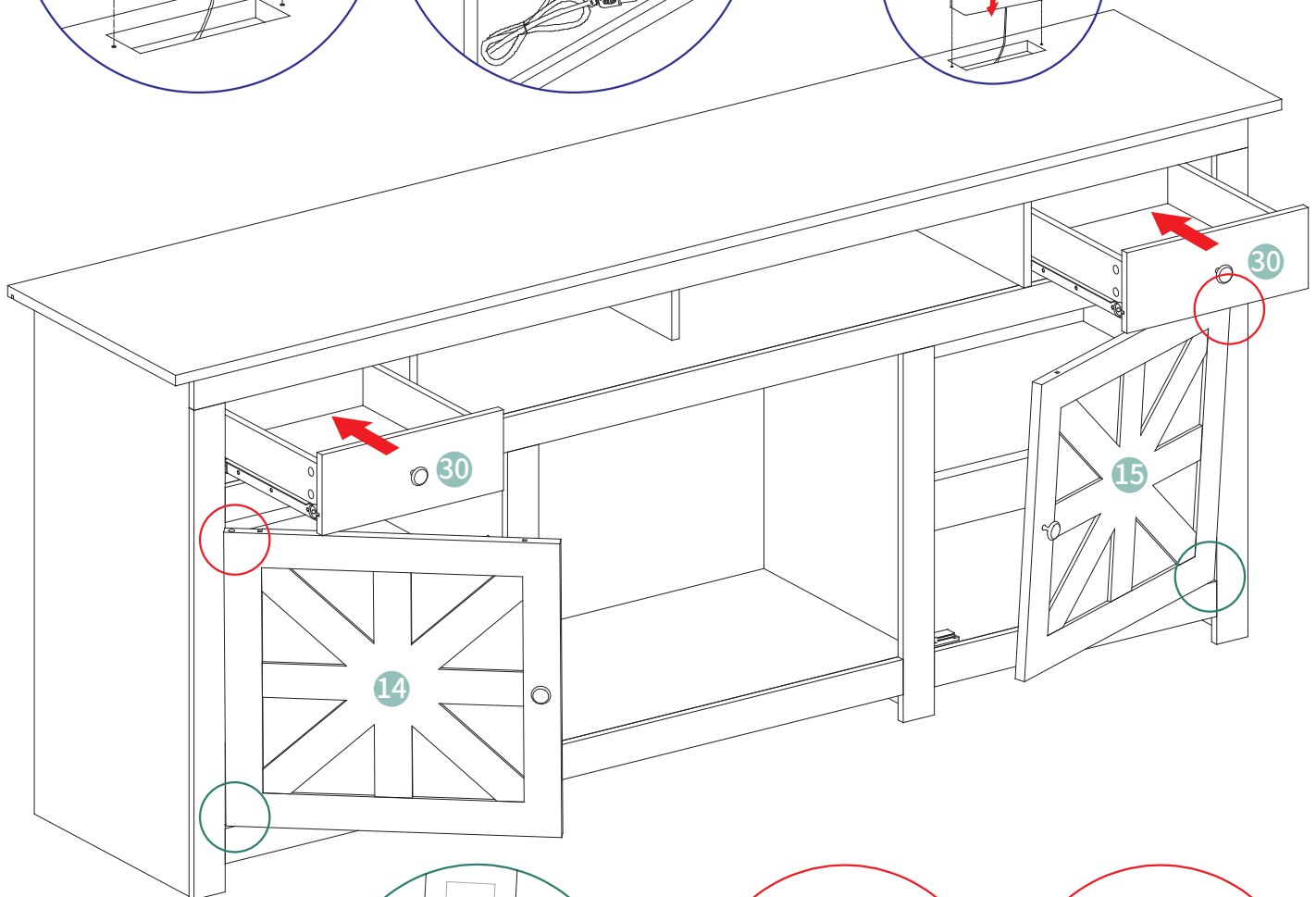
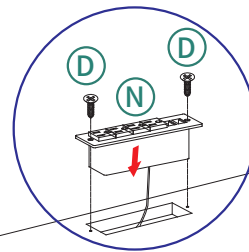
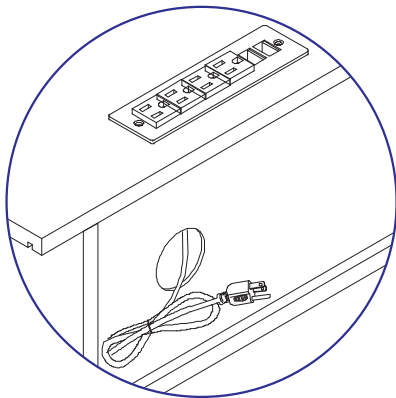
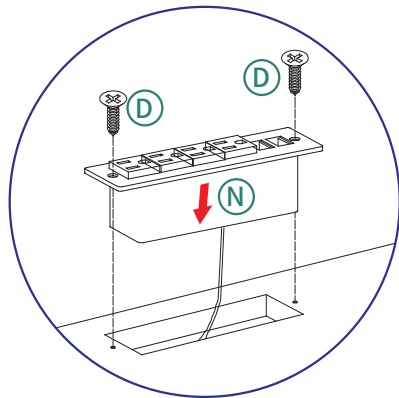

1

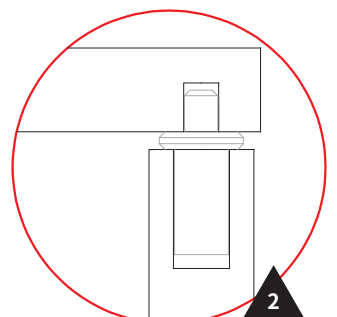
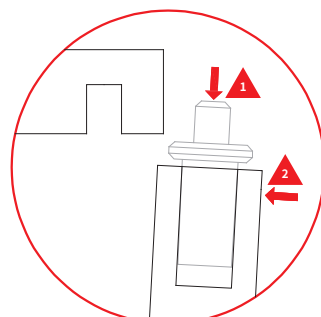

2

# 24

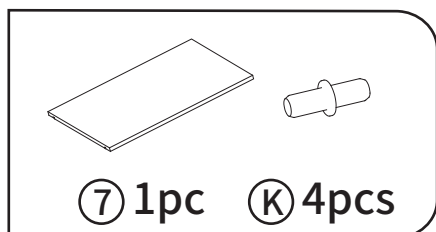

When installing the partition board (exclude step 25).

Bei der Installation der Trennwand (Schritt 25 ausgenommen).

Lors de l'installation de la cloison (à l'exception de l'étape 25).

Durante l'installazione del pannello divisorio (escludendo il passaggio 25).

Al instalar el tablero de partición (excluyendo el paso 25).

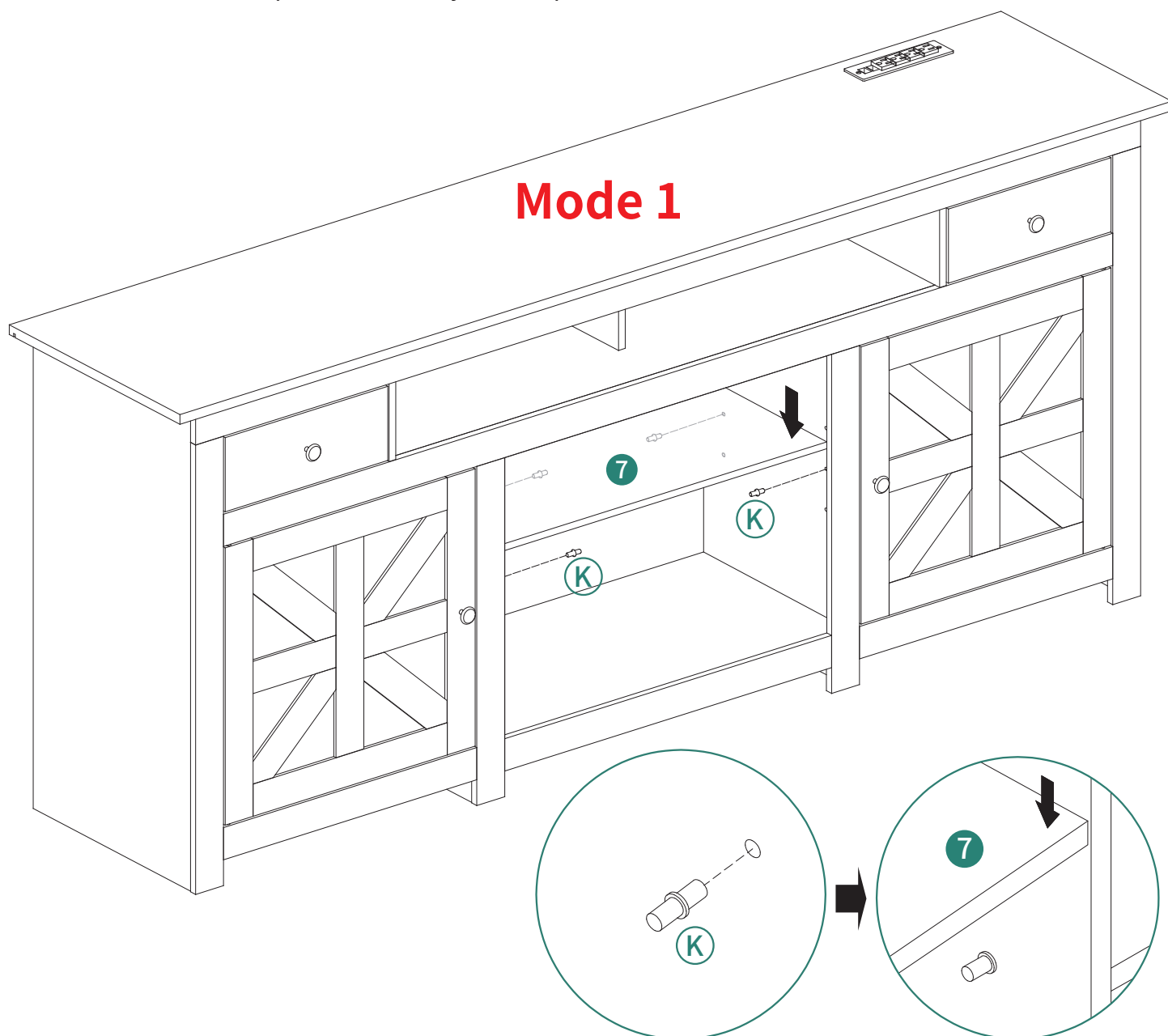

# 25

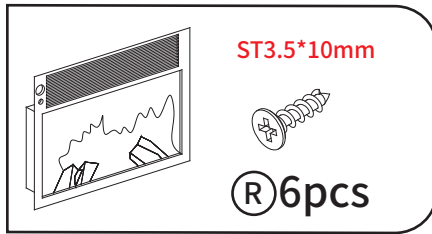

When installing the fireplace (exclude step 24).  
Bei der Installation des Kamins (Schritt 24 ausgenommen).  
Lors de l'installation de la cheminée (à l'exception de l'étape 24).  
Durante l'installazione del camino (escludendo il passaggio 24).  
Al instalar la chimenea (excluyendo el paso 24).

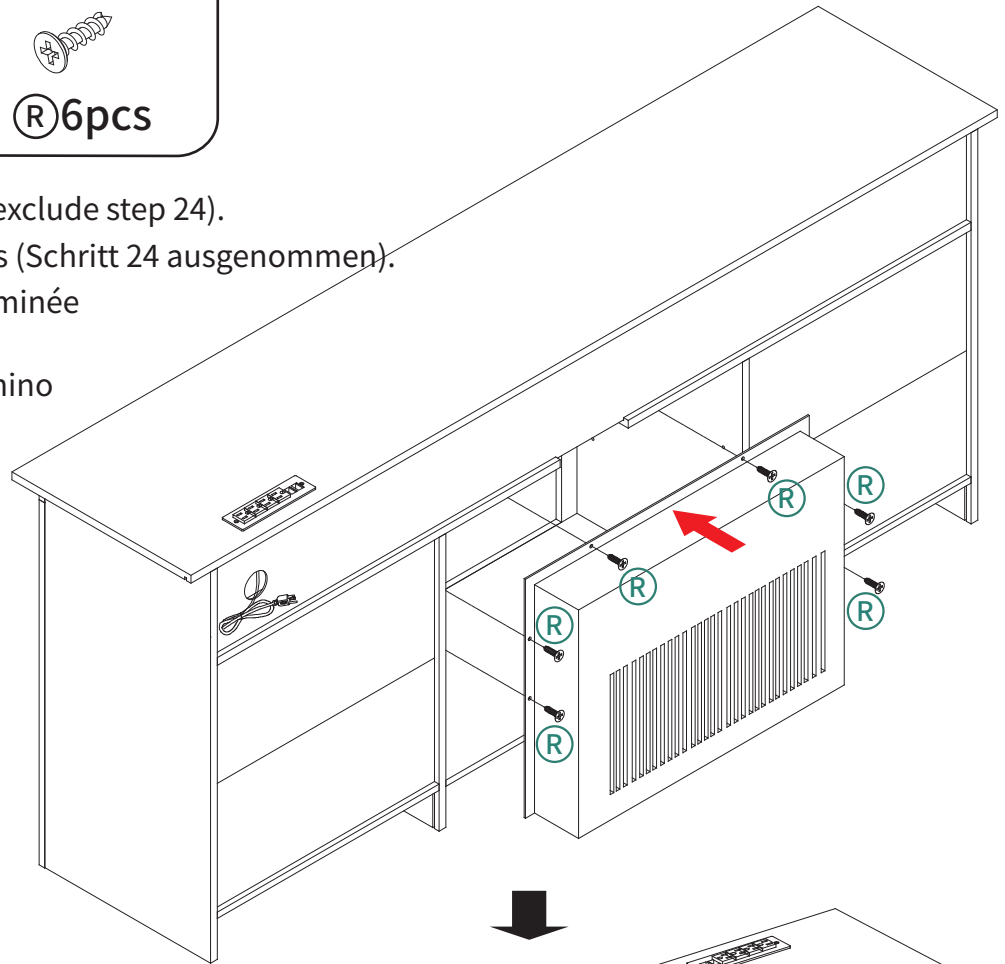

## Mode 2

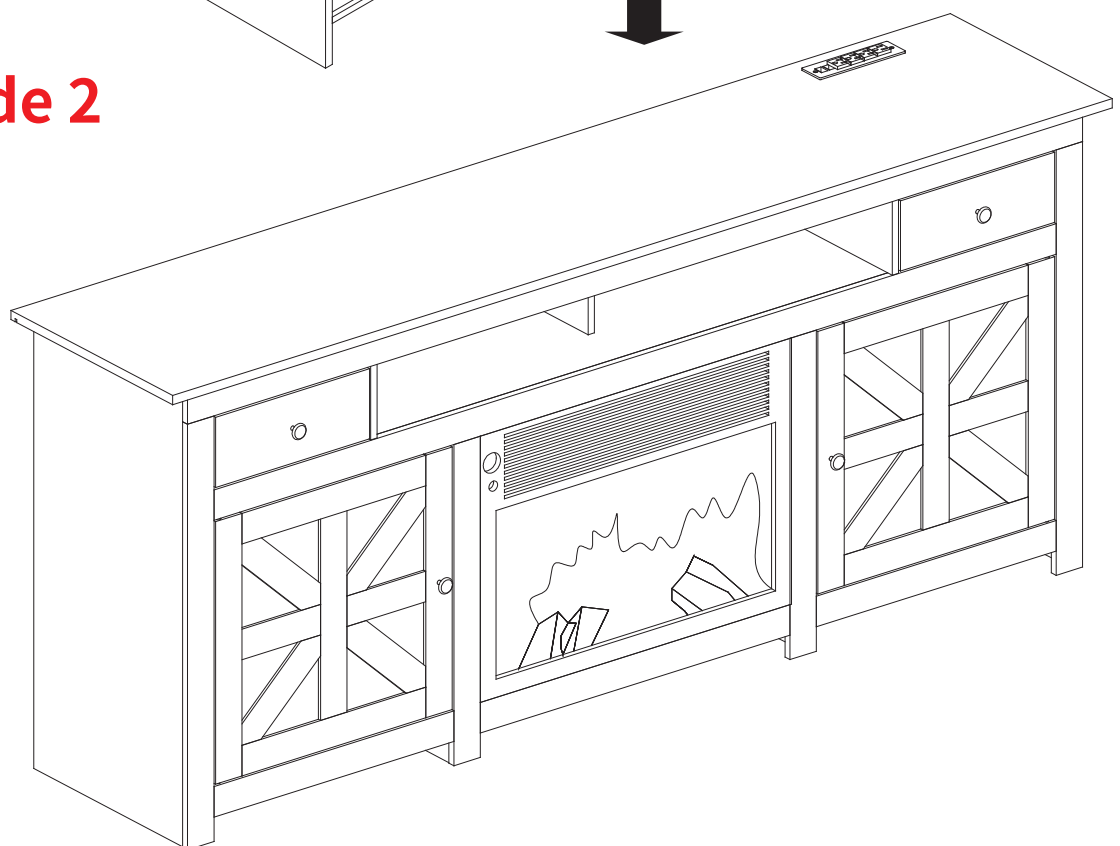

# 26

ST3.5\*14mm

ST3\*16mm



D 2pcs

I 14pcs

O 2pcs

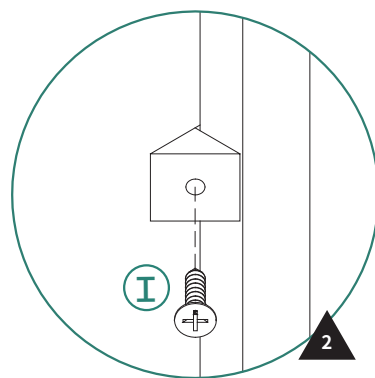
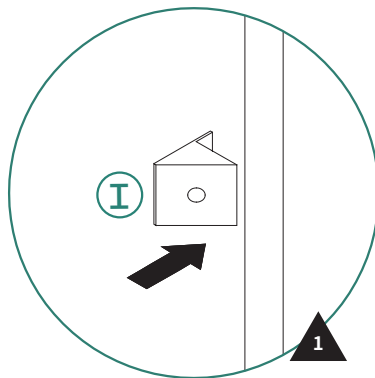
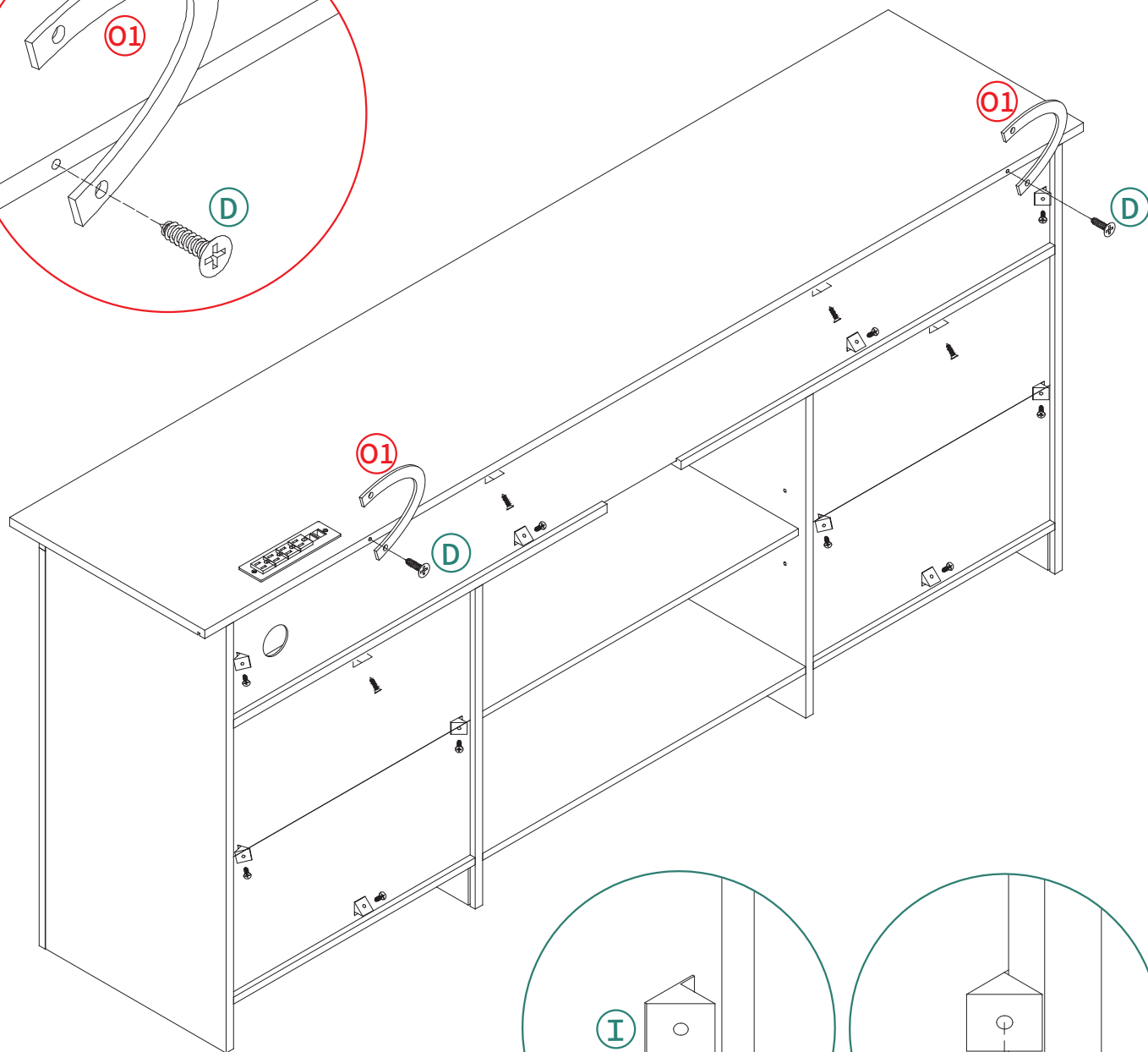
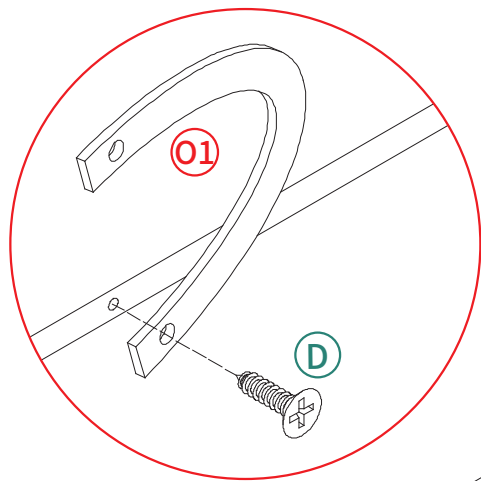

# 27

ST4\*38mm

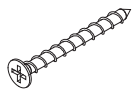

ⓔ 2pcs

ⓐ2



ⓐ 2pcs

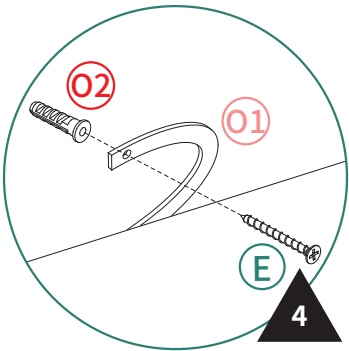
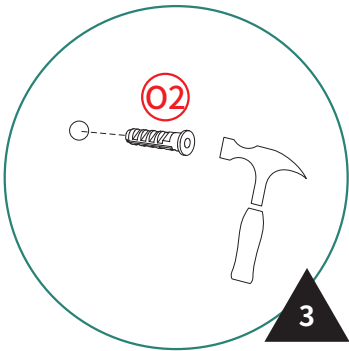
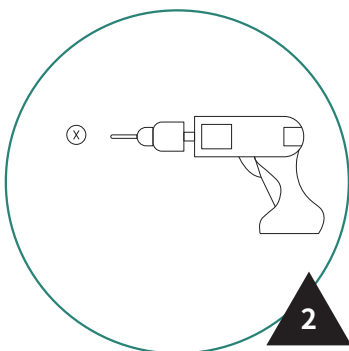
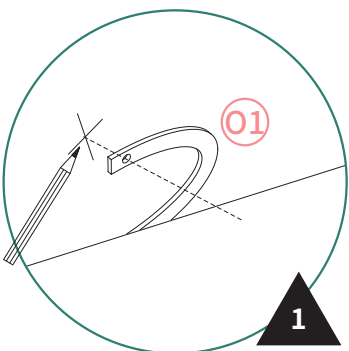
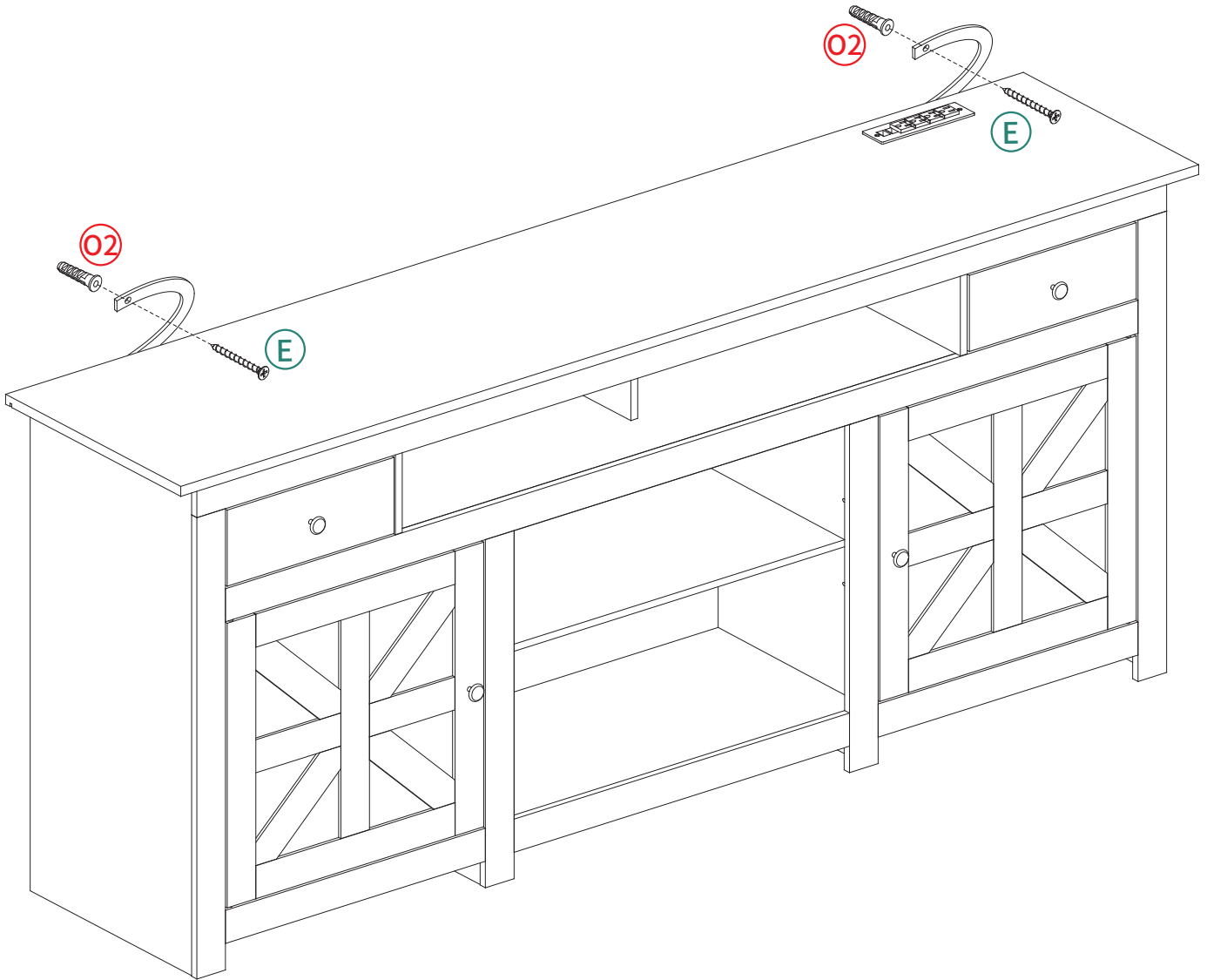

28

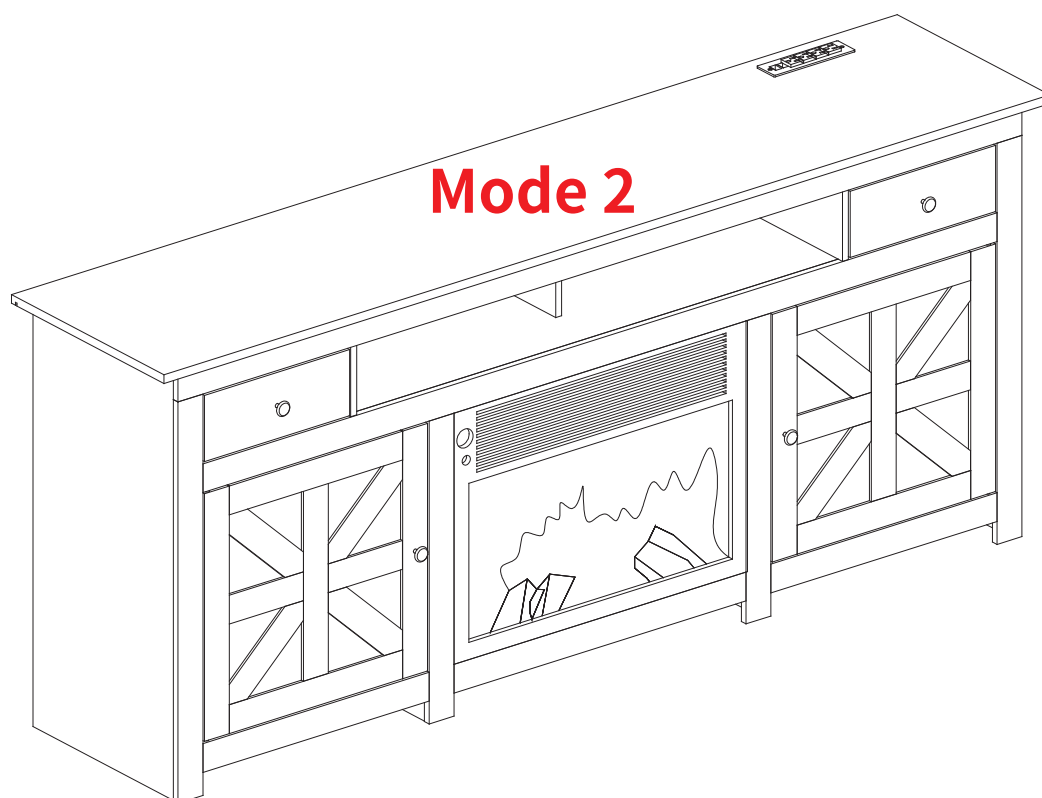
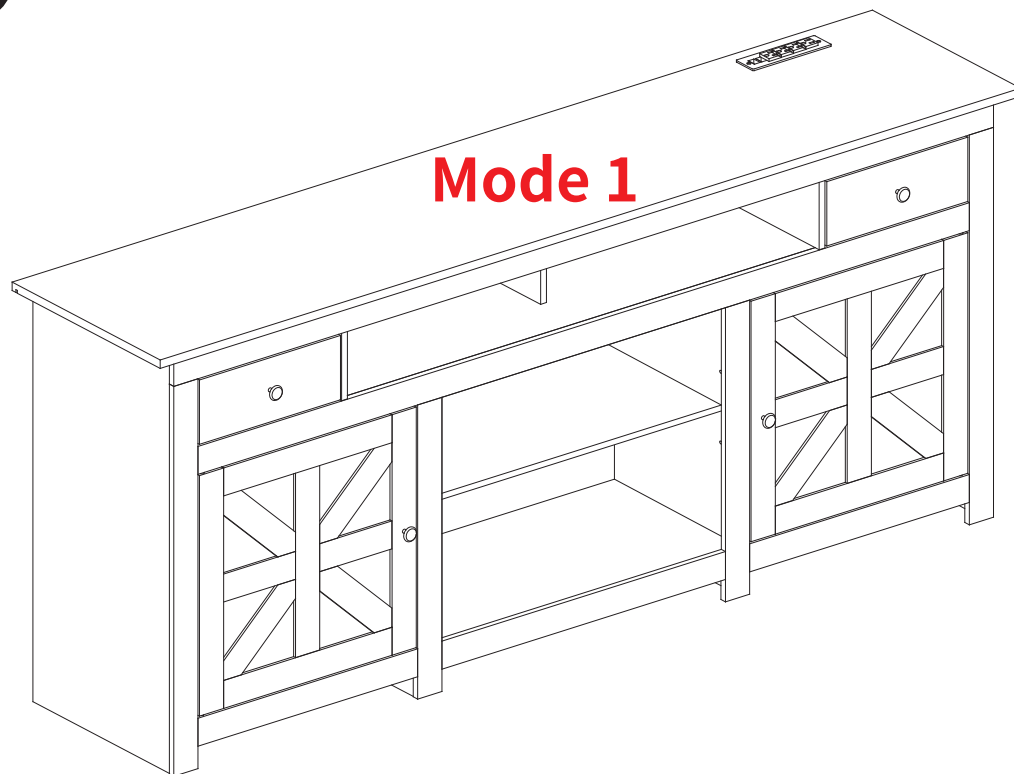

Installation Completed

Installation abgeschlossen

Installation complétée

Installazione completata

Instalación completada