





ASSEMBLY INSTRUCTION

Description: GLIDER RECLINER MANUAL

Thank you for purchasing this quality product. Be sure to check all packing material carefully for small parts that may have come loose inside the carton during shipment

PARTS LIST:

| NO. | DESCRIPTION | SKETCH | Q'TY |
|-----|-------------|---|------|
| A | Seat Body |  | 1 PC |
| B | Backrest |  | 1 PC |
| C | Left wing |  | 1 PC |
| D | Right wing |  | 1 PC |

Step 1:

Important:

1. Attach Backrest (B) to the Seat (A).
2. Attach the Left/Right Wings (C/D) to the Left/Right side of the Backrest (B).

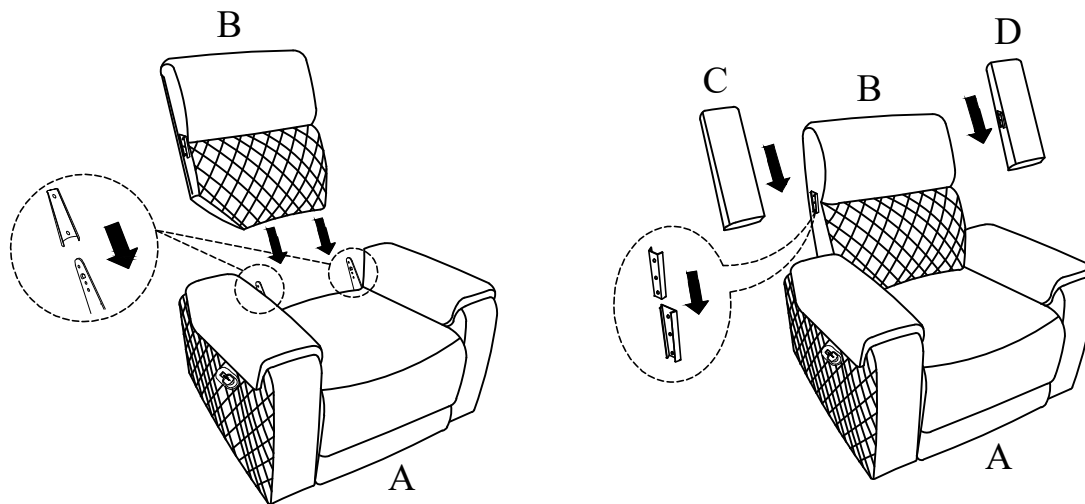

Step 2:

Important: Open the Footrest by pulling out the Switch.

