

Kitchen Cart

IMPORTANT NOTE

Carefully remove all the parts from the carton and put them individually on a soft cloth to prevent scratches or other damages occurring to the parts.

We have taken great care in the design of this product and request that you carefully and strictly follow our assembly instructions to ensure a completed product as it was designed.



PART LIST

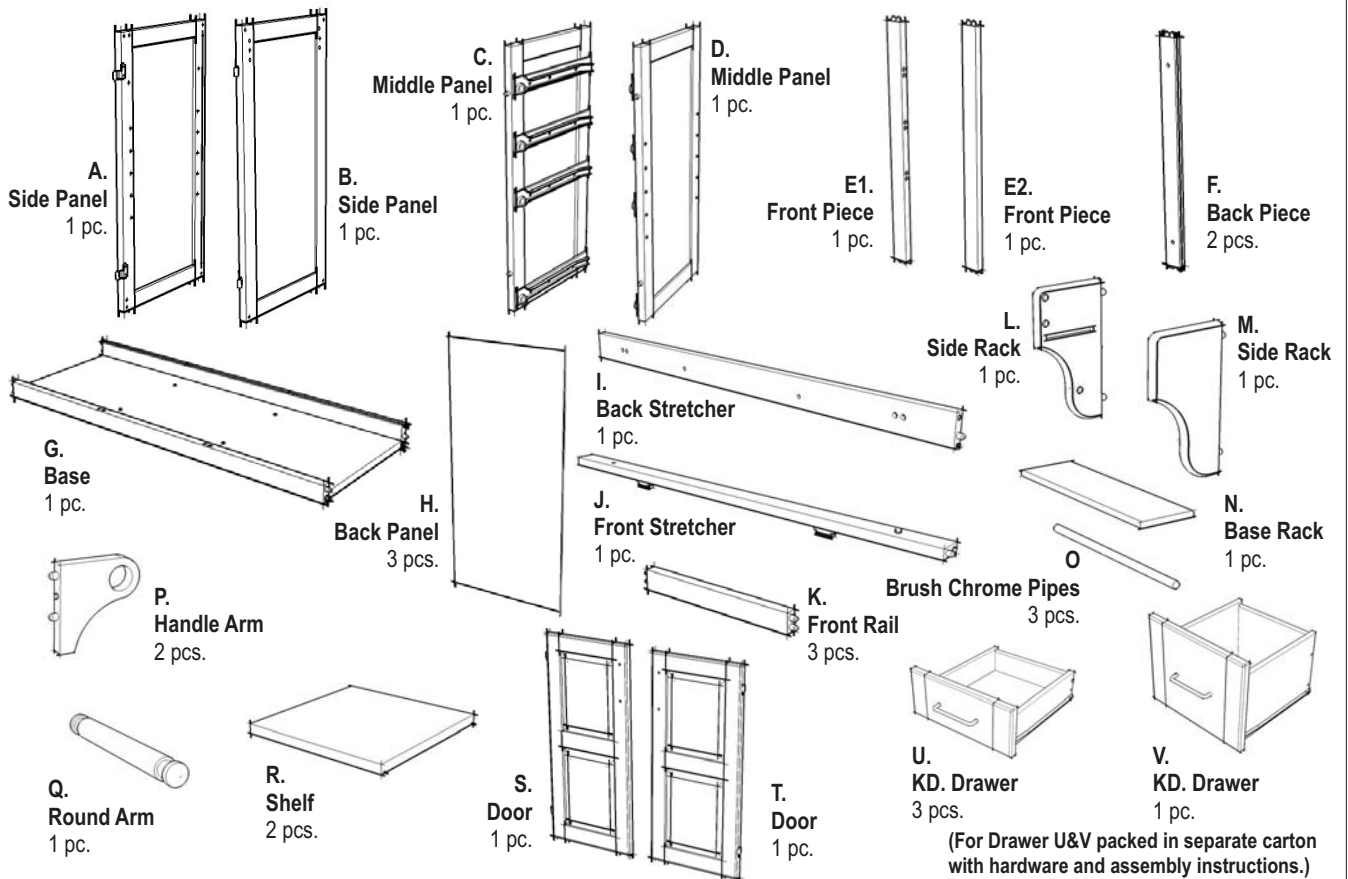

HARDWARE LIST



Tools Required For Assembly : Phillips screwdriver

IMPORTANT

Do not tighten up all the screws until each part is properly assembled. You should keep Hex Wrench in the safe place as you may need to tighten up the Head Cap Bolts in the future.

STEP 1

Attach four Casters underneath Base (G) with Wood Screws. (See 'Arrow' sticker indicating front side)

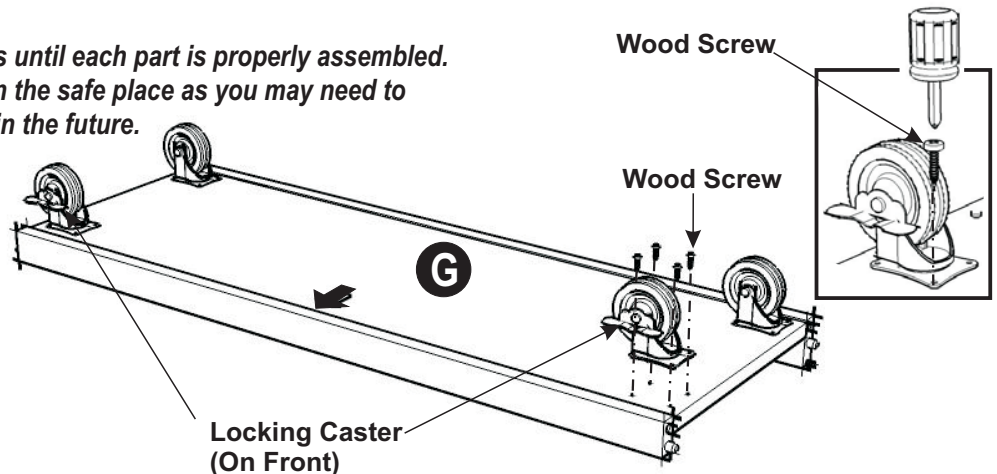

STEP 2

Attach the Back Piece (F), Middle Panel (C) and Back Piece (F), Middle Panel (D) onto the Base (G).

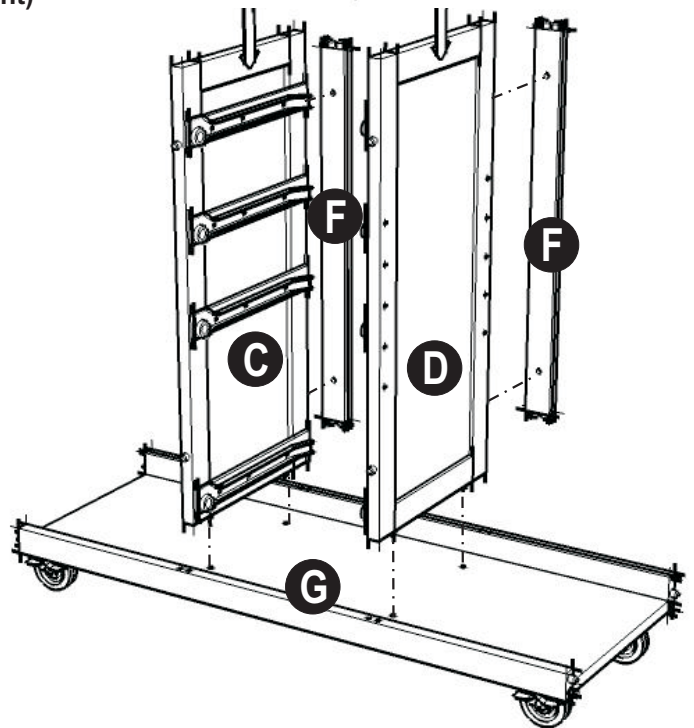
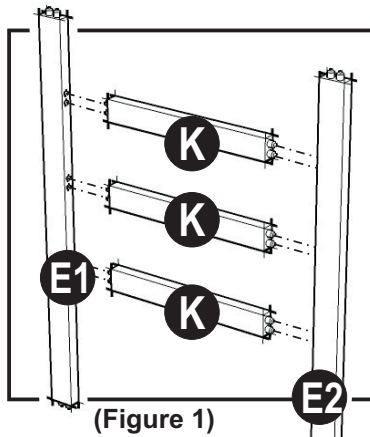

STEP 3

Assemble Front Piece (E1), (E2) and Front Rail (K). (See figure 1)

Attach the assembled unit to Middle Panel (C) and (D).

Attach Side Panel (A) to the side of unit with Head Cap Bolts.

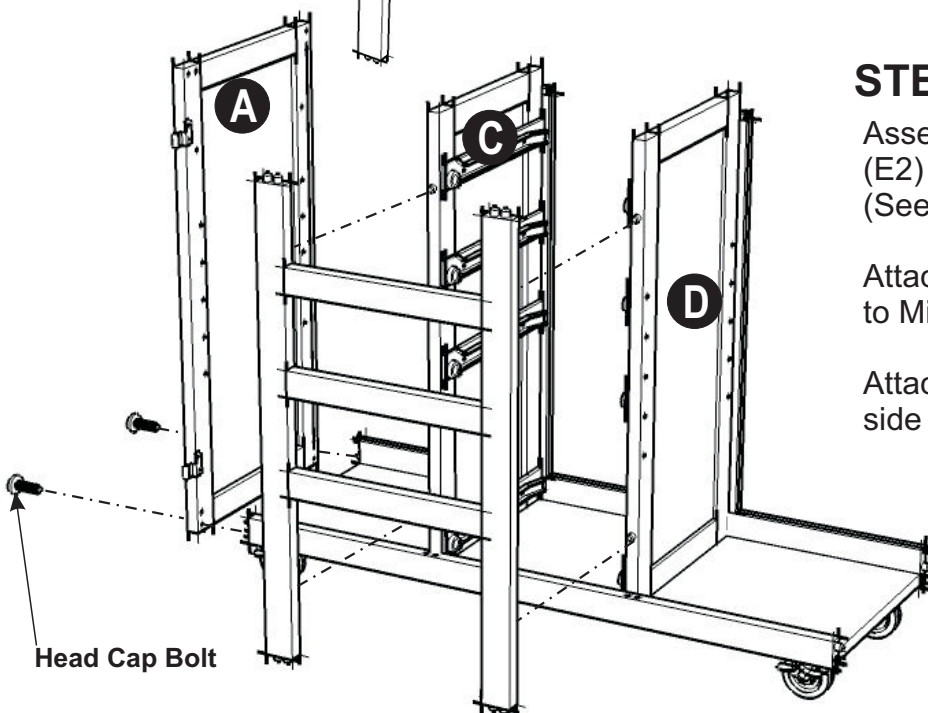

STEP 4

Slide Back Panel (H) into place.

Attach Back and Front Stretcher (I), (J) to the unit with Head Cap Bolts.

Attach Side Panel (B) to the other side of unit with Head Cap Bolts.

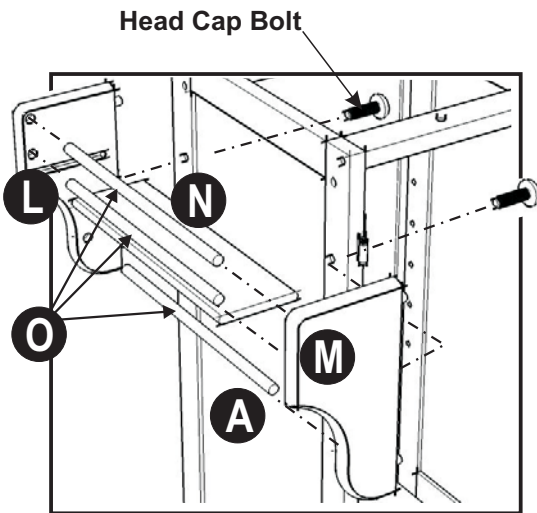
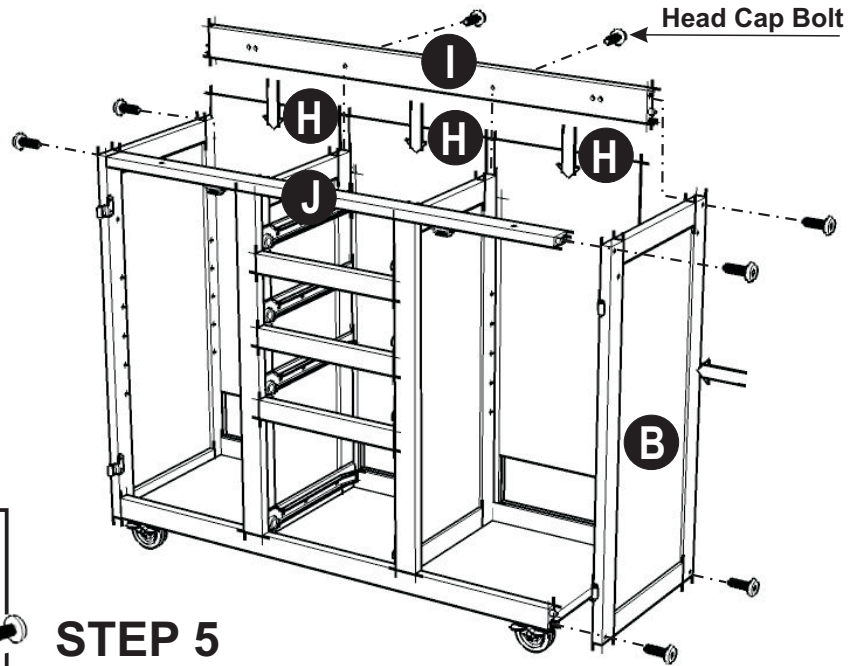

STEP 5

Attach Side Rack (L) to Side Panel (A) with Head Cap Bolts.

Attach Brush Chrome Pipes (O) and Base Rack (N) to the Side Rack (L).

Attach Side Rack (M) to the Side Panel (A), using Head Cap Bolts.

STEP 6

Attach Handle Arm (P) to Side Panel (B) with Head Cap Bolts.

Slide the Round Arm (Q) into place.

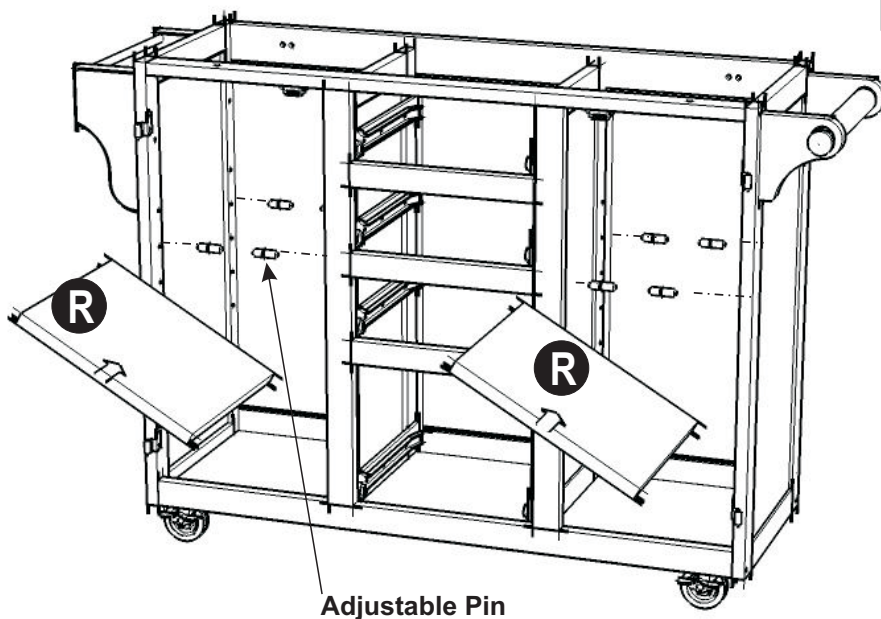
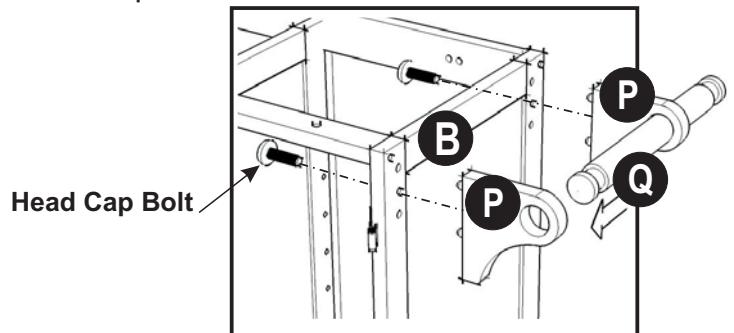

STEP 7

Insert Adjustable Pins into both side panels and middle panels at the desired level. Place Shelf (R).

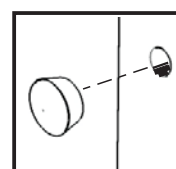

STEP 8

Cover up all holes with Wood Plugs.

Drawer (U)

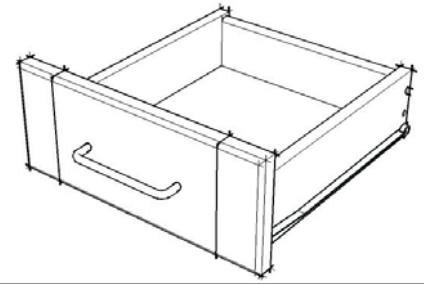

UNIT PART LIST

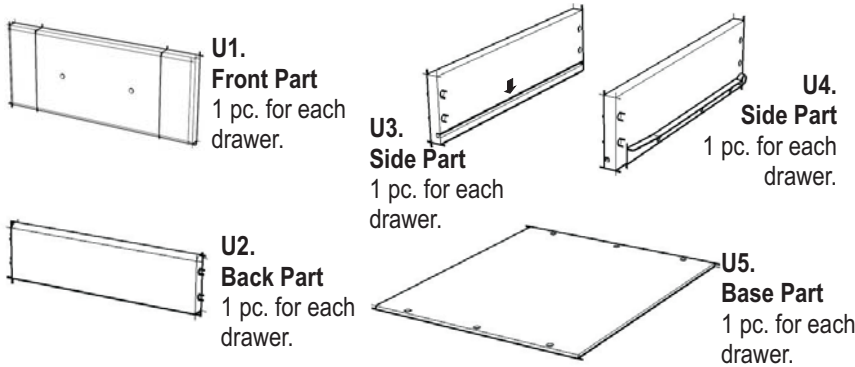

HARDWARE LIST

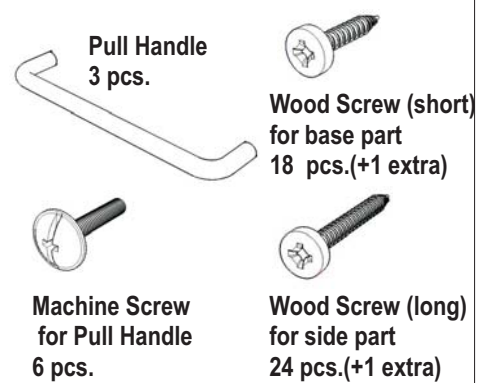

Assembly Instructions

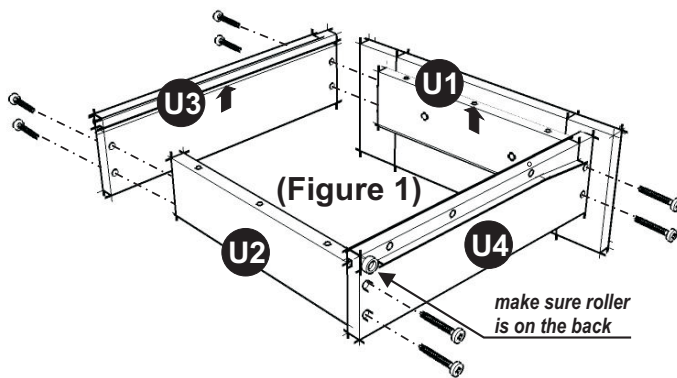

Using a philips screwdriver, insert 1" screws into the pre-drilled holes as shown, tighten half way. (See the figure 1)

Slide the Plywood Base Part (U5) into the grooves on Side Parts (U3) and (U4). Be sure to push the plywood all the way forward so it meets the Front Part (U1). (See the figure 2)

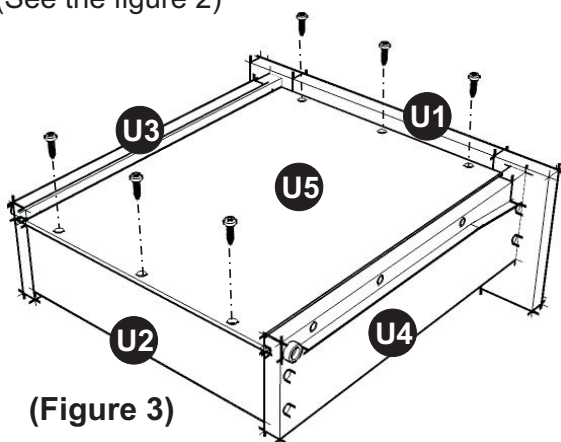
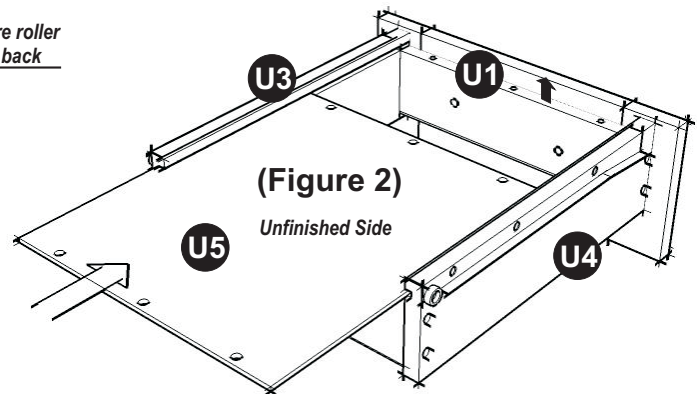

Insert the remaining (6) 1/2 screws into the pre-drilled holes on Base Part (U5), then tighten all screws.

Assemble the Pull Handle with Machine Screw on the Front Part (U1).

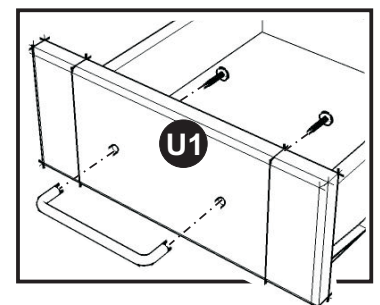

Drawer (V)

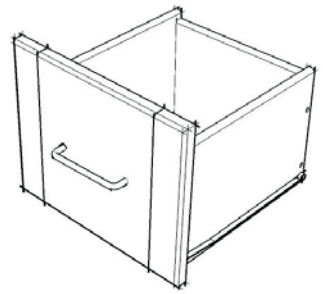

UNIT PART LIST

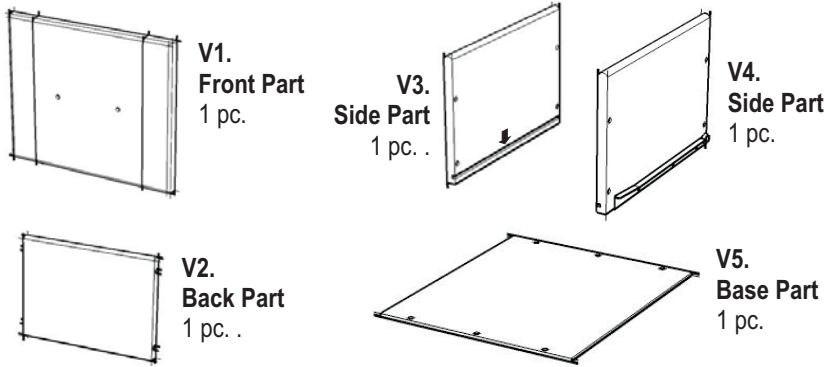

HARDWARE LIST

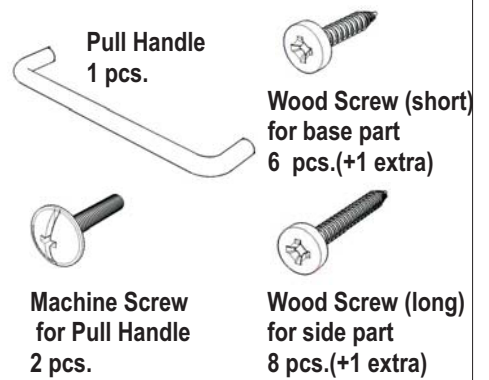

Assembly Instructions

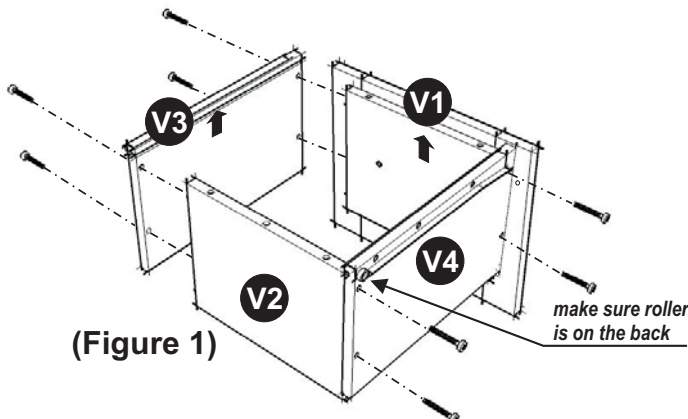

(Figure 1)

Using a philips screwdriver, insert 1" screws into the pre-drilled holes as shown, tighten half way. (See the figure 1)

Slide the Plywood Base Part (V5) into the grooves on Side Parts (V3) and (V4). Be sure to push the plywood all the way forward so it meets the Front Part (V1). (See the figure 2)

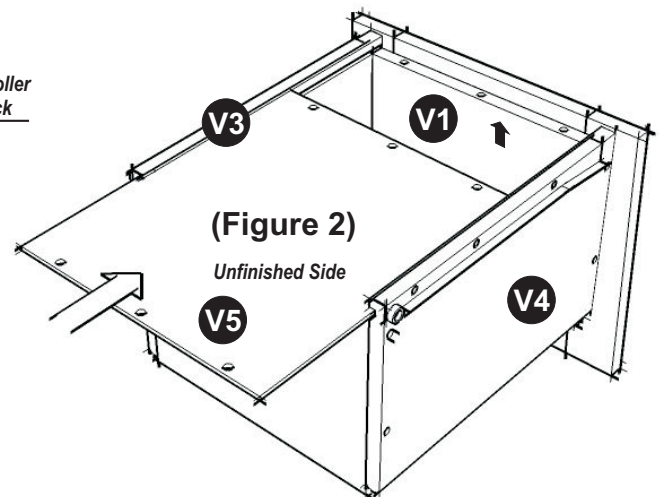

(Figure 2)

Unfinished Side

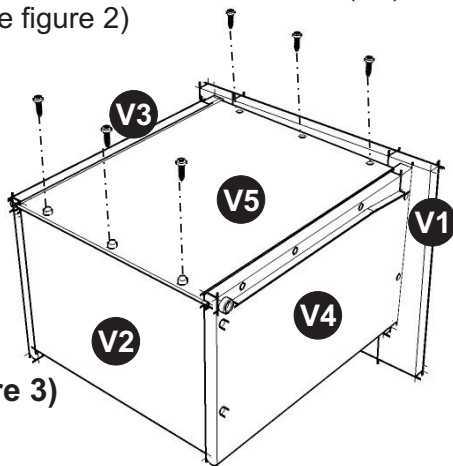

(Figure 3)

Insert the remaining (6) 1/2 screws into the pre-drilled holes on Base Part (V5), then tighten all screws (See the figure 3)

Assemble the Pull Handle with Machine Screw on the Front Part (V1). (See the figure 4)

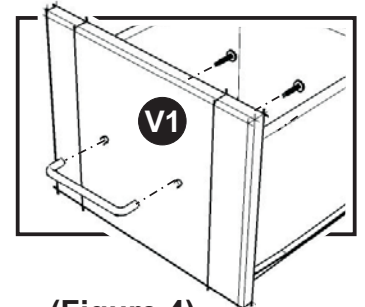

(Figure 4)