

Panel Bed-F/Q
Assembly Instructions

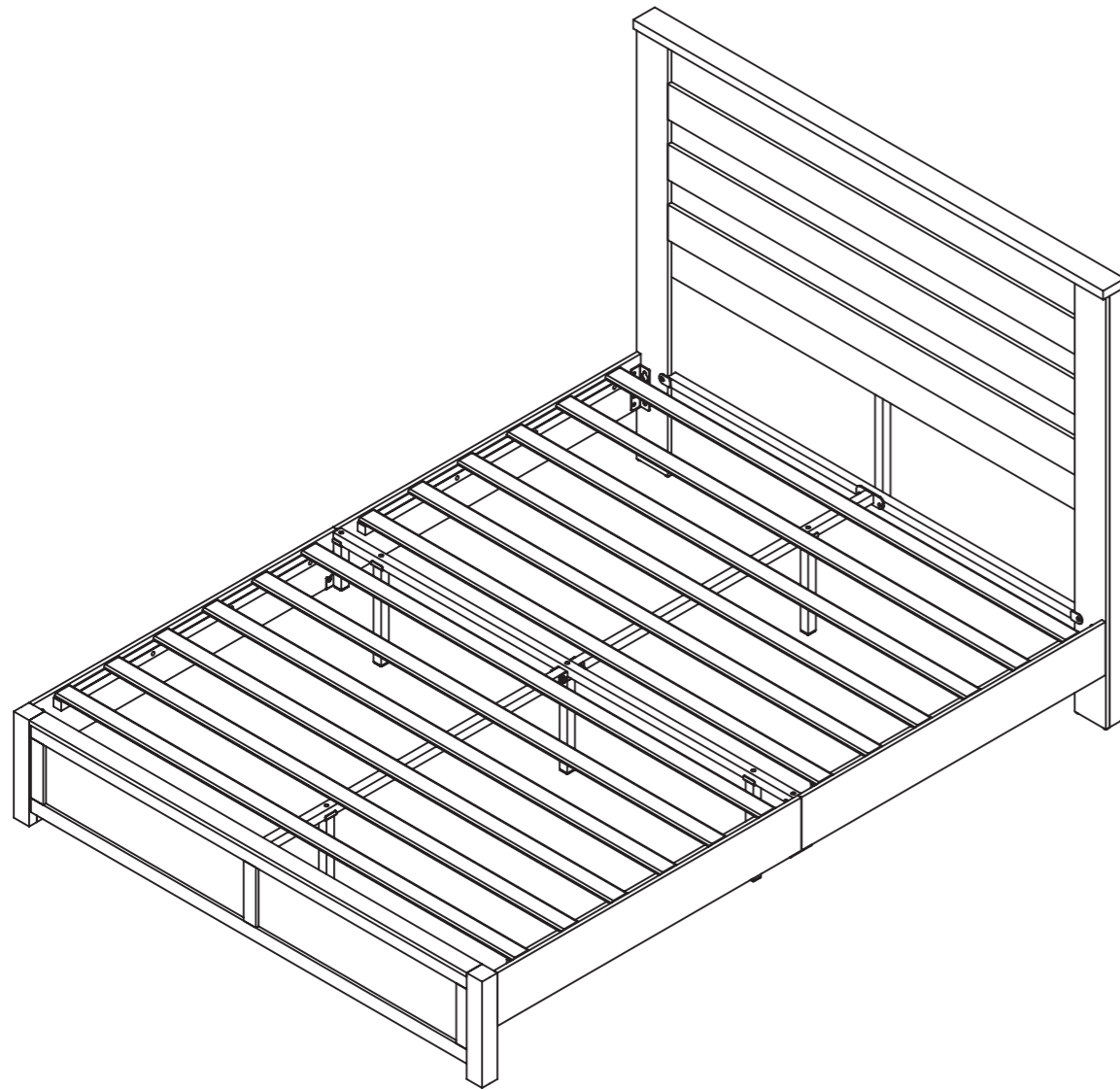

Dear Customers,

Thank you for purchasing our product. Please read this instruction manual carefully after receiving this product. It will help you assemble this product quickly, safely and correctly. You can keep this manual for future reference.

MADE IN CHINA



Please follow the instruction manuals and use a pad to protect the product during your assembly.

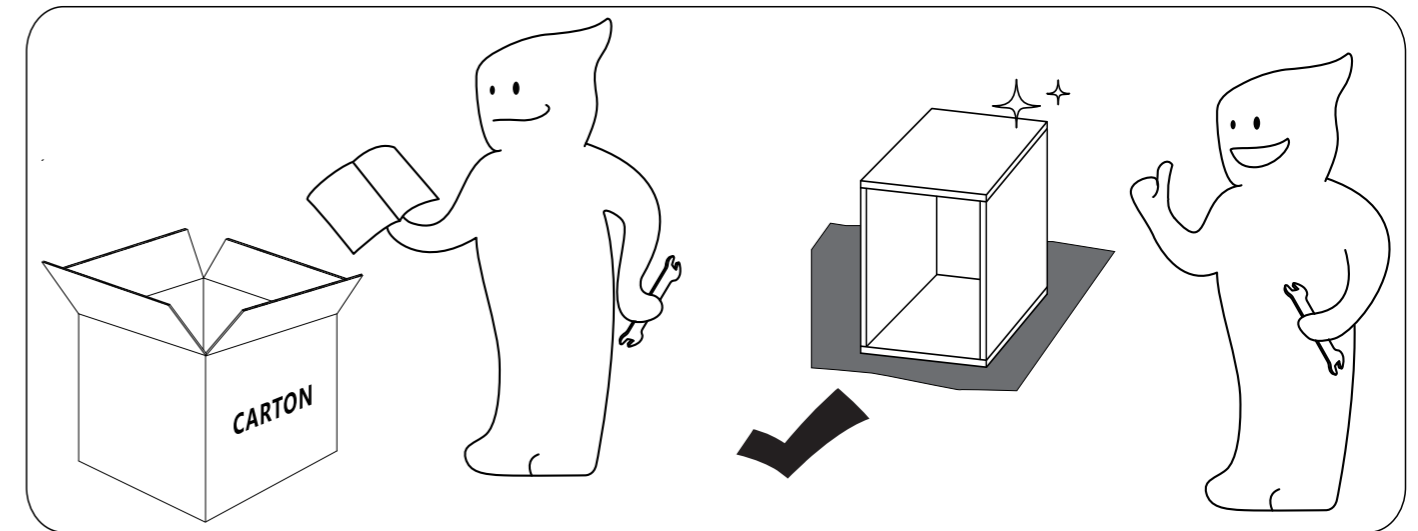
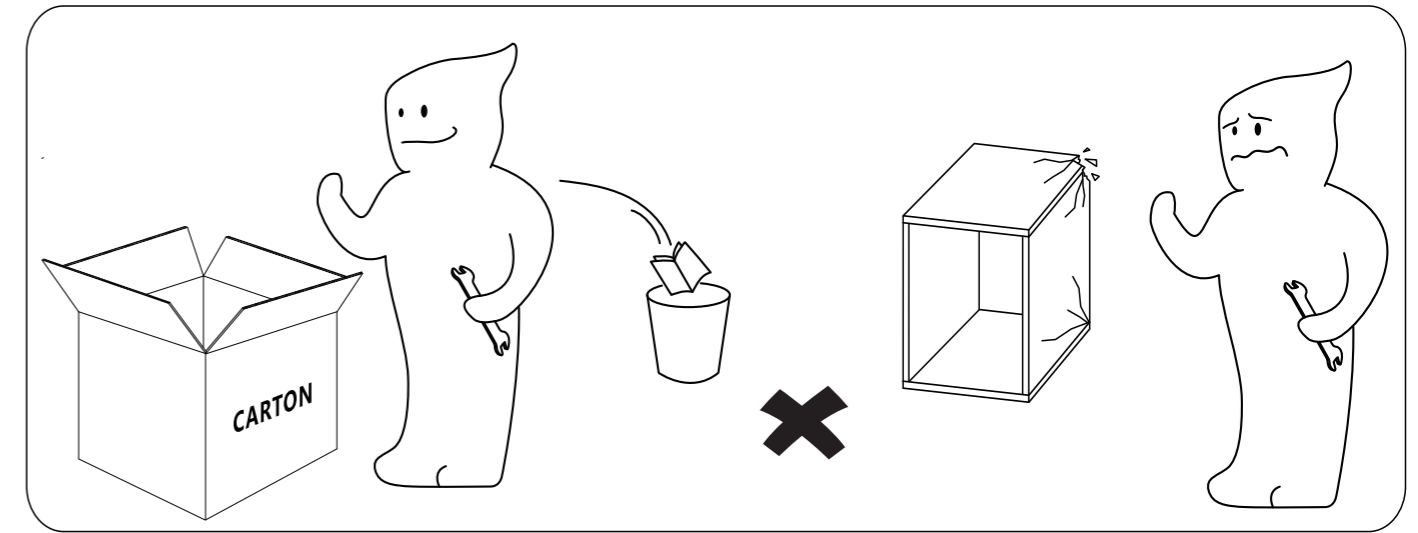



Note:

1. Should be assembled on flat ground to keep balance.
2. Before completing the installation, do not tighten the screws.

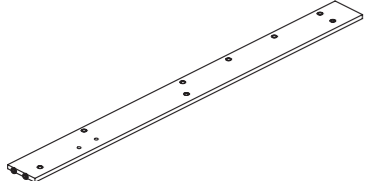
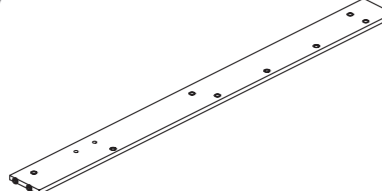
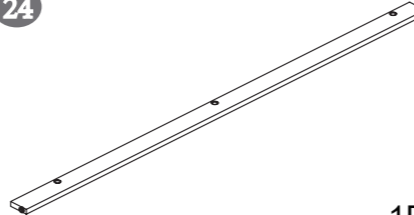
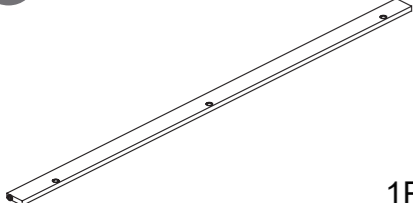
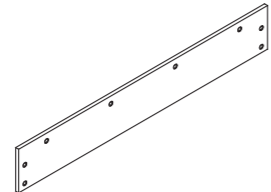
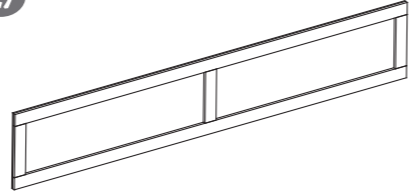
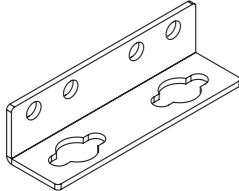

For easier and better assembly, **2** or more adults are required.

ASSEMBLY INSTRUCTIONS

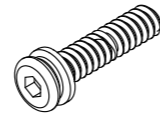
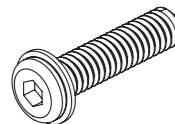
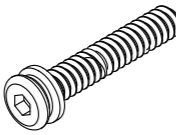
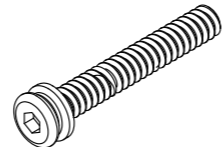
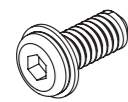
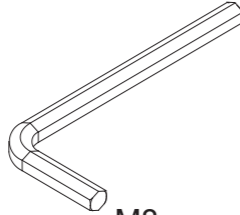
 <p>22 1PC</p>	 <p>23 1PC</p>	 <p>24 1PC</p>
 <p>25 1PC</p>	 <p>26 4PCS</p>	 <p>27 1PC</p>
 <p>L 4PCS</p>		
 <p>A M8*12 42PCS</p>	 <p>B M8*20 36PCS</p>	 <p>C M8*30 6PCS</p>
 <p>D M8*35 Color Zinc 24PCS</p>	 <p>E M8*40 10PCS</p>	 <p>F M8*50 8PCS</p>
 <p>G M8*18 Color Zinc 4PCS</p>	 <p>H M8 1PC</p>	

ASSEMBLY INSTRUCTIONS

Note: Before assembly, identify the part numbers and assemble them at the aligned hole positions

1

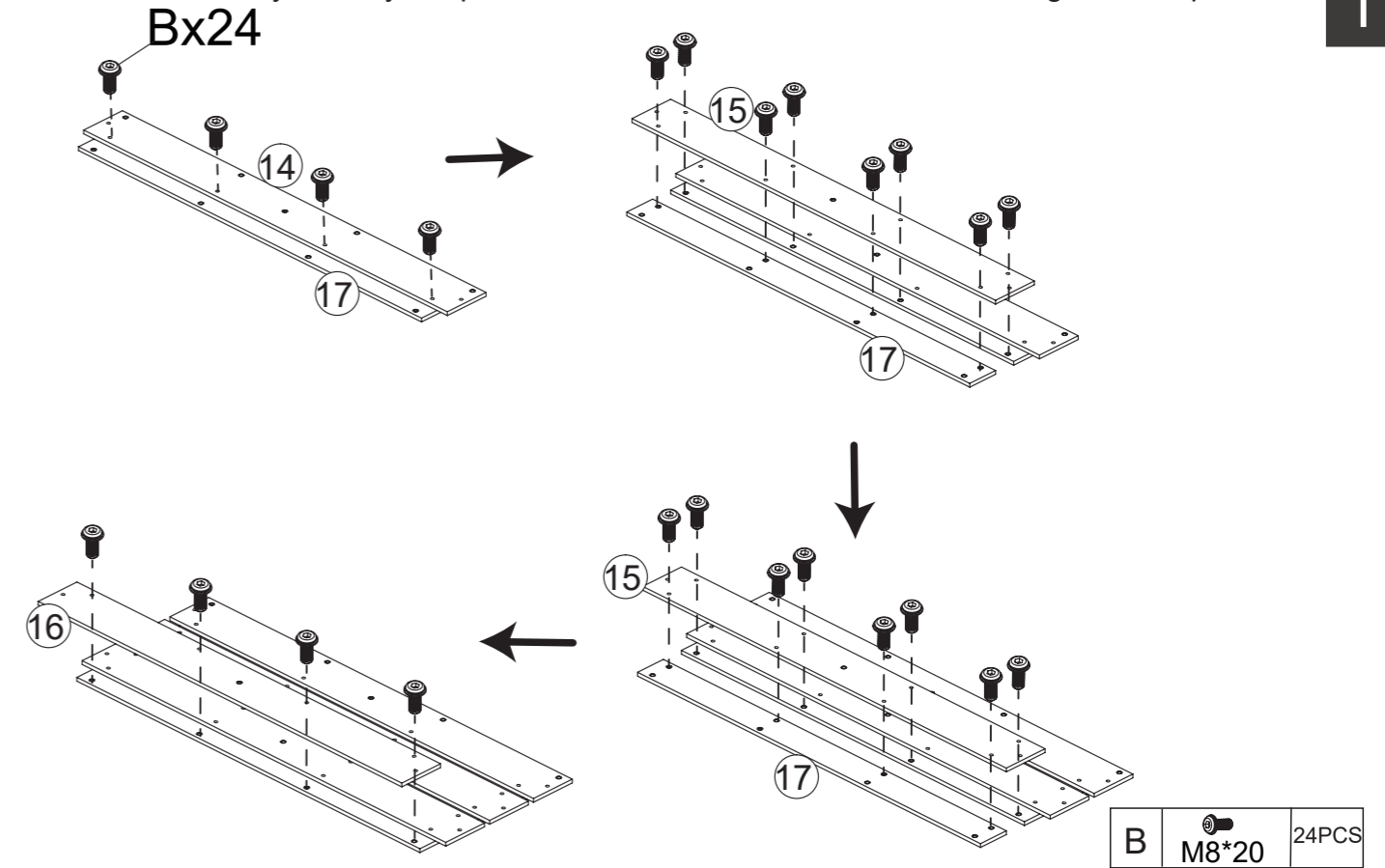

2

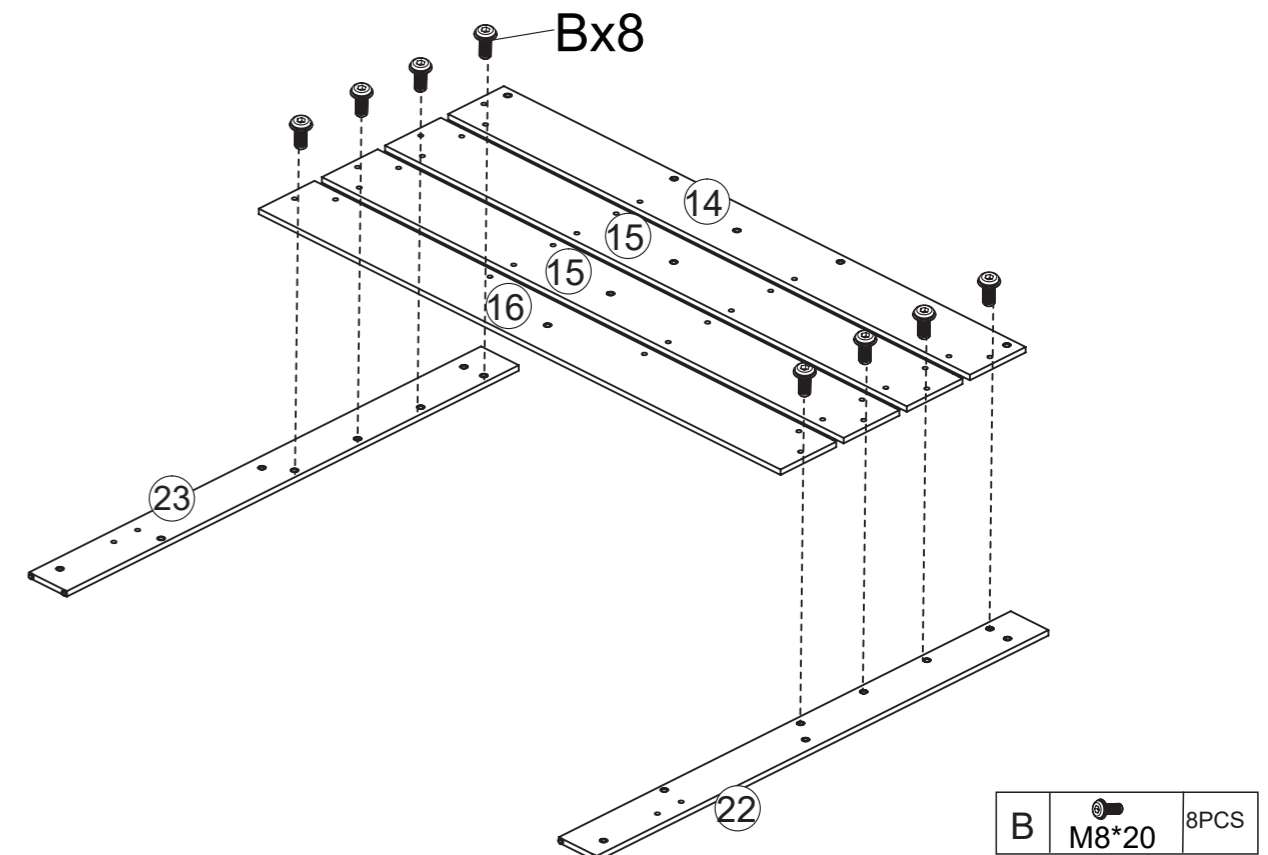

ASSEMBLY INSTRUCTIONS

3

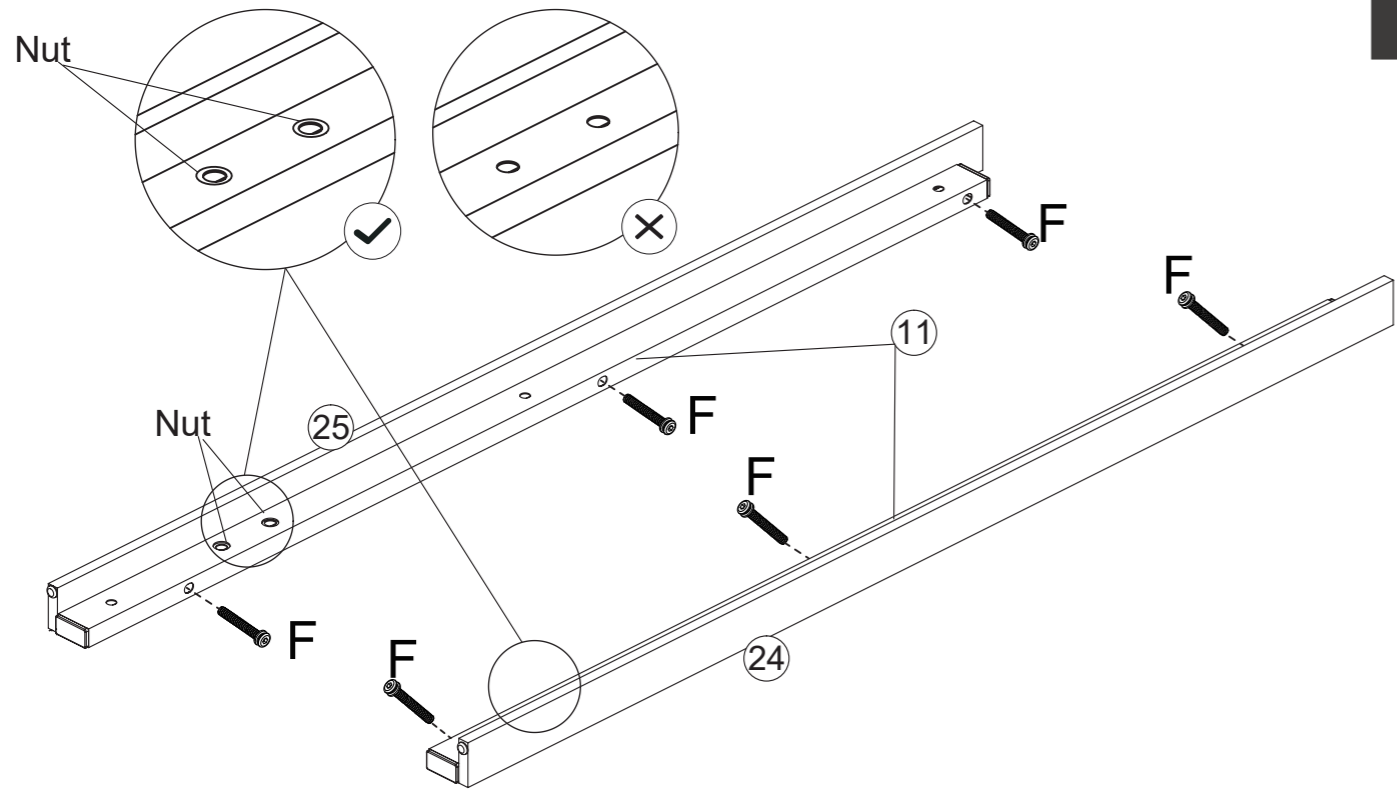

Note: Assemble with the nut facing upwards

F		M8*50	6PCS
---	--------------------------------------------------------------------------------------	-------	------

ASSEMBLY INSTRUCTIONS

5

Note: Lift the wooden board to prepare for assembly

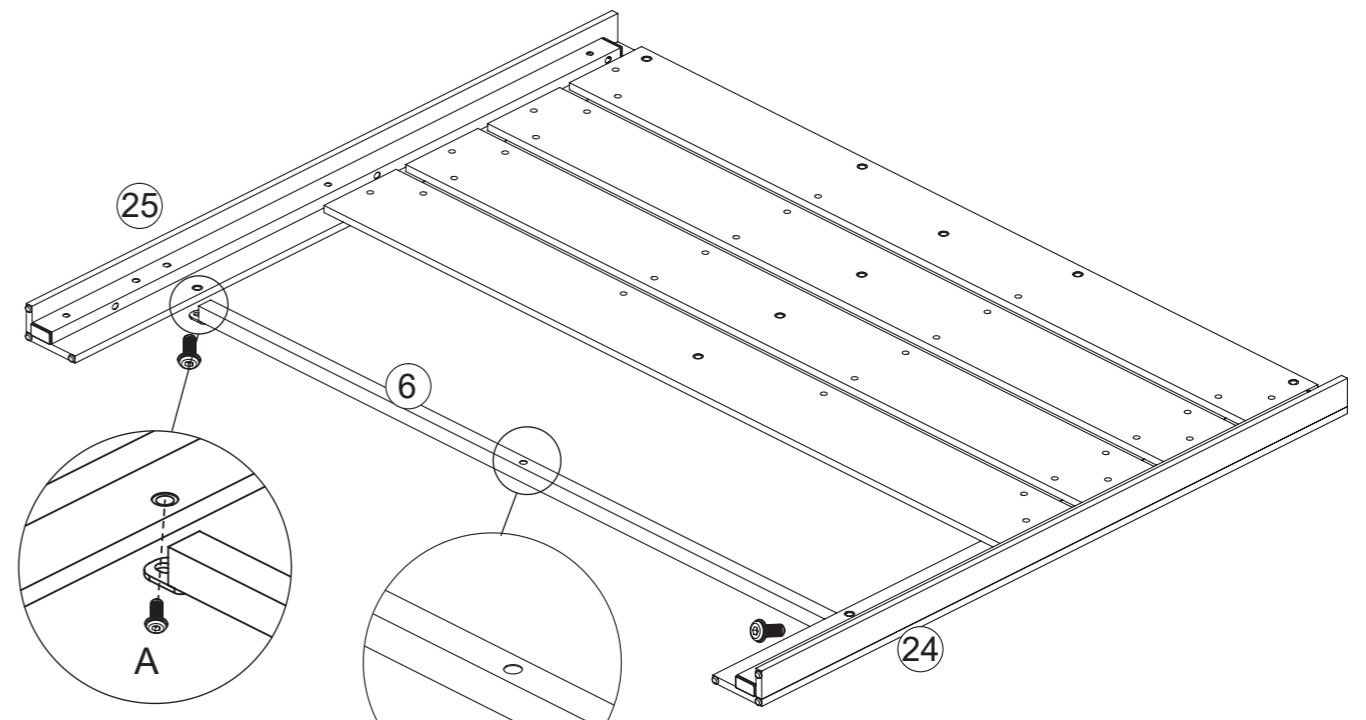

In this installation step, please ensure that the hole in the middle of component 6 is facing upward

A		M8*12	2PCS
---	--------------------------------------------------------------------------------------	-------	------

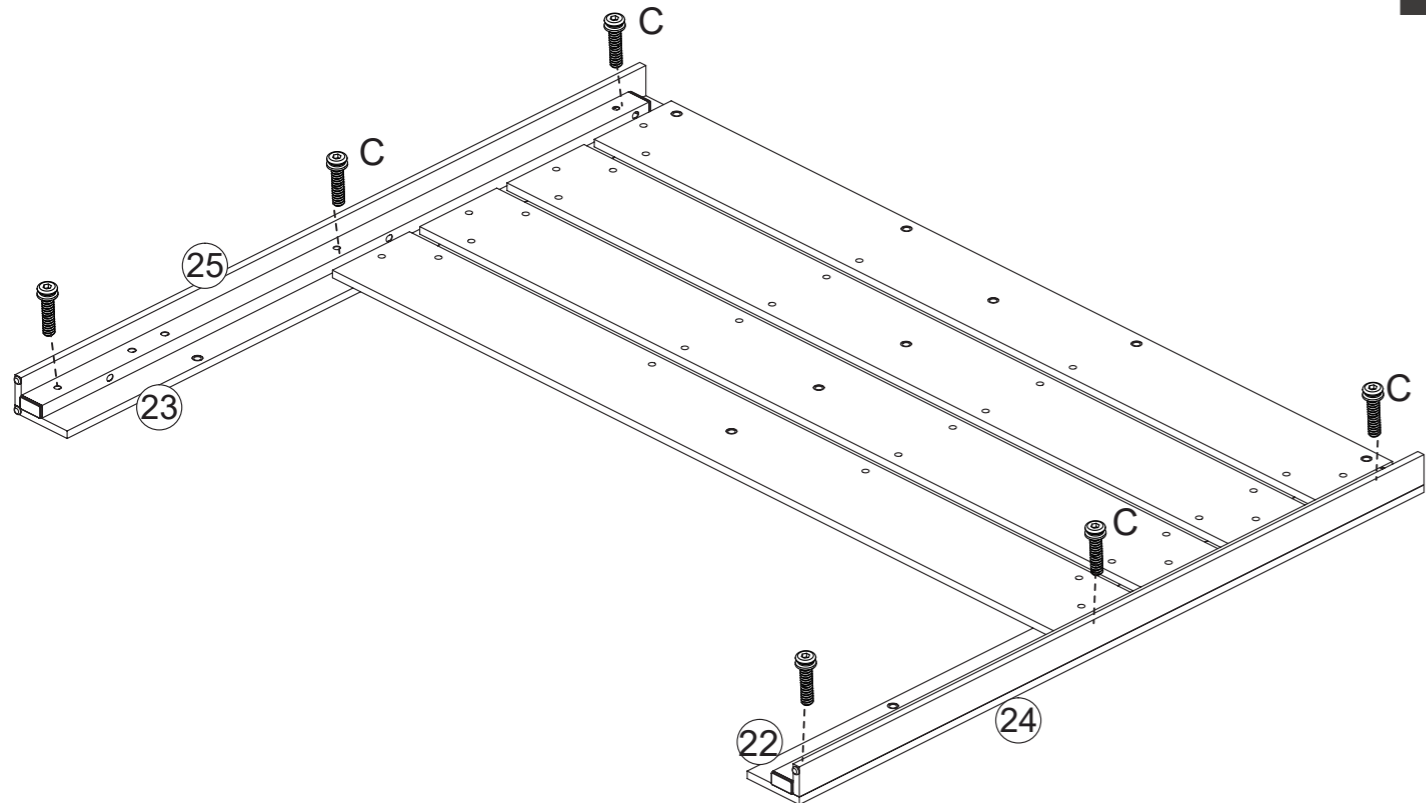

4

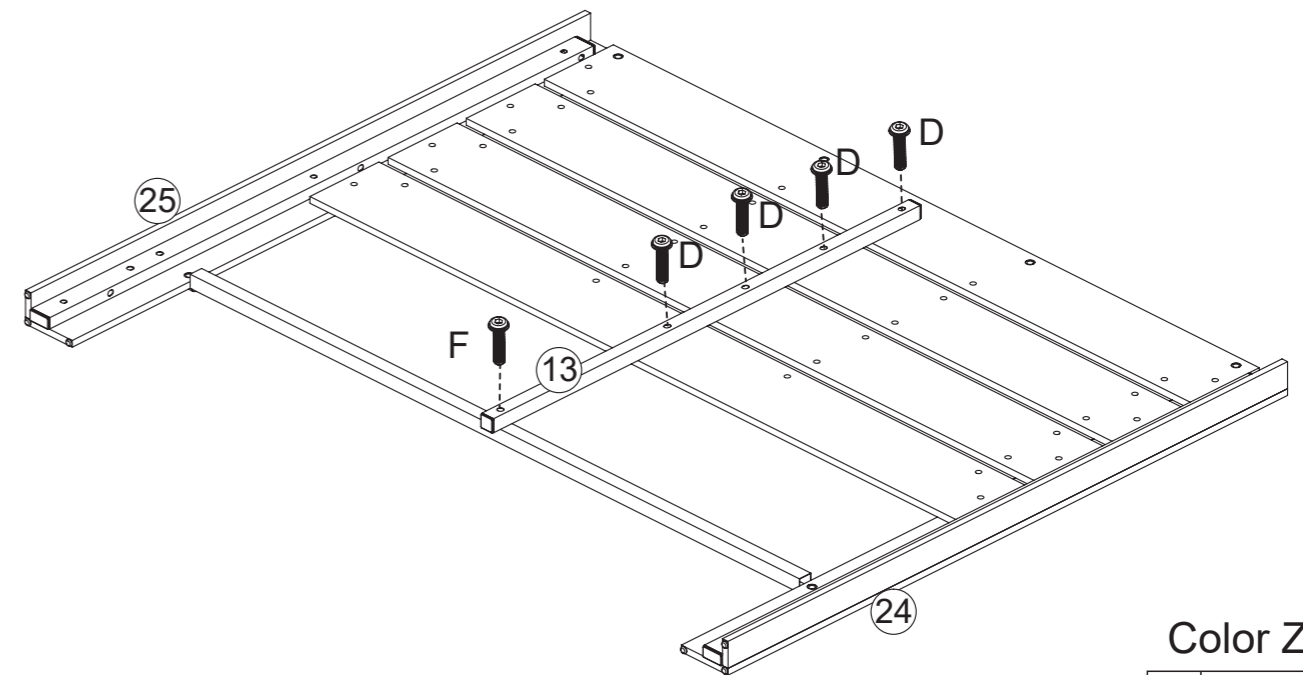

C		M8*30	6PCS
---	---------------------------------------------------------------------------------------	-------	------

6



Color Zinc			
D		M8*35	4PCS
F		M8*50	1PC

ASSEMBLY INSTRUCTIONS

In this installation step, please ensure that the side of component 18 with the hole positioned closer is facing upward

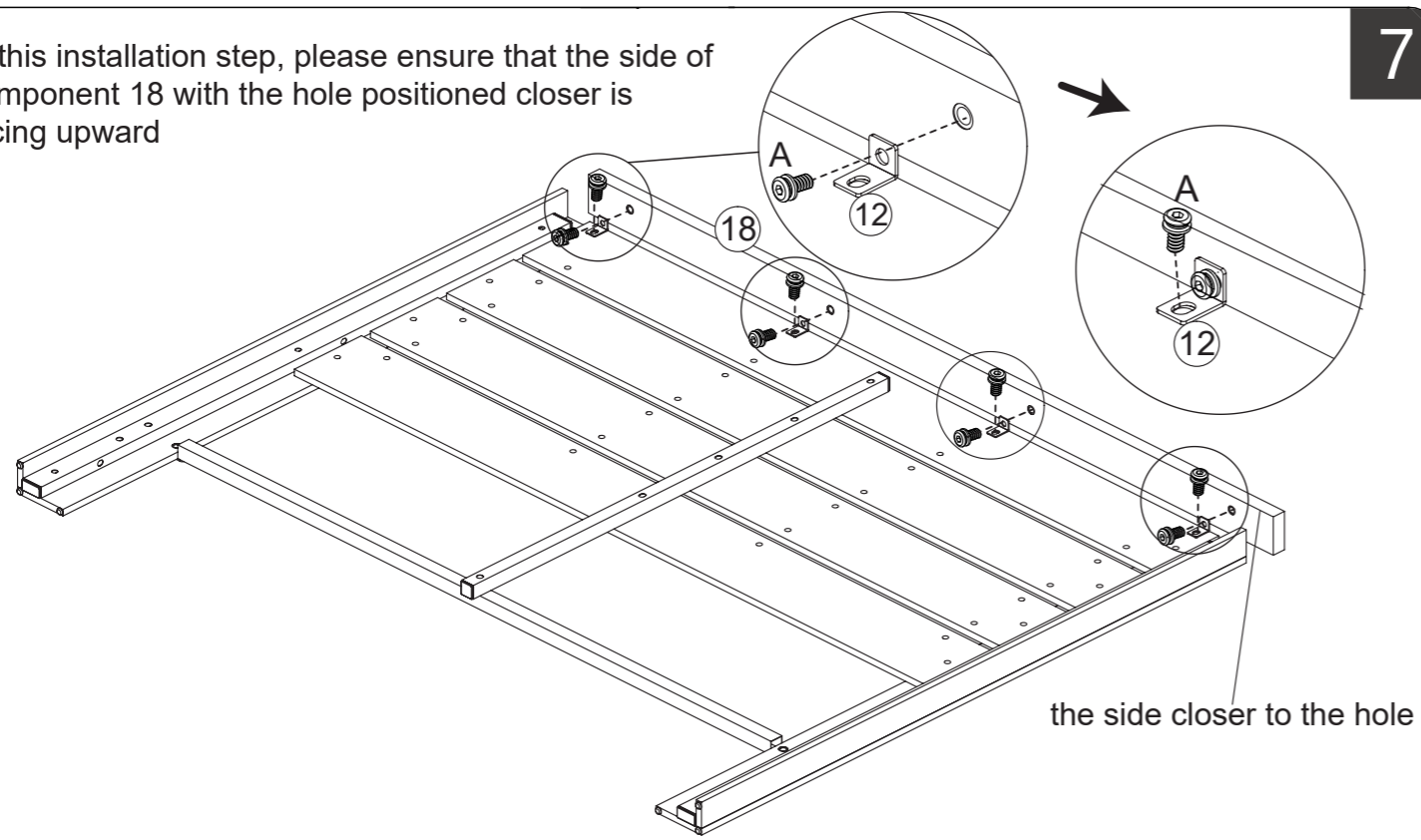

7

A M8*12 8PCS

ASSEMBLY INSTRUCTIONS

Note: The hole in this direction is facing upwards

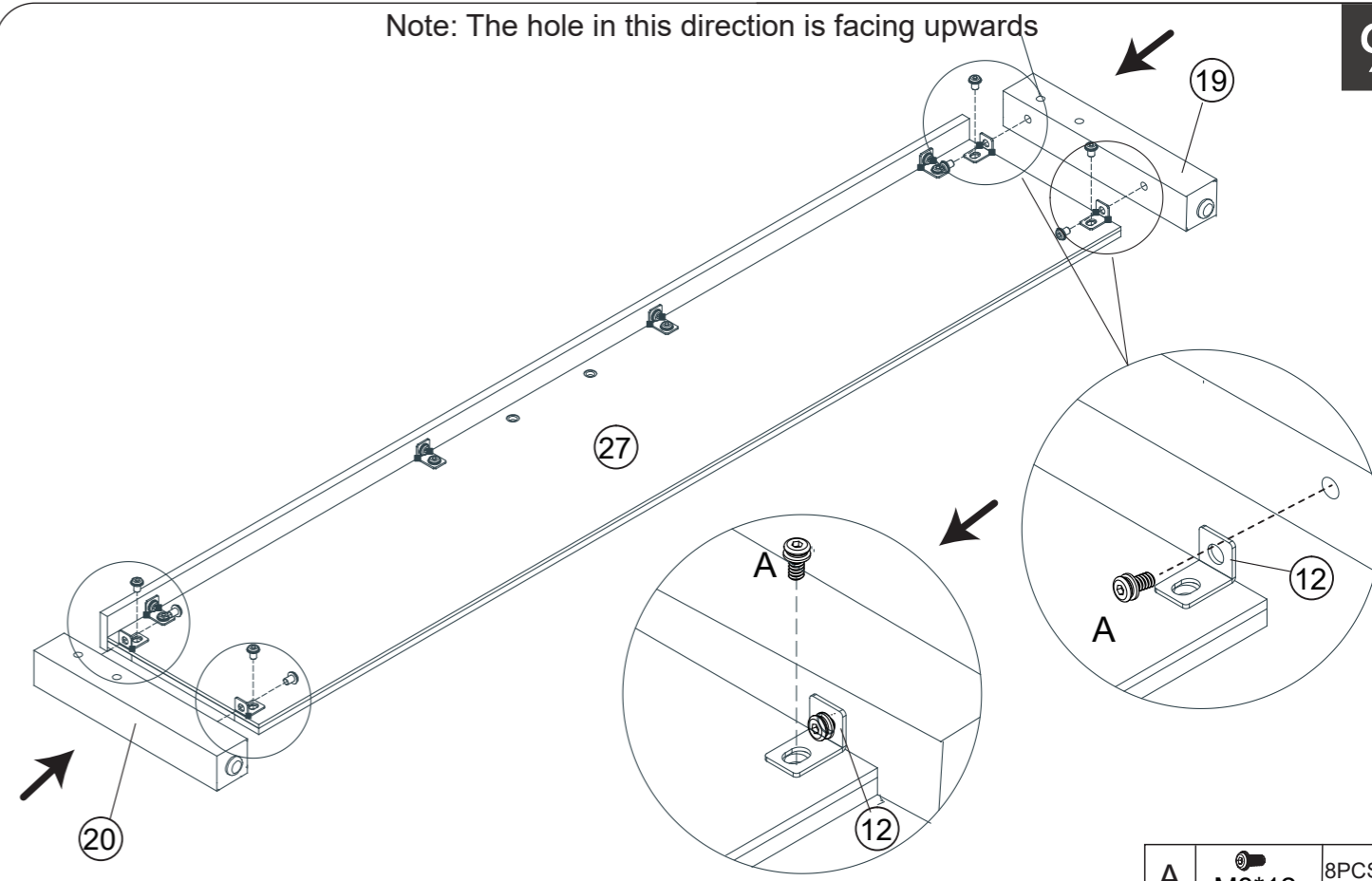

9

A M8*12 8PCS

In this installation step, please ensure that the side of component 21 with the hole positioned closer is facing upward

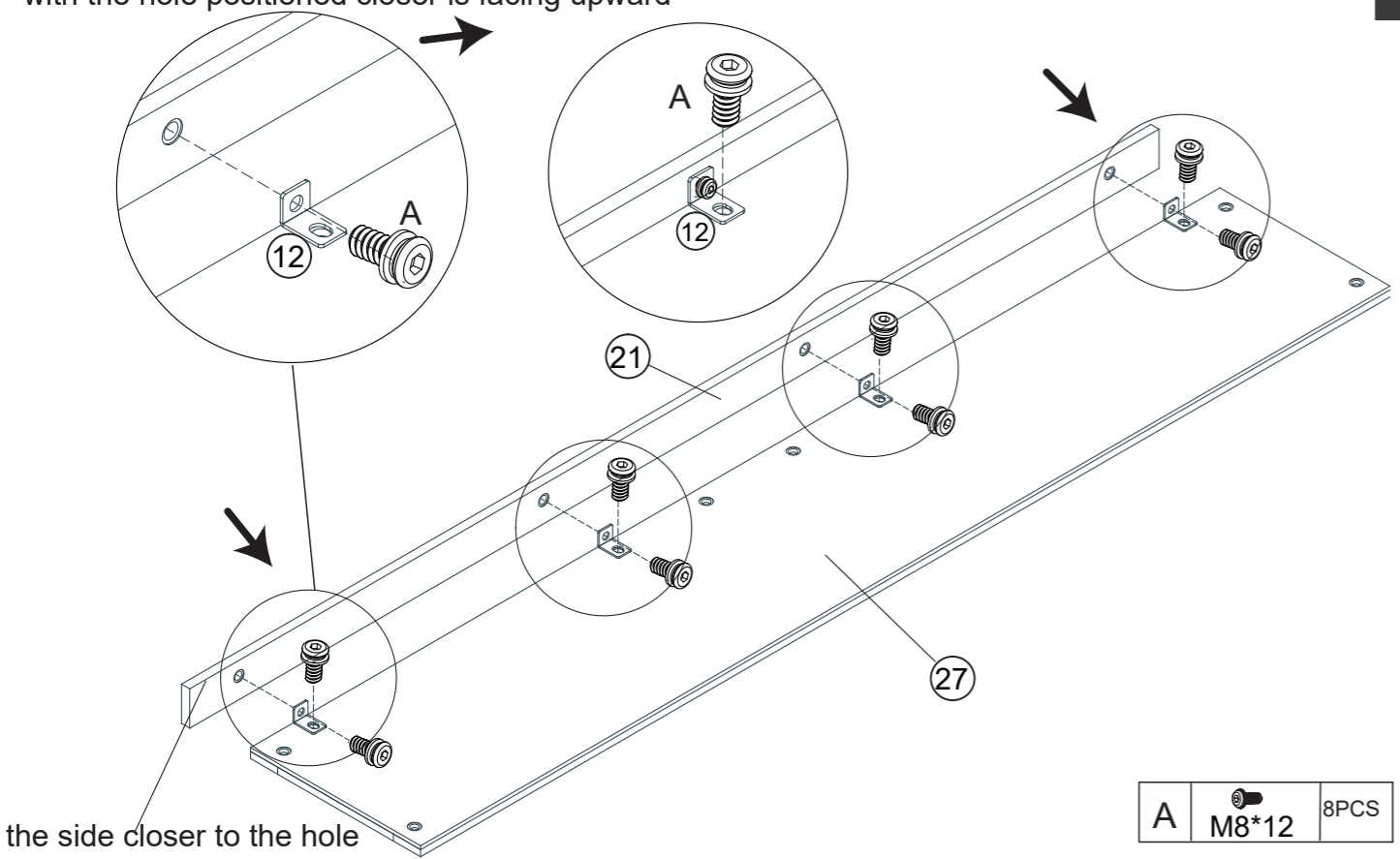

8

A M8*12 8PCS

10

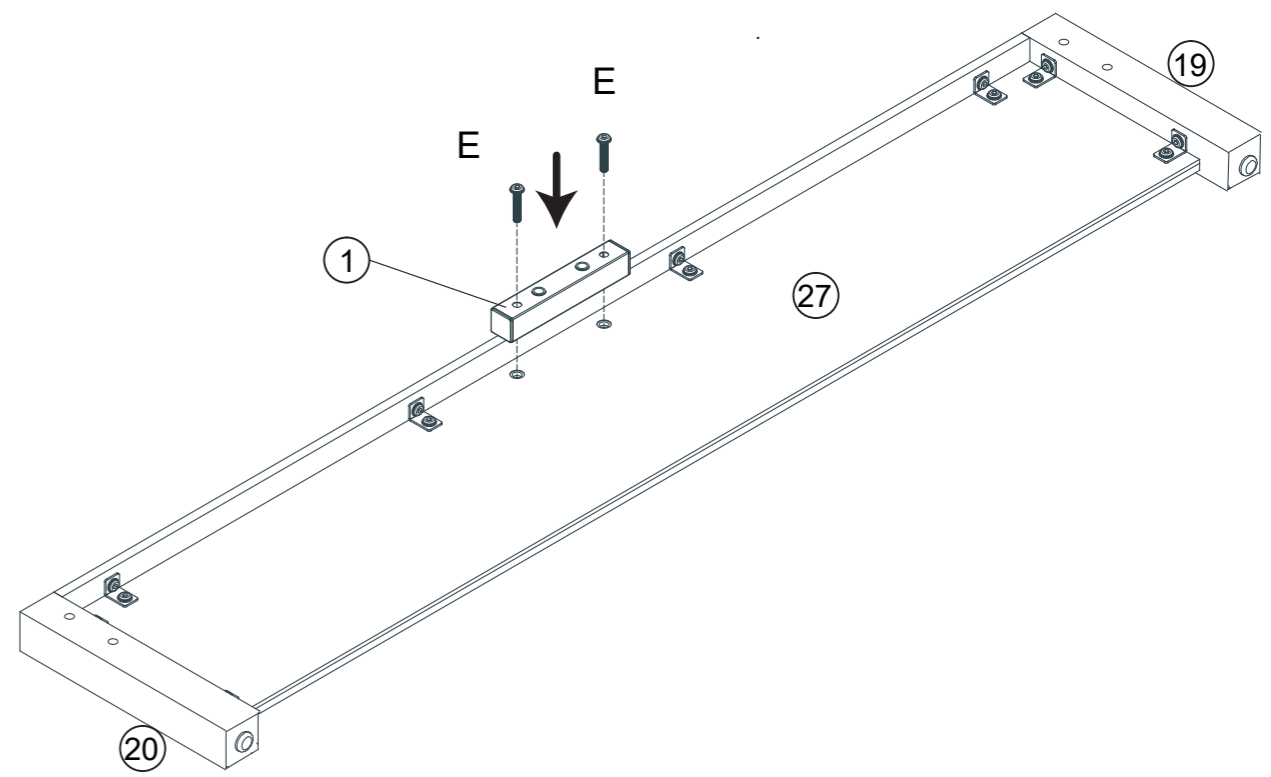

E M8*40 2PCS

ASSEMBLY INSTRUCTIONS

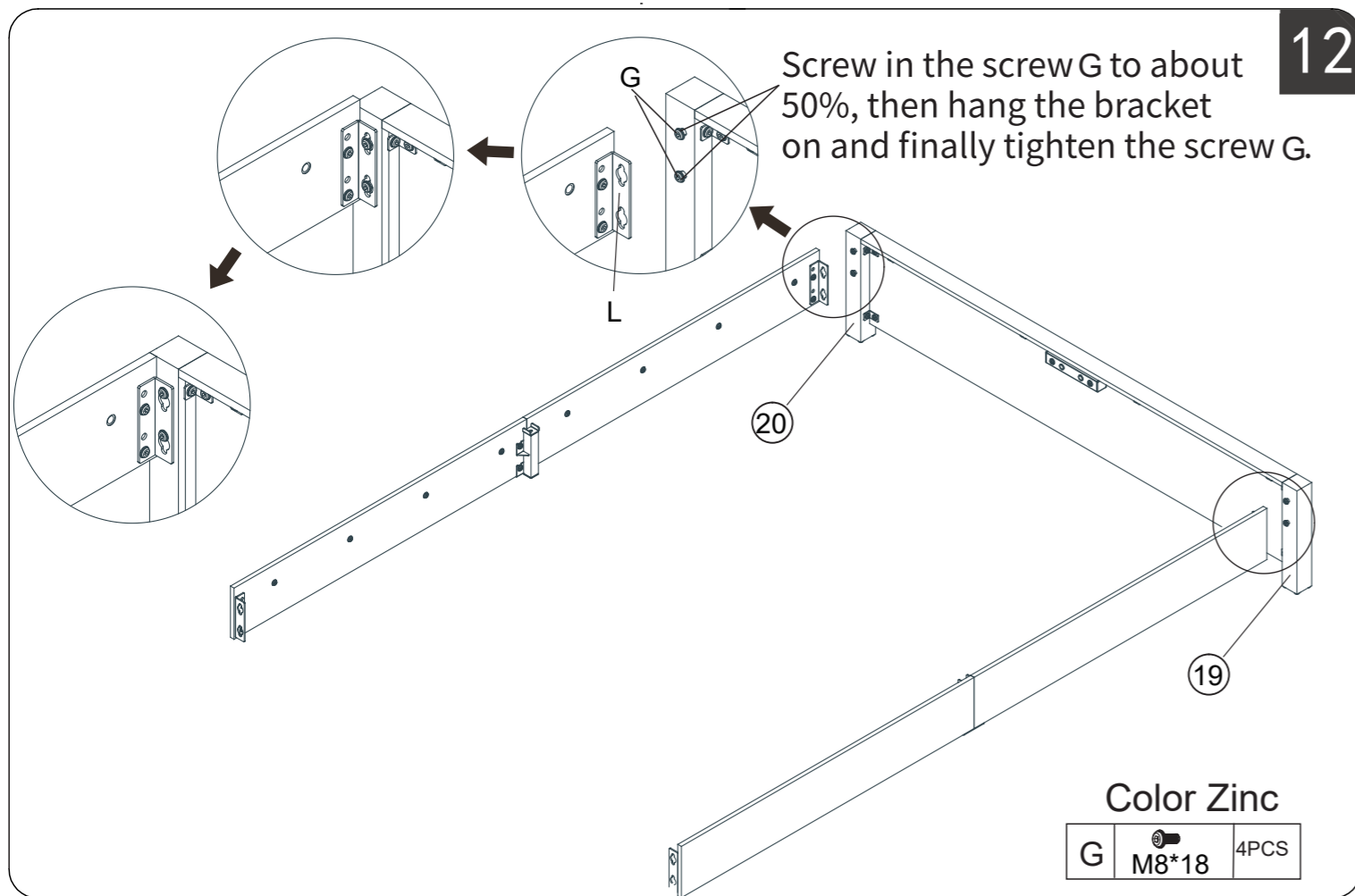
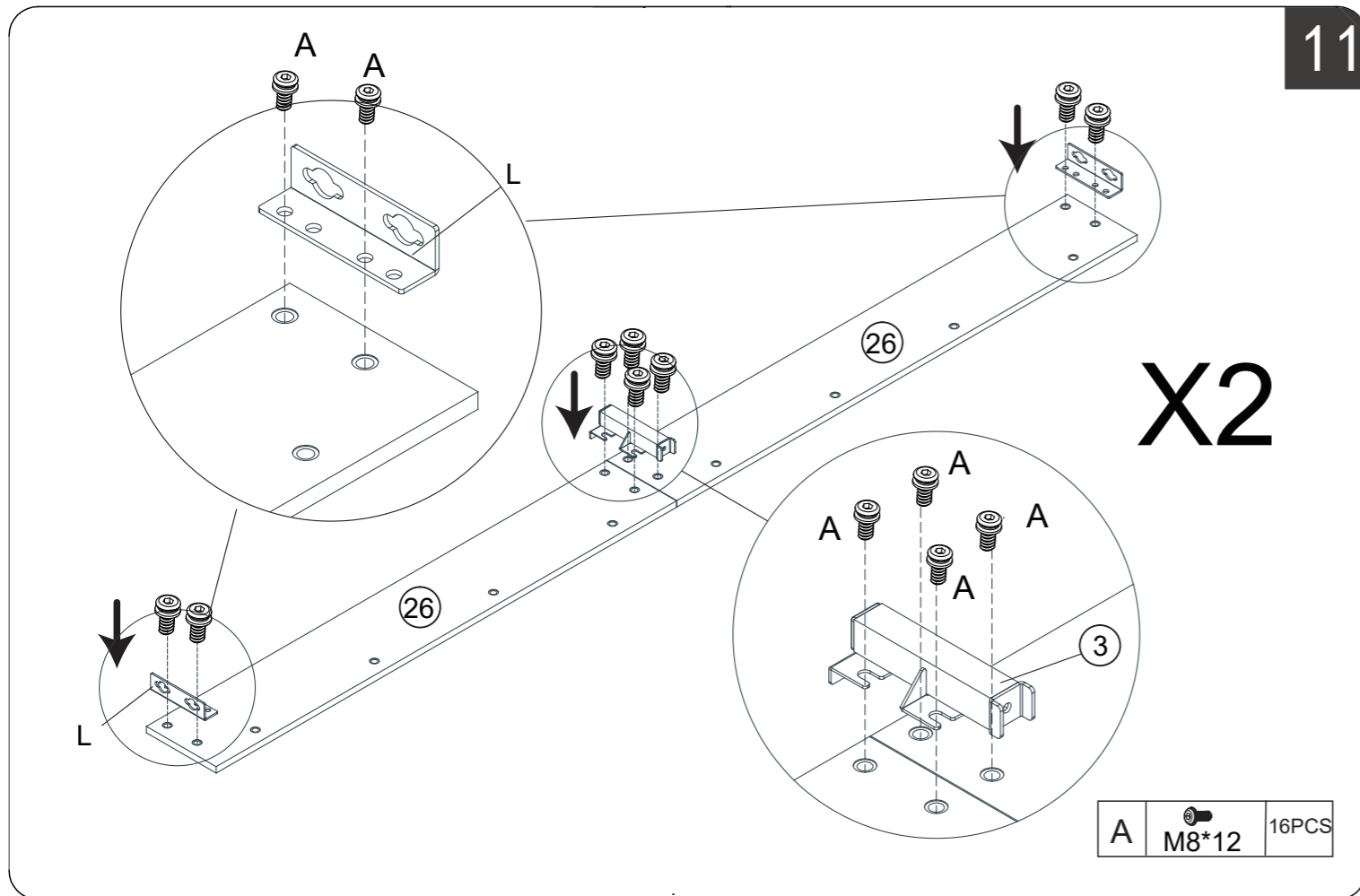

ASSEMBLY INSTRUCTIONS

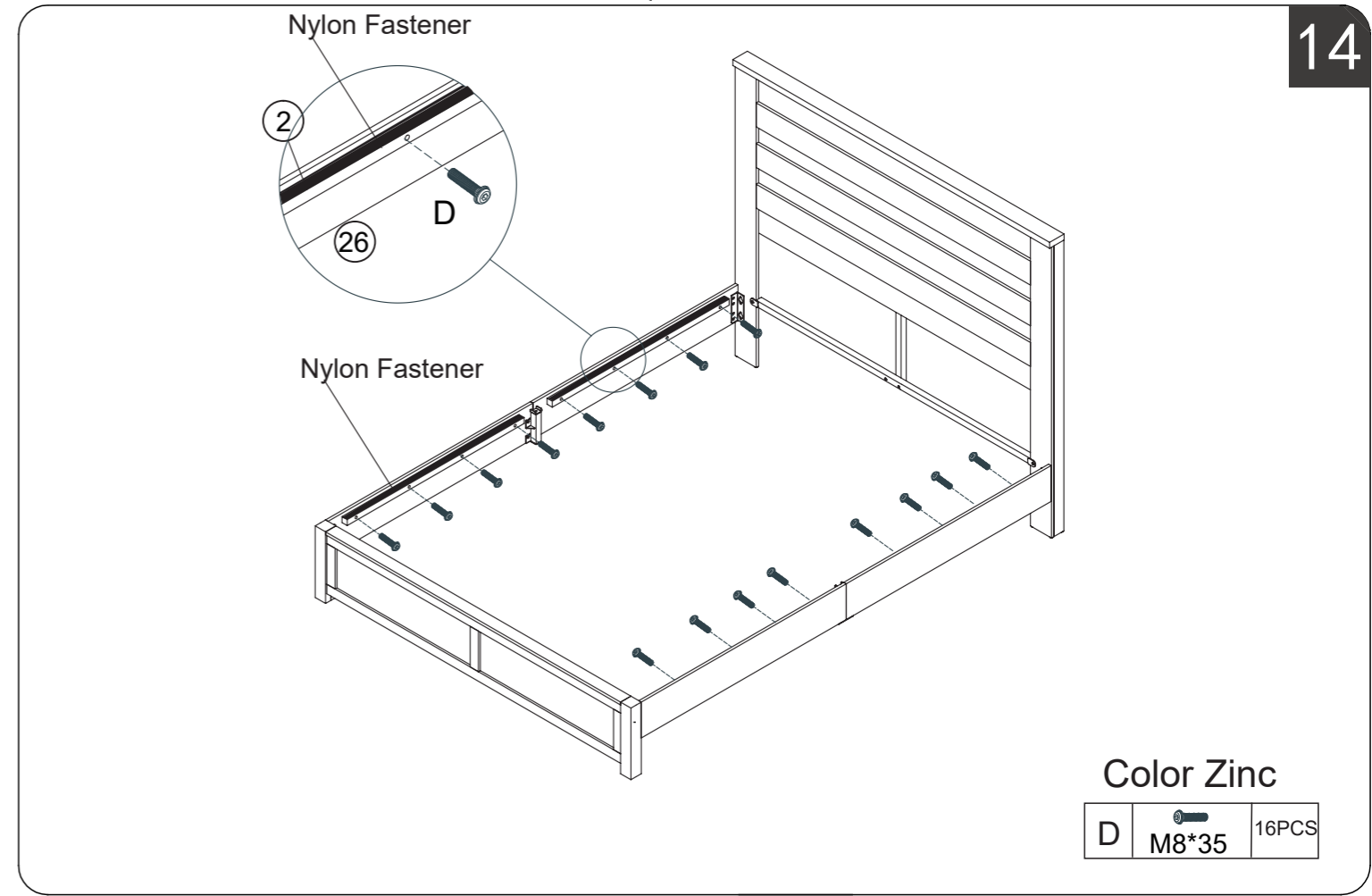
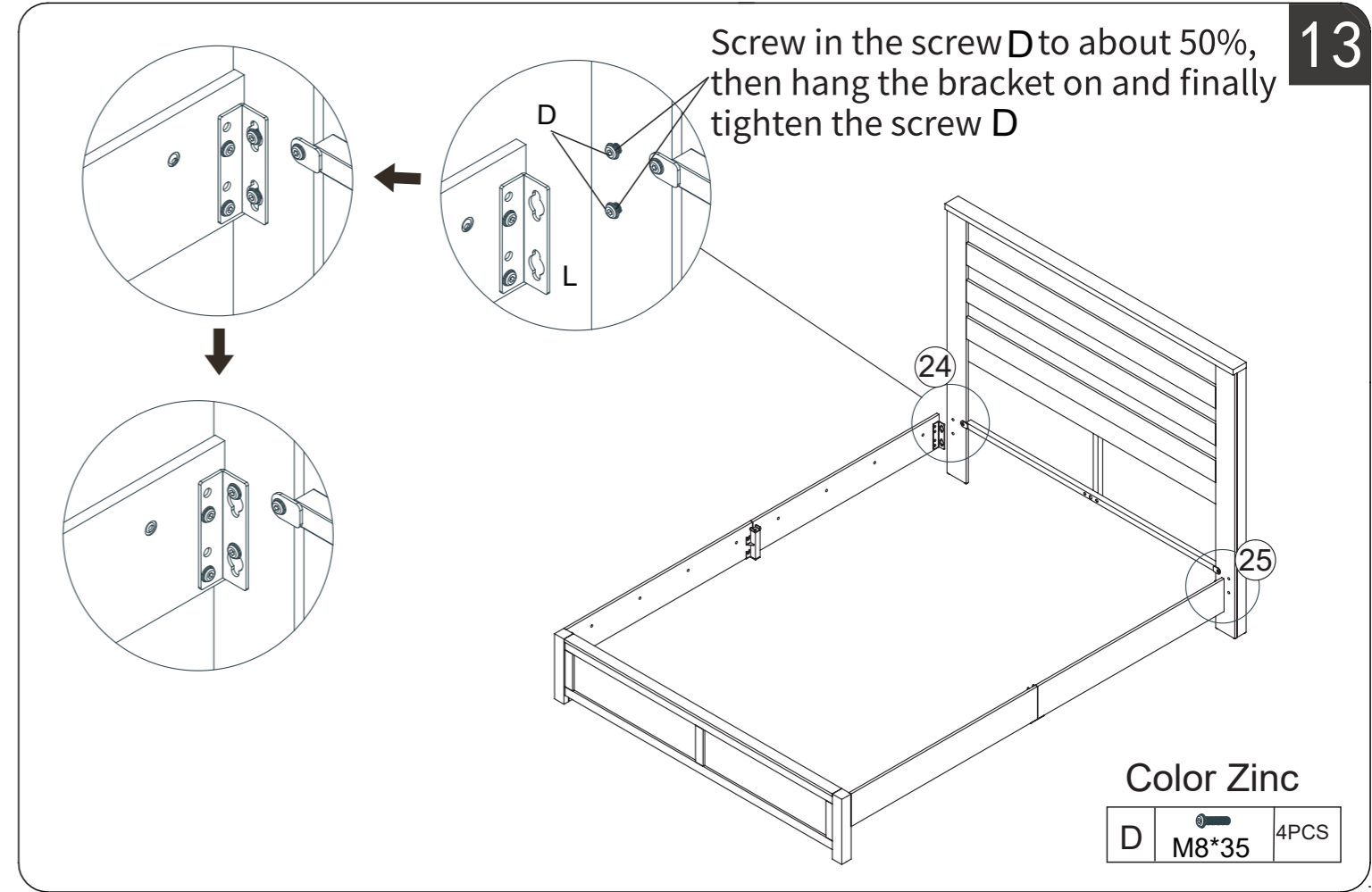

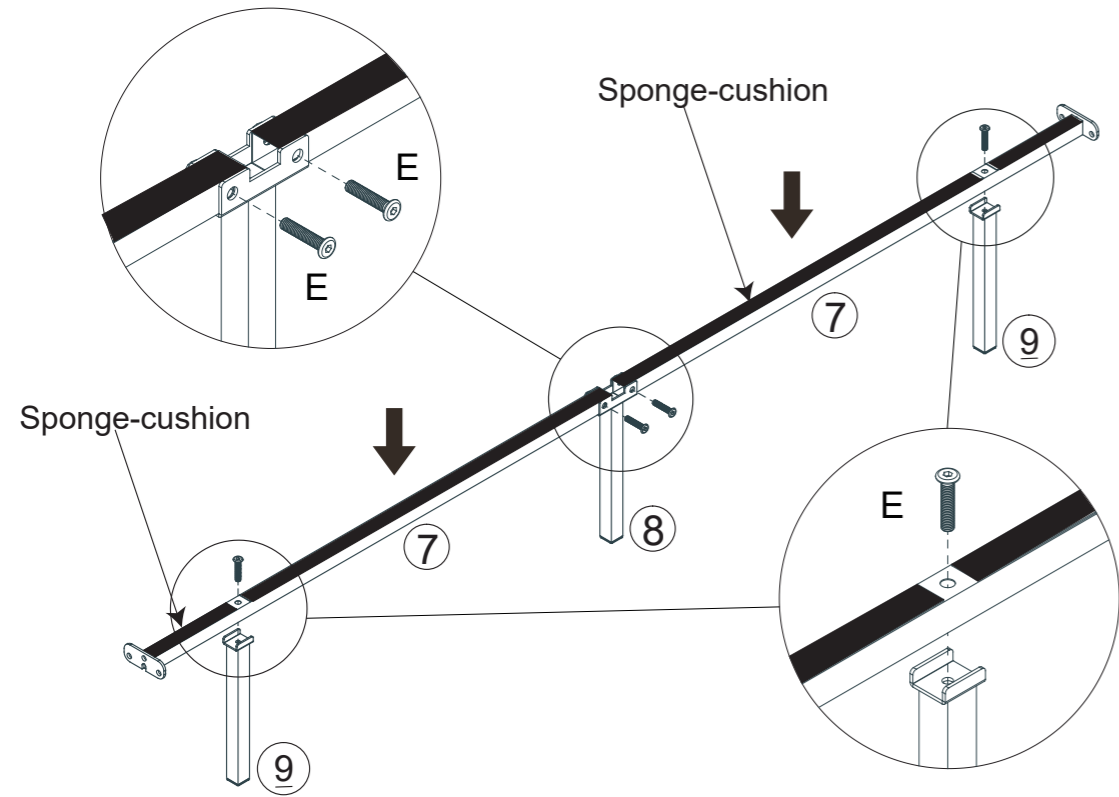

15

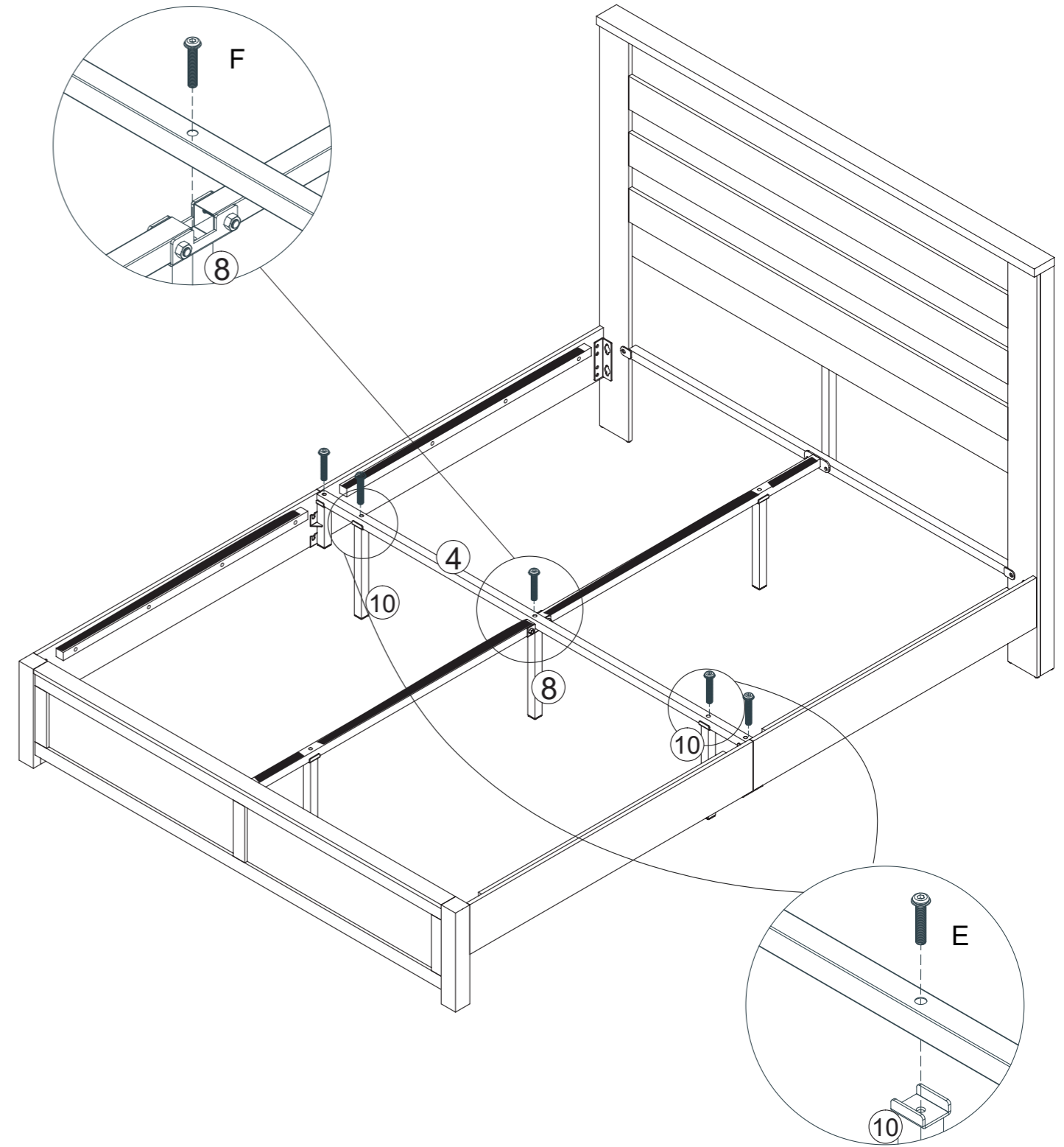

E		M8*40	4PCS
---	--------------------------------------------------------------------------------------	-------	------

17



F		M8*50	1PCS
E		M8*40	4PCS

16

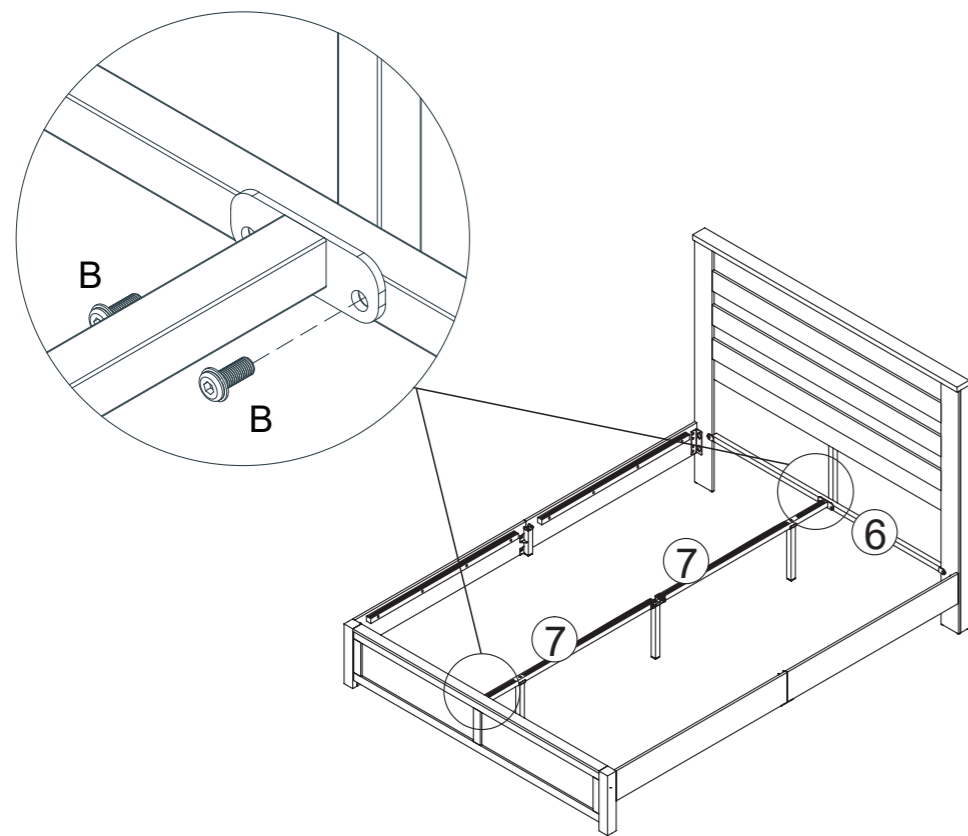

B		M8*20	4PCS
---	---------------------------------------------------------------------------------------	-------	------

step 1

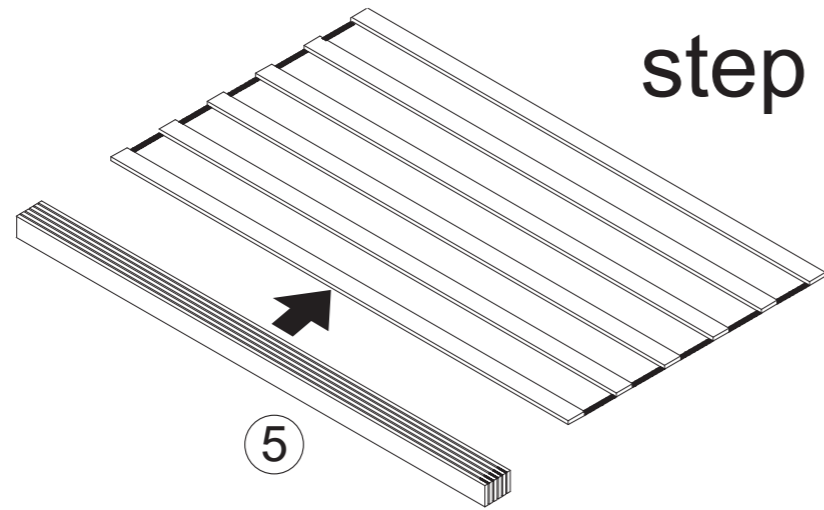

step 2

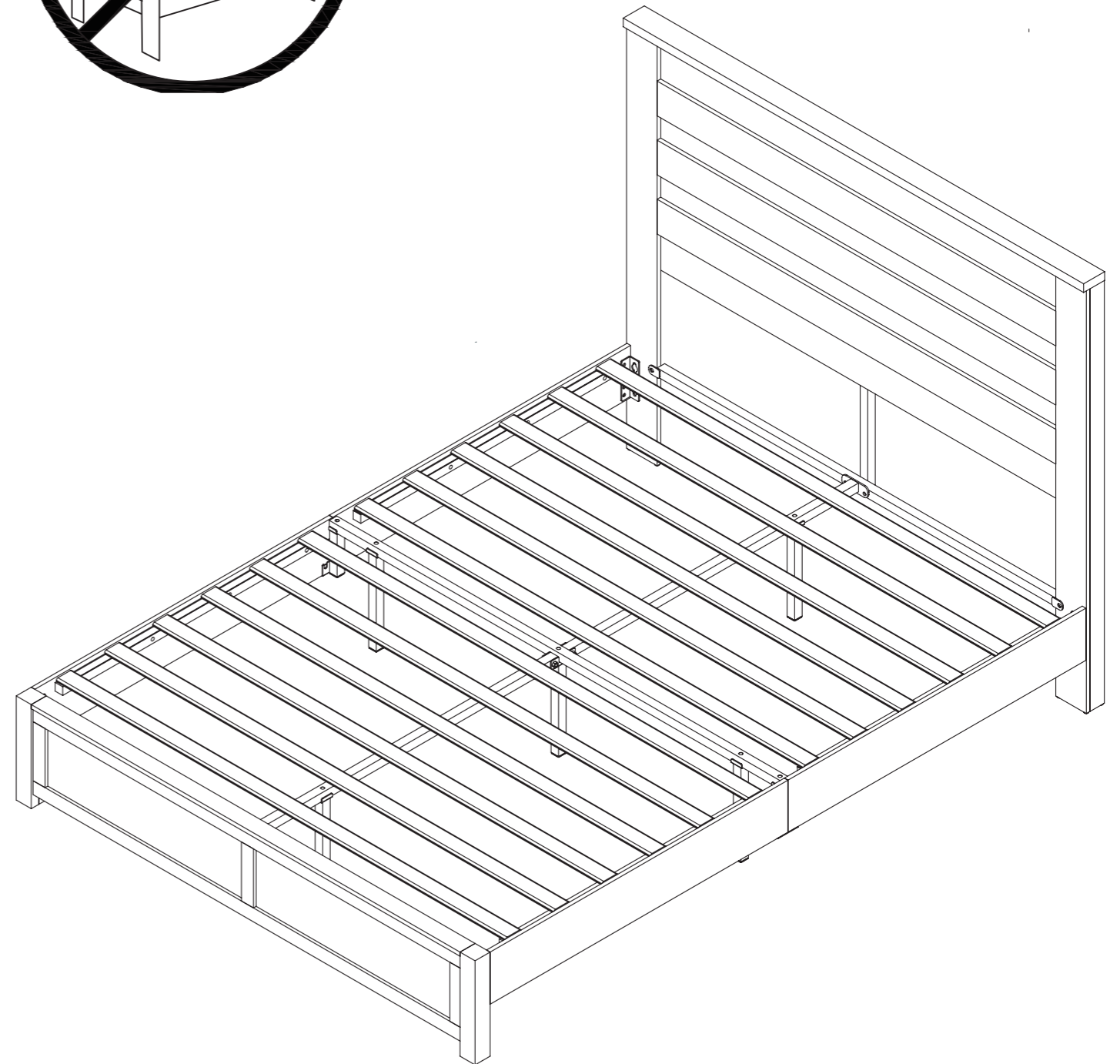
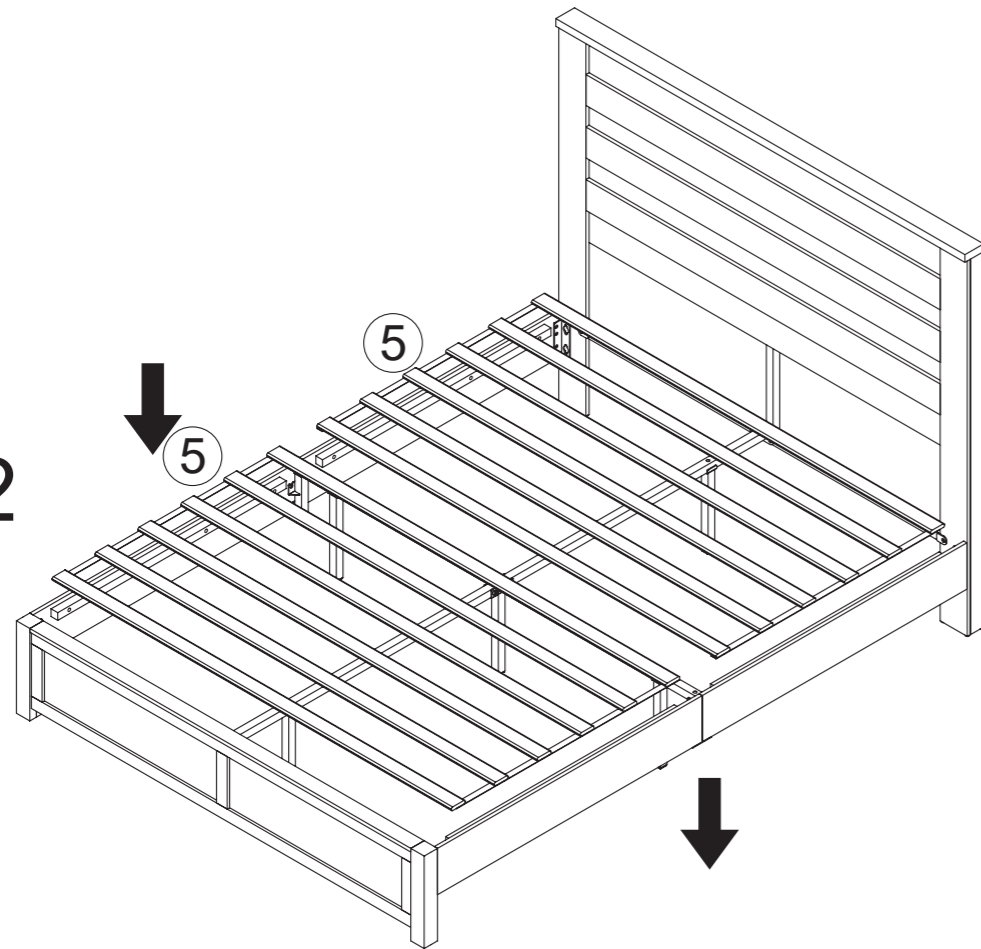

Installation Complete