

WOODEN RAISED GARDEN BED INSTRUCTION MANUAL

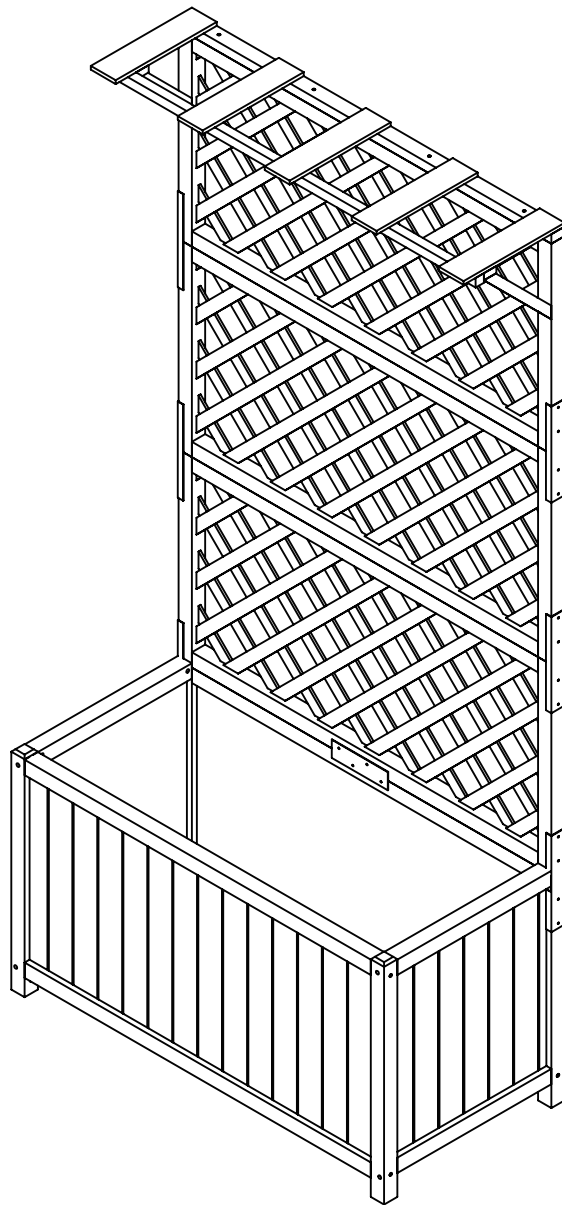

SKU:
YRB100-2A1A0
YRB100-2A2A0

We appreciate your trust and the purchase of the products.

We are always committed to selling higher-cost performance products, and try our best to provide our customer service with brilliant quality.

Improve your living experience from purchase Amerlife products will be our pleasure.

! NOTICE

Please retain instructions for future needs.

- Do not stand on or use any parts of this item as a step ladder.
- Fasten screws loosely during assembly. Do not firmly tighten the screws until the item is completely assembled.
- Double-check all the bolts, screws, and knobs have been firmly tightened before use.
- To prevent items fall apart, please regularly check if all bolts, screws, and knobs are secure.
- Do not use or store this item in the proximity of open flame or flammable/combustible
- Be aware that some parts are heavy and have sharp edges when assembling and using.
- If any parts are missing, broken, damaged, or worn in 90 days, stop using or assembling this product, please do not hesitate to contact us, we will send the factory replacement parts for free.
- Do not use this item in a way inconsistent with the manufacturer's instructions as this could void the
- This item is made of wood and may expand due to moisture.

TOOLS REQUIRED

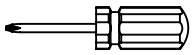

PHILLIPS
SCREWDRIVER



1 PERSON
ASSEMBLY



APPROXIMATELY
20 MIN.
ASSEMBLY

HARDWARE

A



M4x30mm

4 pcs

B

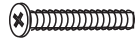

M6x50mm

8 pcs

C



M3x18mm

32 pcs

D



M4x35mm

4 pcs

E



M 3.5x60mm

8 pcs

PARTS

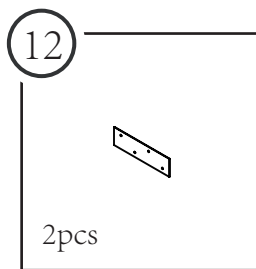
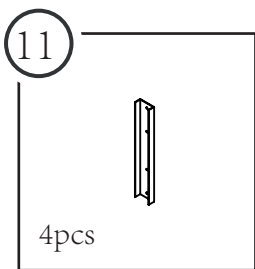
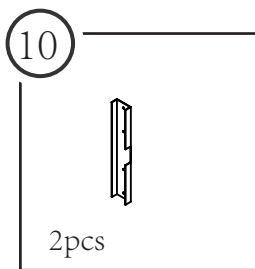
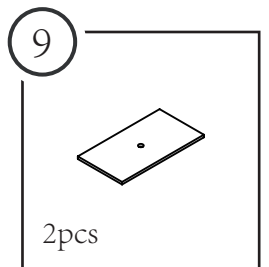
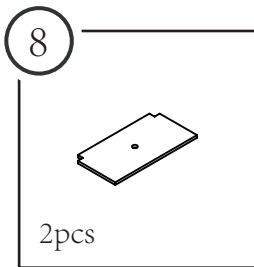
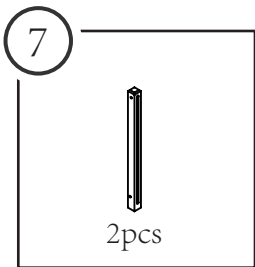
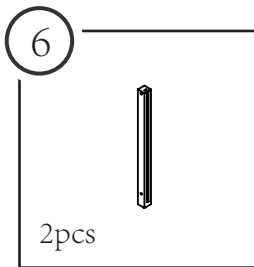
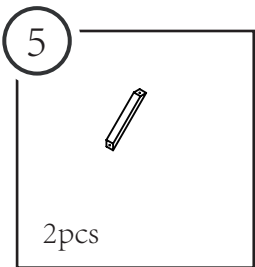
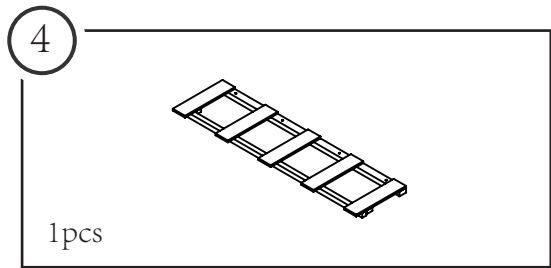
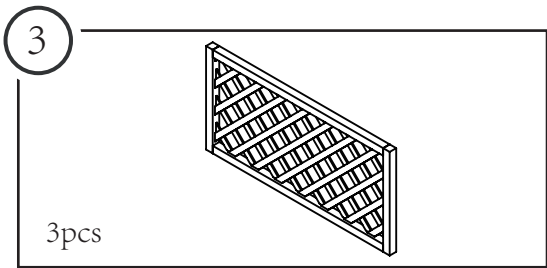
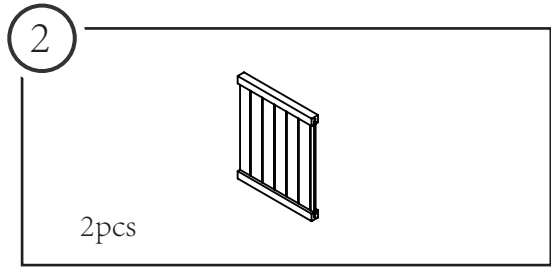
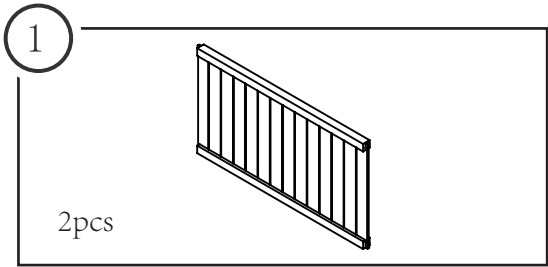

PRODUCT ASSEMBLY

1

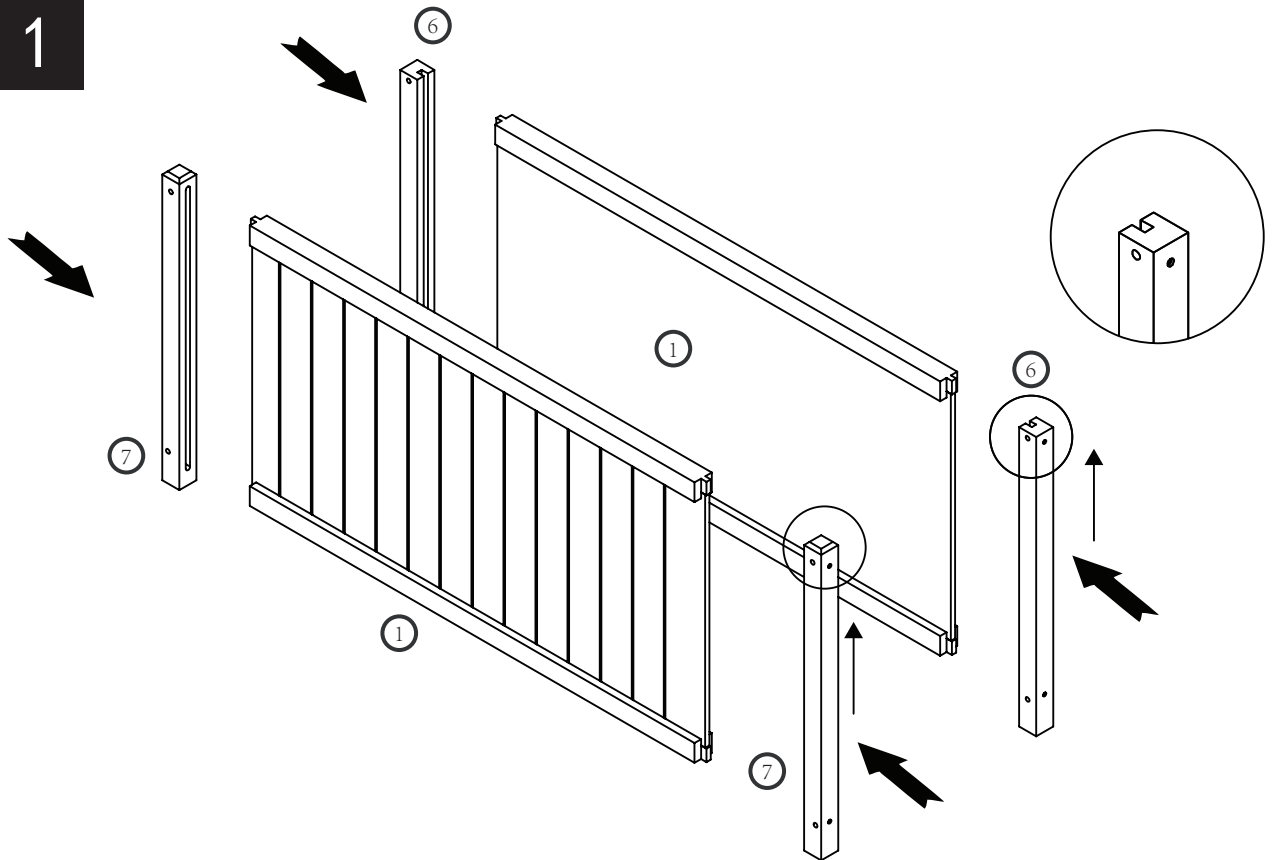

2

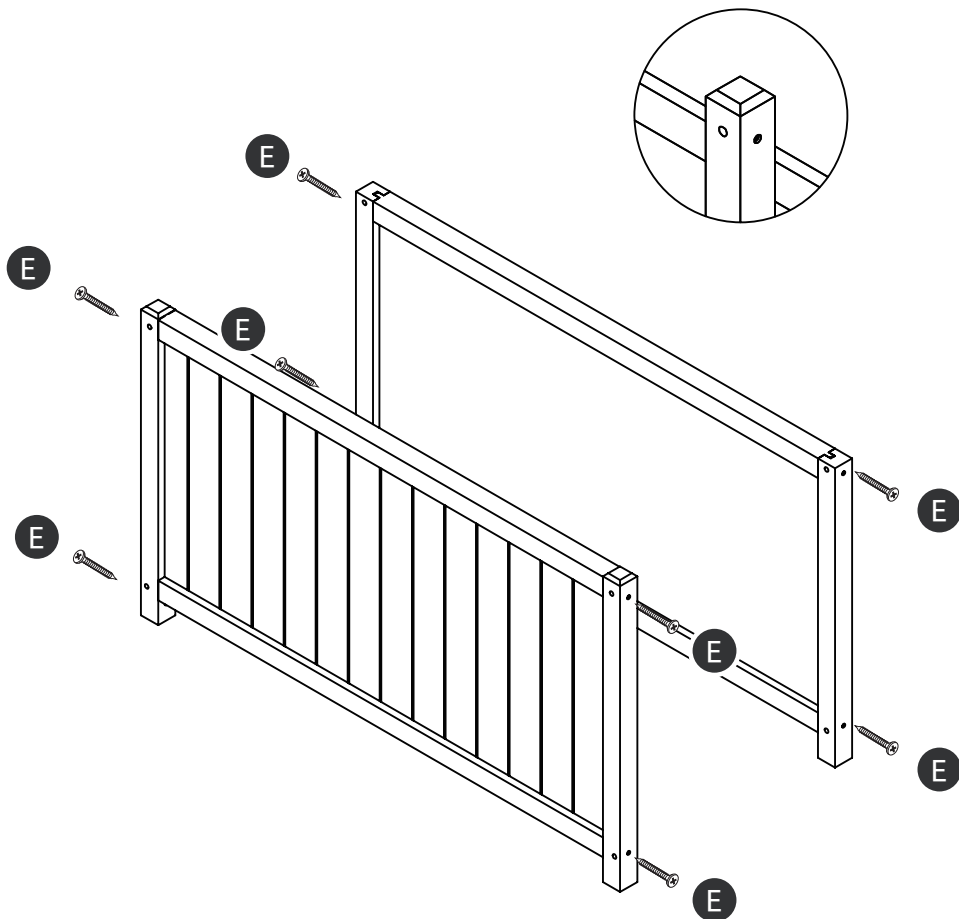

M 3.5x60mm

PRODUCT ASSEMBLY

3

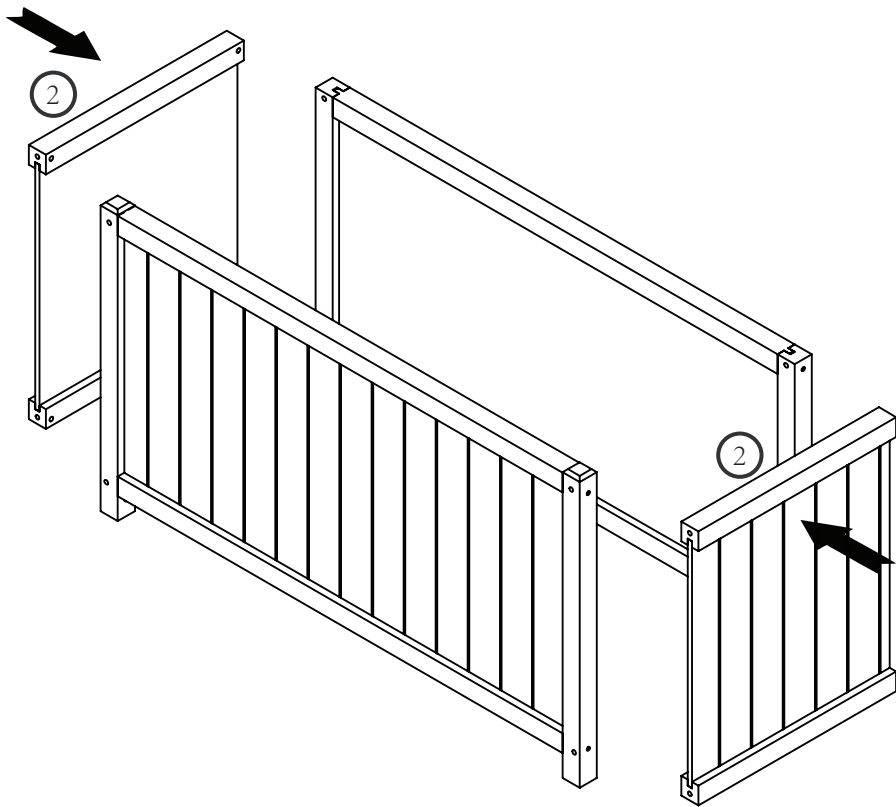

PRODUCT ASSEMBLY

4

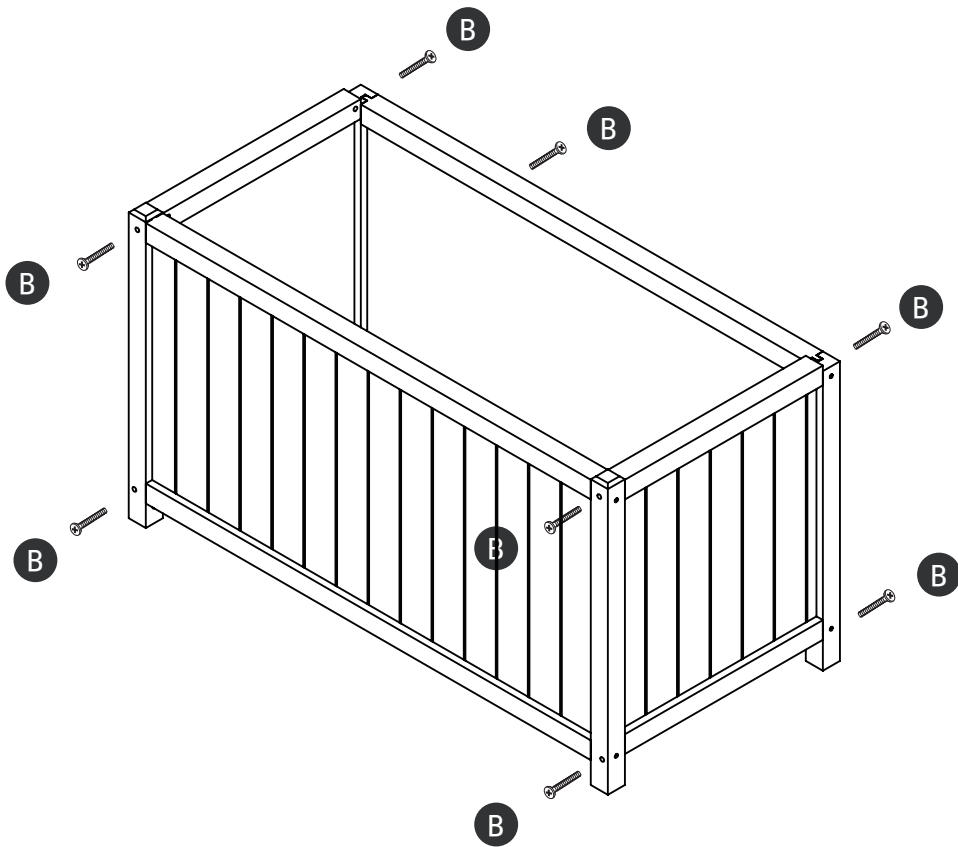

B  M6x50mm

PRODUCT ASSEMBLY

5

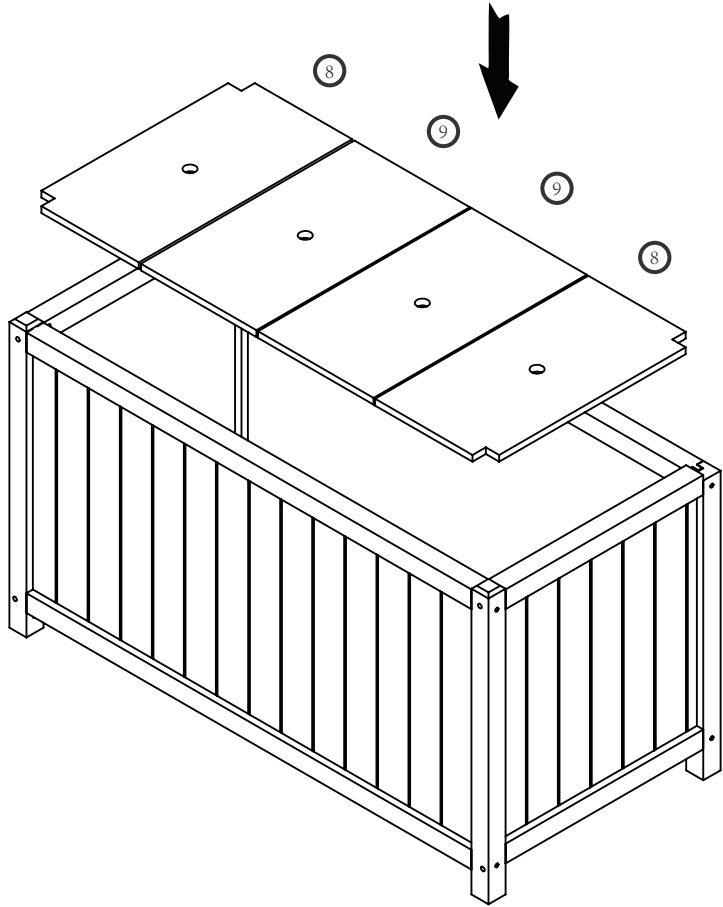

PRODUCT ASSEMBLY

6

C  M3x18mm

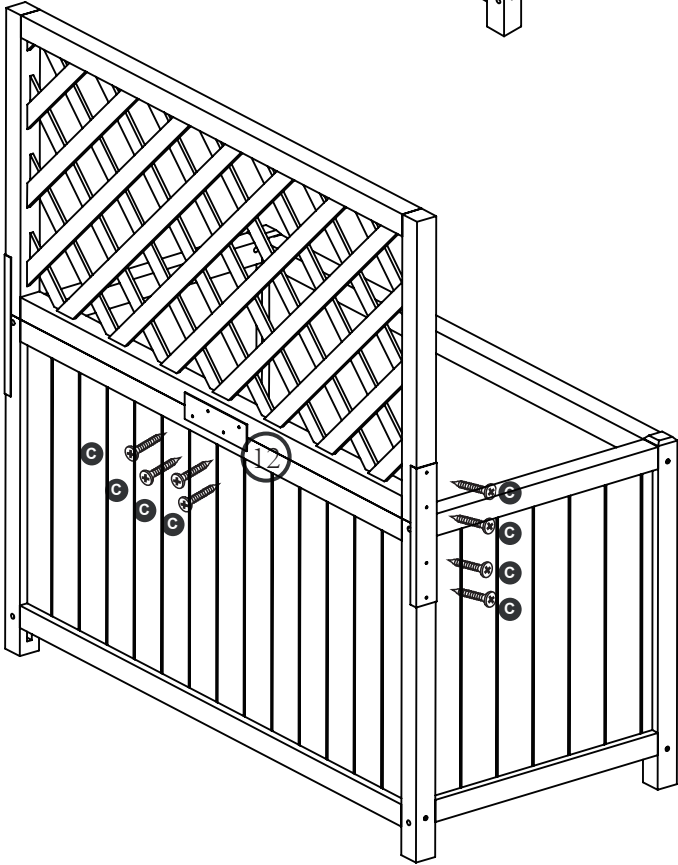
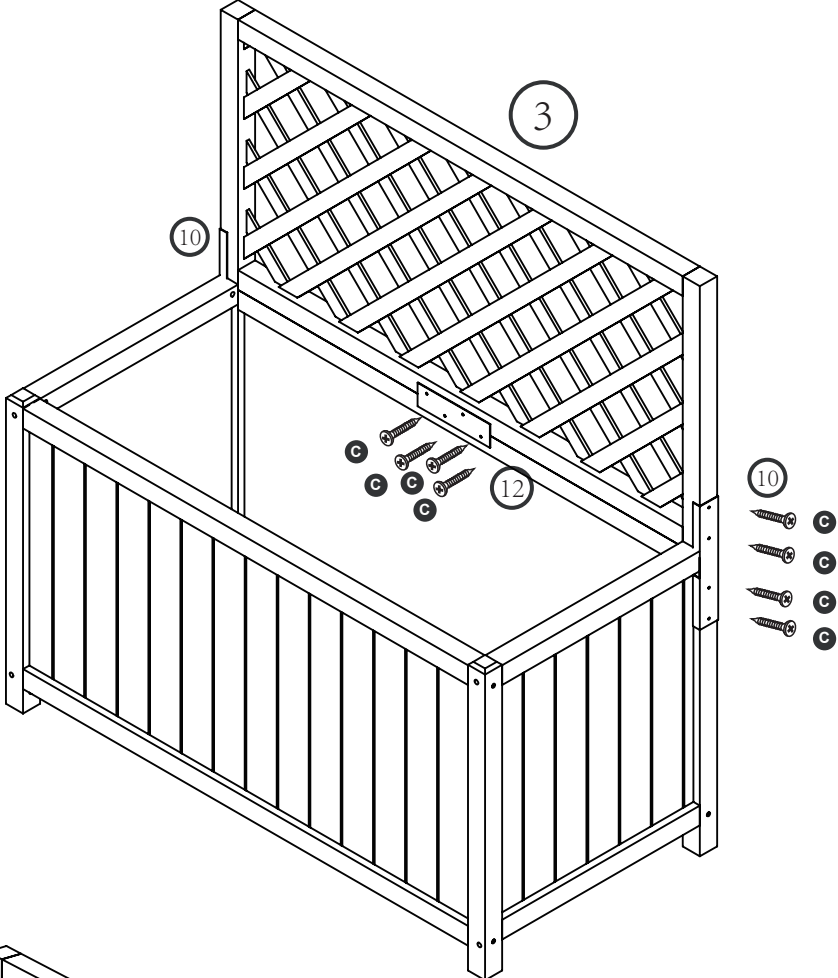

PRODUCT ASSEMBLY

7

C  M3x18mm

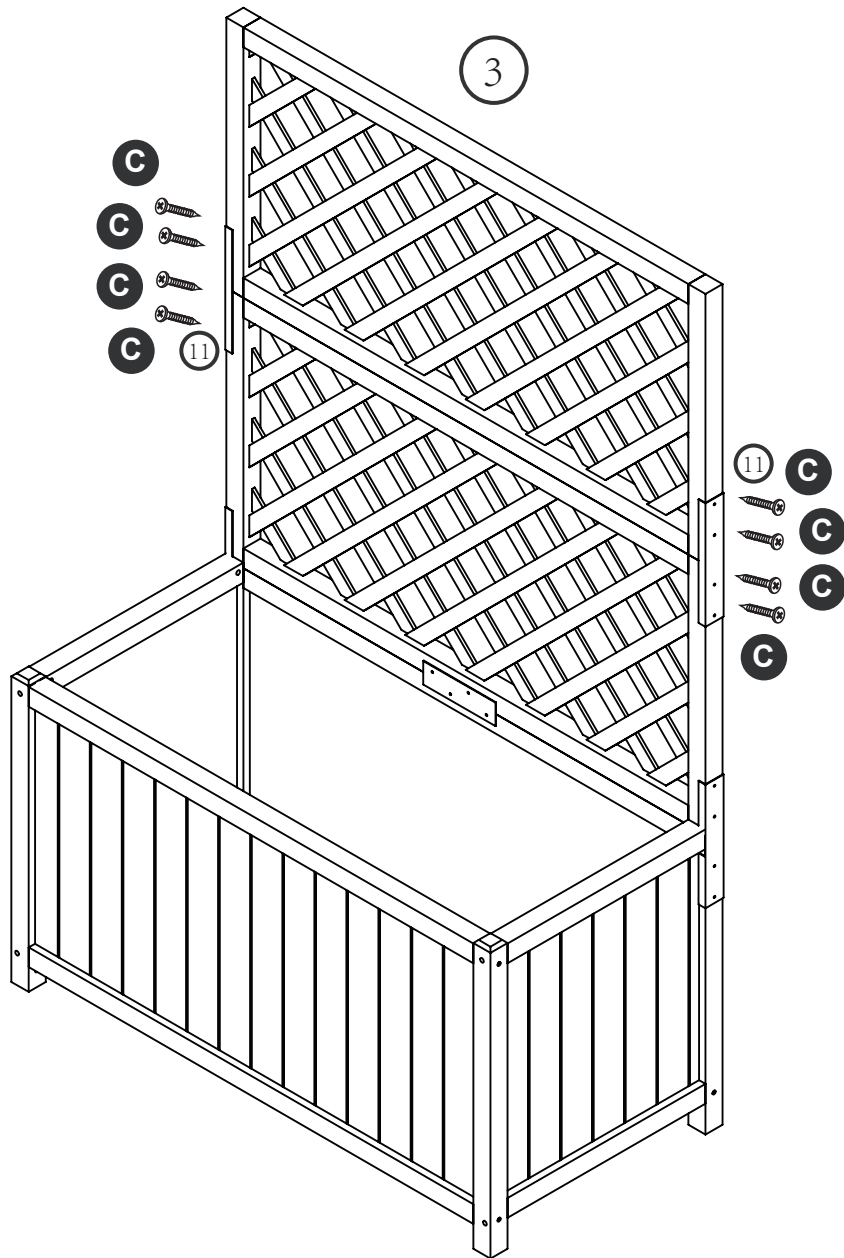

PRODUCT ASSEMBLY

8

D  M4x35mm

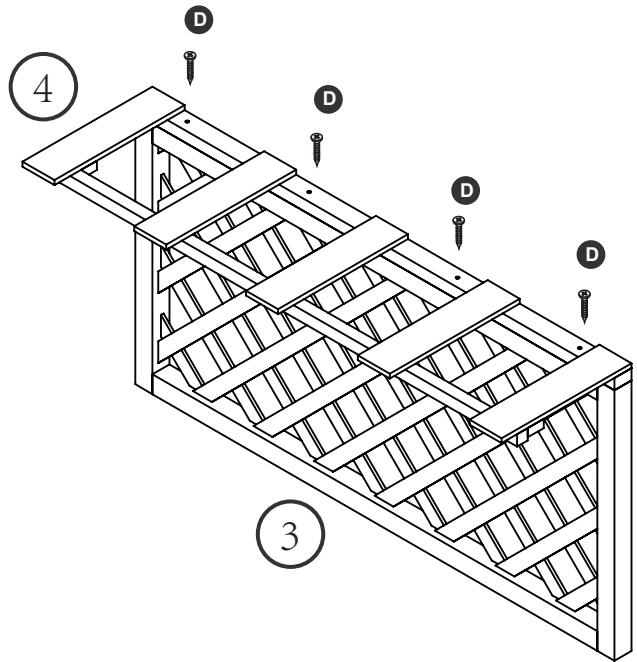

9

A  M4x30mm

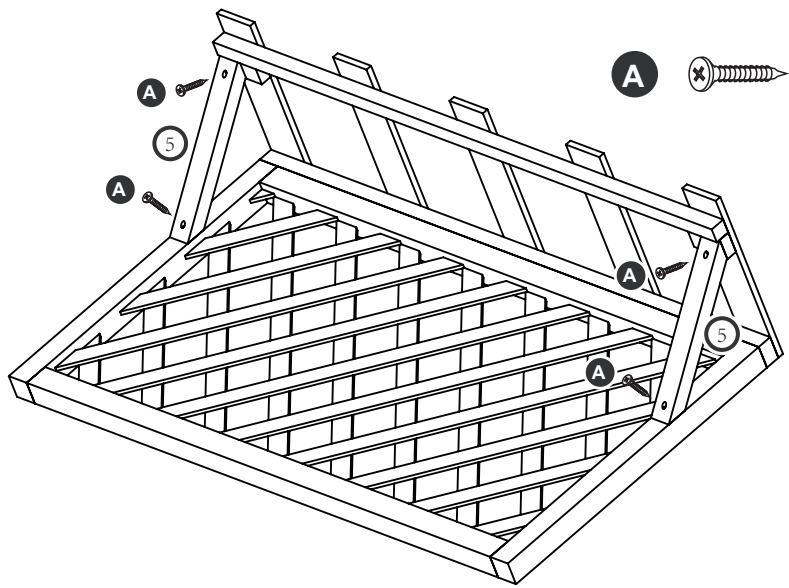

PRODUCT ASSEMBLY

10

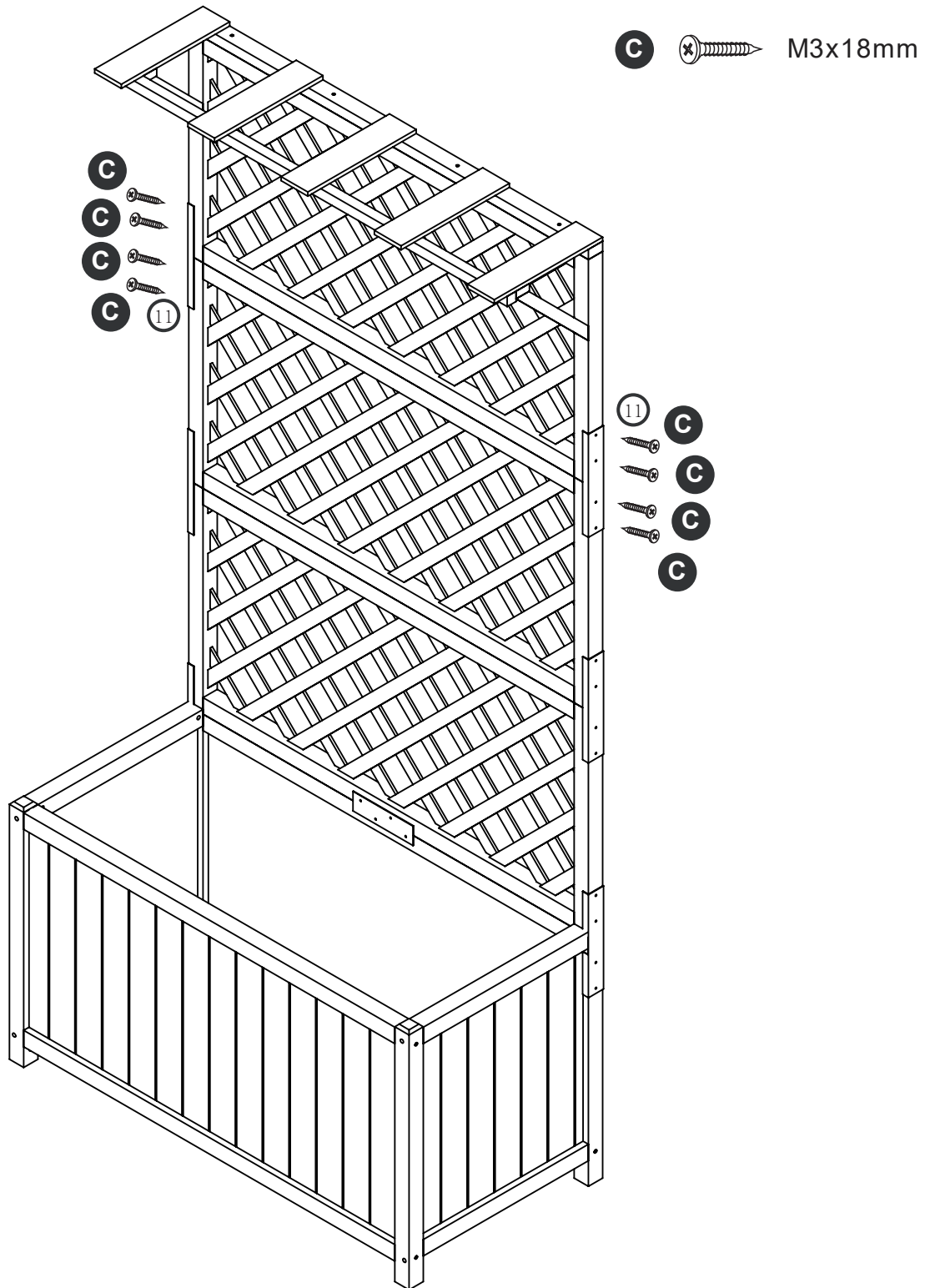

CUSTOMER SERVICE GUIDE

Thank you for choosing our product! We are committed to providing you with excellent service. If you find any missing parts, damaged packaging, or product damage after receiving all packages, please follow the steps below to quickly contact our customer service team. We will do our best to resolve your issue.

1. Missing Parts

Verify Parts:

1. Refer to the “Parts List” in the manual to verify the name, specifications, and quantity of the missing parts.
2. Take a clear photo of the parts list and mark the missing parts with detailed information, e.g., “Missing 5 pieces of M6X30mm screws.”

Contact Us:

· By Email:

Send an email to service@grandtunnel.com, with the subject line “Missing Parts Issue.” Include the following in the email:

- A description of the missing parts and a photo of the parts list.
- Order details (order number, purchase platform, purchase date).

2. Product or Packaging Damage

If it affects normal use:

Steps:

1. Take clear photos or videos showing the damaged parts and the extent of the damage (multiangle shots are recommended).
2. Email the photos/videos along with order details to service@grandtunnel.com, with the subject line “Product Damage Issue.”

Resolution:

After verification, we will arrange for a replacement part, product exchange, or refund as quickly as possible.

If it does not affect normal use:

Steps:

1. Contact our customer service team (by email: service@grandtunnel.com).
2. Provide a description of the damage and include relevant photos or videos.

Resolution:

We will provide repair guidance or an appropriate compensation plan based on the specific situation.

Contact Us:

- Customer Service Email: service@grandtunnel.com

Helpful Tips

To process your issue efficiently, please prepare the following information:

- Order details (order number, purchase platform, purchase date).
- Clear photos or videos.
- We are committed to providing quick and professional solutions, no matter the size of the issue, to ensure your satisfaction.

Thank you for your trust and support! We hope you enjoy using our product!

HELP CENTER

Thank you for choosing us to be a part of your life. We value your business, and constantly strive to provide you only top-quality products and services. Contact us if we can be of further assistance, we'd love to hear your advice.

————— **Email: service@grandtunnel.com** —————



PRODUCT WARRANTY INFORMATION

Any damaged part during shipment or missing parts, please feel free to contact us via amazon or our support mail at: **service@grandtunnel.com**

It's our responsibility to send the replacement to the customer.

Pictures must be required for all returns to ensure an item is not damaged prior to its return. Any unboxed package will be considered a used product.

For the used item (once opened), we may charge return and restocking fee according to item's condition. The restocking fee will be charged up to 50% of the item's price for the used or damaged item, and up to 100% for materially different items.

For the unopened package, all items can be returned for any reason within 30 days of the receipt and will receive a full refund back to the original payment method.

All returns must be shipped back to our warehouse, the refund will be issued after received by warehouse staff. Boxes for return shipping will not be provided by us and is the customer's responsibility to either use the original shipping boxes.

WARNING

Manufacturer and seller expressly disclaim any and all liability for personal injury, property damage, or loss, whether direct, indirect, or incidental, resulting from the incorrect attachment, improper use, inadequate maintenance, or neglect of this product.