







ASSEMBLY INSTRUCTIONS

Thank you for purchasing this quality product. Be sure to check all packing material carefully for small parts that may have come loose inside the carton during shipment.

Hardware kit			
No		Description	Q'Ty
A		Hex Nut Ø8	4 pcs
B		Lock Washer Ø8	11 pcs
C		Flat Washer Ø8	11 pcs
D		Long Bolt Ø6 x 80mm	4 pcs
E		Short Bolt Ø6 x 40mm	3 pcs
F		Allen Key	1 pc
G		Key Wrench	1 pc

Key Parts		
No	Description	Q'Ty
1	Chair Back	1 pc
2	Complete Seat	1 pc
3	Front Leg	2 pcs
4	Floor glide	4 pcs

STEP 1

- Carefully lay Chair Back on a smooth flat surface to prevent scratches.
- Attach Complete Seat to Chair Back by inserting a Flat Washer (C), Lock Washer (B) with Short Bolt (E) into each of the hole on the back rail of the seat, and Long Bolt (D), Lock Washer (B) and Flat Washer (C) into each of 2 holes in the Seat corners. (See Detail A & B).
- Tighten screws with provided Allen Key (F) by turning clockwise until secure

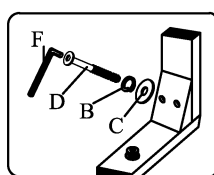

DETAIL B

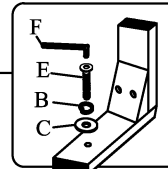
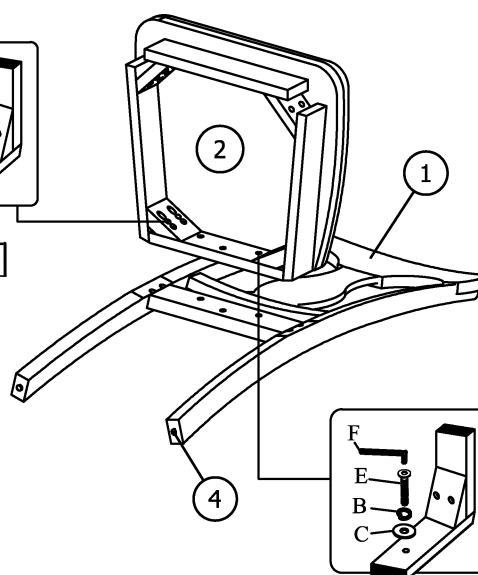

DETAIL A

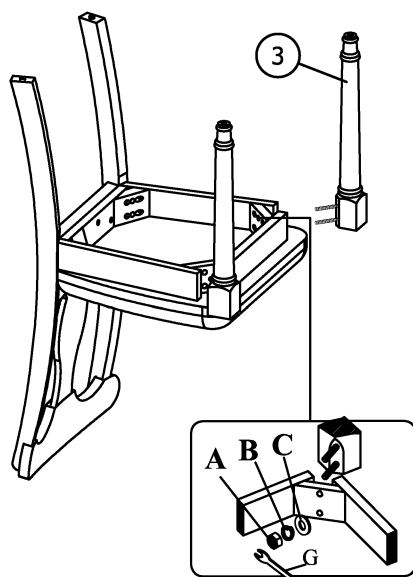

DETAIL C

STEP 2

- Carefully turn Chair upside down and attach each Leg to the front corners of the Complete Seat.
- Place Flat Washer (C), Lock Washer (B) and Nut (A) on for each bolt, tighten nuts using provided Key Wrench (G).

