

8ft. Customized Black Closet Organizer System

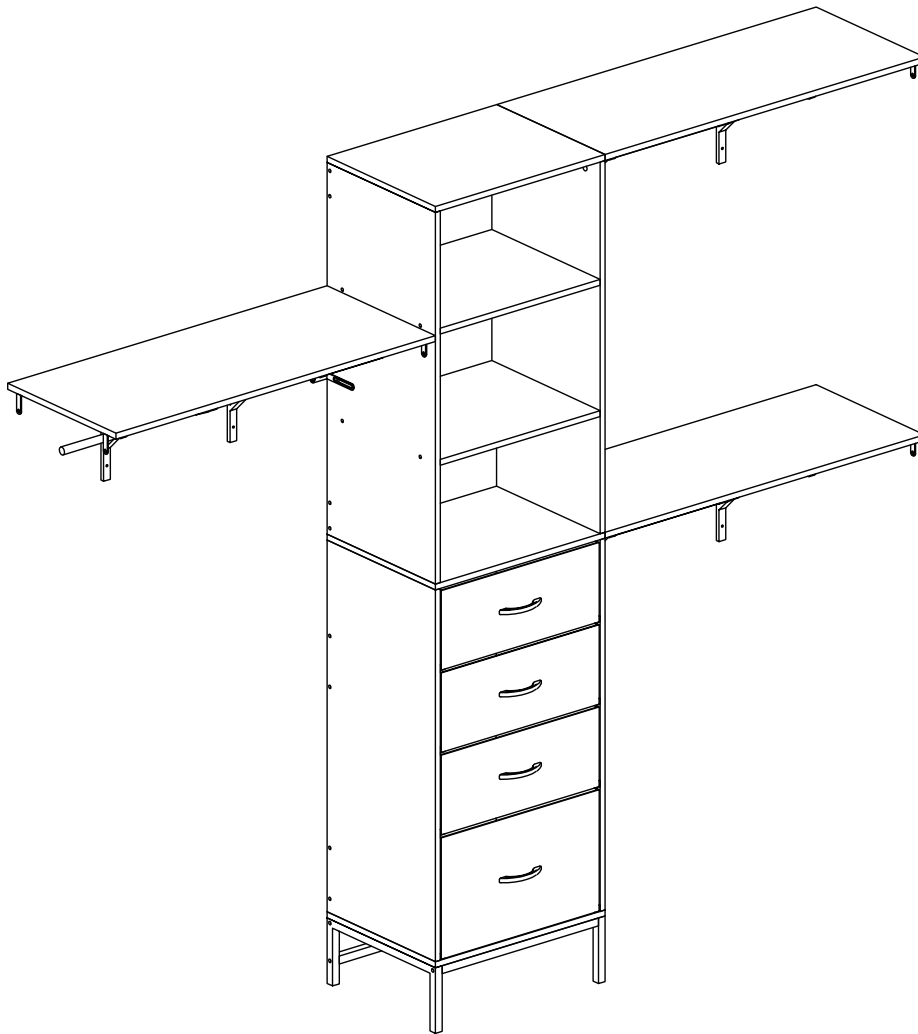

After-sales mailbox:
Homefurnitureserviceteam@outlook.com

NOTICE

Please keep these instructions for future reference.

Dear Customer

● Thank you for your purchase. When you receive the product, please make sure that all the parts are intact. If any parts are missing, please contact us promptly to request replacement parts.

● Then follow the entire installation instructions to install.

● Each part is crucial, so please be careful not to lose any. It is recommended to store parts with different lettered identifiers in separate boxes or bags to avoid confusion during installation.

A . The outer box is damaged

B . The product is damaged / bent / cracked while you open the box

C . The parts / accessories / assembly tools are missing

D . The instructions are not clear and can not be referred

E . The product has functional problems









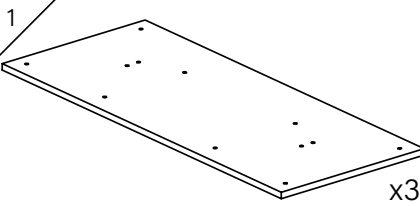
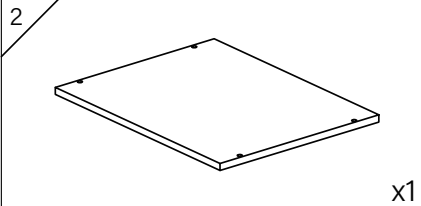
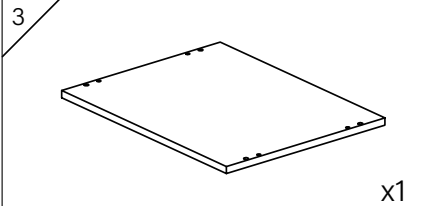
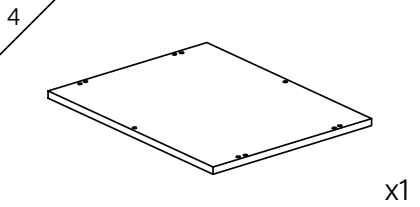
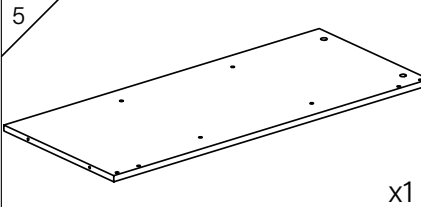
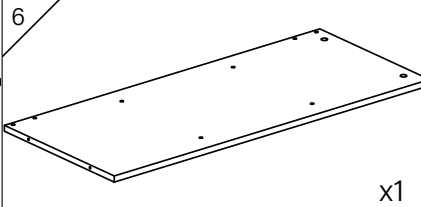
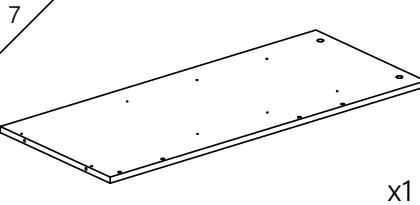
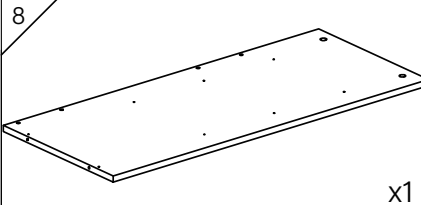
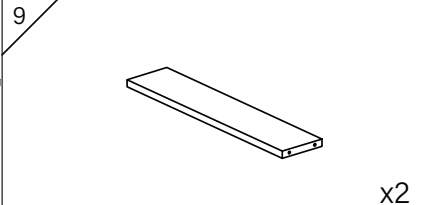
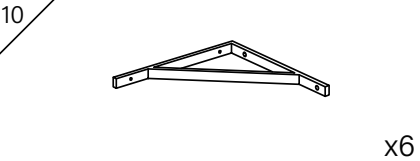
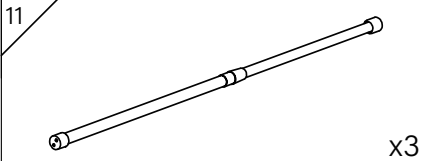
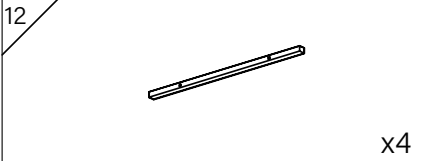
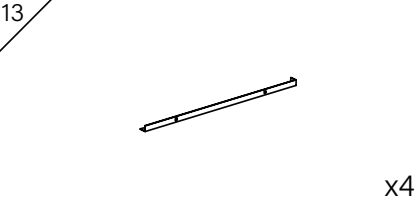
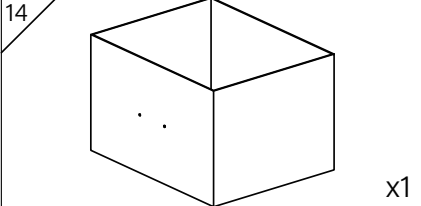
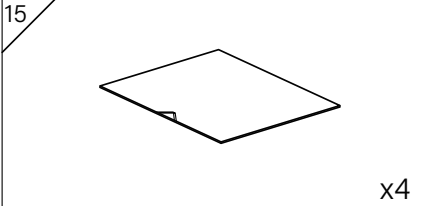
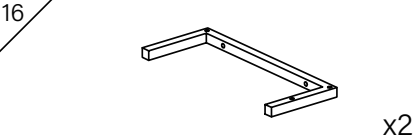
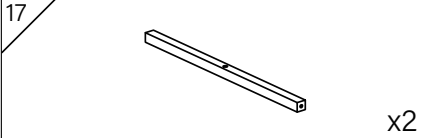
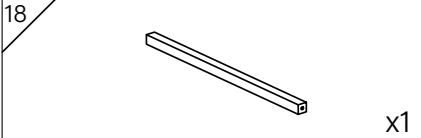
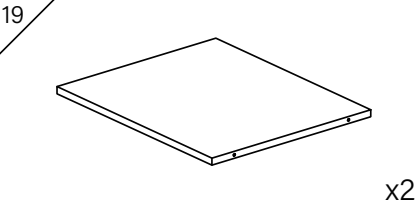
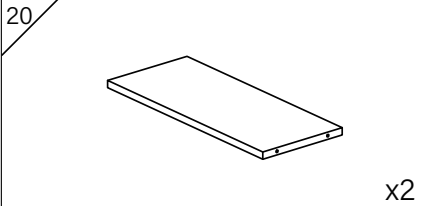
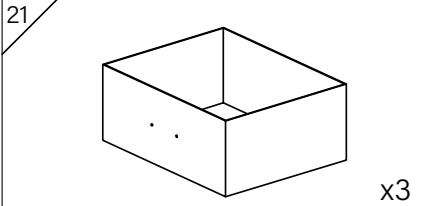
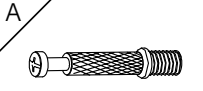

F . Other aspects that you are not satisfied with

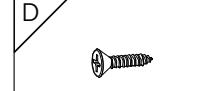
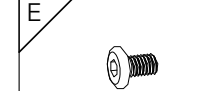
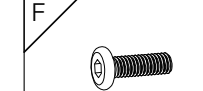
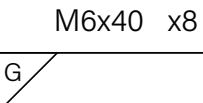
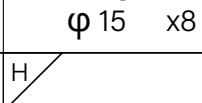
Please feel free to contact us for help. Our after-sales team service

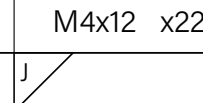
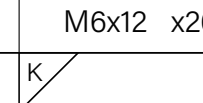
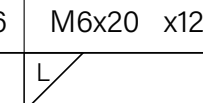
(Homefurniture Serviceteam@outlook.com) will reply within 24 hours and will do our best to resolve the problem for you.

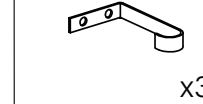

PART LIST

1  x3	2  x1	3  x1			
4  x1	5  x1	6  x1			
7  x1	8  x1	9  x2			
10  x6	11  x3	12  x4			
13  x4	14  x1	15  x4			
16  x2	17  x2	18  x1			
19  x2	20  x2	21  x3			
A  M6x40 x8	B  $\varnothing 15$ x8	C  M4x7 x8	D  M4x12 x22	E  M6x12 x26	F  M6x20 x12
G  M6x30 x6	H  M6x50 x32	I  x4	J  x3	K  x14	L  M4x35 x26
M  x20	N  x14	O  M6x40 x6			

STEP

01

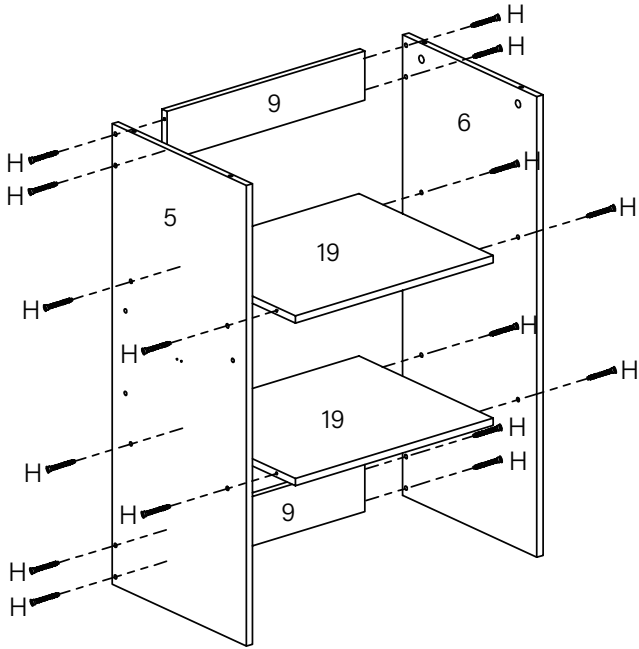

H x16

02

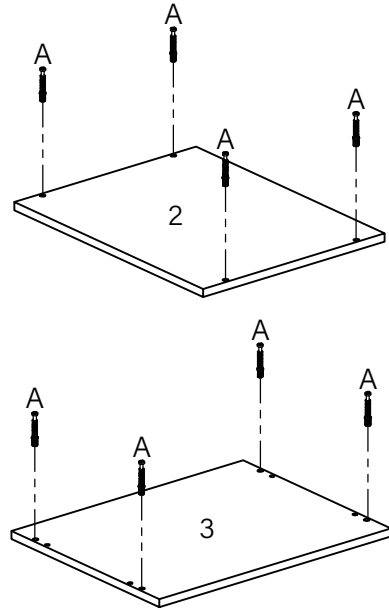

A x8

03

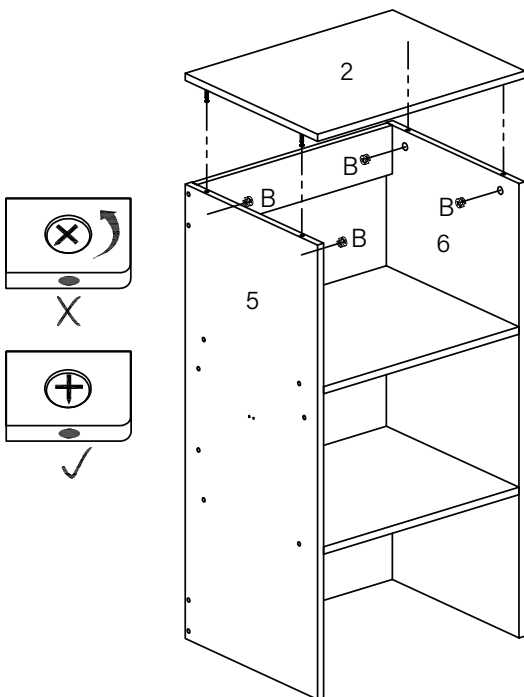

B x4

04

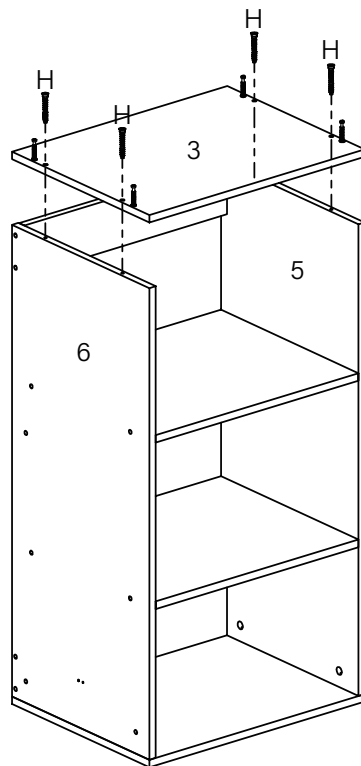

H x4

03

STEP

05

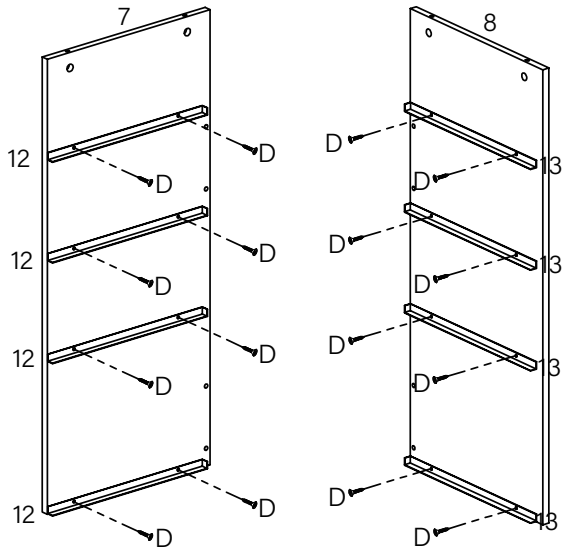

D x16

06

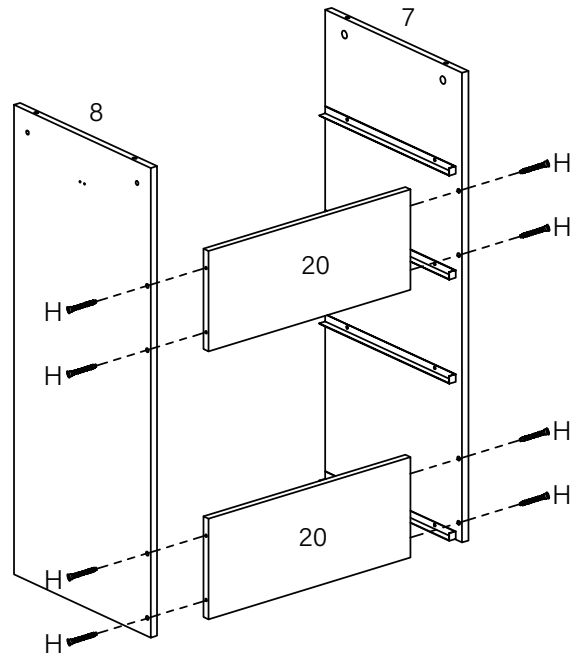

H x8

07

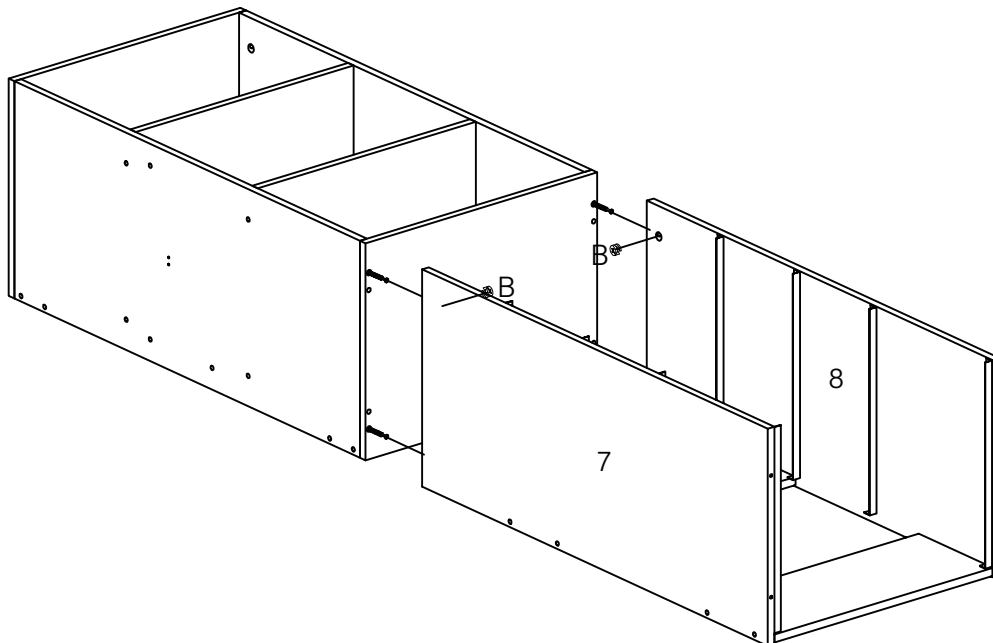

B x4

04

STEP

08

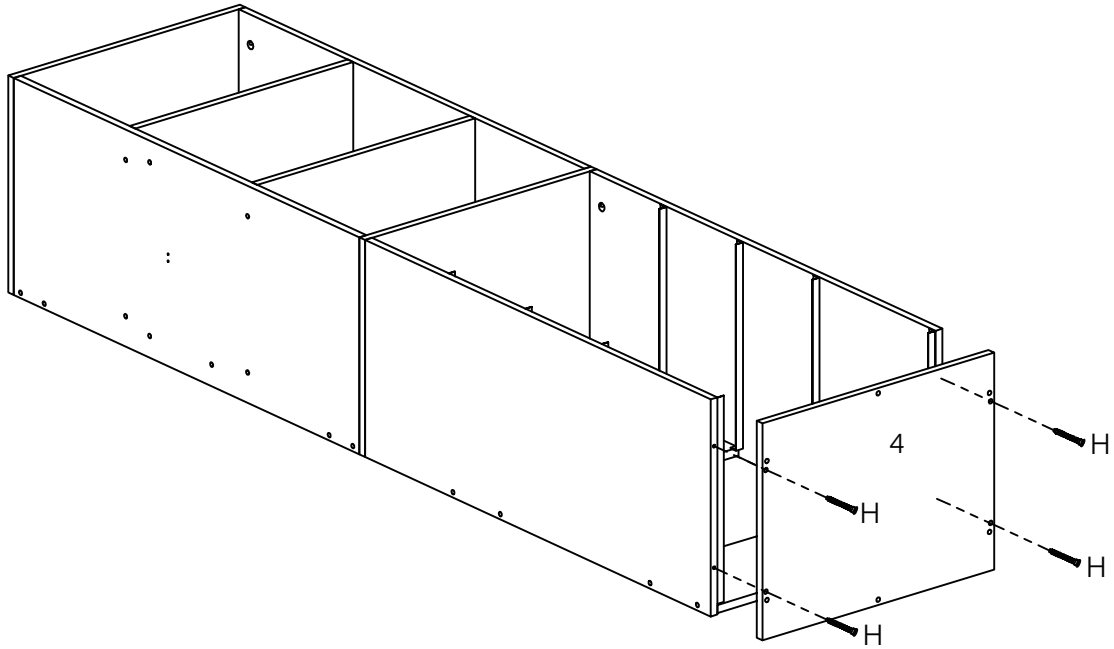

H x4

09

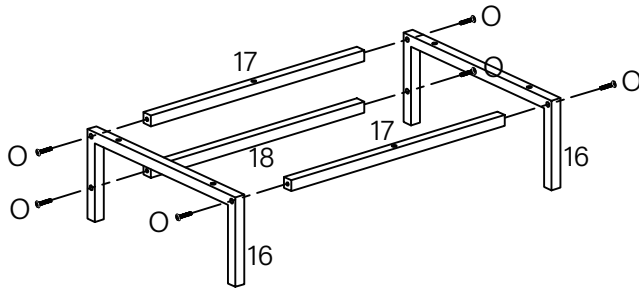

O x6

05

STEP

10

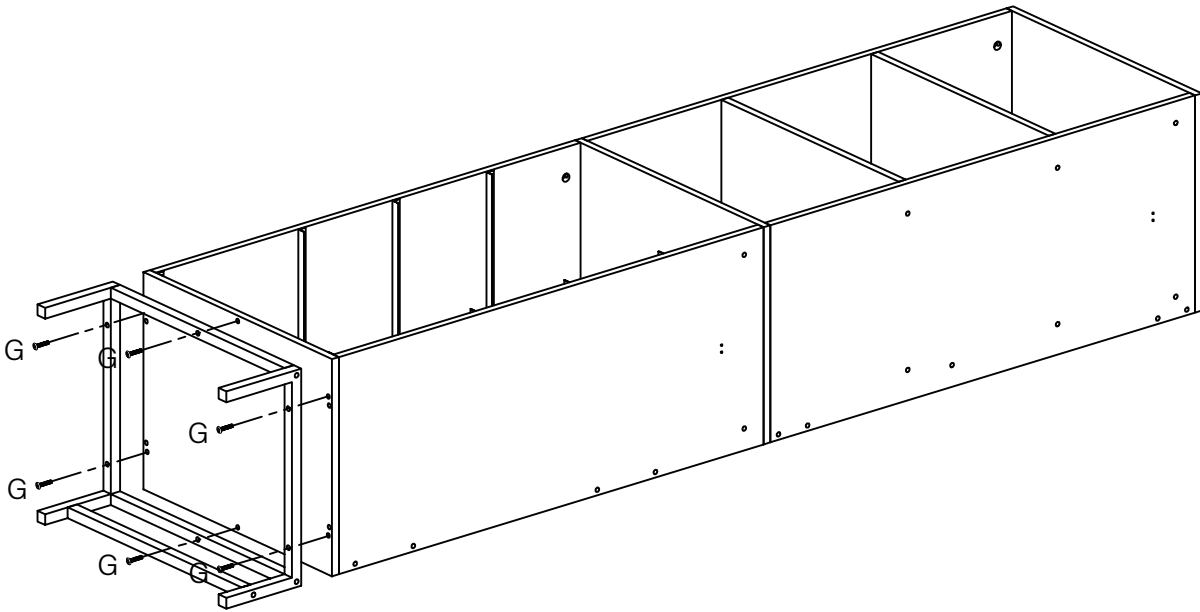

G	x6
---	----

11

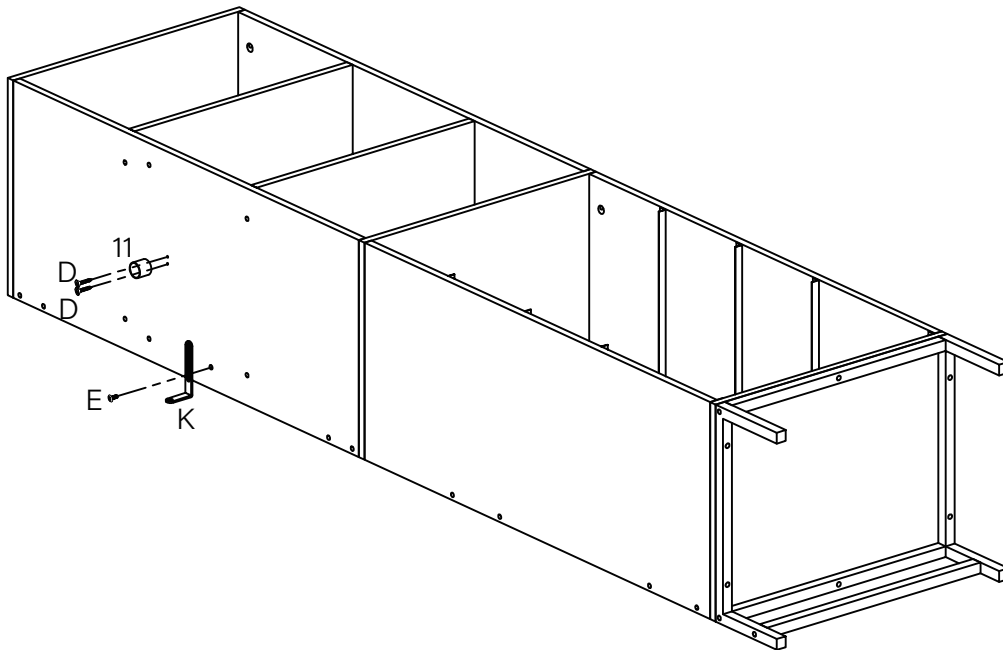

D	x2
E	x1
K	x1

STEP

12

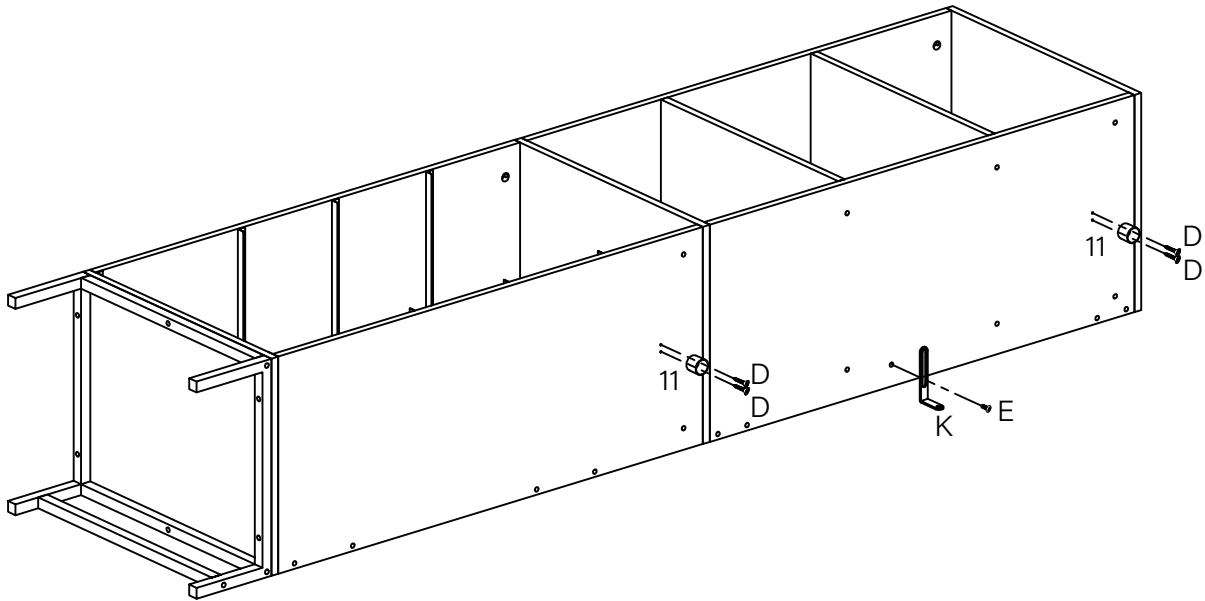

D	x4
E	x1
K	x1

13

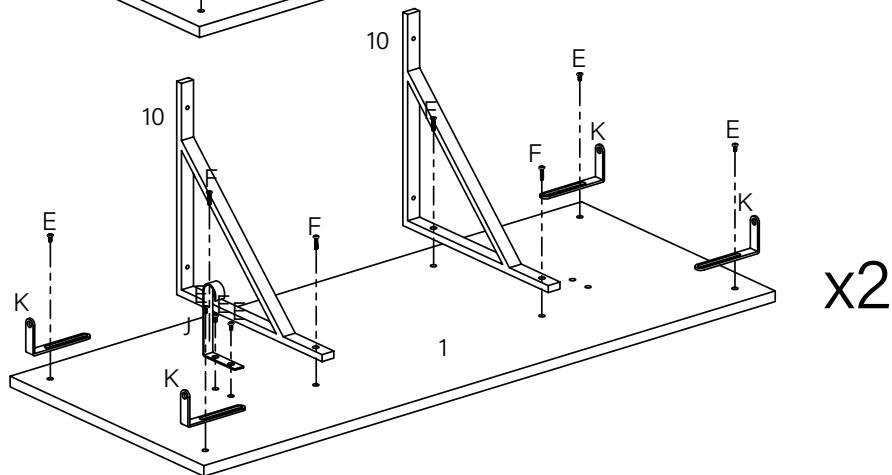
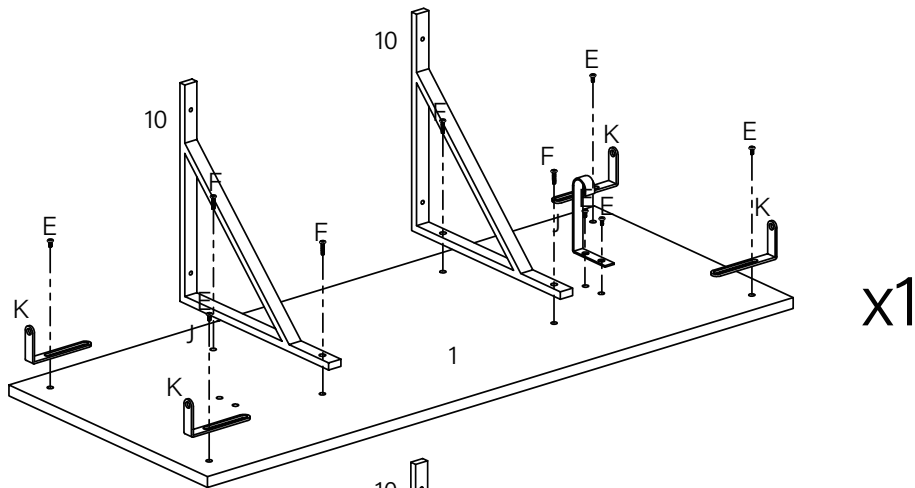

F	x12
J	x3
E	x18
K	x12

STEP

14

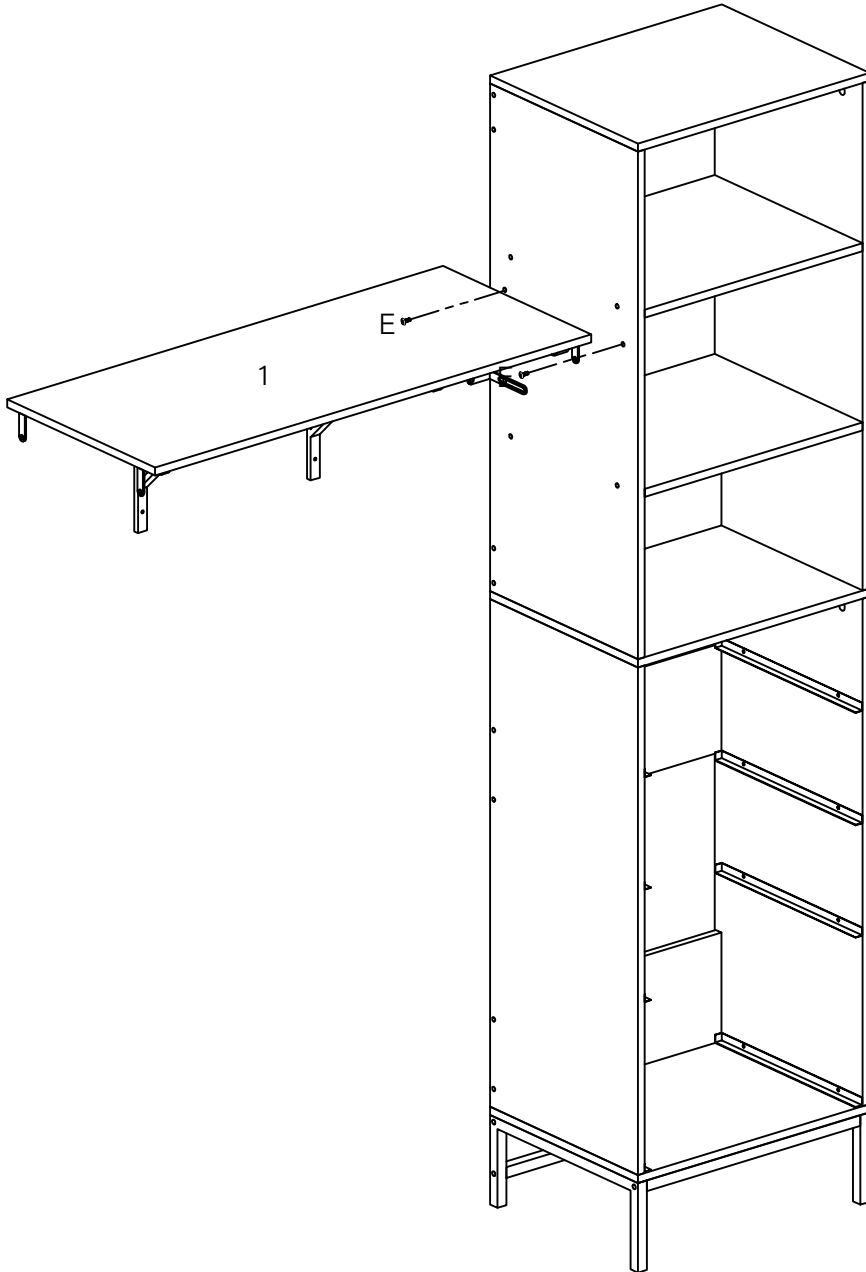

E	x2
---	----

STEP

15

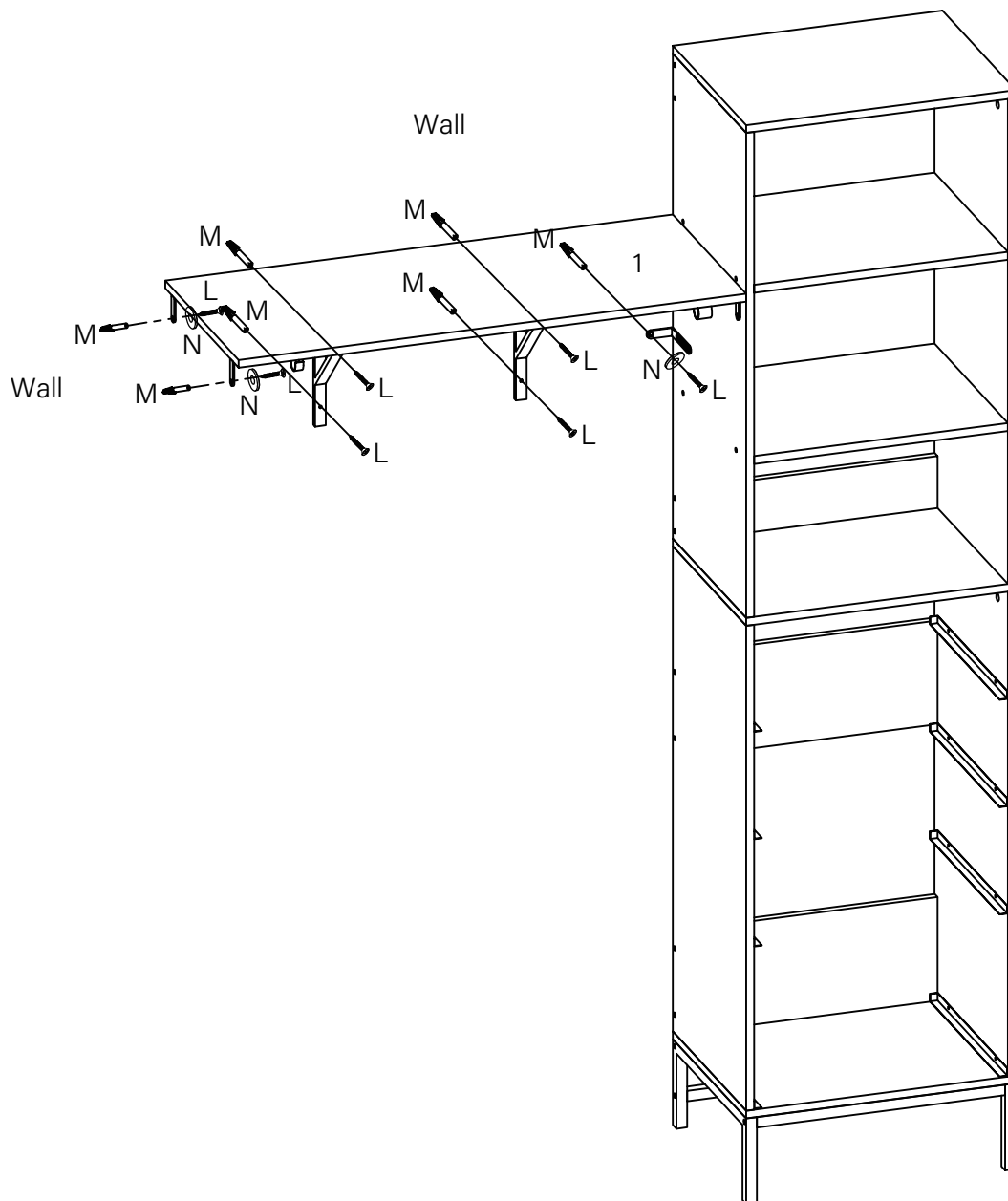

L	x7
M	x7
N	x3

STEP

16

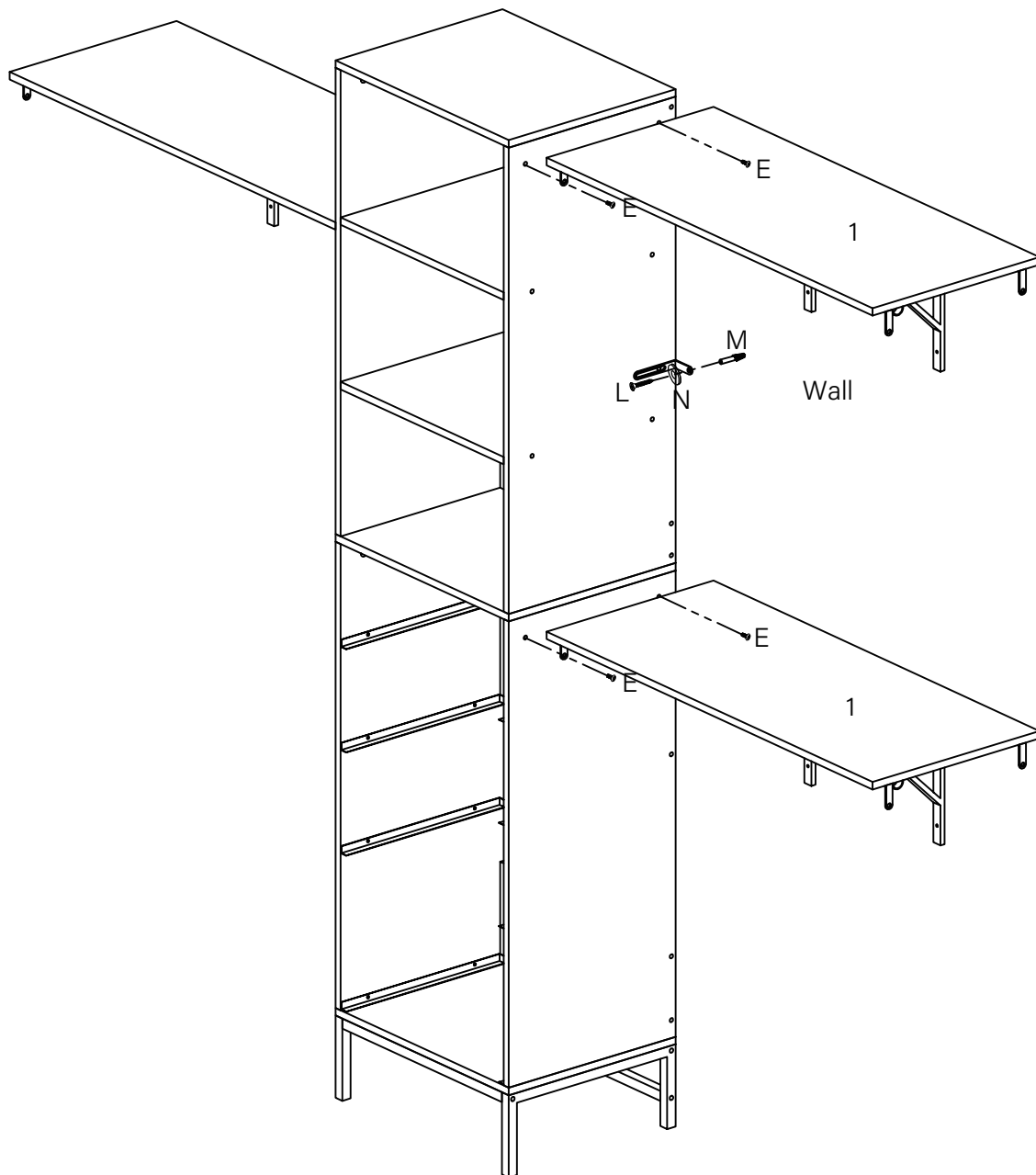

L	x1
M	x1
N	x1
E	x4

STEP

17

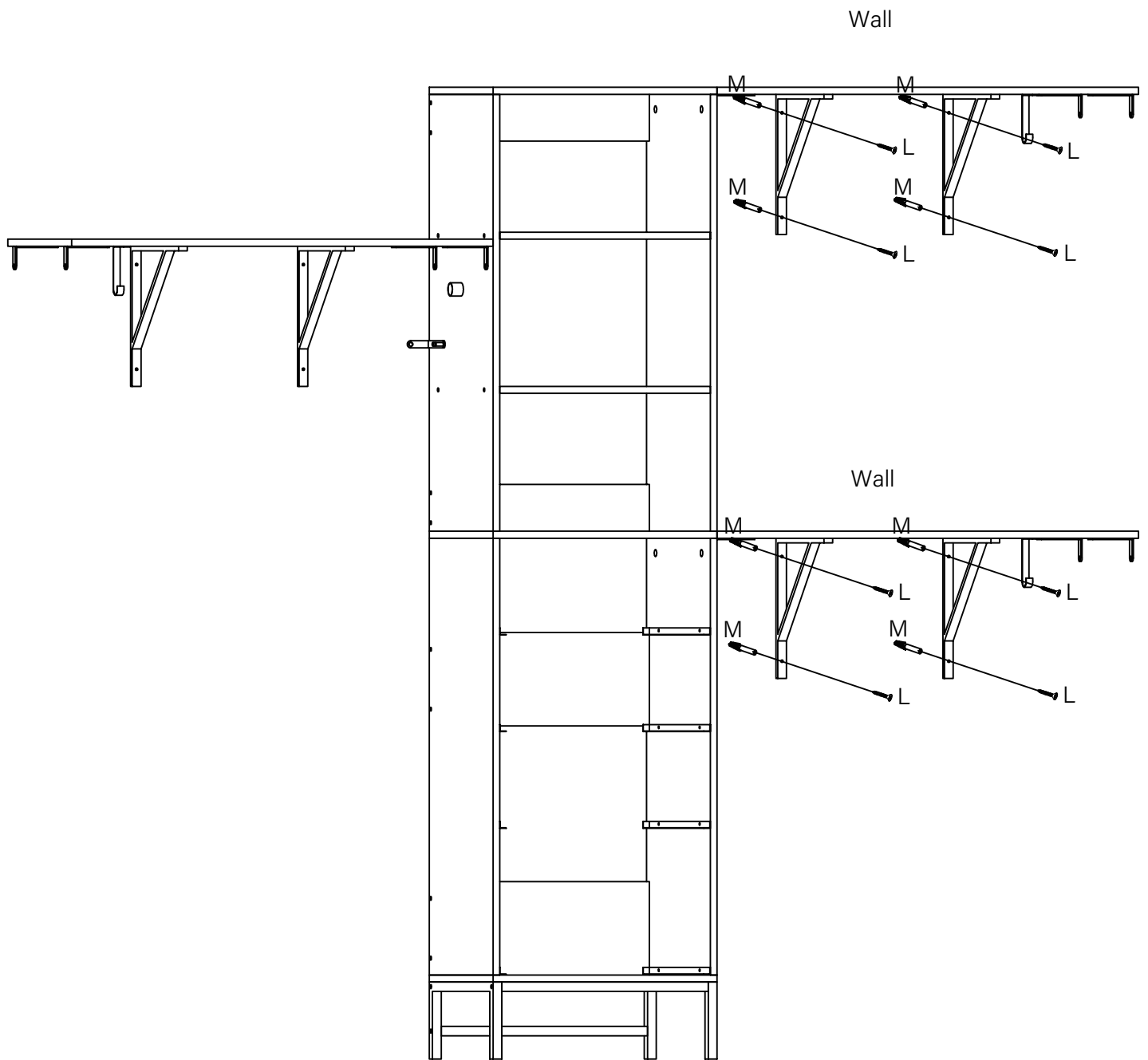

L	x8
M	x8

STEP

18

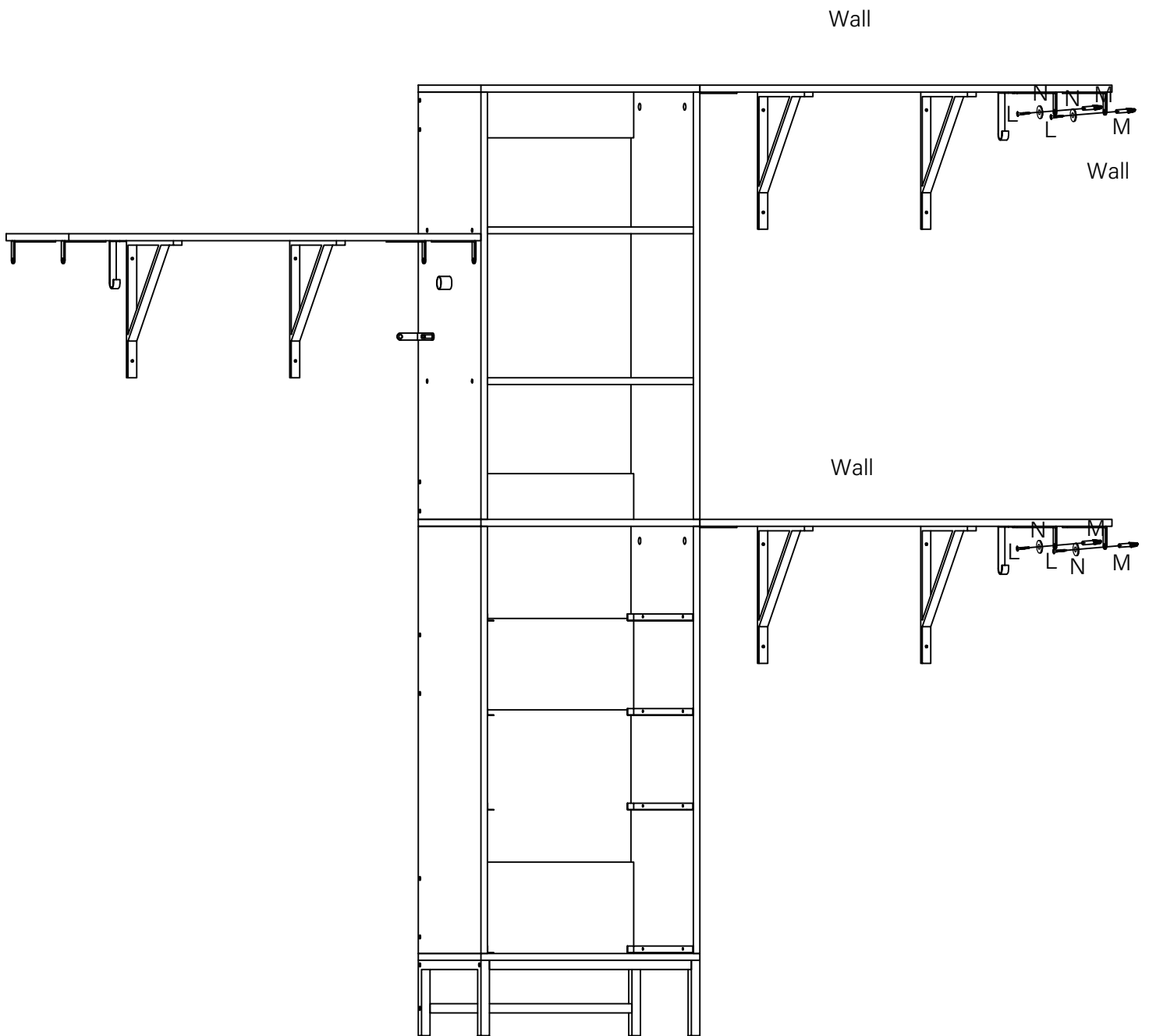

L	x4
M	x4
N	x4

STEP

19

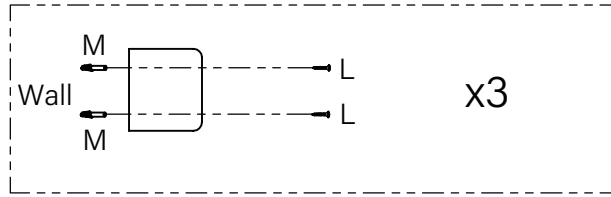

Wall

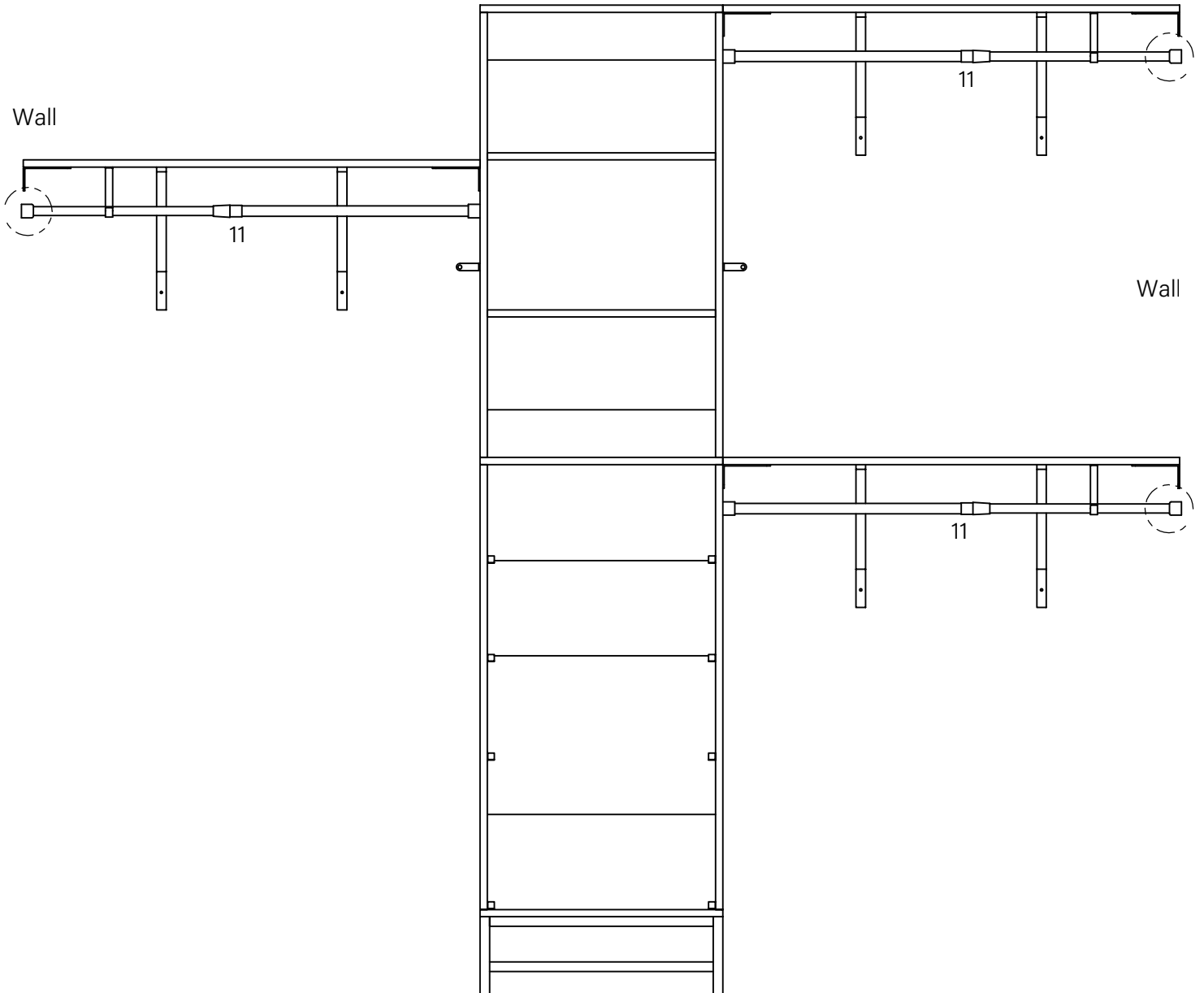

L	x6
M	x6

STEP

20

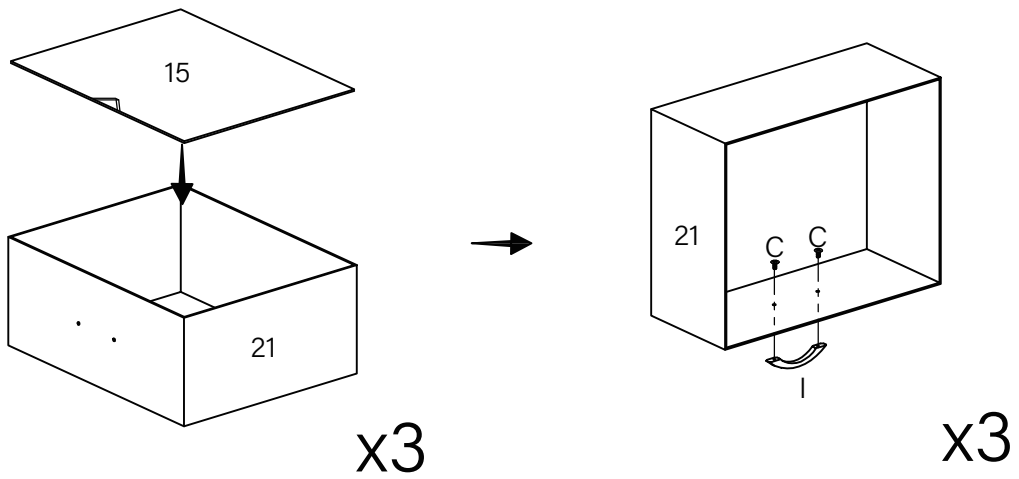
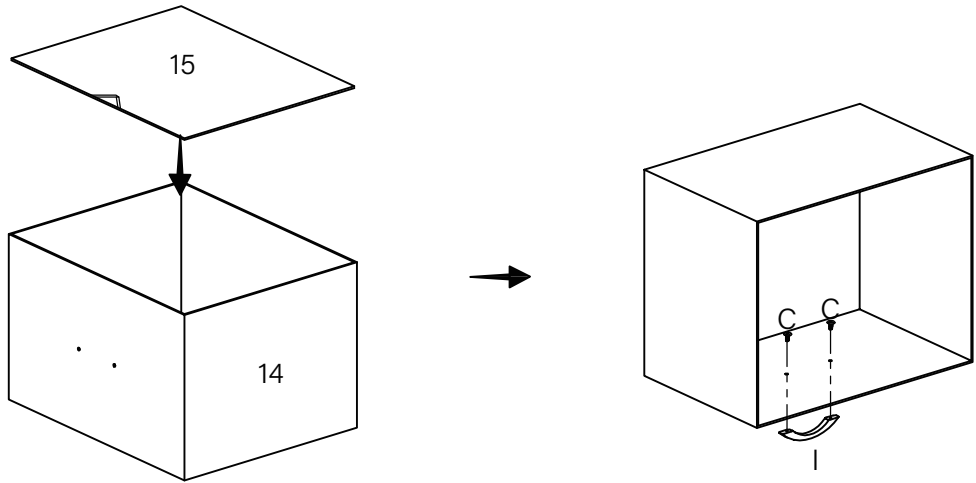

I	x4
C	x8

STEP

21

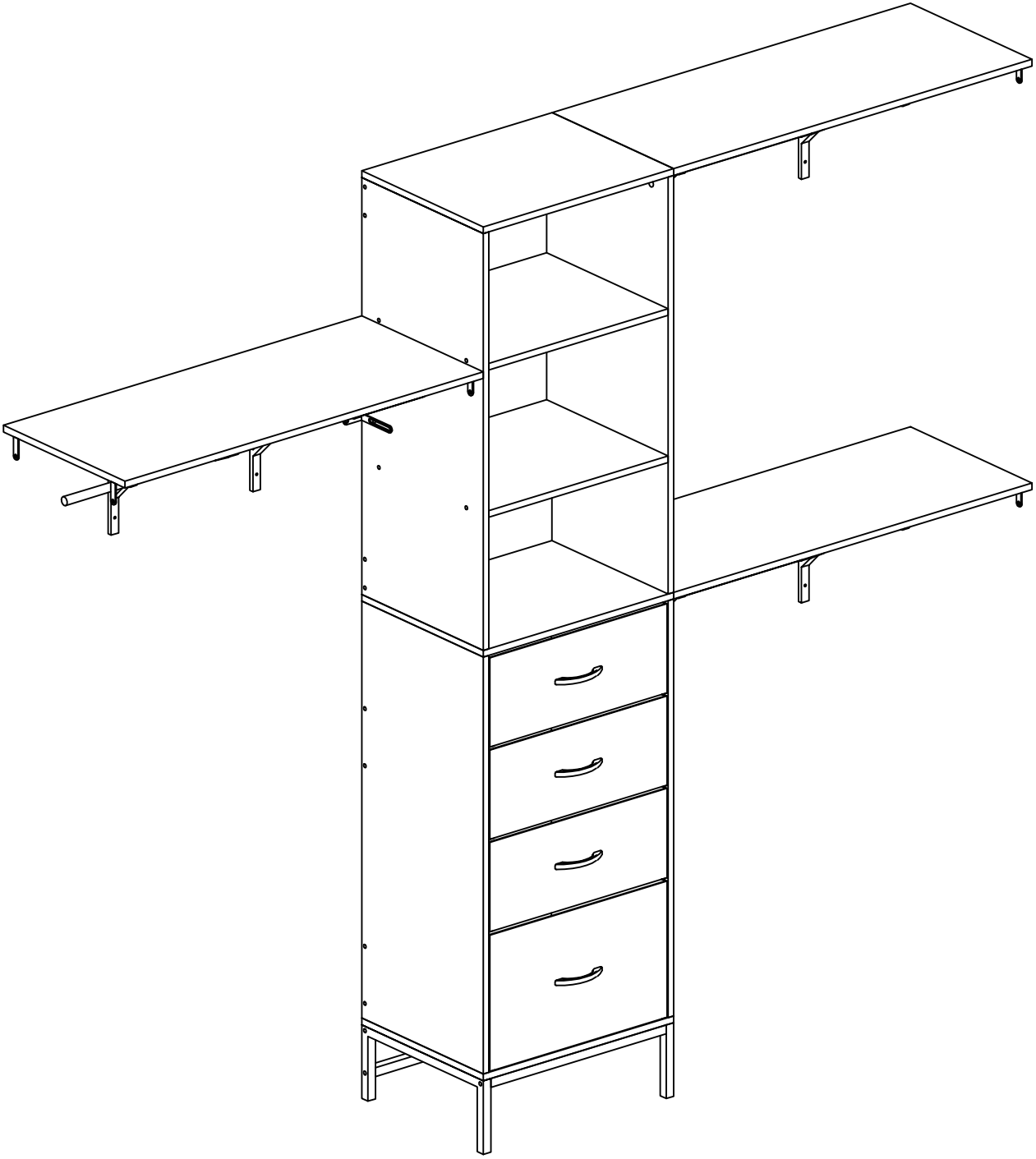

AFTER-SALE SERVICE

If you have any suggestions for our products or notice any quality issues, please contact us first. Our after-sales team will respond within 24 hours and will do everything possible to provide you with a satisfactory solution.

Guaranteed Customer Service

Your shopping experience is very important to us!
Feel unsatisfied? **Contact us!**
Have any questions? **Contact us!**

Wanna share how wonderful our smart products make your home?

Share your pictures with us.

Any suggestions? **Contact us!**

We will check and give feedback.



Homefurnitureserviceteam@outlook.com

