

# Instruction Manual

## 2.4m Square Premium LED Cantilever Parasol

[www.laura-james.co.uk](http://www.laura-james.co.uk)

1617664.11 / 1617657.11

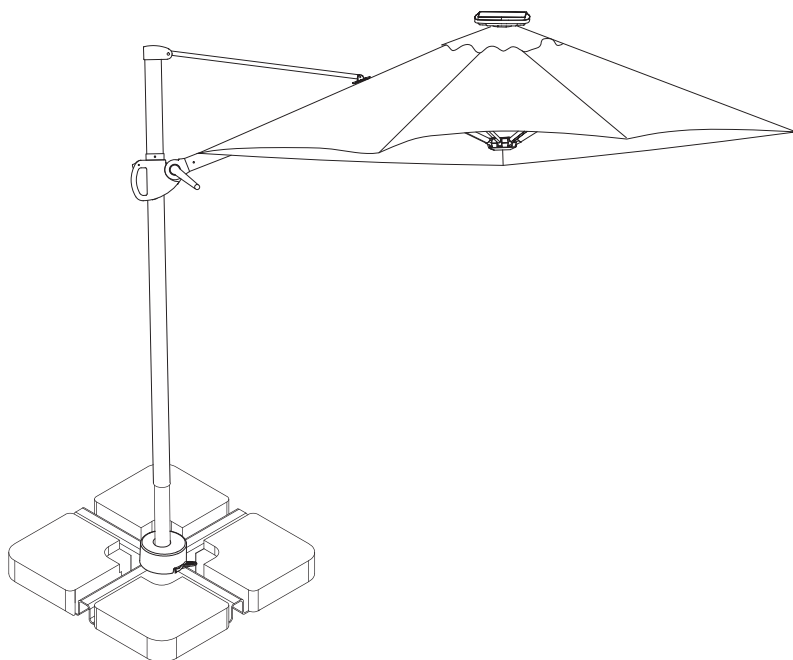

# CONTENTS

---

Safety and care advice	<b>1</b>
Components	<b>2</b>
Assembly instructions	<b>3</b>
Copyright	<b>12</b>

# ⚠ SAFETY AND CARE ADVICE ⚠

---

## PLEASE READ THESE INSTRUCTIONS CAREFULLY AND KEEP FOR FUTURE REFERENCE

- **Warning:** This unit weighs approximately 17.8 kgs. Please lift with care.
- Check you have all the components and tools listed on page 2.
- Remove all fittings from the plastic bags and separate them into their groups.
- Keep children and animals away from the work area, small parts could choke if swallowed.
- Make sure you have enough space to lay out the parts before starting.
- Do not stand or put weight on the product, this could cause damage.
- Assemble the item as close to its final position (in the same room) as possible.

- Assemble on a soft level surface to avoid damaging the unit or your floor (use opened out unit carton).



- We do not recommend the use of power drill/drivers **for inserting screws**, as this could damage the unit. Only use hand screwdrivers.
- Dispose of all packaging carefully and responsibly.

## CARE AND MAINTENANCE

---

- Only clean using a damp cloth and mild detergent, do not use bleach or abrasive cleaners.
- From time to time check that there are no loose screws on this unit.
- This product should not be discarded with household waste. Take to your local authority waste disposal center.

**Note** *If required the next page can be cut out and used as reference throughout the assembly. Keep this page with these instructions for future reference.*

- We strongly recommend that you store your parasol when not in use, especially during winter months.

We do not recommend leaving your parasol out in poor weather or unattended in furniture when a gust of wind could cause damage.

You should ensure your parasol is clean and dry to prevent any mould or mildew forming when folded and stored.

# COMPONENTS

Ensure the following components are in the box before proceeding with assembly:



**A** x1



Lower Cross Base

**B** x1



Upper Cross Base

**C** x1

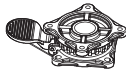

Rotate Bearing

**D** x1

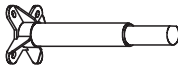

Central Spigot

**E** x1



Rotate Bearing Cover

**F** x1



Knob

**G** x1

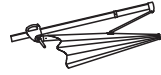

Main Frame and Canopy

**H** x1



Solar Panel

**I** x4



Bolt M10\*25mm

**J** x4



Bolt M10\*20mm

**K** x8



Washer M10

**L** x1



Allen Key



# ASSEMBLY INSTRUCTIONS

- Step 1** Place the upper cross base (B) over the Lower Cross Base (A).

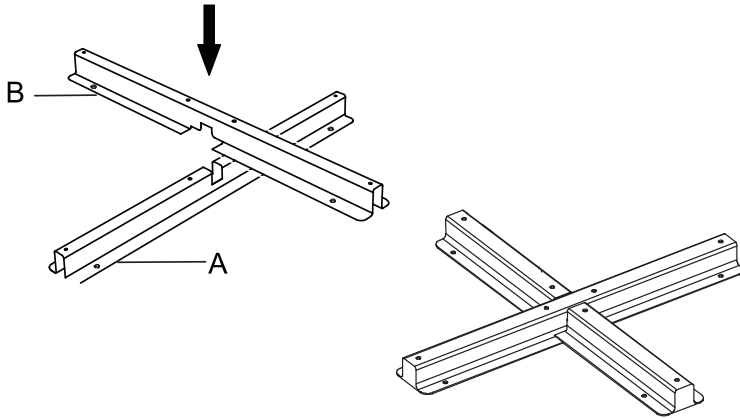

- Step 2** Using the Allen Key, fix the Rotate Bearing to the assembled Cross Base with 25mm Bolts and Washers. Tighten firmly.

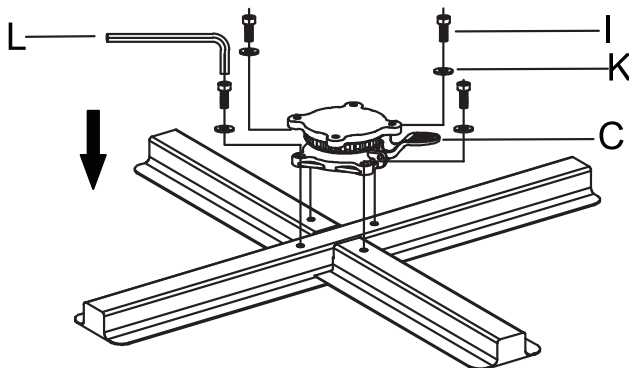

# ASSEMBLY INSTRUCTIONS

---

- Step 3** Using the Allen Key, fix the Central Spigot to the Rotate Bearing with 20mm Bolts and Washers. Tighten firmly. Place the plastic Rotate Bearing Cover over the Rotate Bearing.

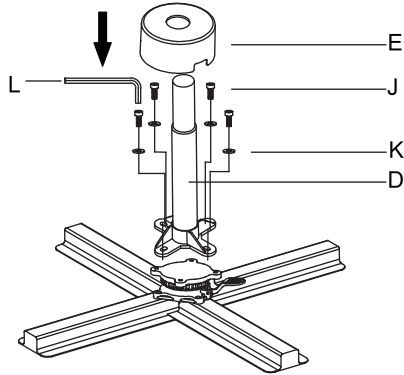

- Step 4**

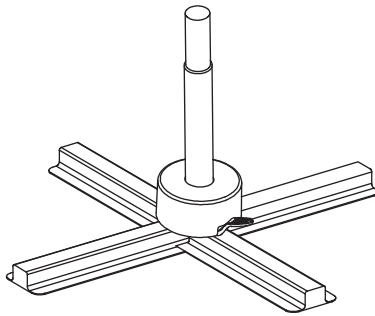

# ASSEMBLY INSTRUCTIONS

---

- Step 5** Locate the plug at the top of the umbrella. Carefully insert the plug into the socket located on the underside of the solar panel.

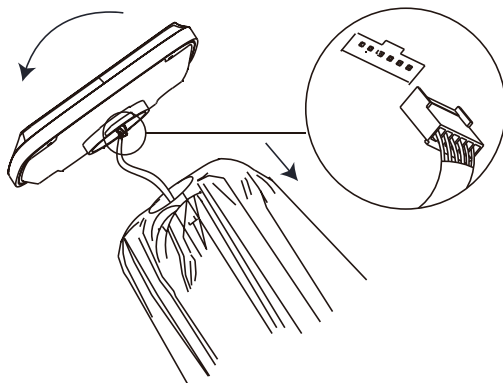

- Step 6** Place the solar panel on the top of the umbrella taking care to conceal the wires inside the gap at the top of the umbrella, then gently turn the solar panel in a clockwise direction to attach it to the umbrella. Take care not to over tighten as this may damage the umbrella and/or the solar panel.  
**Once the assembly is complete, please remove the protective plastic film on the solar panel, this film is used to prevent damage during shipment.**

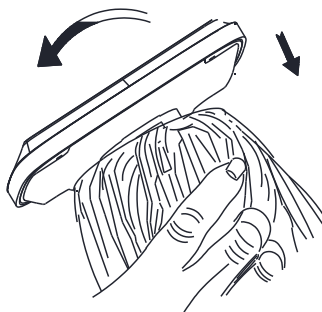

# ASSEMBLY INSTRUCTIONS

---

- Step 7** Place the Cross Base in your preferred location and follow the 'Cross Base Installation Tips' supplied on page 4.

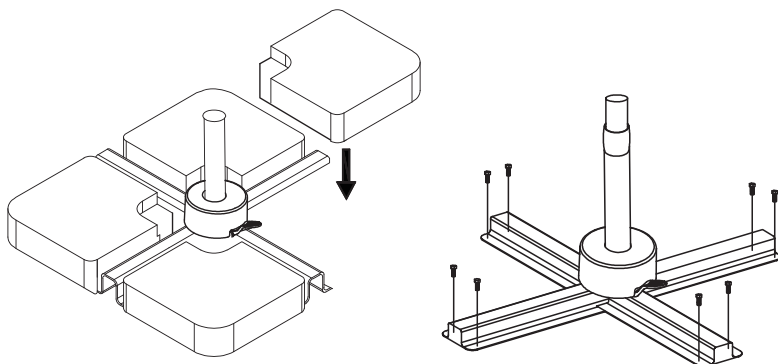

- Step 8** Attach the Main Frame and Canopy to the Central Spigot and fix using F

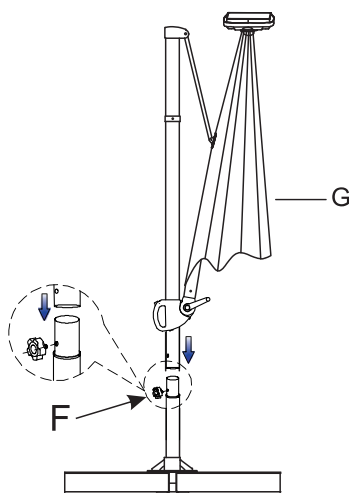

# OPERATING INSTRUCTIONS

---

- Step 1** Squeeze the trigger to unlock then slide the handle upwards until it is fully extended and stops.

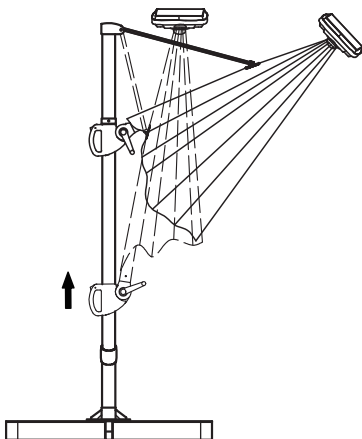

- Step 2** To open the umbrella turn the crank handle gently in a clockwise direction to open the umbrella canopy. Once the umbrella is fully open you can tilt the canopy angle by squeezing the trigger and releasing the button to set the canopy in the desired position. **The tilt option should only be used on days with NO WIND, use of the tilt function in even a light breeze may damage the umbrella and is not recommended.**

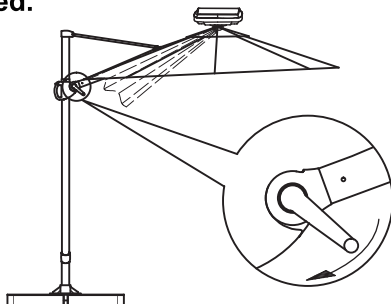

# OPERATING INSTRUCTIONS

**Step 3** The umbrella is able to rotate up to 360 degrees by pressing down the locking mechanism (as shown). To fix the umbrella at a desired position, simply release the lock.

**NOTE: Periodically, you must use a lubricant on the rotate bearing to prevent the loss of function of the locking mechanism.**

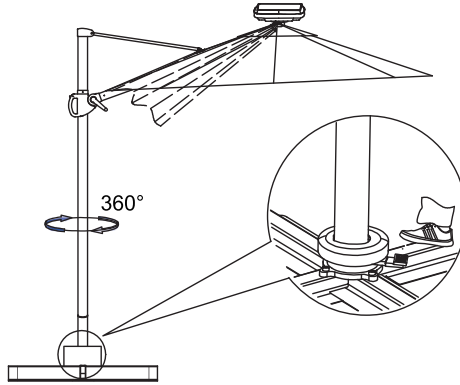

**Step 4** To close the umbrella, first bring the canopy back to a horizontal position, then gently turn the crank handle in counter-clockwise direction until the canopy is fully closed. Squeeze the trigger to unlock then slide the handle downwards until it is fully closed and stops. Secure the canopy to the pole using the Velcro strap provided.

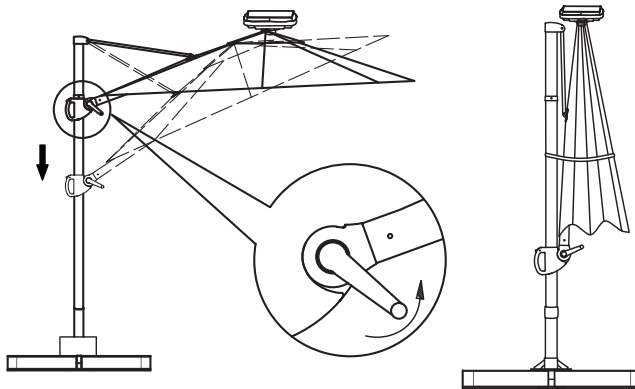

# OPERATING INSTRUCTIONS

---

## Step 5 Charging the battery:

Always place the solar panel in direct sunlight to charge the battery.

**IMPORTANT NOTE:** Please ensure the battery is charged for at least 8 hours in direct sunlight before first use, failing to follow this step may shorten the lifespan of the re-chargeable battery and decrease the performance of the lights. Make sure both the switches on the rib are always set to the “OFF” ‘O’ position during charging.

## Operating the lights:

To operate the lights, turn the switches (located on the end of one rib) to the ON ‘I’ position. Ensure the switches are in the OFF ‘O’ position when not using the lights.

**CAUTION:** If the lights are left on during the day the battery will NOT charge.

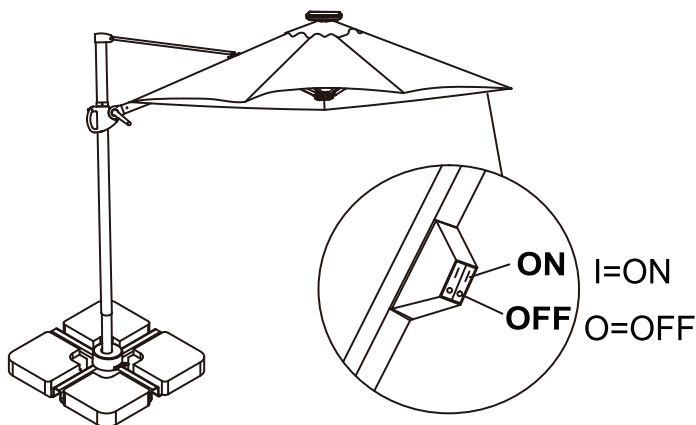

# REPLACING THE BATTERY

---

We recommend that you replace the battery in your solar umbrella once every year (or when you feel that the light is fading more quickly). You can purchase a replacement battery at specialty retailers. You will need 1 piece 18650 Lithium 2000mAh rechargeable battery which is the same as supplied from new.

**Failure to insert battery in the correct polarity, as indicated in the battery compartment may shorten the life of the battery or cause the battery to leak. Do not dispose of battery in fire. Battery should be recycled or disposed of as per state and local guidelines. Do not mix old and new batteries. Do not mix Alkaline, Standard (Carbon-Zinc) or rechargeable (Nickel Cadmium) or (Nickel Metal Hydride) batteries.**

- Step 1** Twist the solar panel counter clockwise and remove it from the top of the umbrella.

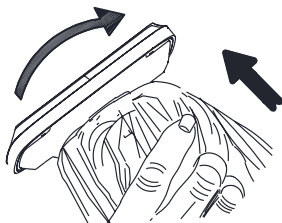

- Step 2** Carefully pull the plug out of the socket under the solar panel.  
**IMPORTANT: Do not pull the wire to remove the plug.**

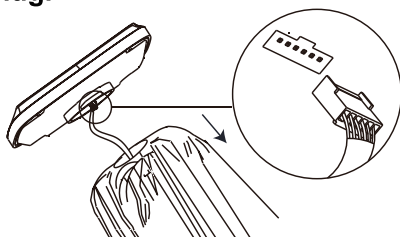

# REPLACING THE BATTERY

---

## Step 3

Place the solar panel on a flat surface, then open the battery cover as shown.

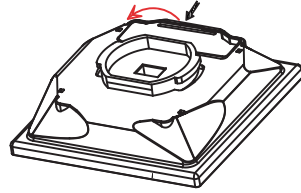

---

## Step 4

Carefully open the solar panel. Replace the batteries, matching the +/- on the battery with the +/- on the battery case.

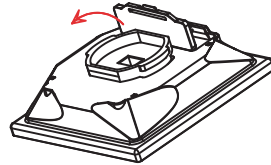

---

## Step 5

Please ensure the O ring is correctly located before replacing the cover.

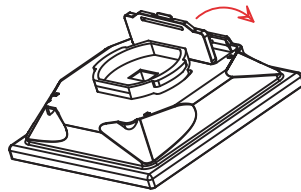

# OFFSET UMBRELLA BASE TIPS

---

## STANDARD INSTALLATION

- The cross base supplied with this offset umbrella requires 4 individual base weights at least 45lbs (20kg) each for a minimum combined weight of 180lbs (80kg) to provide the necessary support and stability. As a general rule the more weight the better the umbrella will be supported.
- Failing to use the minimum base weight will damage the umbrella and may also cause personal injury.

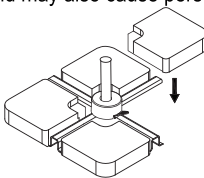

## SPECIAL INSTALLATION

- If you have a suitable timber deck, the cross base can be secured to it using 2" (5cm) M8 coach bolts or deck screws (not supplied). Ensure the fixing points are made into joists or bearers not just the decking boards. If using this option, extreme care must be taken to ensure the umbrella is never opened or used in wind greater than 5mph (8kph).

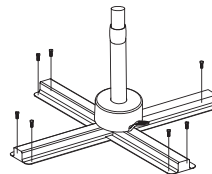

## IF YOU FIND A DEFECTIVE PART

---

We fully stock all parts and components. Any defective part can be quickly replaced. Take note of the defective part number in manual and we will arrange a replacement.

You can email our team at [customercare@laura-james.co.uk](mailto:customercare@laura-james.co.uk)

## COPYRIGHT

---

All material in this instruction manual is copyrighted by AGTC Ltd.

Any unauthorised use may violate worldwide copyright, trademark and other laws.

Thank you for purchasing!

Laura James® is a registered trademark of AGTC Ltd.  
Made in China for AGTC LTD S35 9ZX

---

Laura James

[www.laura-james.co.uk](http://www.laura-james.co.uk)