

SPECIFICATIONS

**CANTINA PRO**

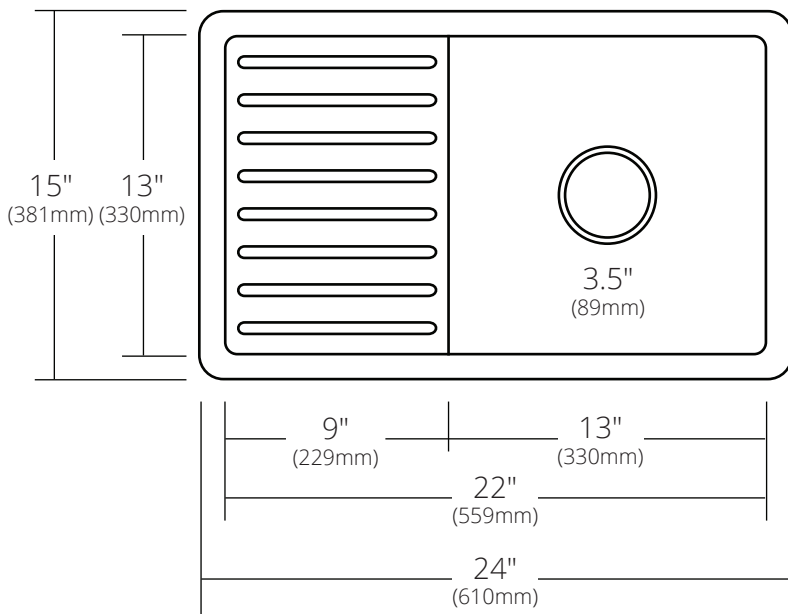

TOP VIEW



SIDE VIEW

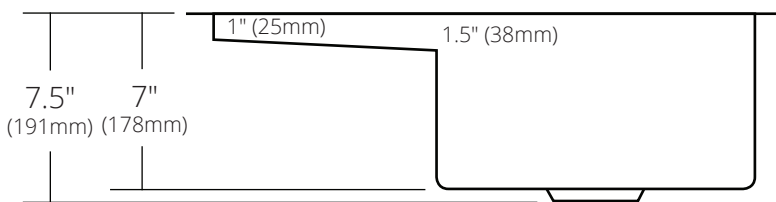

CPS233 Antique  
CPS533 Brushed Nickel

**PRODUCT DETAILS**

- 24" x 15" x 7.5" OD (610mm x 381mm x 191mm)
- Basin: 13" x 13" x 7" ID (330mm x 330mm x 178mm)
- Hand hammered 17 gauge recycled copper
- 3.5" (89mm) drain opening

**INSTALLATION**

- Undermount

**COORDINATING PRODUCTS**

- Drains: DR320 or DR340
- Bottom Grid: GR934

**STANDARDS COMPLIANCE**

- UPC/cUPC compliant

**IMPORTANT**

Due to the handcrafted nature of this product, it will vary in finish, texture, hammering, and other details. Dimensions may vary up to ¼" (6mm). We strongly recommend waiting for the actual product before making any installation cuts.