

G

M4x8
2 x SG1

3,5x15
6 x SP1

3 x
GL22

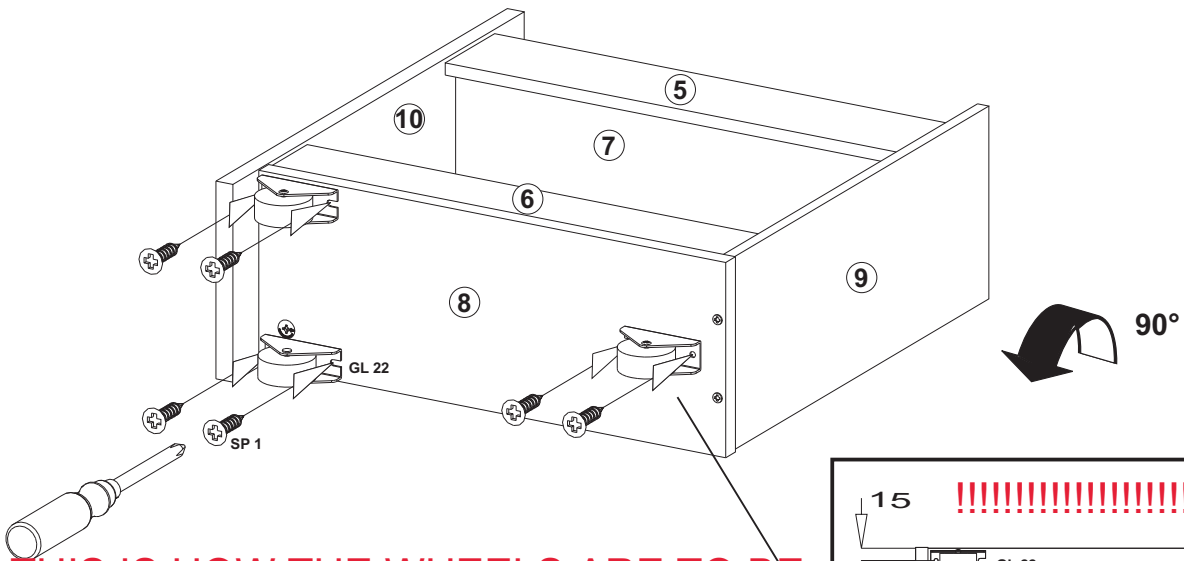

THIS IS HOW THE WHEELS ARE TO BE FIXED

