

**EXECUTIVE CHAIR
INSTRUCTION MANUAL**

ASSEMBLY INSTRUCTIONS

- Our clear, easy-to-follow, step-by-step instructions will guide you.
- Do not skip any steps. It is of utmost importance to assemble all of the parts according to the directions.
- Item identification: For ease of identification, all parts are labelled to correspond to the step number in which the part is used.

IMPORTANT

- Read the following instructions carefully before using the chair.
- Be aware that some parts are heavy and have sharp edges.
- Do not overtighten screws (insert all screws before tightening screws).
- Firmly secure all bolts , screws and nuts before use.
- Please do not exceed the weight limitations of this item.
- Reconfirm that all bolts , screws , and nuts are secure every 90 days.











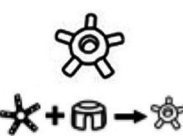





CARE & SAFETY

- Always use on firm level ground.
- Keep all children and pets away from the assembly area. Children and pets should be supervised while the product is being assembled.
- Vacuuming picks up dust and reduces the need for professional cleaning.
- In case of fire, do not attempt to extinguish any burning polypro-pyleneene with water.
- Be very careful when assembling chairs to avoid smashing your hands or fingers.
- Please contact Customer Service if you have any problems or discover any missing parts.

MAINTENANCE

- Wash the surface with a soft cloth soaked in mild detergent and warm water. Pay attention to drying the water in time. Do not use solvents or abrasive kitchen cleaners.
- Vacuum fabric as needed using an upholstery attachment.
- Do not use or store this item in the proximity of open flame or flammable/combustible chemicals.
- Do not brush fabric or use a vacuum attachment with a rotary brush.
- Brushing may permanently damage the nap or change the character of the fabric.

Accessories List

(A) 5 Castors 	(B) Central Base 	(C) 5 Base Tube 	(D) Air Rod 	(E) Base Plate 	(F) Seat Cushion 
(G) Backrest 	(H) Armrest Pad 	(I) Armrest Frame 	(J) Steel Plate 	(K) Cushion 	(L) Footrest Cushion 
(M) 18 Screws  M6*20mm	(N) 8 Screws  M6*25mm	(O) 4 Screws  M6*30mm	(P) 3 Screws  M8*20mm	(Q) Hexagon Wrench 	

Assembly Instruction

Step 1

Insert 5 Base Tubes (C) into Central Base Tube (B), align with the holes and tighten 10 M6*20 screws (M).

Note: Please remove the central base buckle from the Central Base (B) first, then insert the Base Tube (C).

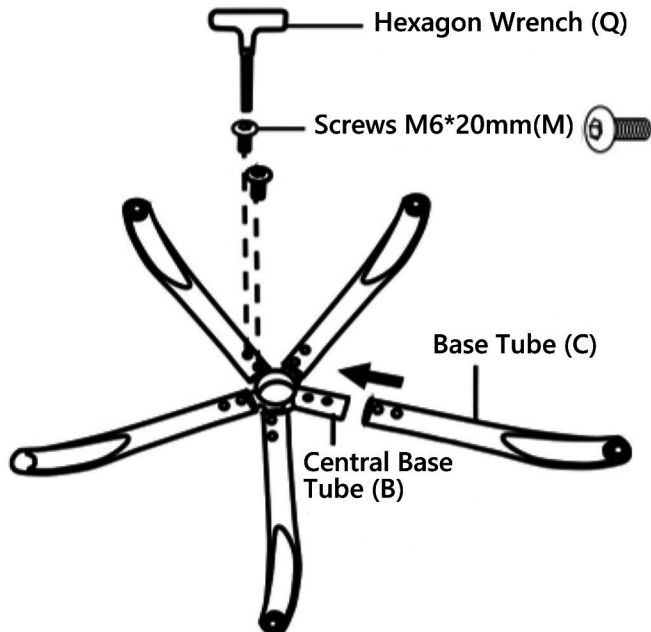
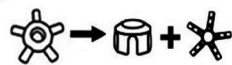

Step 2

Insert 5 Castors (A) into Base Tube (C), please make sure castors are securely installed before use.

Put Air Rod (D) through Central Base Tube (B) into the hole of Central Tube (B).

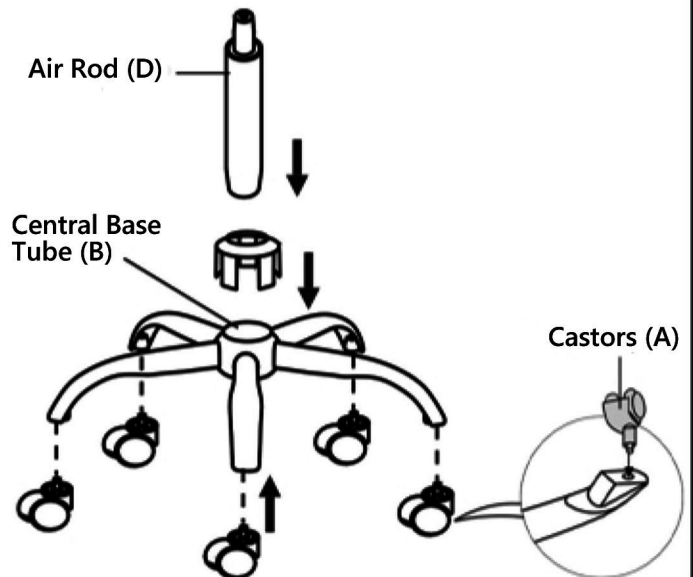

Step 3

Fix armrest pad (H) to armrest frame (I) with 4 M6*20 screws (M).

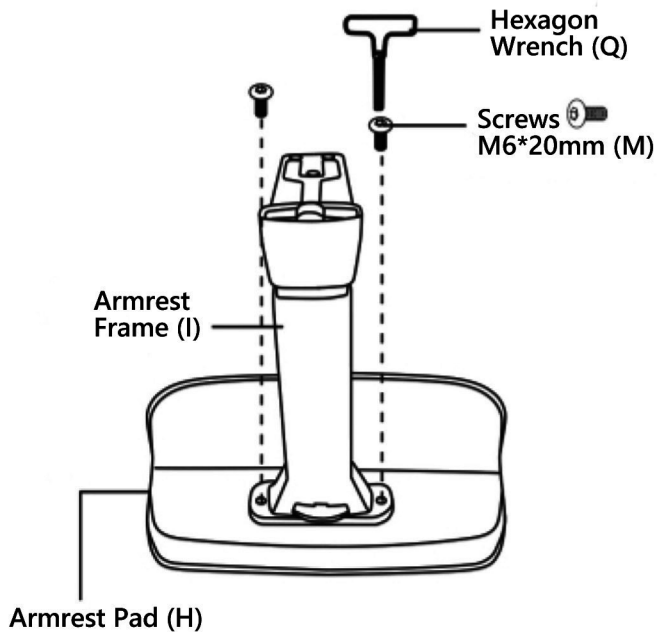

Step 4

Attach the base plate (E) to the seat cushion (F) with 4 M6*20 screws (M).

*As shown in figure, please make sure the front side of base plate is facing forward when installing.

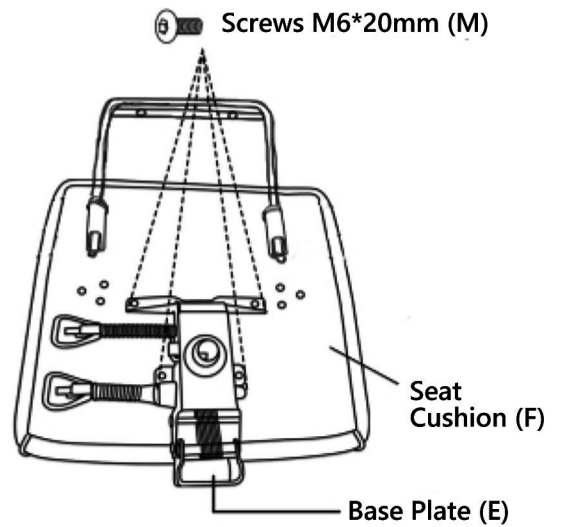

Step 5

Attach armrest frame (I) to the seat cushion (F) with 6 M6*25mm (N).

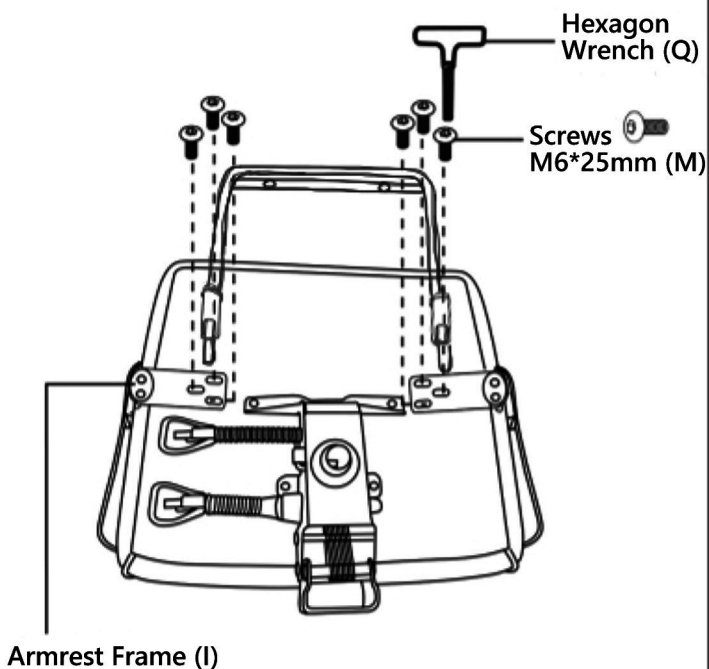

Step 6

Align the air rod (D) with the hole in the middle of the base plate (E), then place the seat cushion (F) on the air rod (D), and press the seat cushion (F) from the top down to fix on.

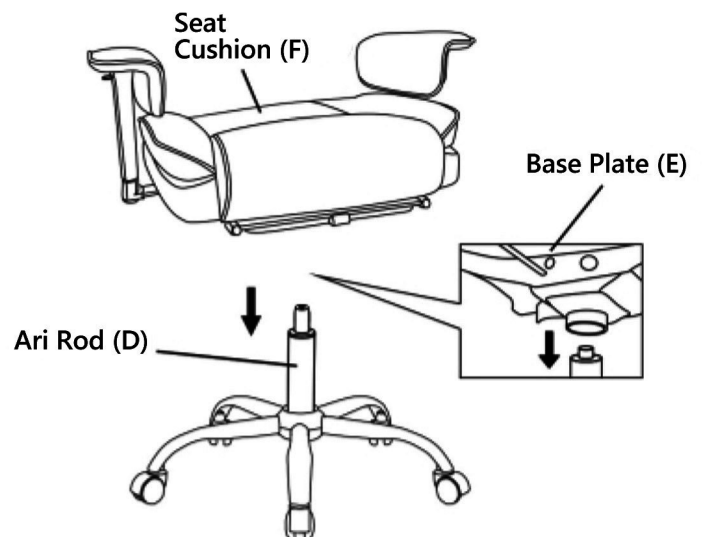

Step 7

Fix the steel plate (J) to backrest (G) with 4 M6*30 screws (O)

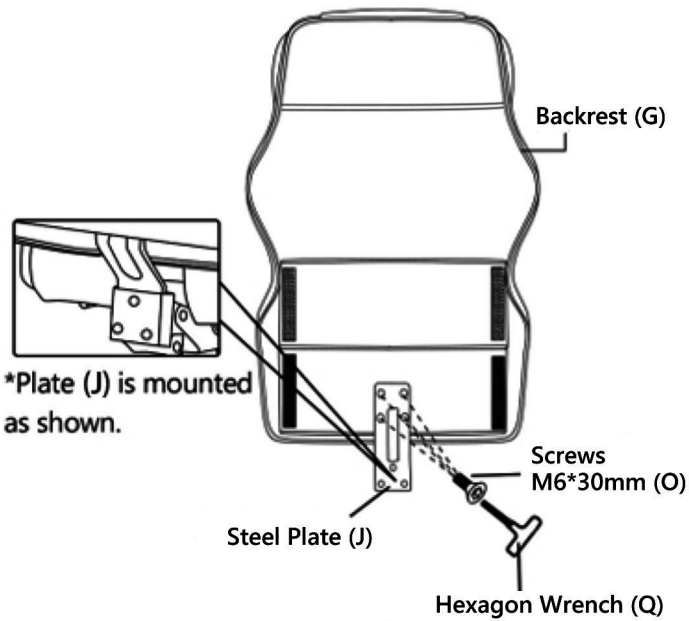

Step 8

After the steel plate (J) is connected to the backrest (Step 7), place the backrest on seat cushion and insert the steel plate (J) into the base plate (E), then tighten 3 M8*20 screws (P)

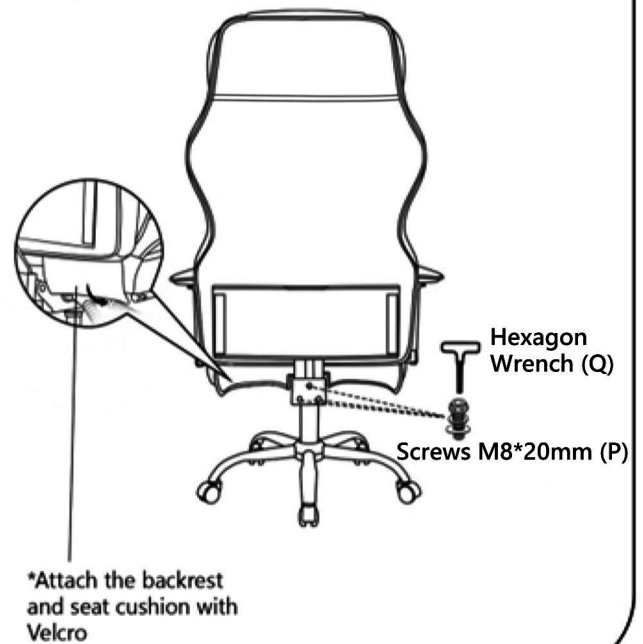

Step 9

Now pull out the Foot Bracke and fix the Footrest Cushion (L) to the Foot Bracke with 2 M6*25mm screws (N). After completing the installation, push it back.

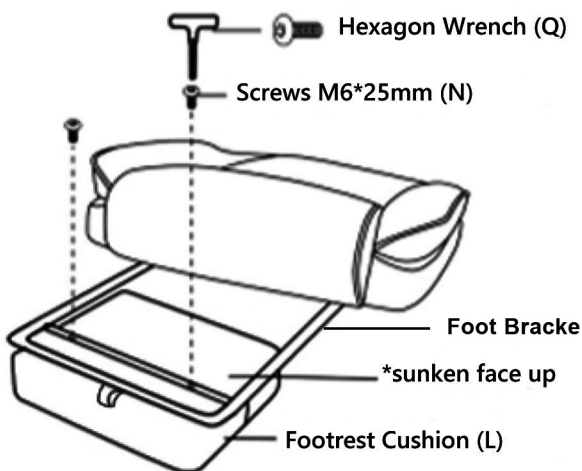

Step 10

Done!

*Please not exceed maximum load 500lbs.

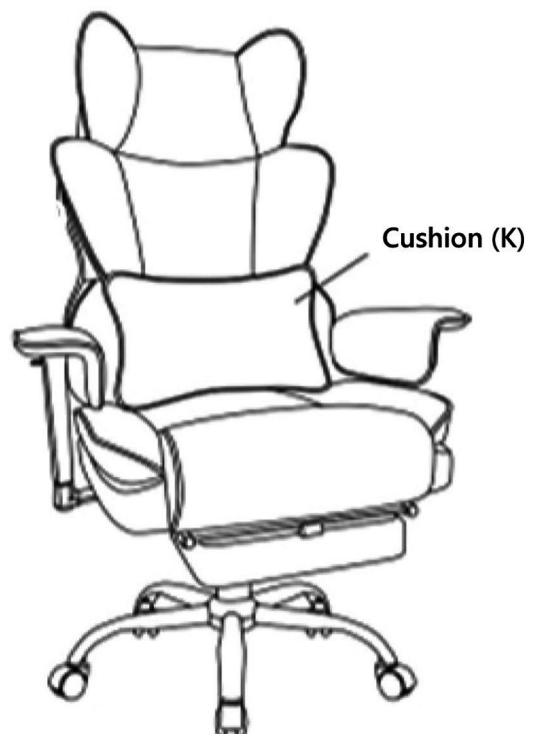

Instructions for Use

***Please stand up while raising the seat height.**

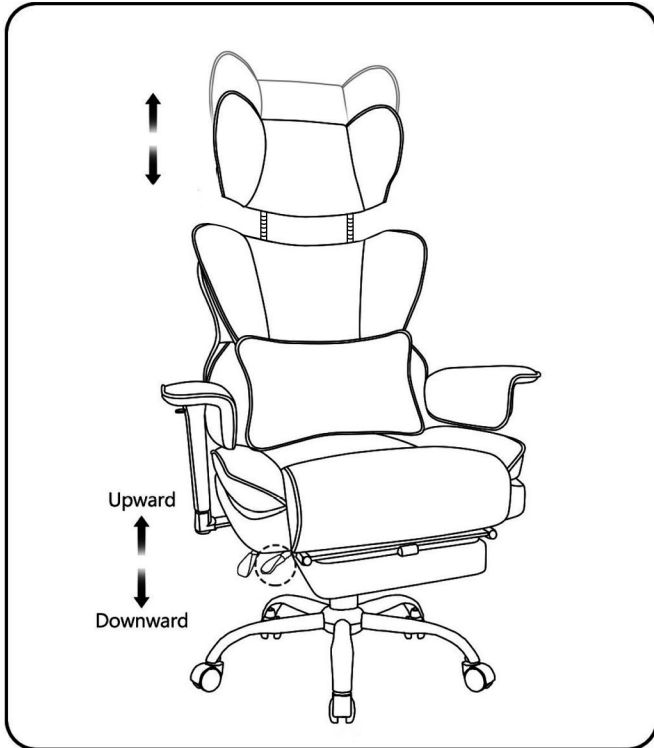

Up-down Adjustment

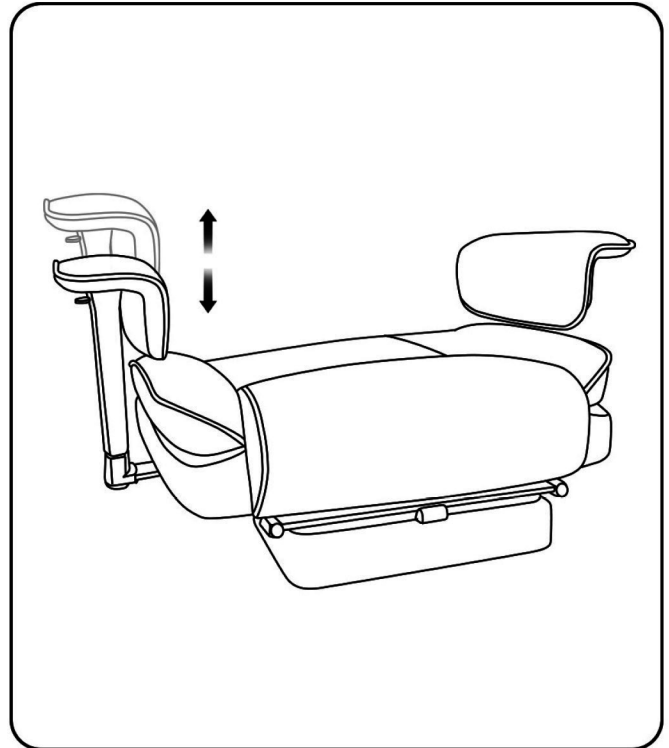

Adjustable Armrests



With Footrest

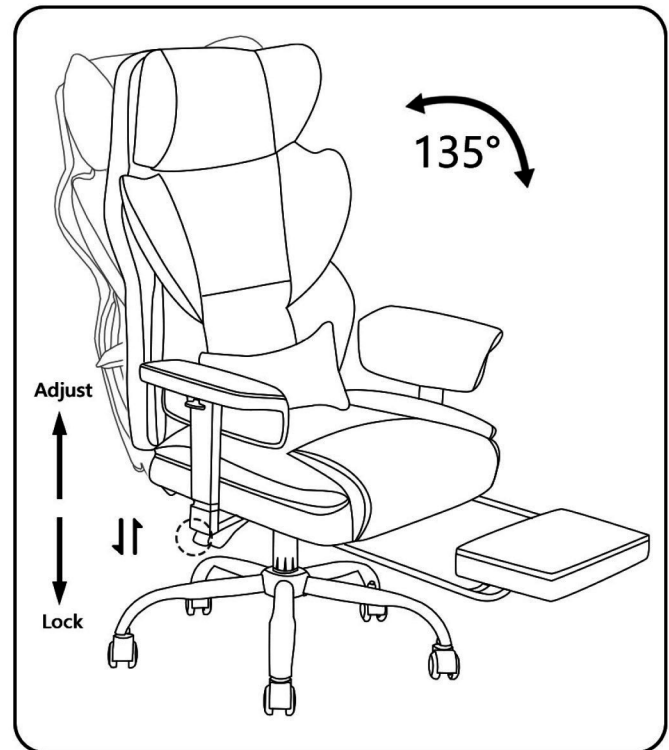

Backrest Adjustment

Thanks for purchasing our products. Please read this manual before assembly. And please assemble in order. After the assembly, keep the instruction properly. Make sure all the parts are included (21 kinds in total).