

WARNING!

Children have died from furniture tipover. Fixed wall device have been included with this product;you must install the fixed wall device according to these instructions in order to minimize the risk of furniture.If you have any questions about this product or the Fixed wall device , please contact us immediately.

Never allow children to climb or hang on furniture,including drawers or cabiner doors.

In addition to installing the restrains,to help prevent tip-over.







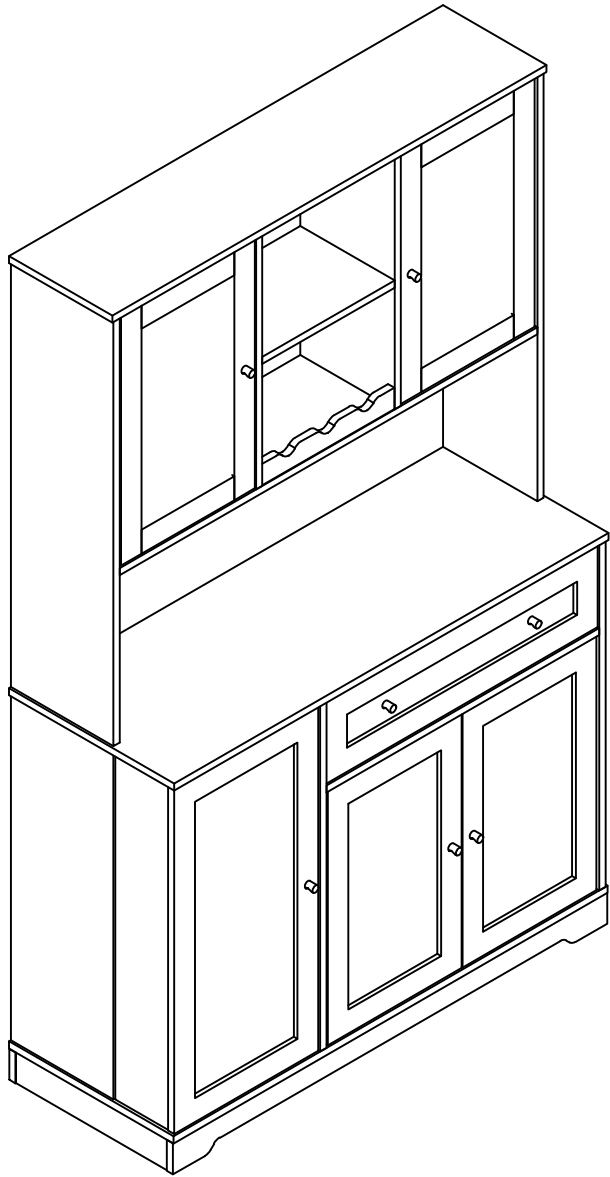

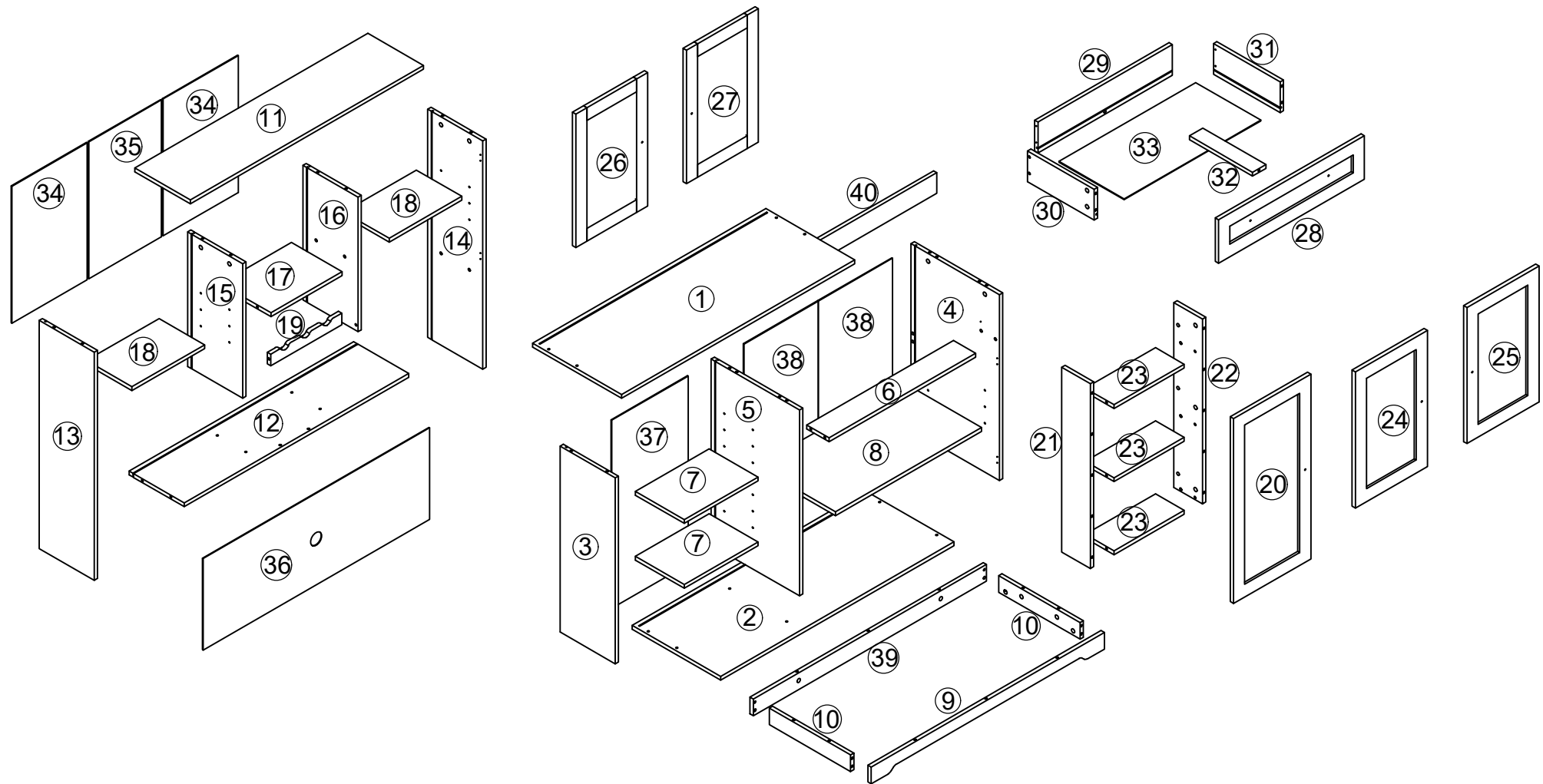



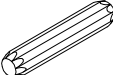

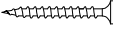
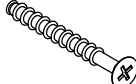
1. Never put a TV or other heavy objects on top of this product.
2. Do not stand on the product.

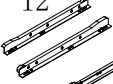
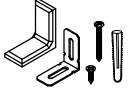
! WARNING	
	Children have died from furniture tipover. To reduce the risk of furniture tipover: <ul style="list-style-type: none">• ALWAYS install tipover restraint provided.• NEVER put a TV on this product.• NEVER allow children to stand, climb or hang on drawers, doors, or shelves.• NEVER open more than one drawer at a time.• Place heaviest items in the lowest drawers.• Do not defeat or remove the drawer interlock system. <p><i>This is a permanent label. Do not remove!</i></p>
	

DRY24009





A	B	C	D	E	F	G	H	I	J
									
60PCS	60PCS	24PCS	86PCS	4PCS	14PCS	3PCS	20PCS	1PCS	2PCS
K	L	M	N	O	P	Q	R		
									
5PCS	7PCS	2PCS	5PCS	8PCS	3PCS	26PCS	26PCS		

1

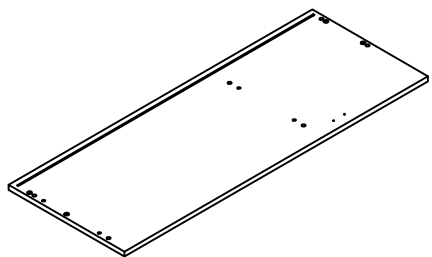

1050*400 1PS

2

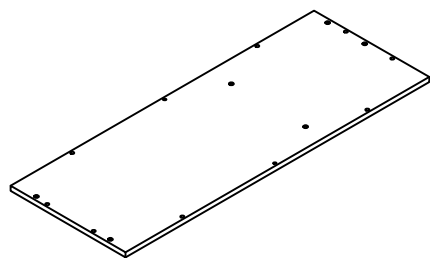

1050*398 1PS

3

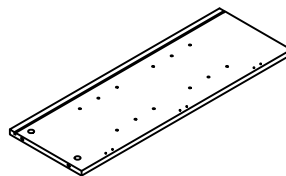

725*248 1PS

4

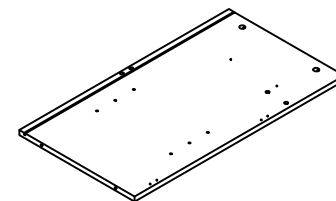

725*398 1PS

5

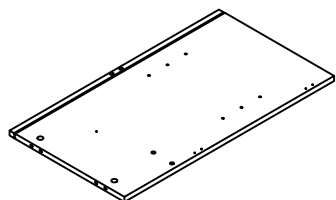

725*398 1PS

6

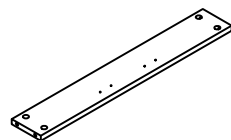

660*100 1PS

7

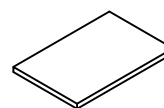

332*220 2PS

8

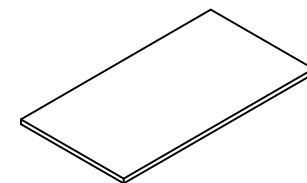

657*355 1PS

9

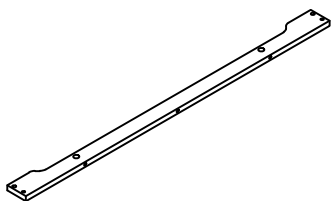

1050*65 1PS

10

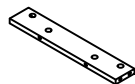

366*65 2PS

11

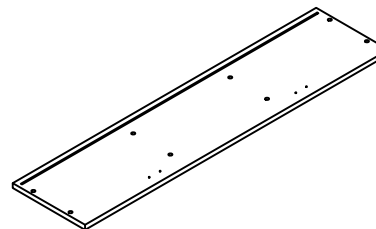

1050*250 1PS

12

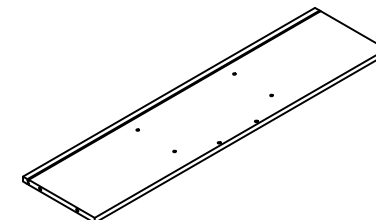

1010*248 1PS

13

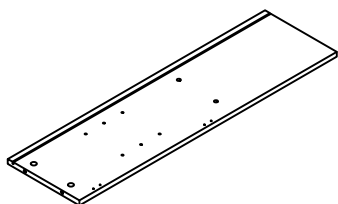

890*248 1PS

14

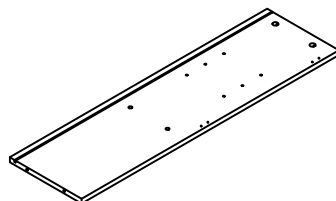

890*248 1PS

15

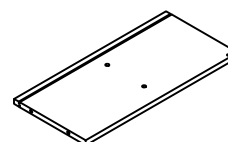

525*248 1PS

16

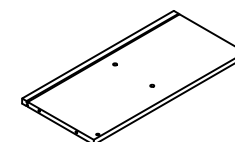

525*248 1PS

17

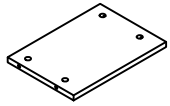

320*228 1PS

18

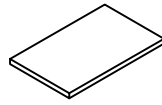

327*205 2PS

19



320*45 1PS

20

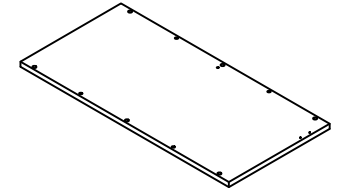

721*348 1PS

21

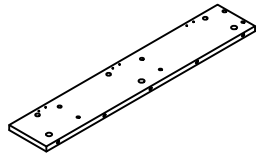

721*129 1PS

22

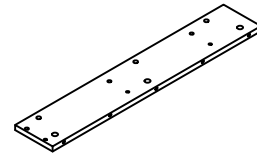

721*129 1PS

23

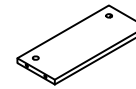

316*129 3PS

24

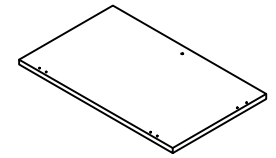

531*324 1PS

25

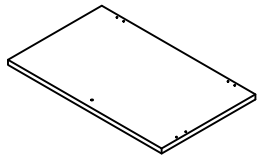

531*324 1PS

26

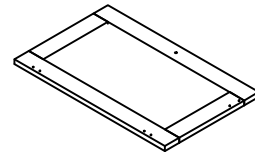

521*324 1PS

27

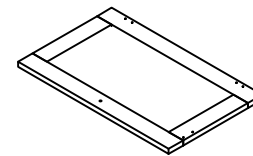

521*324 1PS

28

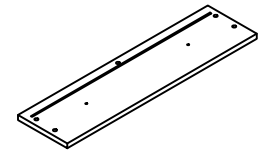

656*170 1PS

29

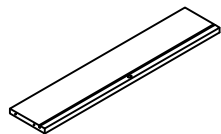

605*120 1PS

30

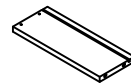

300*120 1PS

31

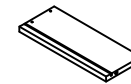

300*120 1PS

32

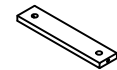

284*60 1PS

33

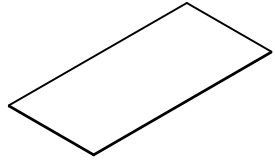

615*293 1PS

34

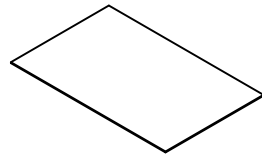

534*339 2PS

35

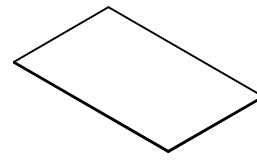

534*327 1PS

36

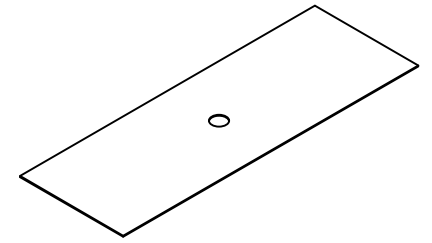

357*1020 1PS

37

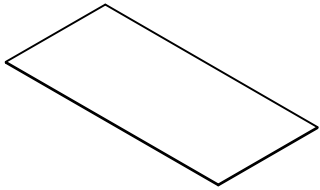

734*344 1PS

38

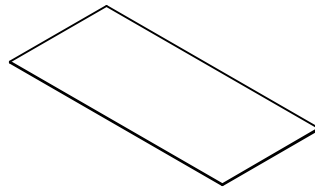

734*334.5 2PS

39

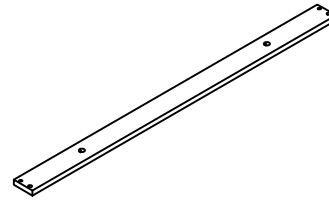

1050*65 1PS

40

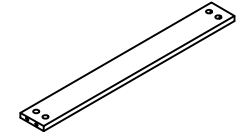

660*80 1PS



Hardware installation demonstration

NOTE: Please make sure "A" hardware tightened and can't be pulled out!

I

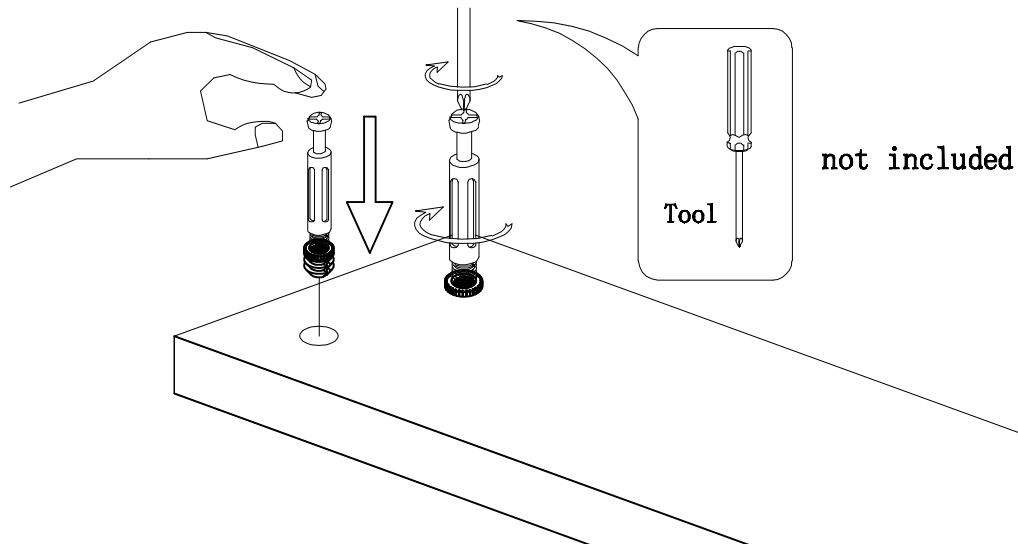

II

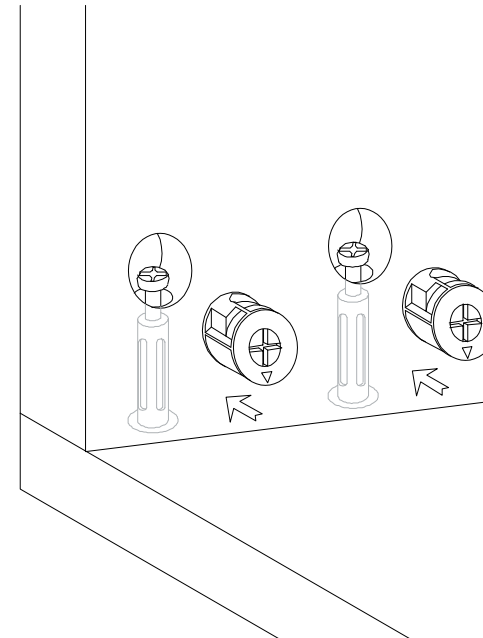

III

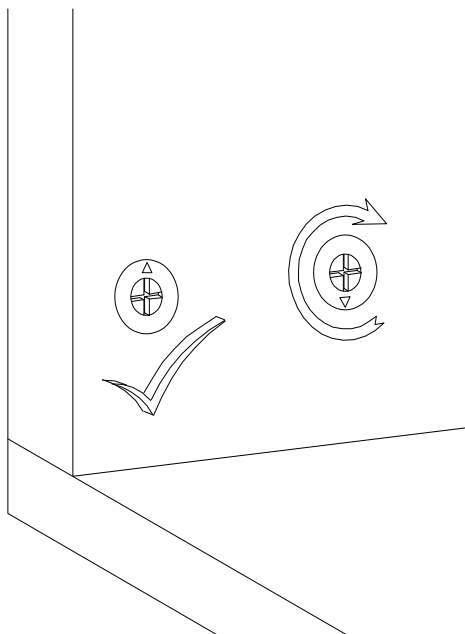





IV

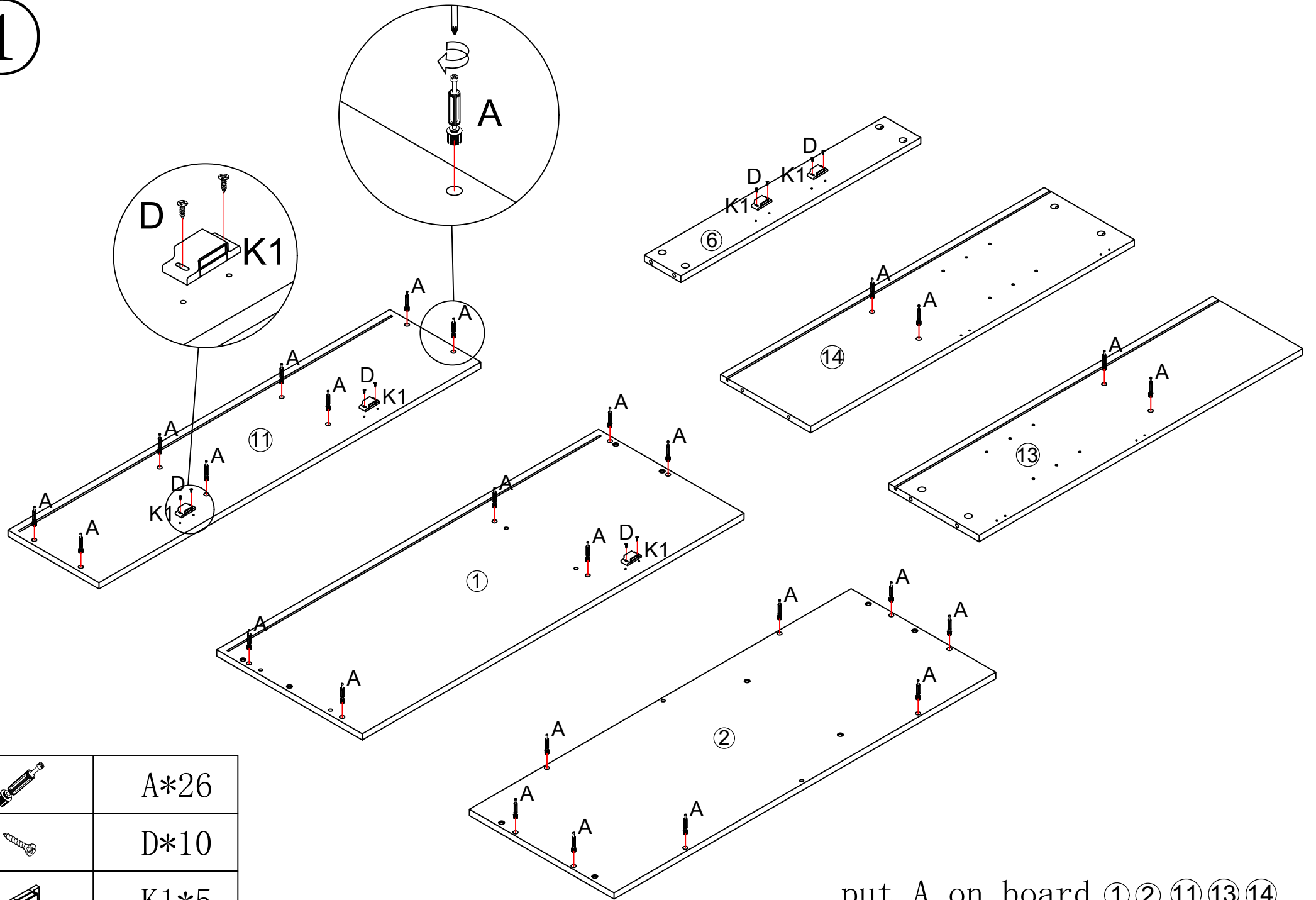

Scan QR code for assembly video

1





	A*26
	D*10
	K1*5

put A on board ① ② ⑪ ⑬ ⑭

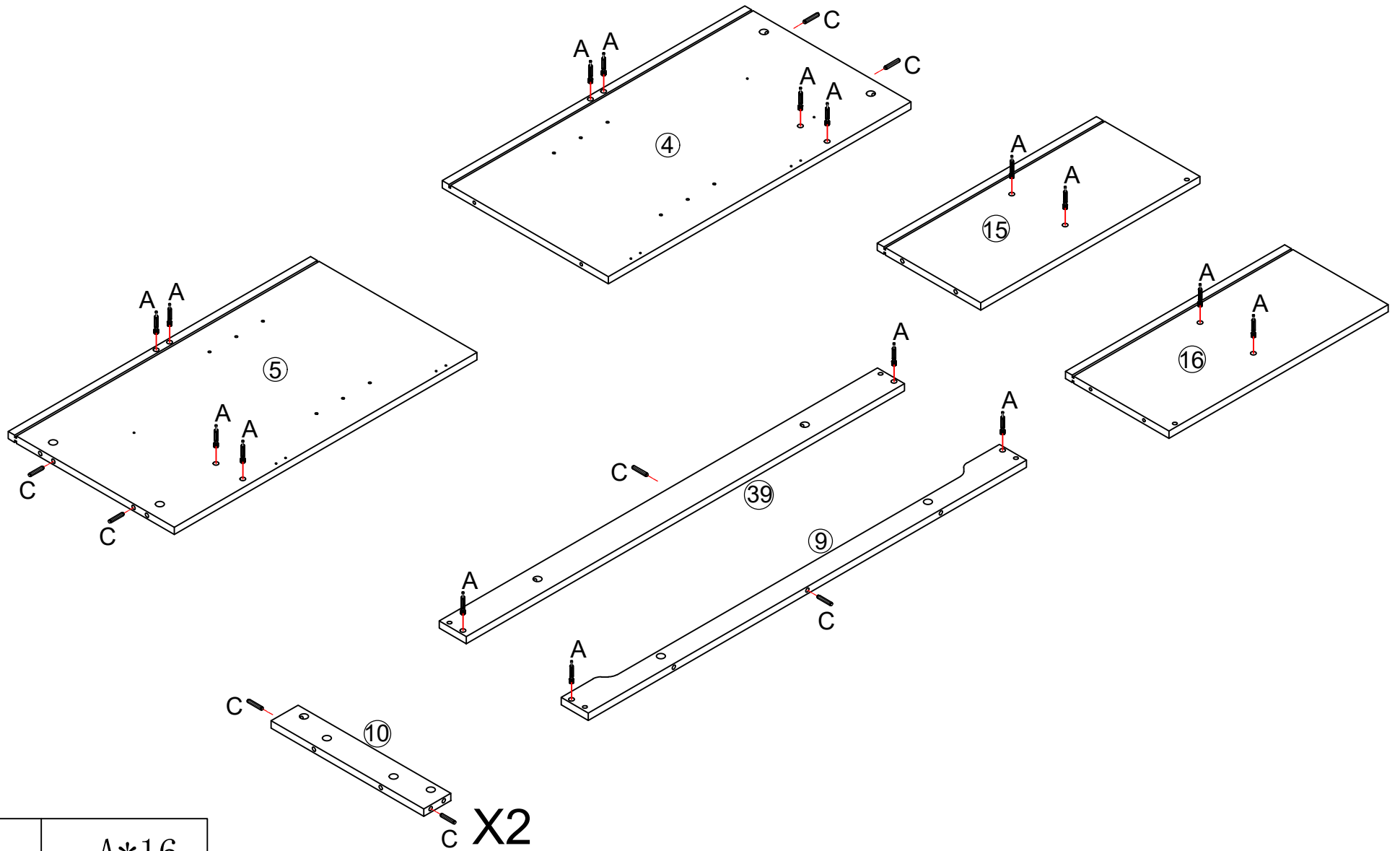
2





	A*16
	C*10

put A on board ④ ⑤ ⑨ ⑮ ⑯ ⑳
put C on board ④ ⑤ ⑨ ⑩ ㉑

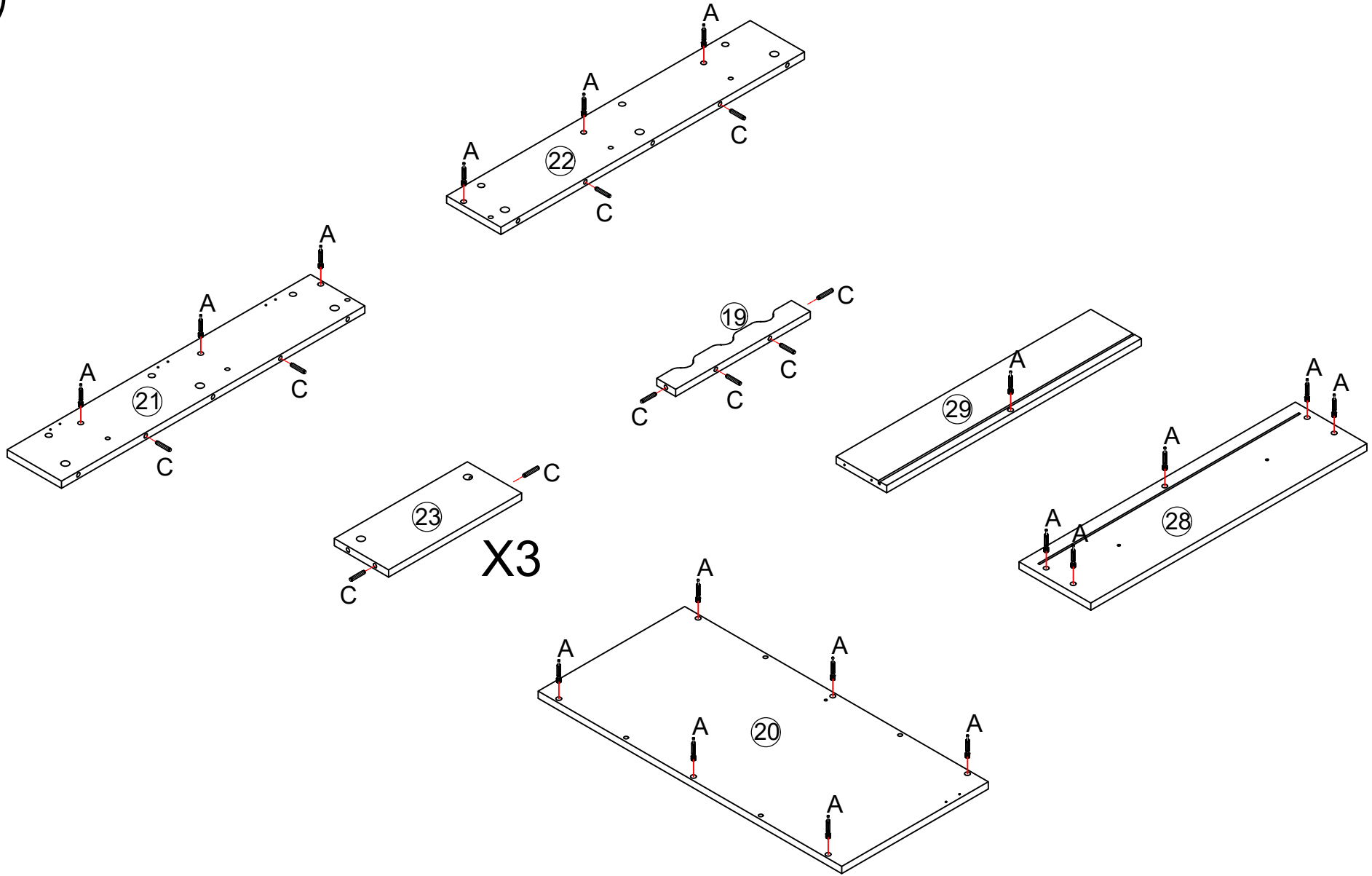
3



	A*18
	C*14

put A on board 20 21 22 28 29
put C on board 19 21 22 23

4

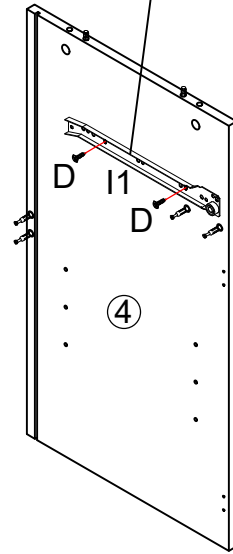
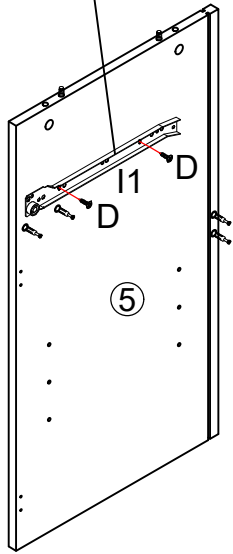
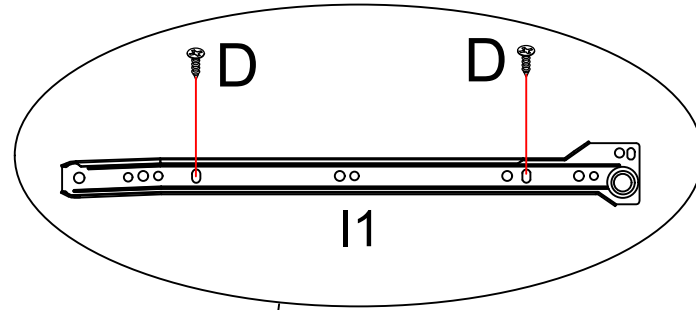
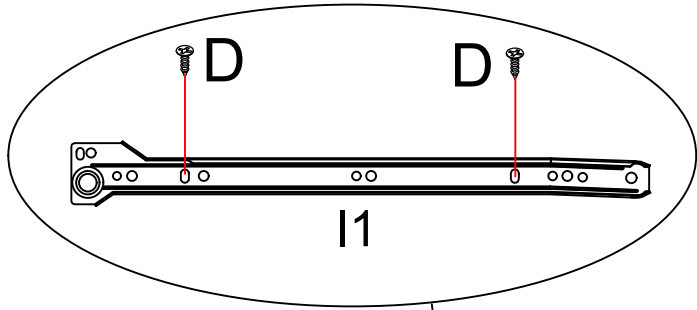

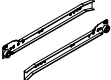
	D*4
	I1*1

5

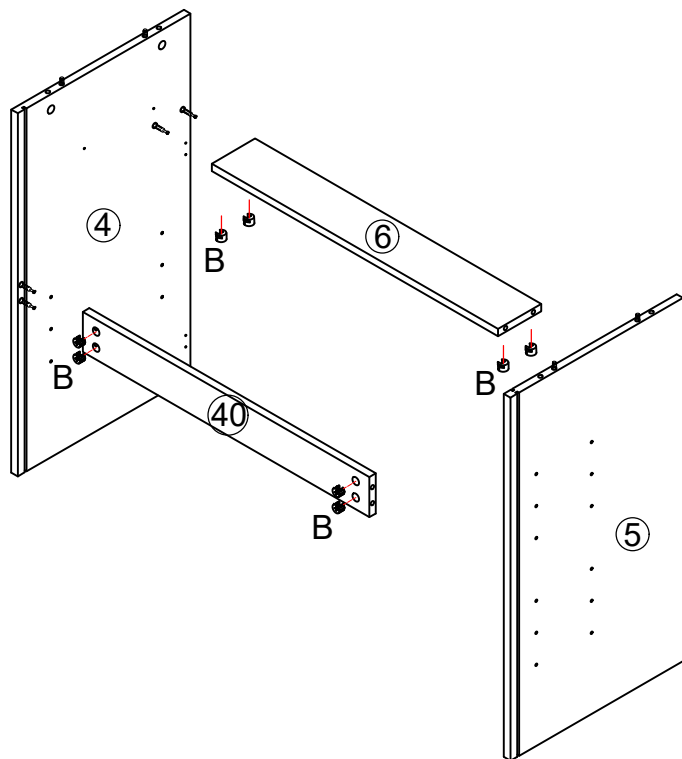

Make sure the arrow on the screw align to the hole on the side.

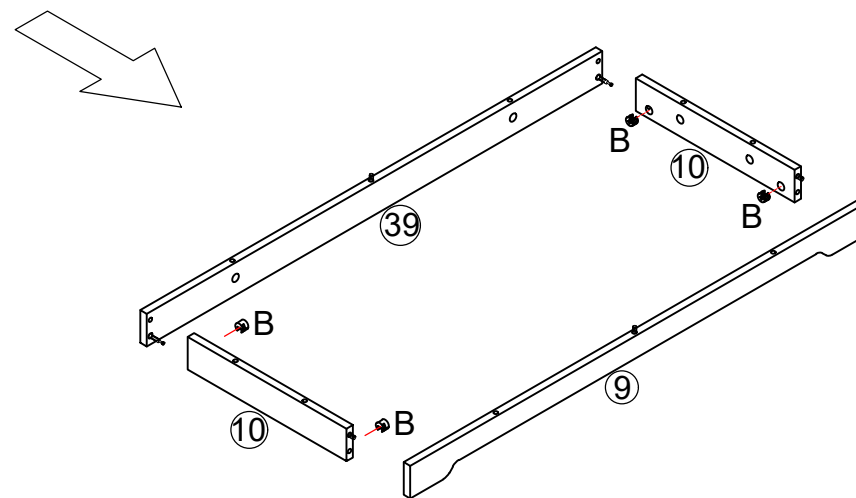
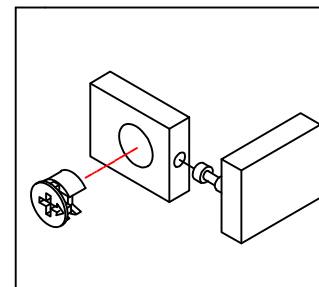

B*12

6

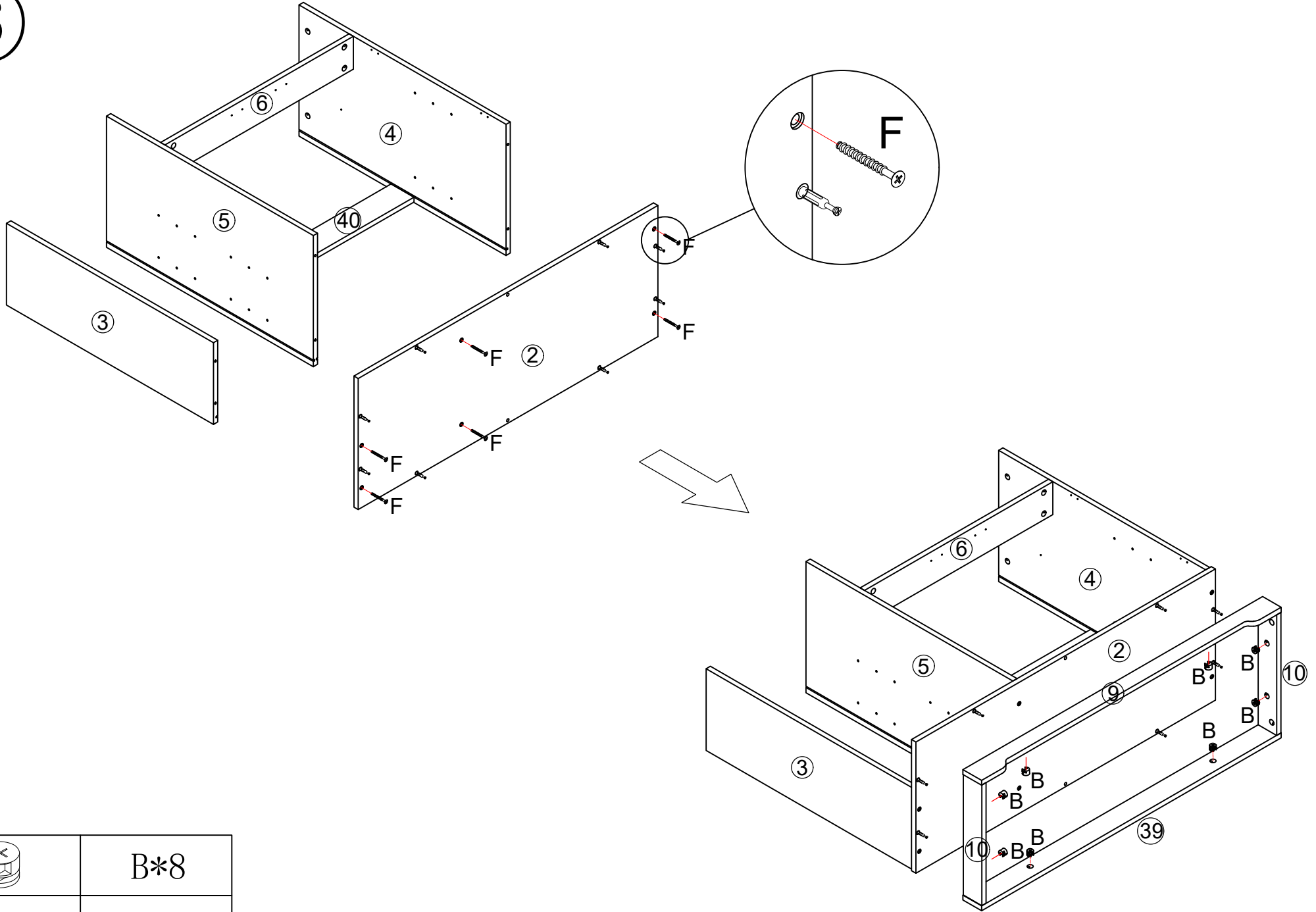

B*8

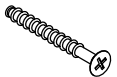

F*6

7

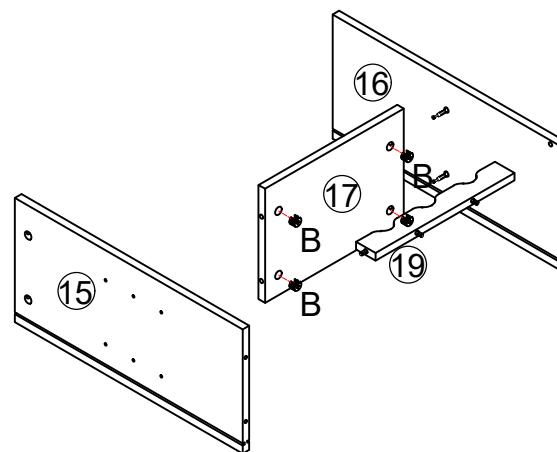
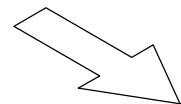
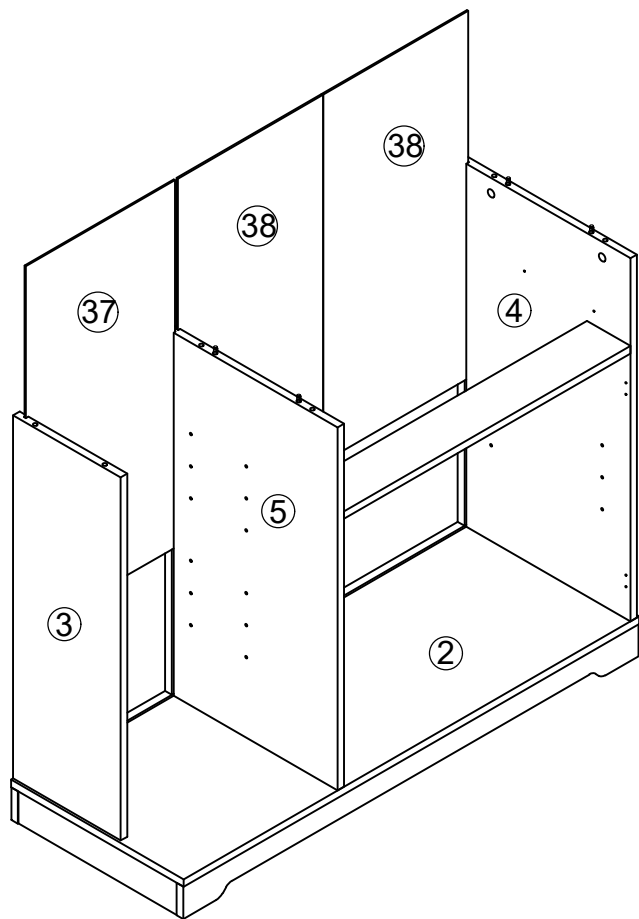

B*4

8

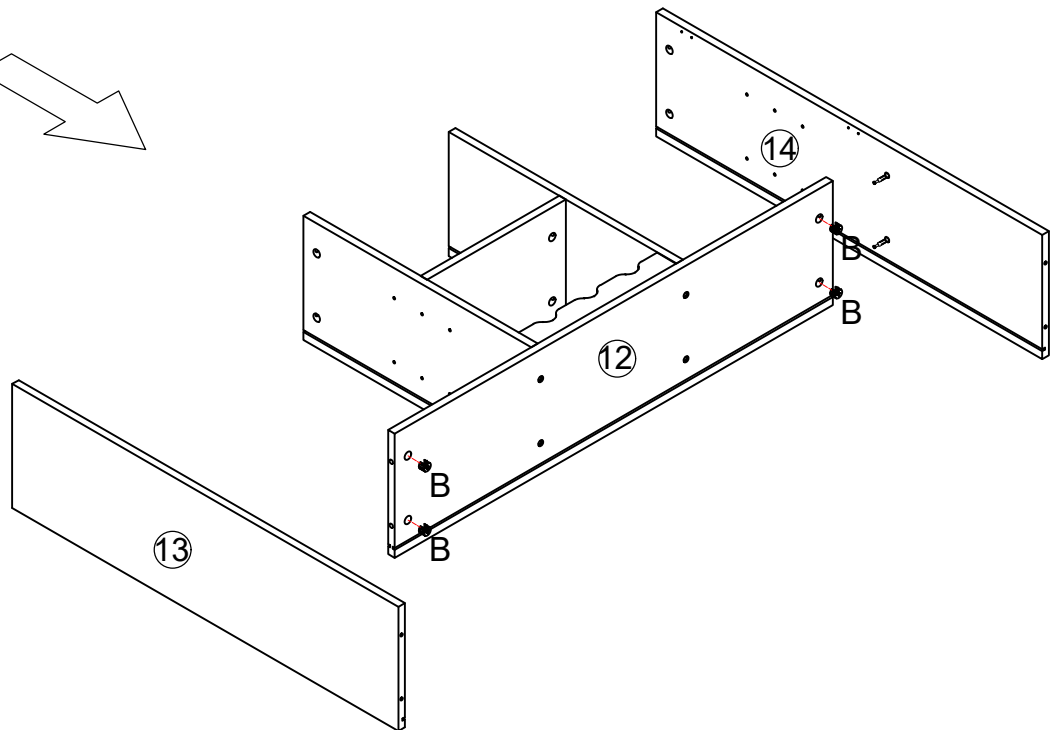
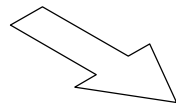
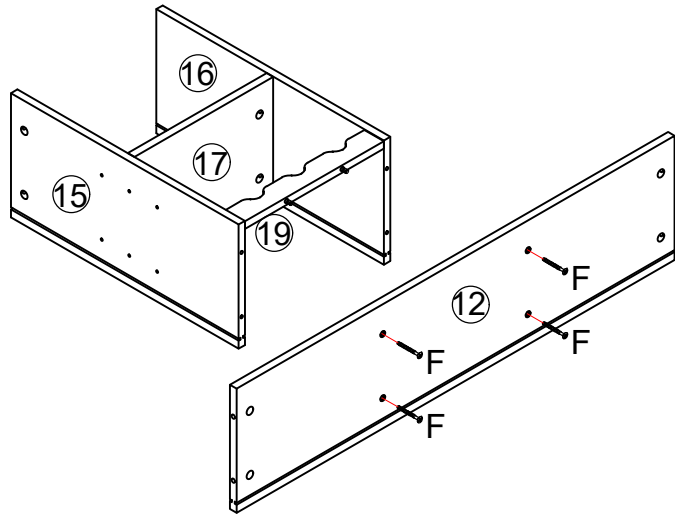

B*4



F*4

9

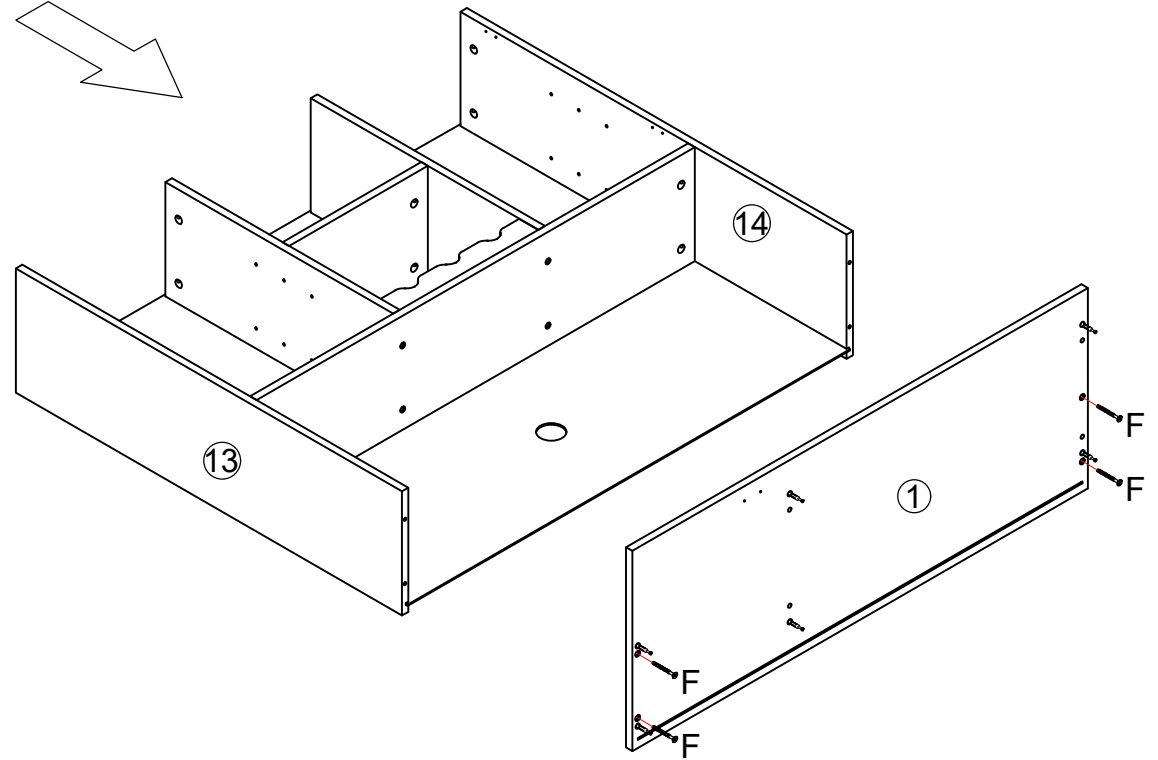
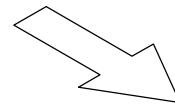
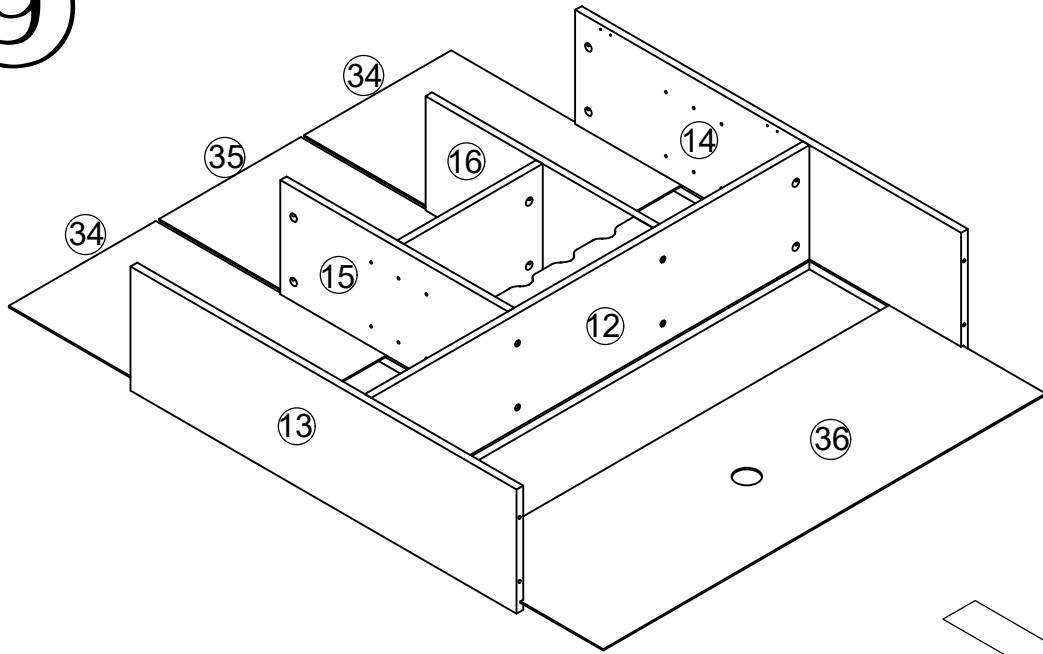

F*4

10

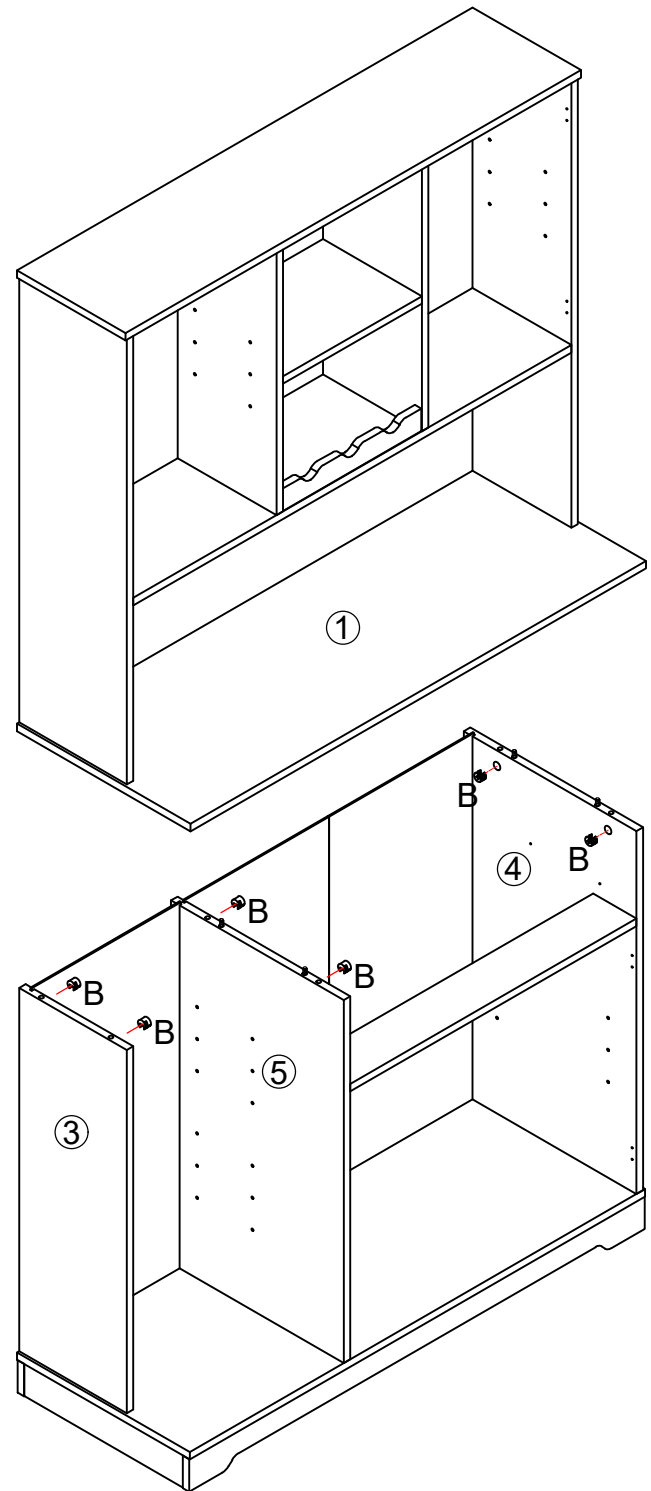
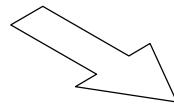
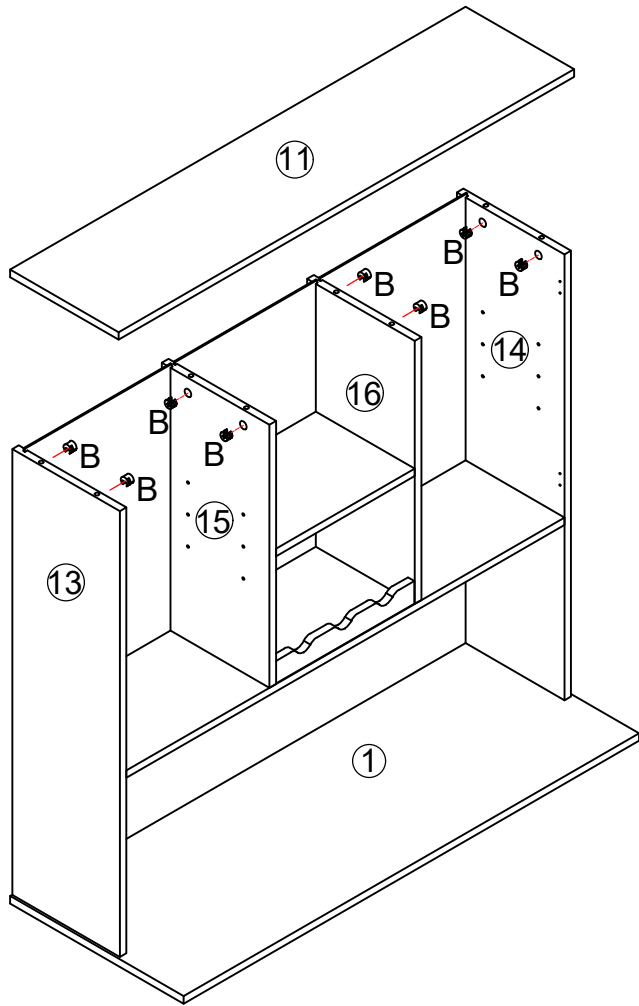

B*14

11

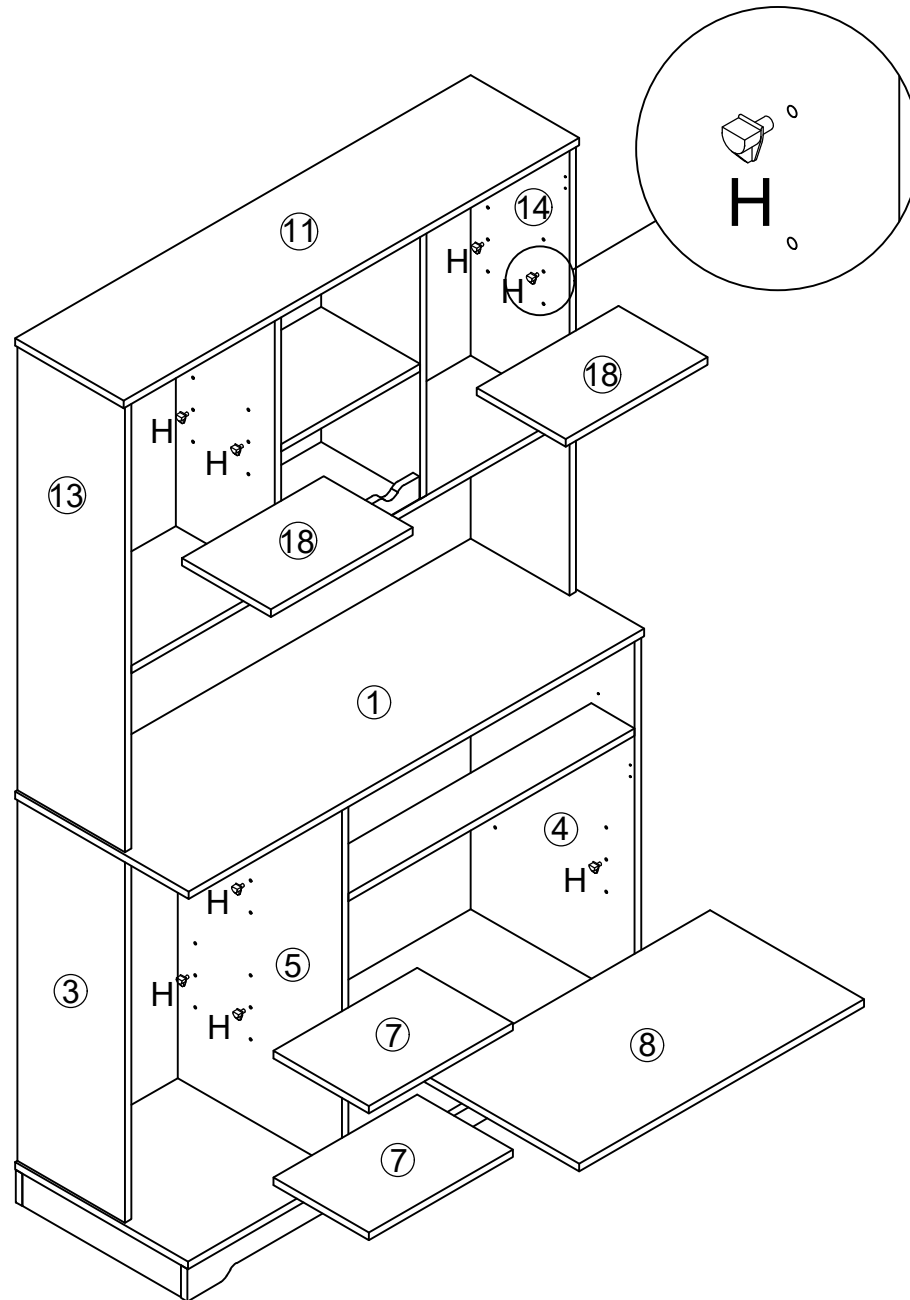

H*20

12

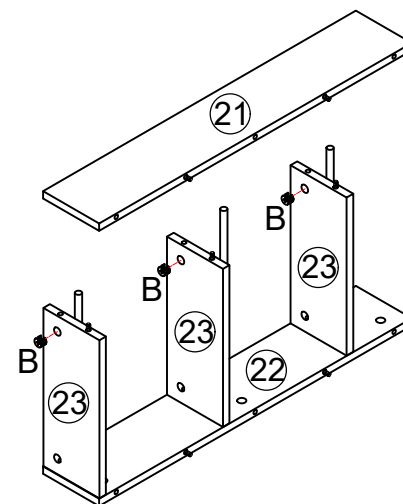
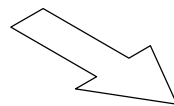
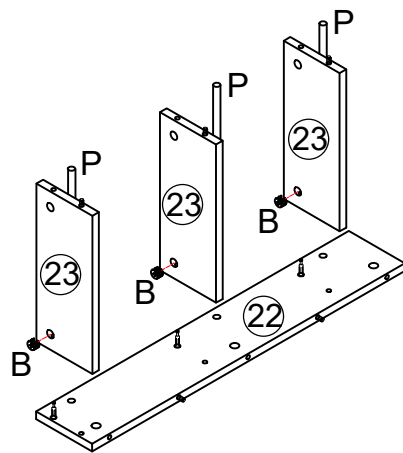

B*6



P*3

13

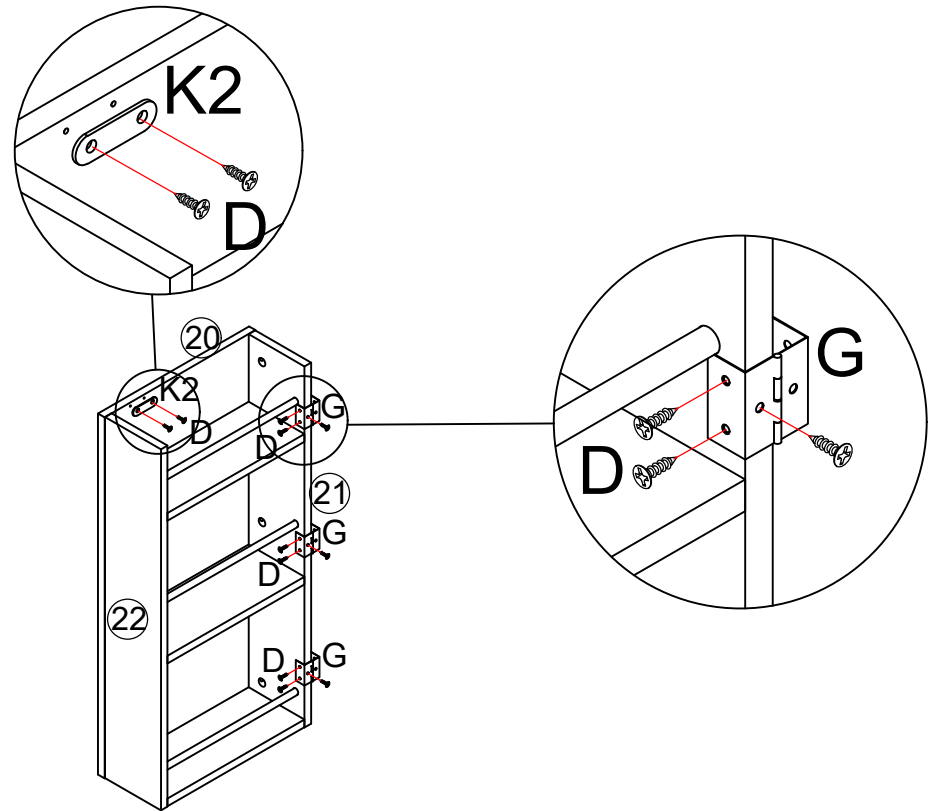
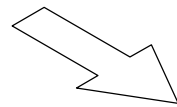
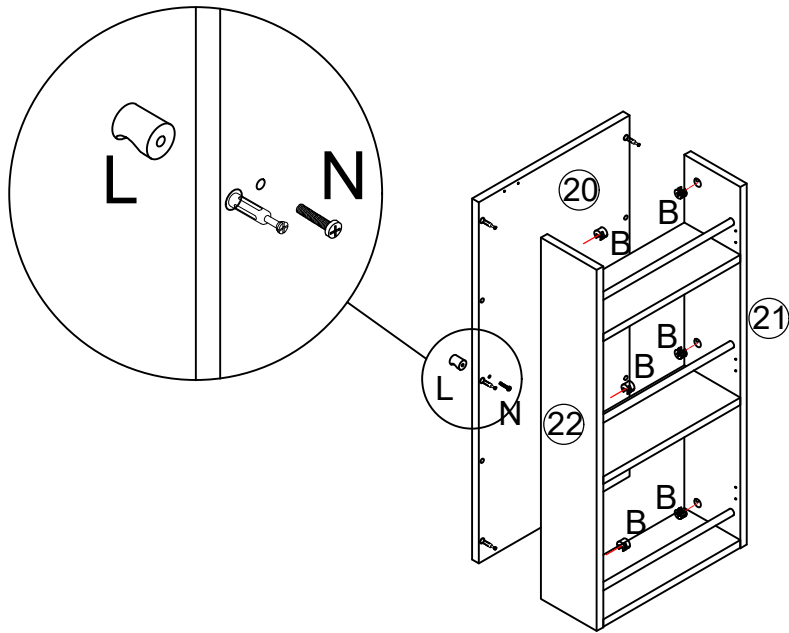

B*6



D*11



K2*1



G*3



L*1



N*1

14

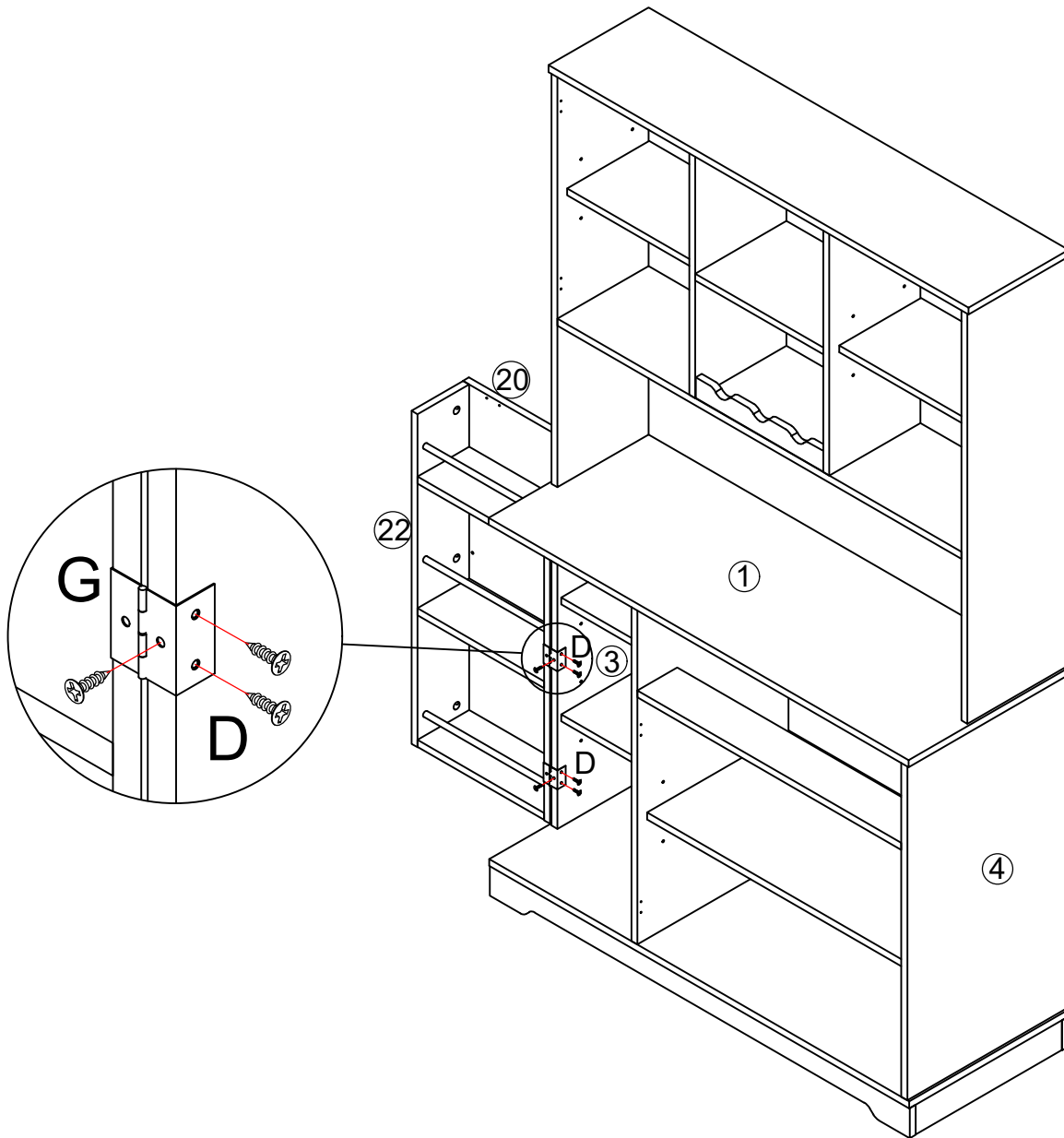

D*9

15

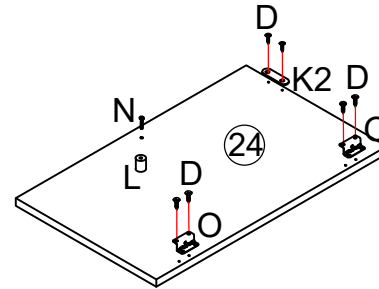
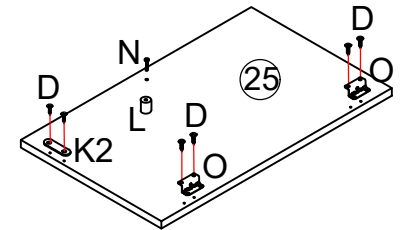
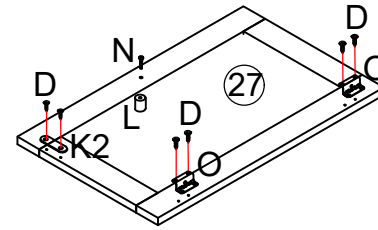
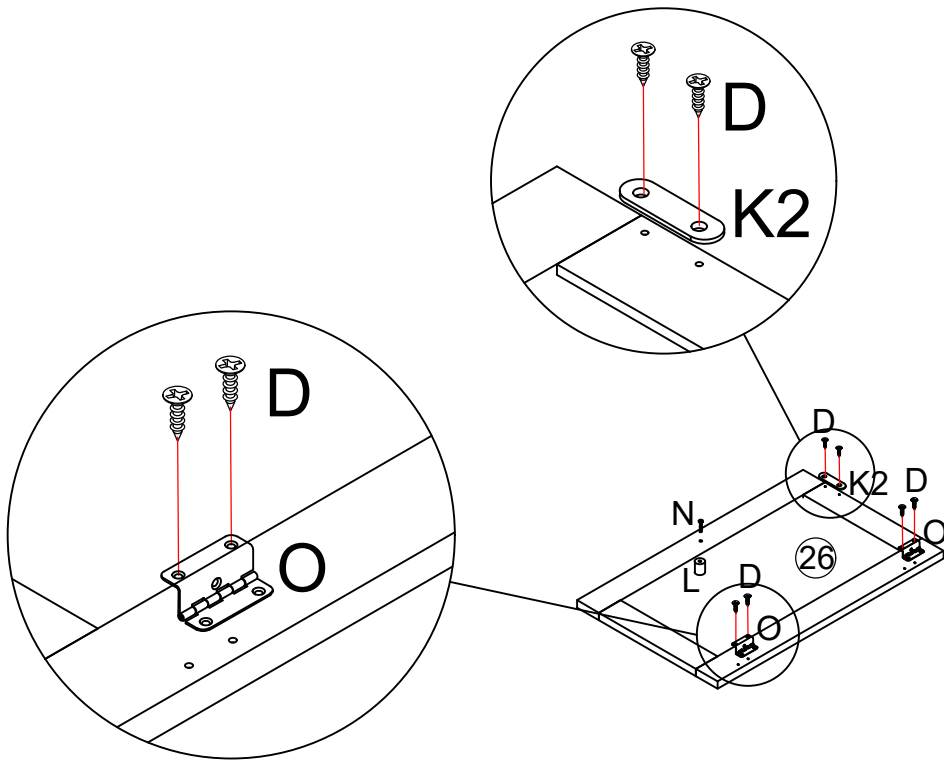

D*24



K2*4



L*4



N*4



O*8

16

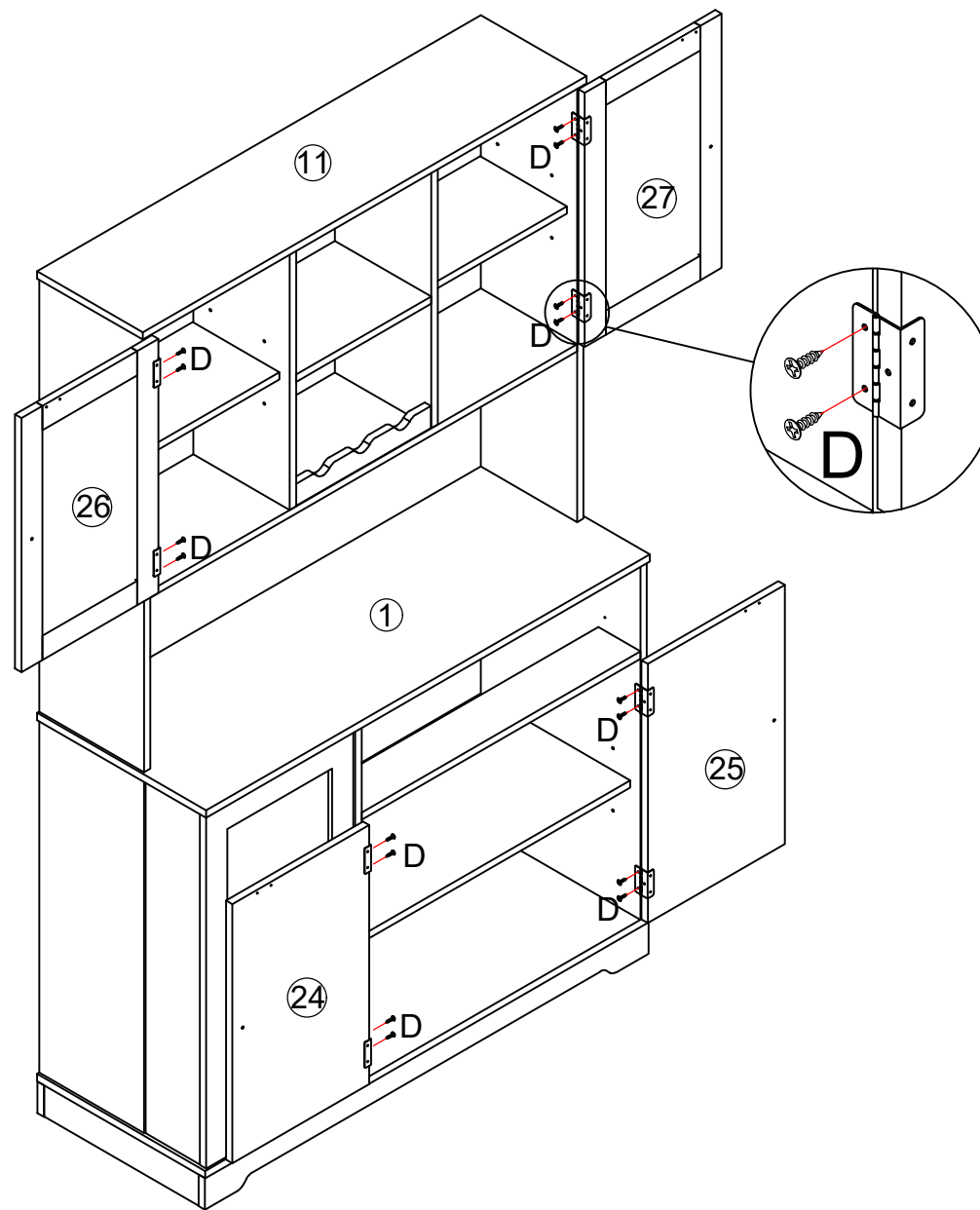

D*24

17

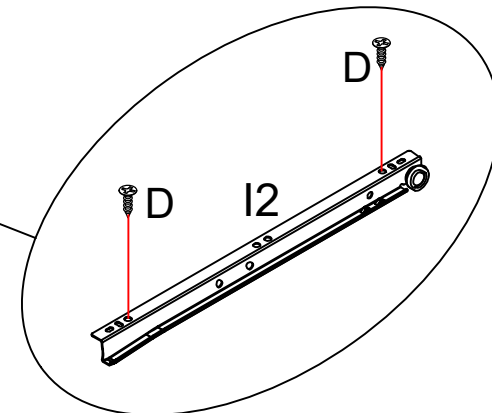
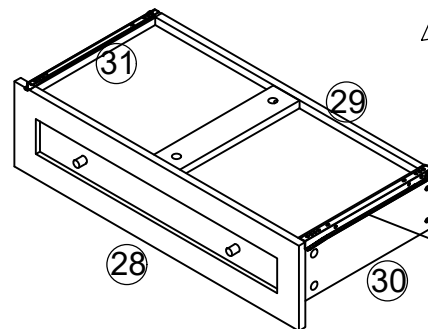
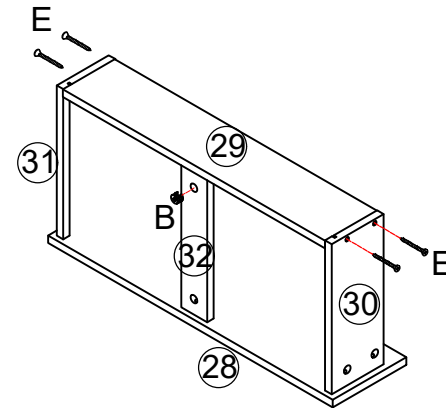
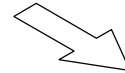
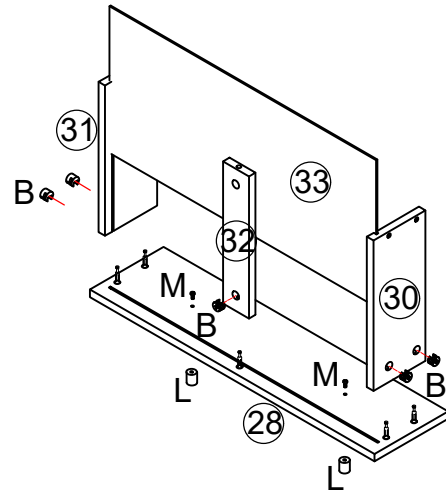

B*6



D*4



E*4

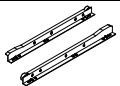

I2*1



L*2



M*2

18

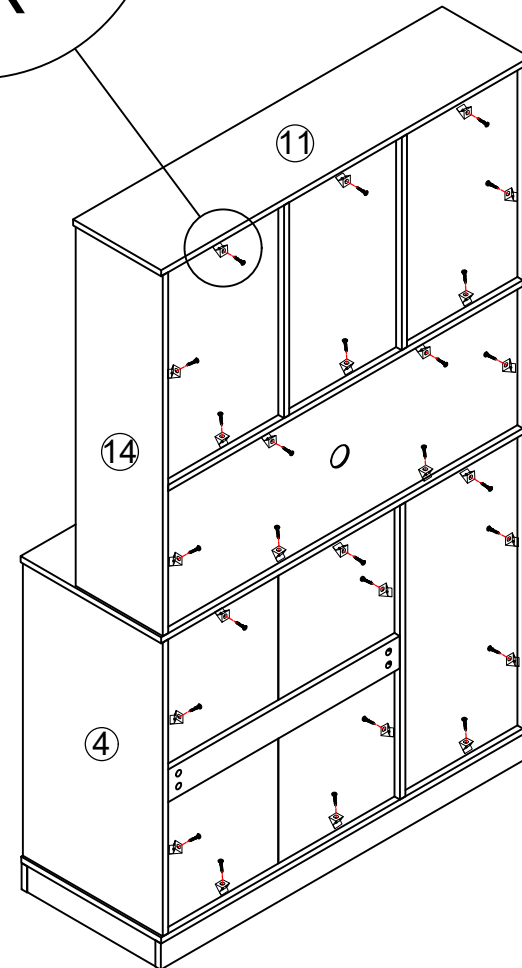
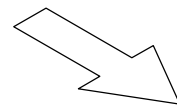
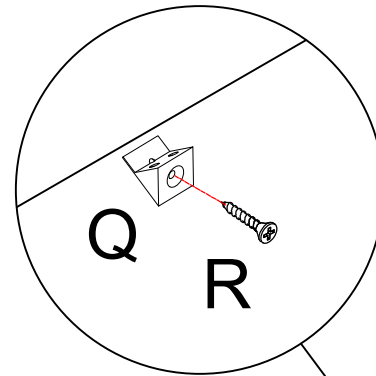
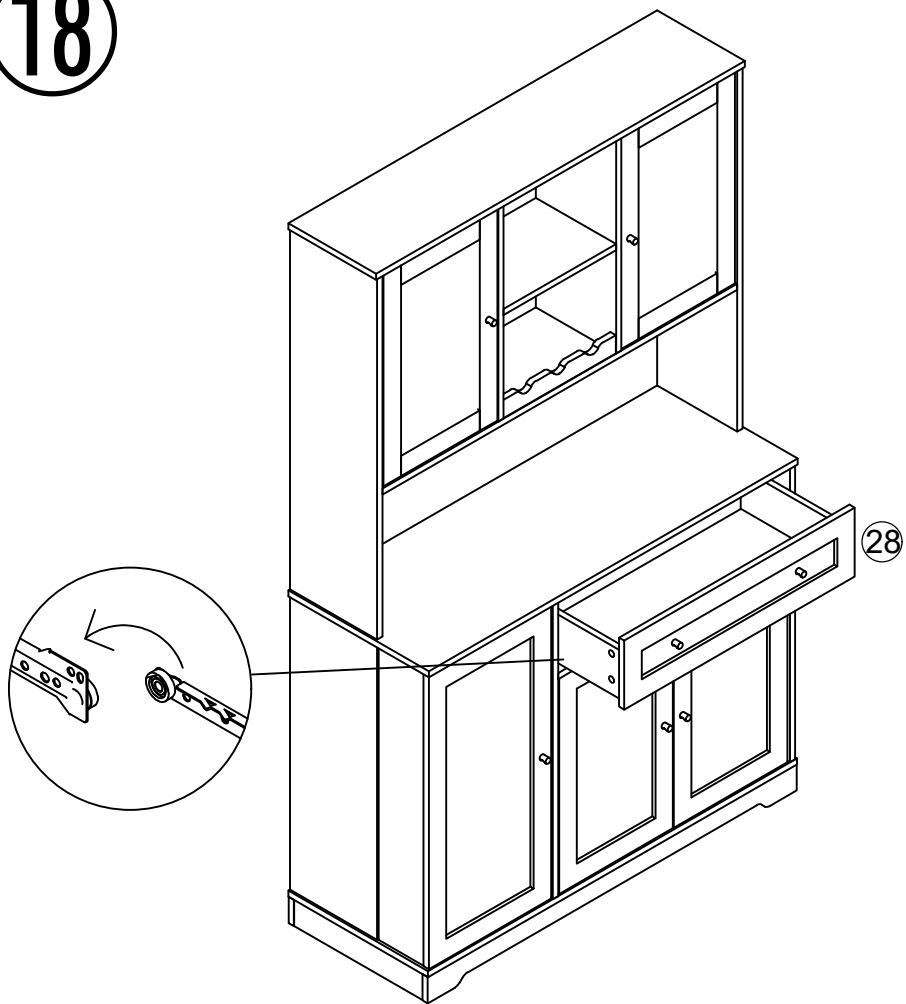

Q*26



R*26

19

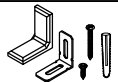
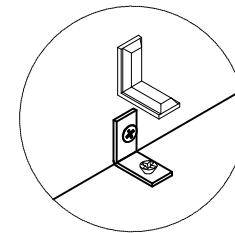
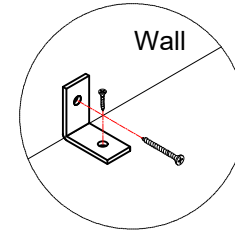
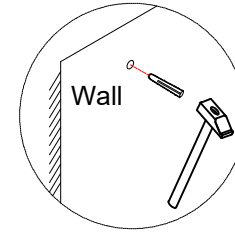
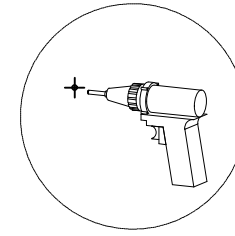
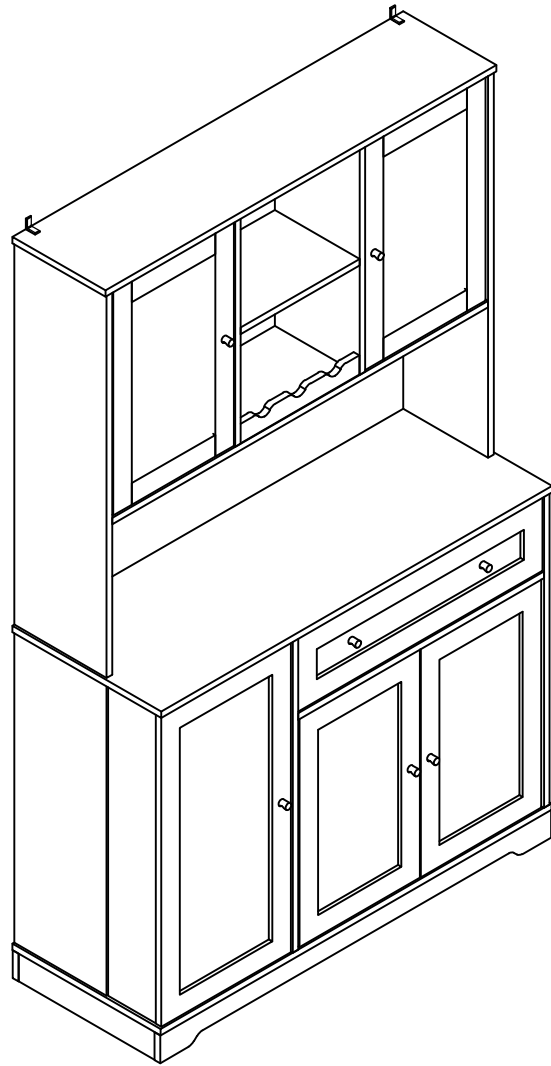

J*2

Please install tip-proof fitting.