



- Ⓛ Deur volgen Sie stets die Anleitung des Herstellers!
- Ⓛ Please generally follow the manufacturer's instructions!
- Ⓛ Suivez toujours les instructions du fabricant!
- Ⓛ Volg steeds de handleiding van de producent!
- Ⓛ Siga siempre las instrucciones del fabricante!
- Ⓛ Stale przestrzegaj instrukcji producenta!

- Ⓛ Всегда следуйте инструкции производителя!
- Ⓛ Seguire sempre le istruzioni del produttore!
- Ⓛ Mindig tartsa be a gyártó utasításait!
- Ⓛ Siga sempre as instruções do fabricante!
- Ⓛ Vždy dodržujte pokyny výrobce!
- Ⓛ Vždy dodržujte pokyny výrobu!



- Ⓛ Verwenden Sie zur Reinigung nur ein feuchtes Tuch!
- Ⓛ Please only clean with a damp cloth!
- Ⓛ N'utilisez qu'un chiffon humide pour le nettoyage!
- Ⓛ Gebruik voor de reiniging enkel een vochtige doek!
- Ⓛ Para limpiar utilice sólo un paño húmedo!
- Ⓛ Do czyszczenia używaj wilgotnej szmatki!

- Ⓛ Для очистки используйте только влажную ткань!
- Ⓛ Per la pulizia, utilizzare solo un panno umido!
- Ⓛ A tisztításához elegendő egy nedves kendő használatát!
- Ⓛ Para a limpeza use apenas um pano húmido!
- Ⓛ Pro čištění používejte pouze vlhký hadřík!
- Ⓛ Na čistenie používajte iba vlhkú handričku!

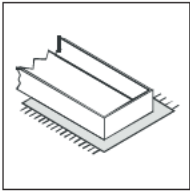

- Ⓛ Bauen Sie das Produkt auf einer Unterlage auf!
- Ⓛ Please mount the product on a bottom support!
- Ⓛ Montez le produit sur une base!
- Ⓛ Monteer het product op een basis!
- Ⓛ Monte el producto sobre una base!
- Ⓛ Rozkładaj produkt na podkładzie!

- Ⓛ Собирайте изделие на подстилке!
- Ⓛ Montare il prodotto su un supporto!
- Ⓛ Az összeszereléskor helyezzen a termék alá megfelelő alátétet!
- Ⓛ Monte o produto numa superfície plana!
- Ⓛ Výrobek smontujte na pevném podkladu!
- Ⓛ Výrobok zmontujte na pevnom podklade!



- Ⓛ Verwenden Sie das Produkt nur in Innenräumen!
- Ⓛ Please exclusively use the product indoors!
- Ⓛ N'utilisez le produit qu'à l'intérieur!
- Ⓛ Gebruik het product enkel binnenshuis!
- Ⓛ Utilice el producto sólo en interiores!
- Ⓛ Używaj produkt tylko w pomieszczeniach wewnętrznych!

- Ⓛ Используйте изделие только во внутренних помещениях!
- Ⓛ Utilizzare il prodotto solo in ambienti interni!
- Ⓛ A termék csak bel terekben használható!
- Ⓛ Use o produto apenas no interior!
- Ⓛ Používejte výrobek pouze uvnitř!
- Ⓛ Výrobok používajte len vo vnútri!



- Ⓛ Legen Sie die Beschläge zusammen und prüfen Sie die Vollständigkeit!
- Ⓛ Please join the fittings and verify their completeness!
- Ⓛ Pliez les raccords ensemble et vérifiez qu'ils sont complets!
- Ⓛ Leg de onderdelen samen en controleer de volledigheid!
- Ⓛ Junte los accesorios y compruebe que están todos!
- Ⓛ Rozłóż poszczególne części i sprawdź kompletność!

- Ⓛ Положите фурнитуру в одно место и проверьте комплектность!
- Ⓛ Mettere insieme le guarnizioni e verificarne la completezza!
- Ⓛ Állítsa össze a sarokvasakat, és ellenőrizze, hogy épek-e!
- Ⓛ Coloque os encaixes juntos e verifique se estão completos!
- Ⓛ Složte armatury a zkontrolujte úplnost!
- Ⓛ Zložte armatúry a skontrolujte úplnosť!



- Ⓛ Bei fehlenden Teilen kontaktieren Sie den Hersteller!
- Ⓛ If parts are missing, please turn to the manufacturer!
- Ⓛ En cas de pièces manquantes, veuillez contacter le fabricant!
- Ⓛ Contacteer de fabrikant als er onderdelen ontbreken!
- Ⓛ En el caso de que falten piezas, póngase en contacto con el fabricante!
- Ⓛ W razie braku części skontaktuj się z producentem!

- Ⓛ При отсутствии каких-либо частей обратитесь к производителю!
- Ⓛ In caso di pezzi mancanti, contattare il produttore!
- Ⓛ Ha hiányozna valamelyik elem, lépjen kapcsolatba a gyártóval!
- Ⓛ Em caso de peças em falta, entre em contato com o fabricante!
- Ⓛ Pro chybějící díly kontaktujte výrobce!
- Ⓛ Ak vám chýbajú diely kontaktujte výrobu!

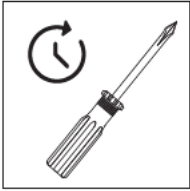

- Ⓛ Ziehen Sie die Schrauben nach einiger Zeit des Gebrauchs erneut fest!
- Ⓛ Please re-tighten the screws after having used the product for a while!
- Ⓛ Resserrer les vis après un certain temps d'utilisation!
- Ⓛ Draai de schroeven na een zekere gebruikstijd opnieuw vast!
- Ⓛ Asegure de nuevo los tornillos tras usarlo durante un tiempo!
- Ⓛ Po pewnym czasie użytkowania ponownie dokręć śruby!

- Ⓛ Спустя некоторое время использования подкрутите гайки!
- Ⓛ Stringere nuovamente le viti dopo un certo periodo di utilizzo!
- Ⓛ A használat során némi idő elteltével húzza meg újra a csavarokat!
- Ⓛ Reaperte os parafusos após algum tempo de uso!
- Ⓛ Po určité době používání šrouby znovu utáhněte!
- Ⓛ Po určitéj dobe používania skrutky znovu utiahnite!



f3 x 7



b2 x 28



c2 x 7

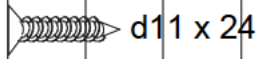

d11 x 24



d6 x 36



a1 x 7



o1 x 7

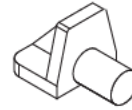

r4 x 1



o19 x 34

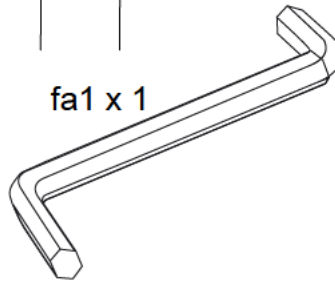

fa1 x 1

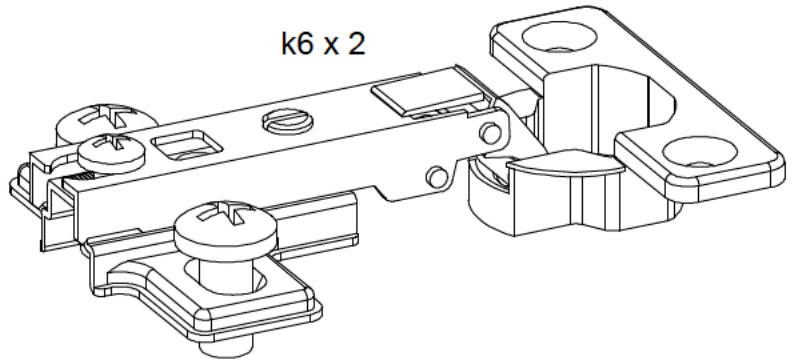

k6 x 2

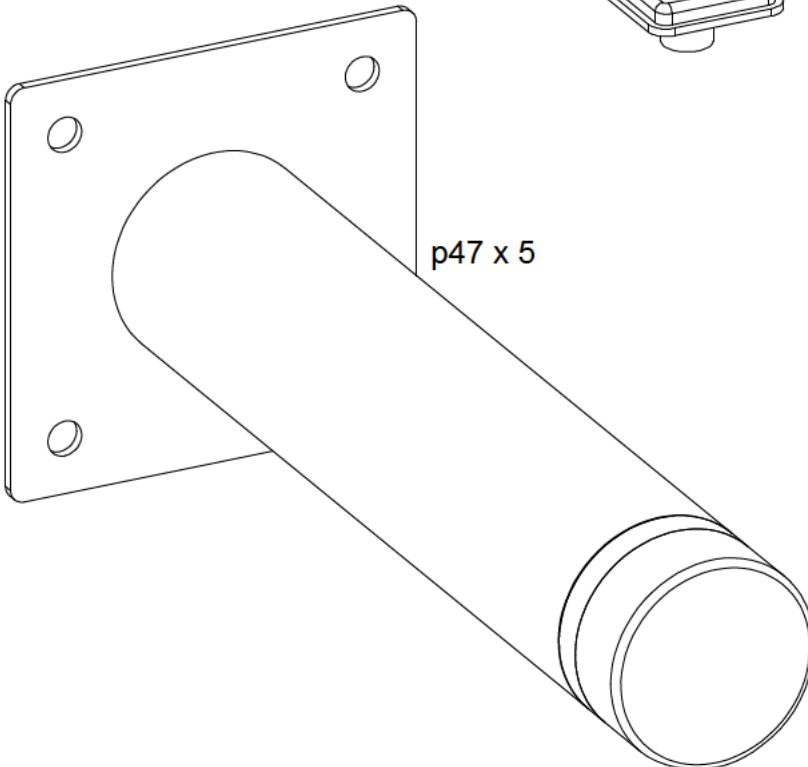

p47 x 5

BOX 1	
BOX 2	✓

A

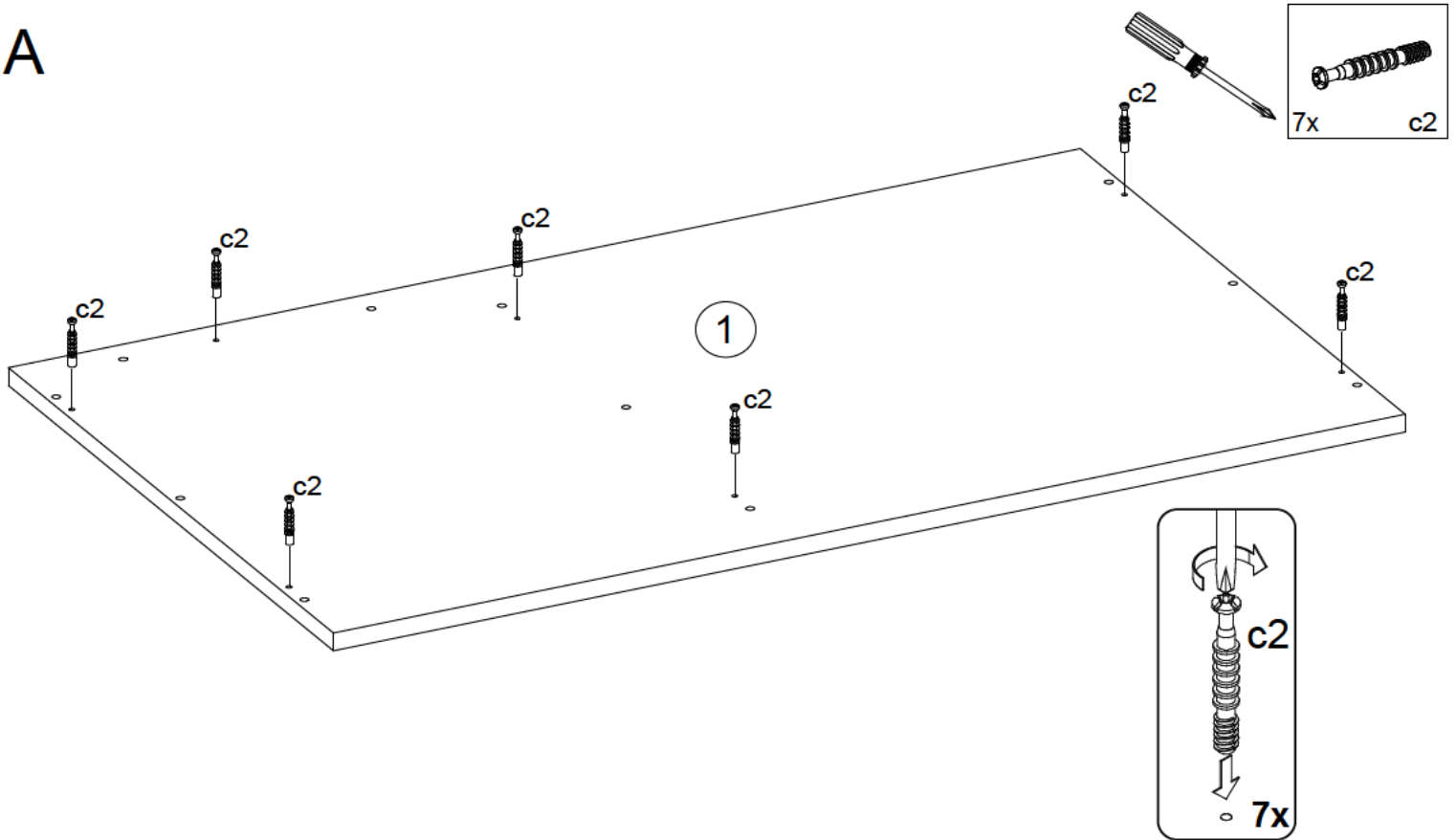

B

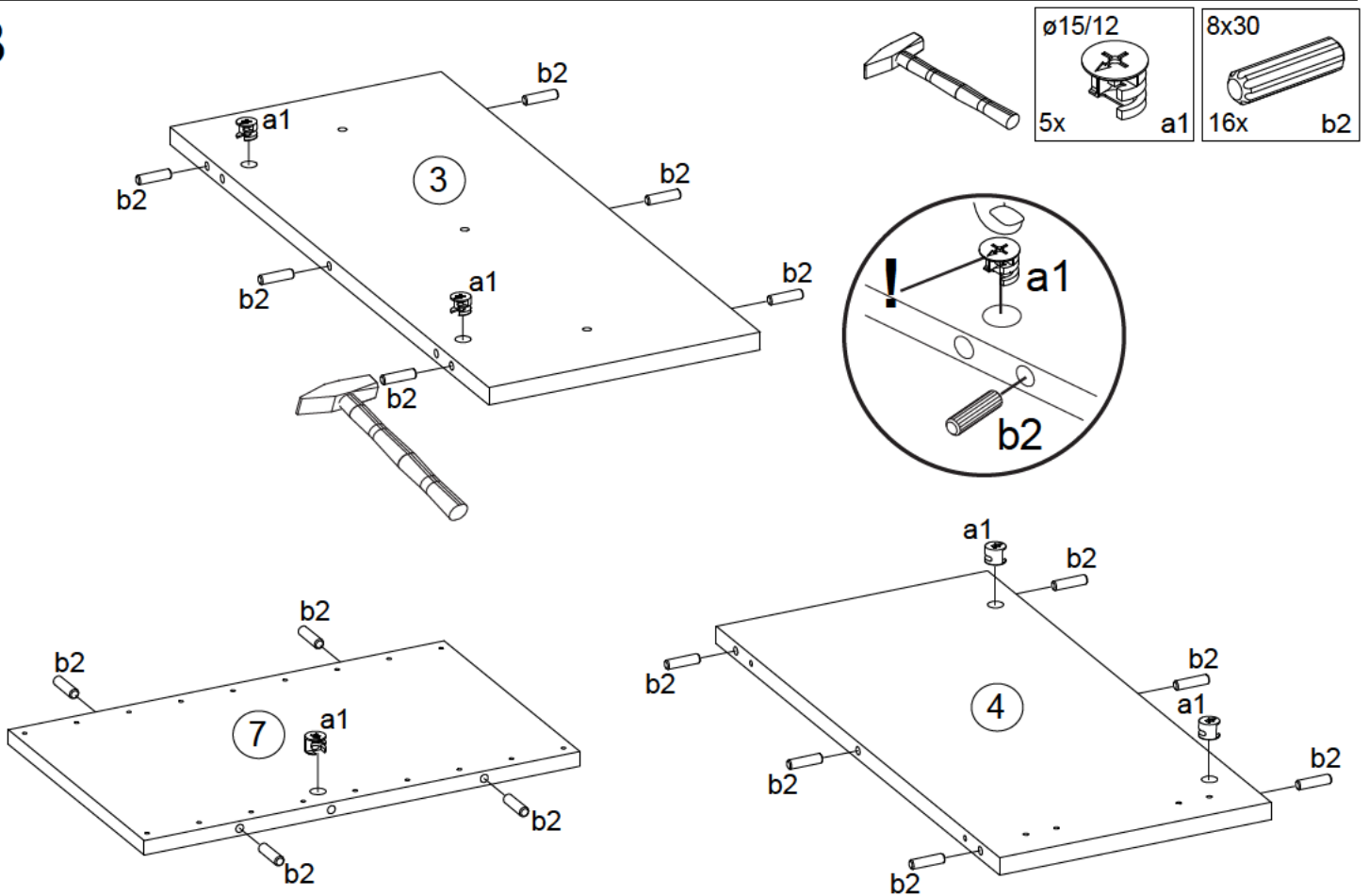

C

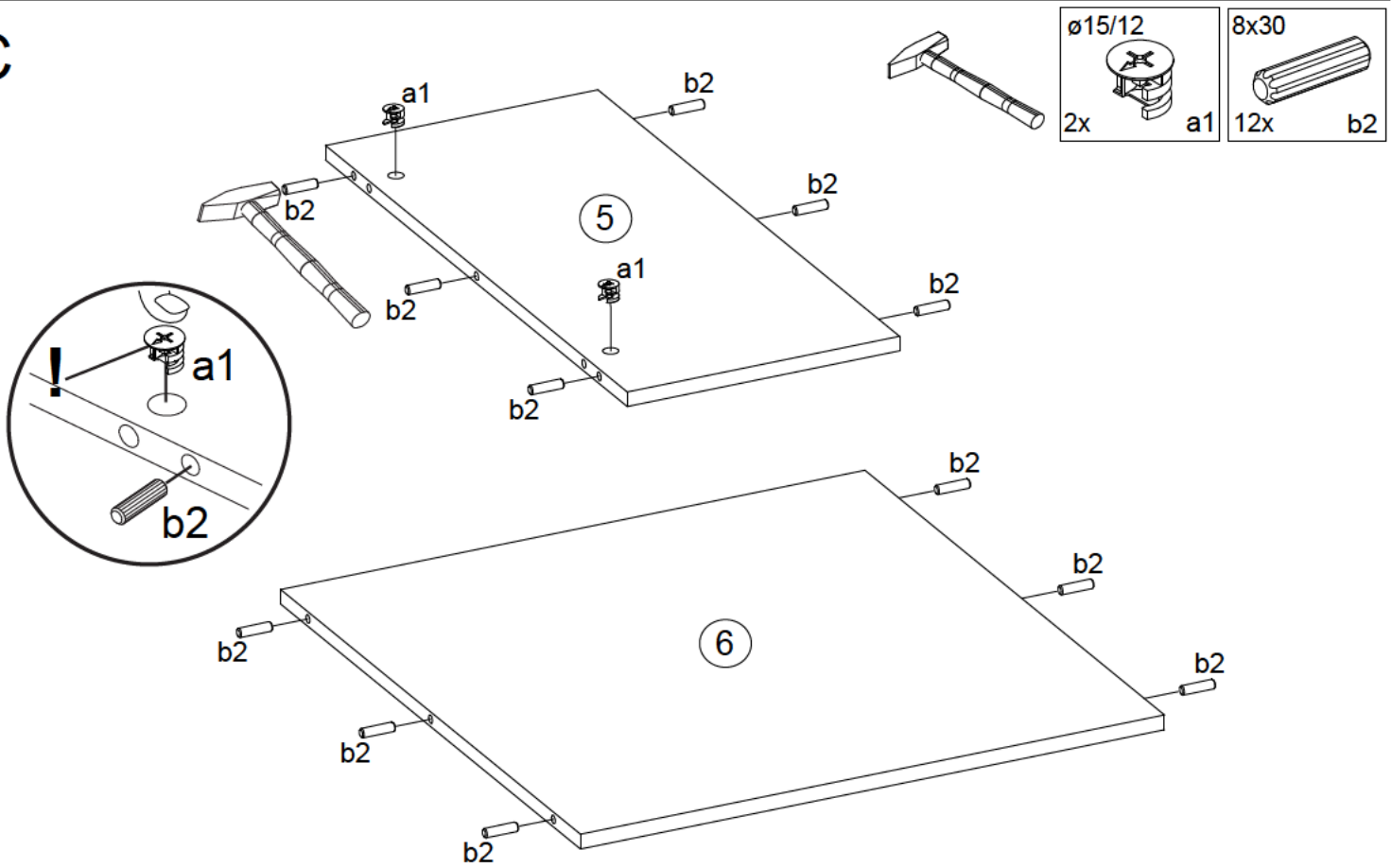

D

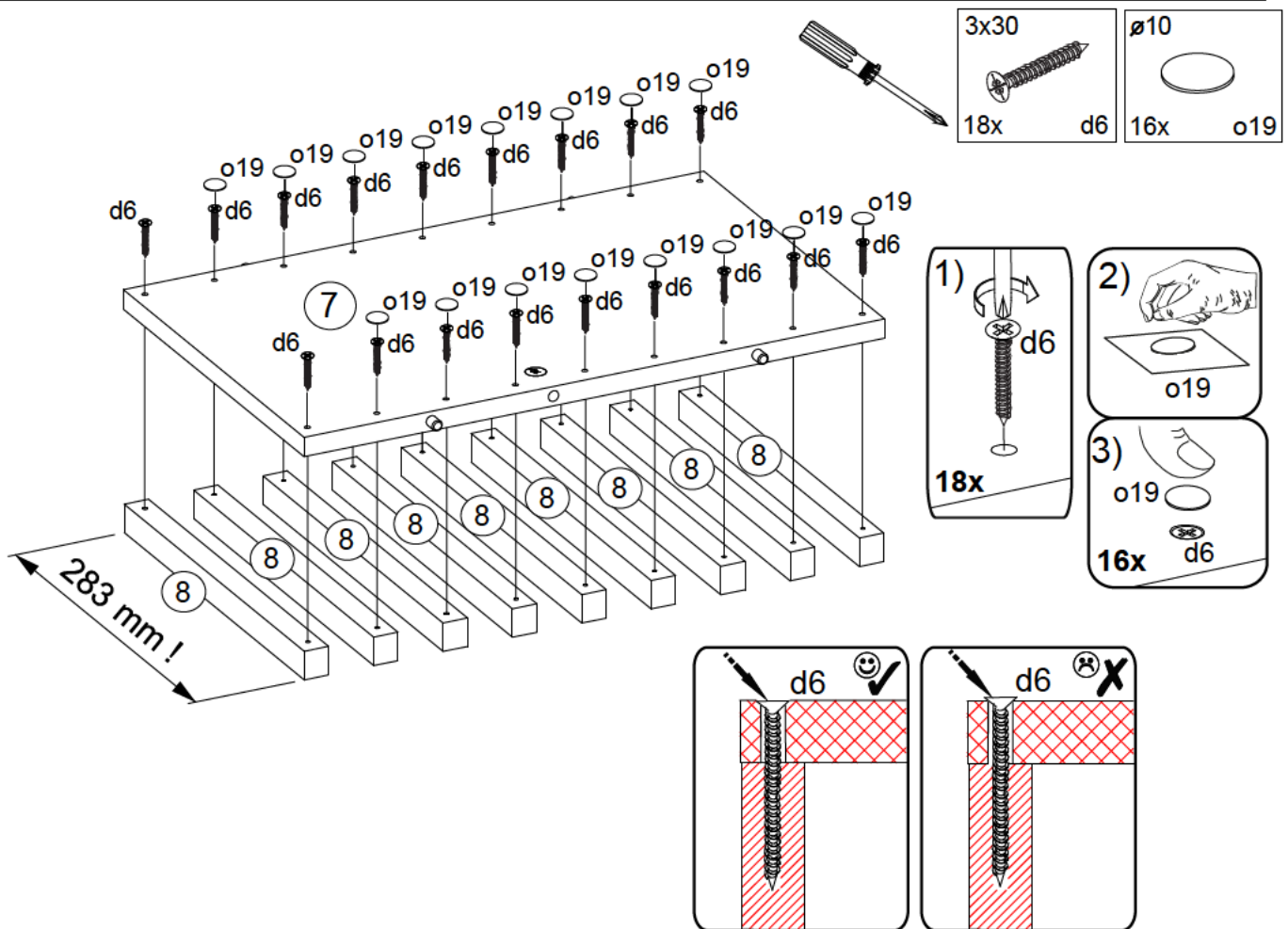

E

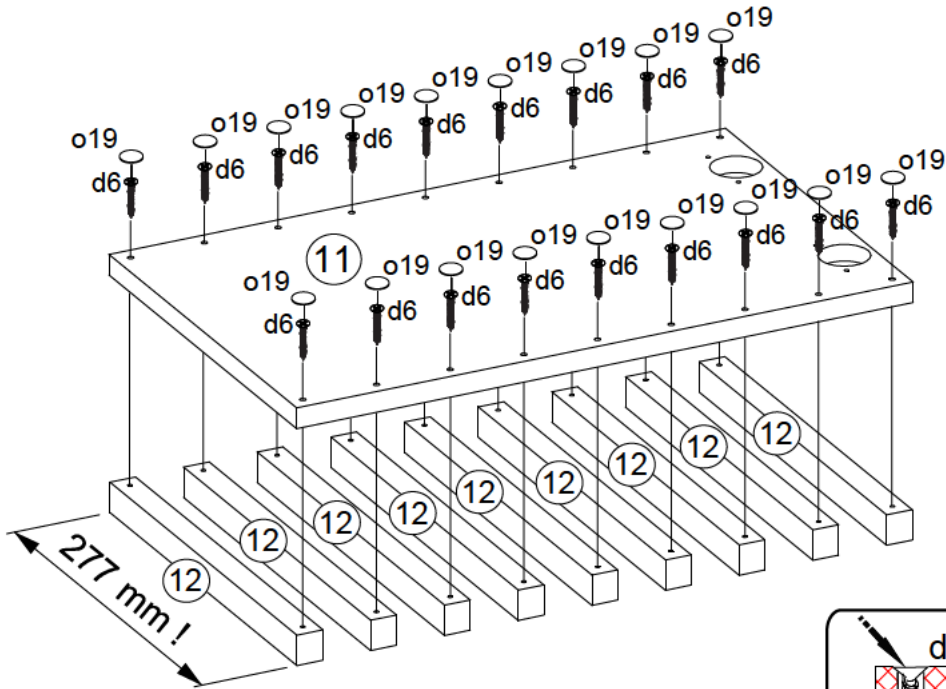

3x30



ø10

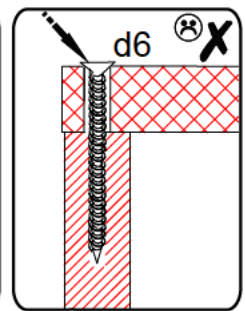
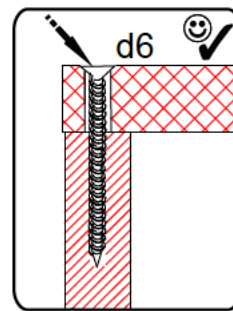
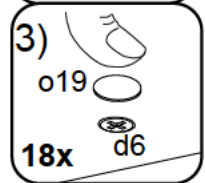
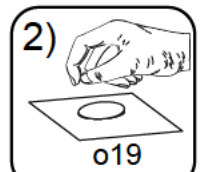
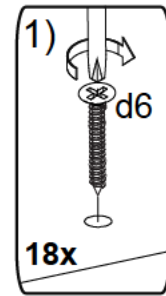
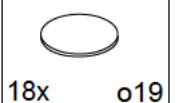

F

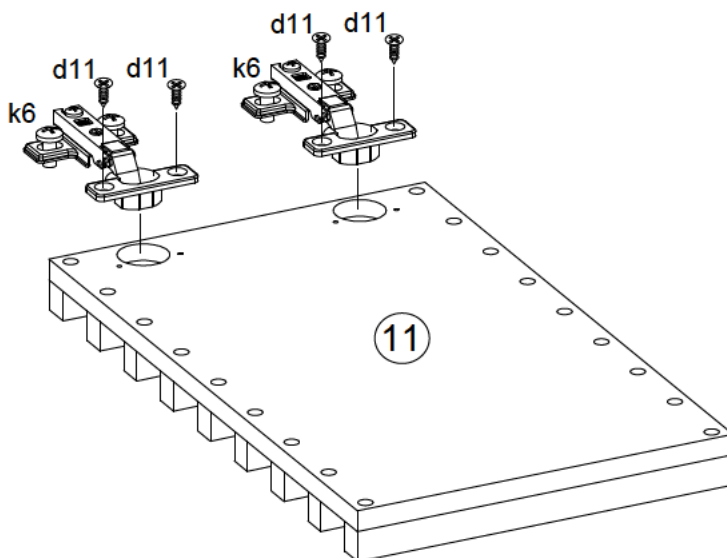

3,5x15

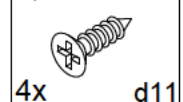

ø35

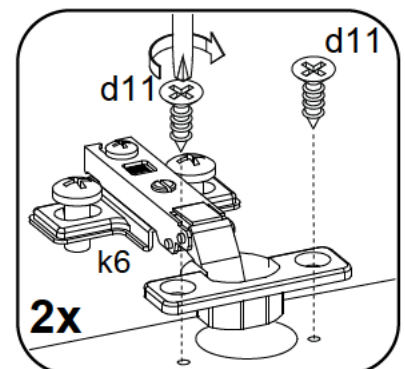
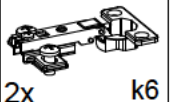

G

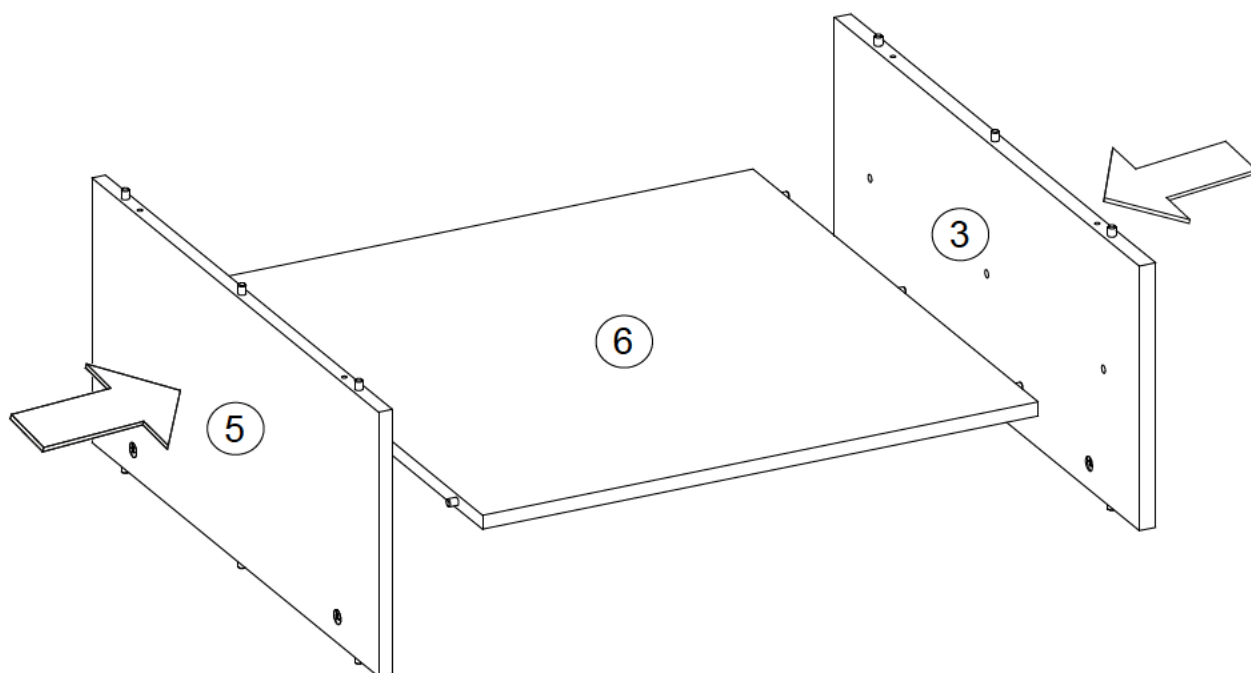

H

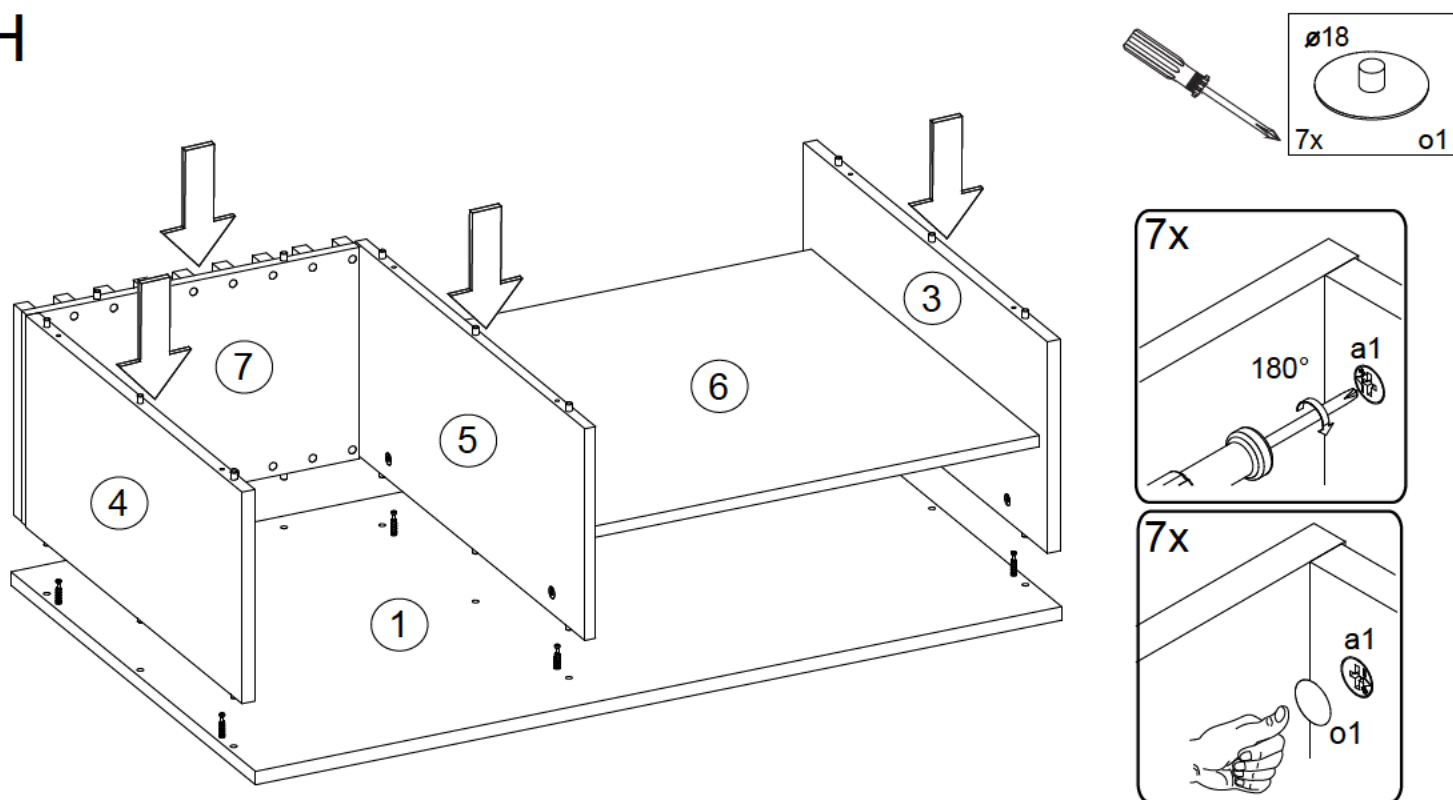

I

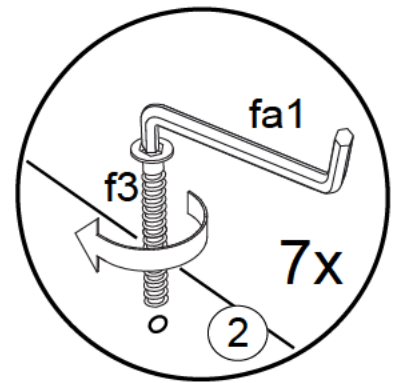
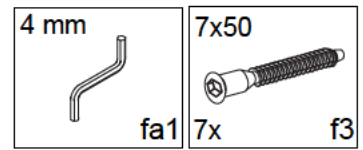
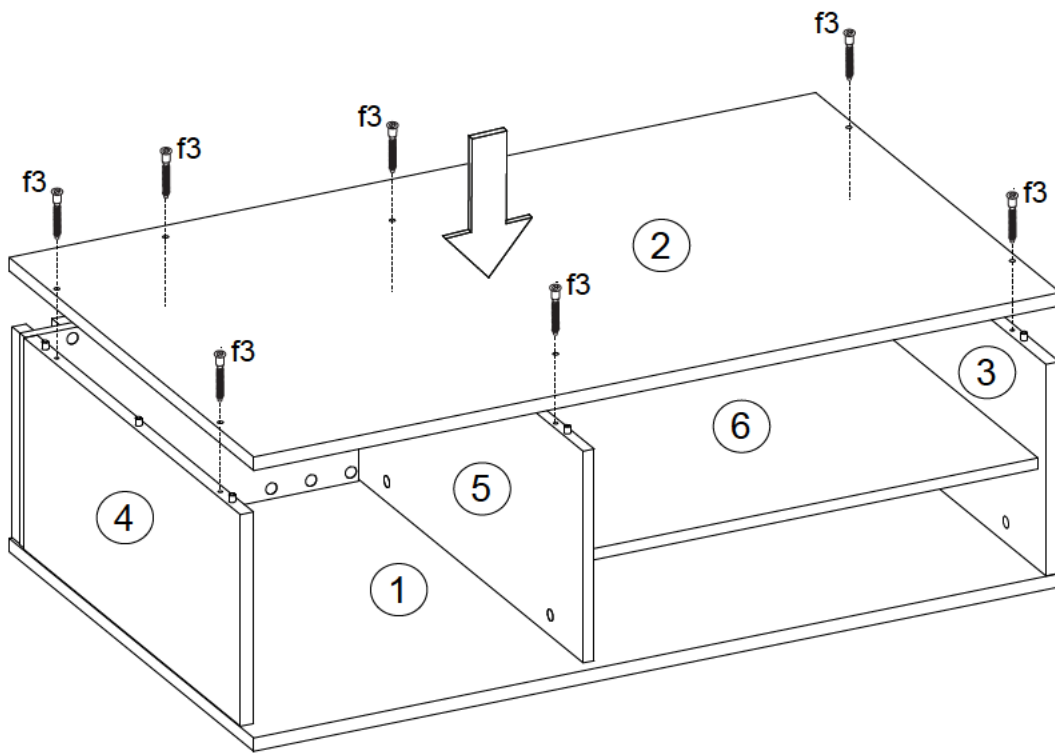

J

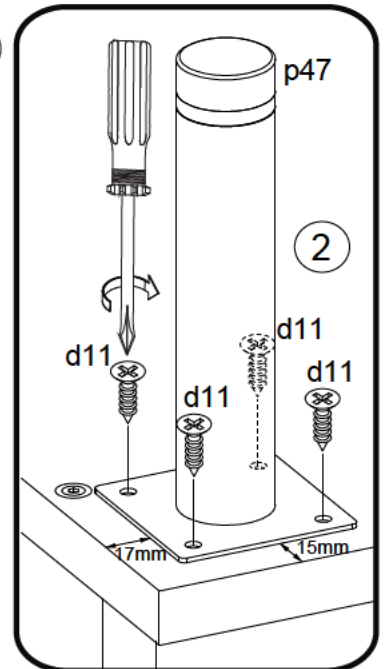
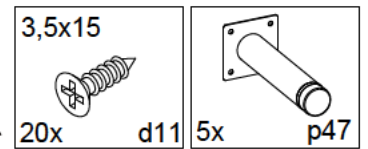
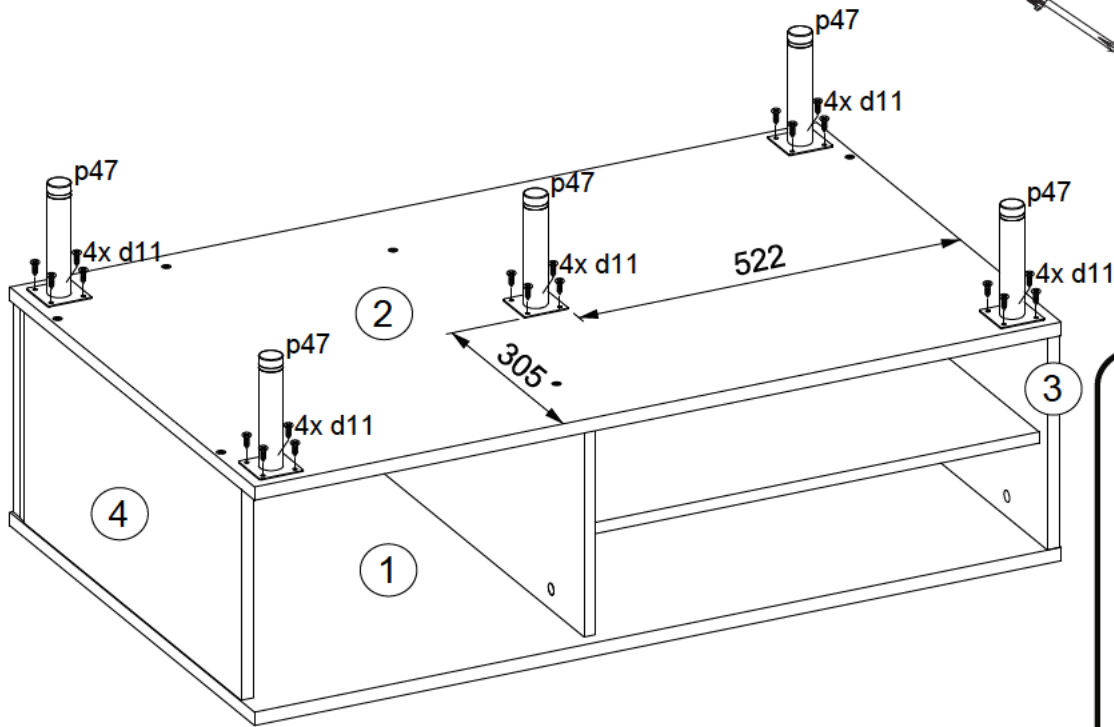

K

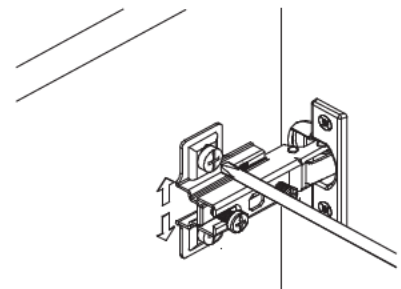
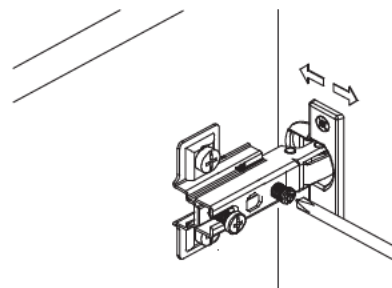
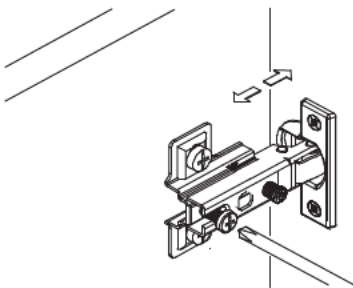
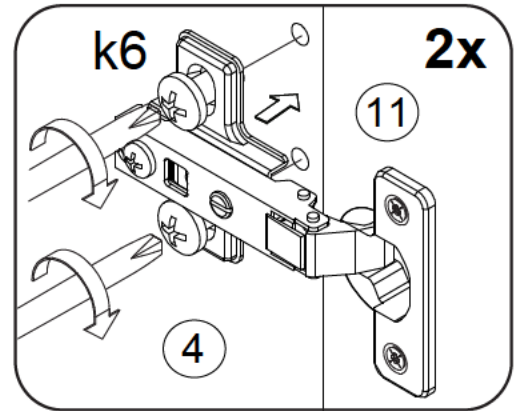
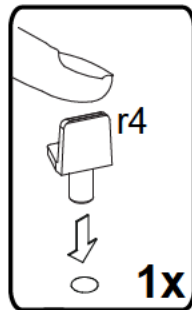
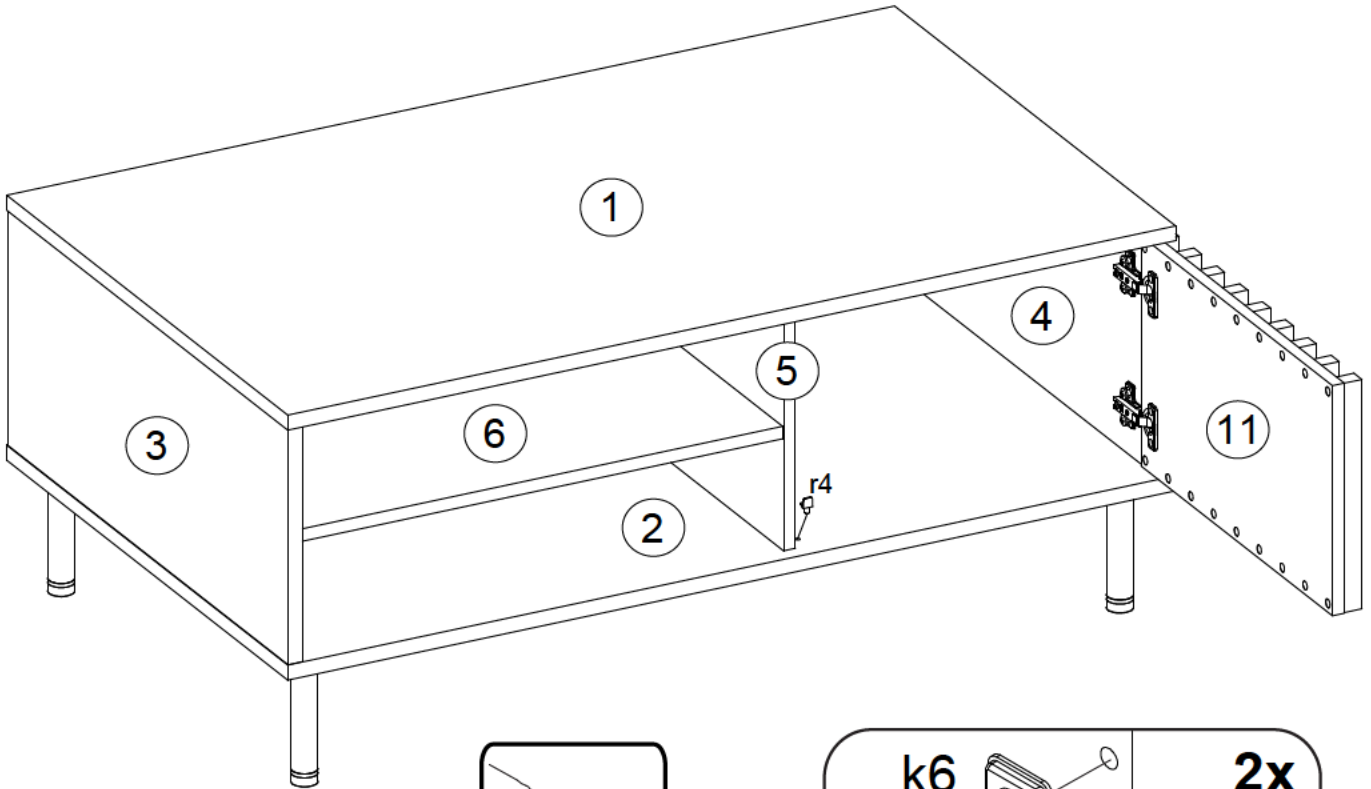
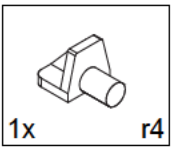



- Ⓓ Das Möbel muss an der Wand befestigt werden!
- Ⓔ Please ensure to mount the furniture to the wall!
- Ⓕ Les meubles doivent être fixés au mur!
- Ⓝ Het meubel moet aan de wand worden vastgemaakt!
- Ⓔ El mueble se tiene que fijar a la pared!
- Ⓕ Mebel należy przymocować do ściany!



- Ⓓ Informieren Sie sich vor der Wandmontage über das geeignete Montagematerial!
- Ⓔ Please get informed on suitable assembly materials before commencing the wall-mounting!
- Ⓕ Renseignez-vous sur le matériel de montage approprié avant le montage mural!
- Ⓝ Informeer u voor de wandmontage over het geschikte montagemateriaal!
- Ⓔ Infórmese antes del montaje en la pared del material apropiado de montaje!
- Ⓕ Przed montażem na ścianie upewnij się, jaki jest potrzebny właściwy materiał montażowy!



- Ⓓ Beschaffen Sie sich das angemessene Material zur Wandbefestigung!
- Ⓔ Please obtain suitable wall-mounting materials!
- Ⓕ Procurez-vous le matériel approprié pour le montage mural!
- Ⓝ Verschaf u het adequate materiaal voor de wandbevestiging!
- Ⓔ Procúrese el material adecuado para la fijación a la pared!
- Ⓕ Zakup odpowiedni materiał do przymocowania na ścianie!



- Ⓓ Lassen Sie die Wandbefestigung von einer fachkundigen Person vornehmen!
- Ⓔ Ensure all wall-mounting is carried out by competent personnel!
- Ⓕ Faites effectuer le montage mural par une personne compétente!
- Ⓝ Laat de wandbevestiging door een professional uitvoeren!
- Ⓔ Deje que la fijación a la pared la haga un profesional!
- Ⓕ Zleć przymocowanie do ściany odpowiednio doświadczonej osobie!

- Ⓔ Мебель должна крепиться к стене!
- Ⓓ Il mobile deve essere fissato alla parete!
- Ⓕ A bútor a falon rögzítendő!
- Ⓓ O móvel tem que ser fixado na parede!
- Ⓕ Nábytek musí být připevněn ke stěně!
- Ⓓ Montáž na stenu zverte kvalifikovanej osobe!

- Ⓓ Перед тем, как крепить мебель к стене, получите информацию о подходящем крепежном материале!
- Ⓓ Prima del fissaggio alla parete, informarsi sul materiale di montaggio adatto!
- Ⓕ A falra szerelés előtt tájékozódjon, hogy ehhez milyen szerelőanyagok szükségesek!
- Ⓓ Antes da montagem na parede, informe-se sobre o material de montagem adequado!
- Ⓕ Informujte se o vhodném montážním materiálu před montáží na stěnu!
- Ⓓ Pred montážou na stenu sa informujte o vhodnom montážnom materiáli!

- Ⓓ Приобретите соответствующий материал для крепления к стене!
- Ⓓ Procurarsi il materiale opportuno per il fissaggio alla parete!
- Ⓕ Szerezze be a falra szereléshez szükséges, megfelelő anyagokat!
- Ⓓ Obtenha o material adequado para a montagem na parede!
- Ⓕ Opatíte si vhodný materiál pro montáž na stěnu!
- Ⓓ Zabezpečte si vhodný materiál na montáž na stenu!

- Ⓓ Поручите выполнение работ по креплению к стене специалисту!
- Ⓓ Far effettuare il fissaggio alla parete ad un esperto!
- Ⓕ A bútor falra rögzítését végeztesse ehhez értő személlyel!
- Ⓓ A montagem na parede deve ser executada por uma pessoa competente!
- Ⓕ Montáž na stěnu nechte provést odborně způsobilou osobou!
- Ⓓ Montáž na stenu zverte kvalifikovanej osobe!

