

INSTRUCTION MANUAL

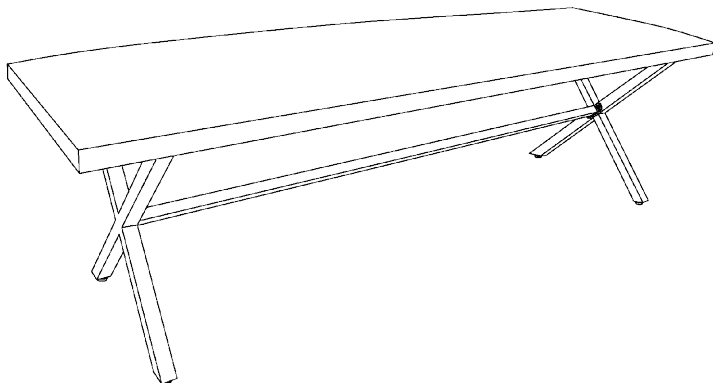

Outdoor Wicker Dining Bench

IF YOU PURCHASED THE BENCH ONLINE
AND HAVE ANY QUESTION BENCH CONCERNS

CONTACT US VIA EMAIL, OR PHONE

Email: service2outdoor@gmail.com

TEXT(SMS ONLY): +1 628-263-4608

PHONE: +1877-561-6450

Date of Manufacture: 25W20

Warnings and Cautions

Thank you for choosing our furniture. Please read and understand this entire manual before attempting to assemble or install the product.

GENERAL BESTPRACTICES FOR ASSEMBLY

1. Familiarize yourself with the product and check all parts against the packing list. If any parts are missing or damaged, do not install. Contact us immediately.
2. Some parts may contain sharp edges. Wear protective gloves if necessary, during assembly.
3. Check all nuts and bolts periodically for tightness and, when required, tighten them again.
4. Pay attention to the parts orientation.
5. Save all packing materials until assembly is complete to avoid accidentally discarding smaller parts or hardware.

IMPORTANT

- And take care to place the washer on the screw before placing the screw in the screw hole.
- In order to adjust the entire product to the best condition, Loosely assemble before tightening.
- Tighten all screws after all parts are assembled.

WARNINGS

 **Keep children and pets away from the working area during assembly and adjustments.**

1. Keep assembly area at least 6 feet from any obstruction such as a fence, garage, house, overhanging branches, laundry line or electrical wires.
2. When assembling and using this product, basic safety precautions should always be followed to reduce the risk of personal injury and damage to the product. Please read all instructions before assembly and use.
3. Check all bolts for tightness before use. **IMPORTANT** - check and tighten bolts often to keep them secure!
4. The product is not to be used for standing purposes and will not function as a stool or step-ladder. Use on even surfaces only.
5. The bench use at weight of 500lb (227kg). Improper use of this product or failure to use as directed may result in injury. Not intended for commercial use.

WARRANTY

• WHAT IS COVERED?

- The limited warranty is extended to the original purchaser and applies to material and manufacturer's defect provided the item is maintained with care and used only for personal residential purposes.
- Warranty: 1 Year
- Lost Accessories or Parts Policy : Lost accessories or parts costs will be incurred after 90 days of the date of purchase.

MAINTENANCE

- **STAIN RESISTANT CUSHIONS CARE:** Keep cushions in storage on rainy days.
- **SPILLS:** Immediately wipe up spills using a white damp cloth. Repeat if necessary until the stain is gone. Allow cushions to air dry.
- **FABRIC CARE:** Hand wash cold, non-chlorine bleach when needed, lay flat to dry. Cool iron if necessary. Do not dry clean.
- **RESIN WICKER PRODUCT CARE:**
 - 1. General Cleaning: Before using, clean the product completely with a soft, dry towel. When not in use, wipe off any dirt or loose objects. Use a mild soap and water solution for regular cleaning, rinse thoroughly, and dry completely.
 - 2. Weather Protection: To prolong the life of your resin wicker, avoid prolonged exposure to intense sunlight or heavy rain. Whenever possible, use a protective cover when the furniture is not in use, especially during extreme weather conditions.
 - 3. Avoid Harsh Cleaners: Do not use strong detergents or abrasive cleaners, as these may damage the finish.

Regular Maintenance: Over time, nuts and bolts may loosen. Occasionally check and re-tighten nuts and bolts on all chairs and tables if necessary.

Tools Needed (Not Included)



Pistol Drill





1 People



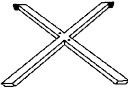

APPROXIMATELY
45 MIN.
ASSEMBLY

PARTS LIST

CODE	DESC	PARTS	QTY
A	Bench Top		x1
B	Bench Leg		x2
C	Leg Support		x1

HARDWARE LIST

CODE	DESC	PARTS	QTY
D	Bolt	 M5*15	x8
E	Washer	 M6	x8
F	Allen Key	 4*4	x1

Note: Do not tighten the screws during the assembly process. Wait until all the components are assembled before tightening all the assembly.

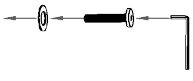

STEP1

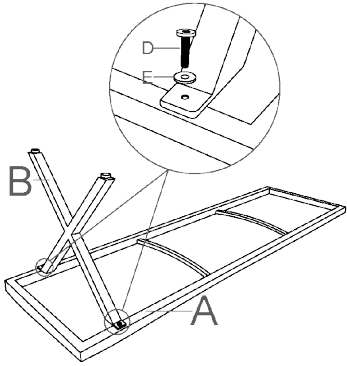

STEP2

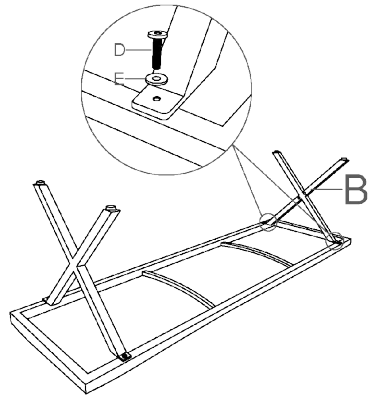

STEP3

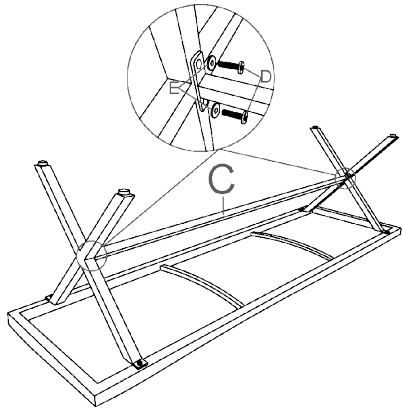

Note: After tightening all the screws, you can start using the product now.

