

✉ Email: [Service@veloinno.com](mailto:Service@veloinno.com)

☎ Tel: (213) 902 6881

# Vivago

---

GUIDE BOOK&USER MANUAL



# FOR YOUR SAFETY, PLEASE WEAR THE HELMET CORRECTLY!

Please make sure the helmet covered your head completely as below.

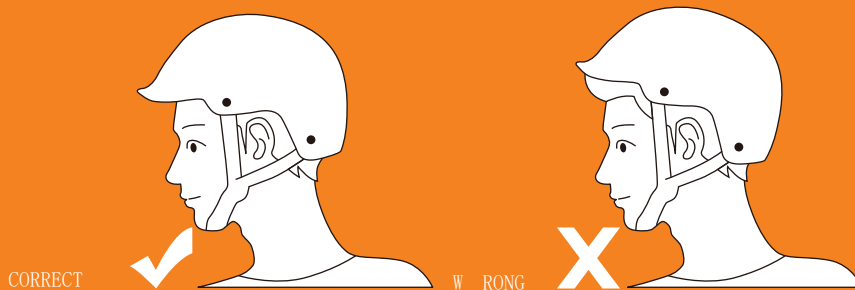

## Technical specification

Item	Parameter	Item	Parameter
L*W*H (mm)	1310*575*970	grade ability	$\leq 15^\circ$
ground clearance (mm)	50	max speed (km/h)	$13 \pm 1$
weight (kg)	61	range (km)	$\geq 65$
load(1 rider)	75	charging time	8-12
rated power	350W	tire	3.50-6
battery	48V20Ah		

\*The data come from the corporate laboratory tests in ideal conditions and all data are for reference only.

# Instrument Operating Instructions

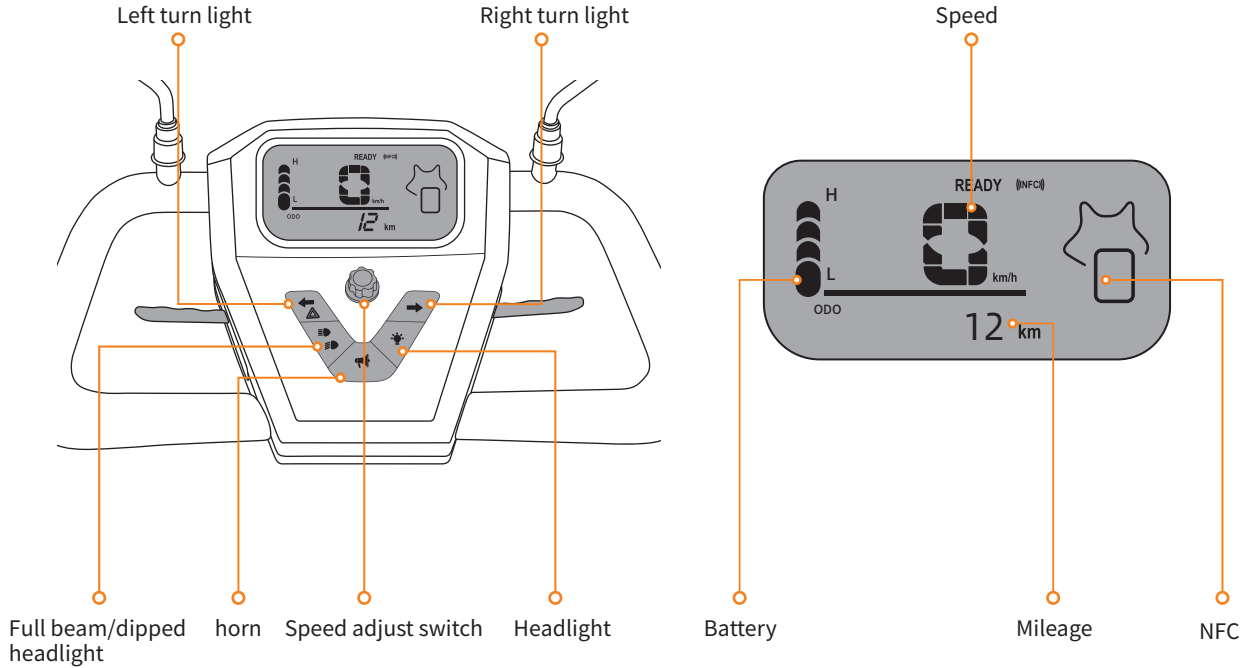

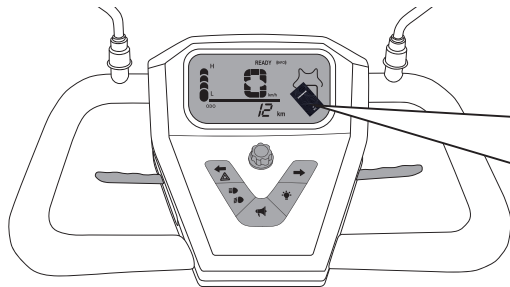

Put NFC card on the instrument to start the vehicle

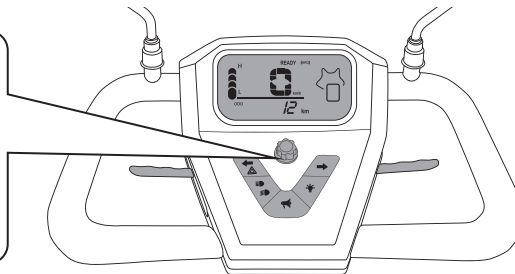
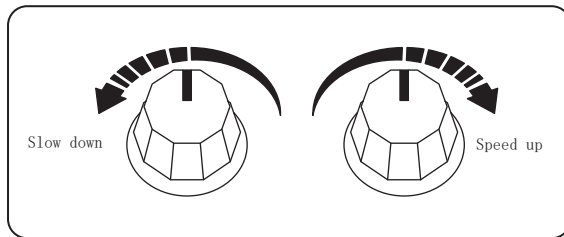

**⚠ Attention**

When riding for the first time, it is recommended to operate at a lower speed to prevent high-speed and unskilled riding, which may lead to accidents.

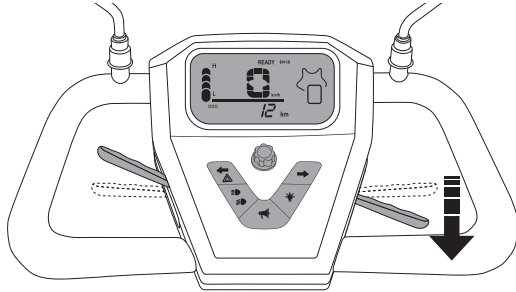

### Forward

Gently hold the right lever to move the vehicle forward; released the lever smoothly to stop.

### Reversing

Gently hold the left lever to reverse the vehicle; released vehicle; released the lever smoothly to stop.

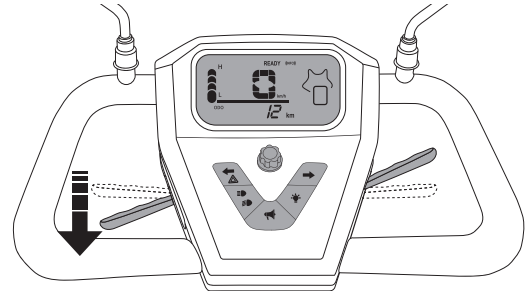

## Electromagnetic brake switch operating instructions

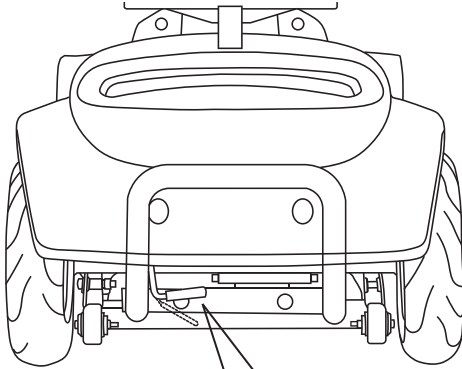

D (ON):  
Can drive, can not move manually.  
N (OFF):  
Not driving, can be moved manually.

### Attention

It is forbidden to switch OFF during driving.  
If you need to move the scooter, please  
switch to N and move manually.

## Seat Operating Instructions

### 1. Armrest adjustment

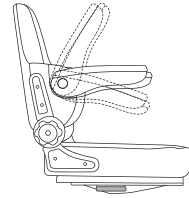
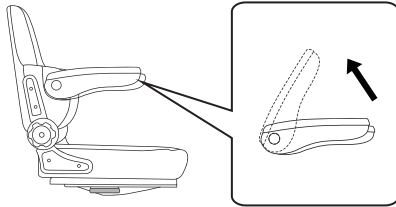

### 2. Move seat back and forward

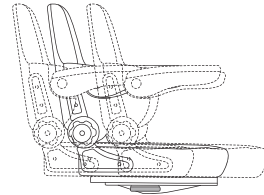
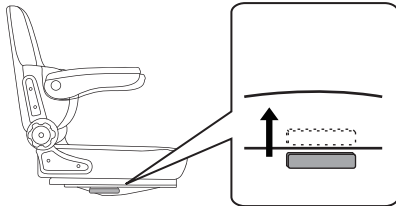

### 3. Adjust backrest

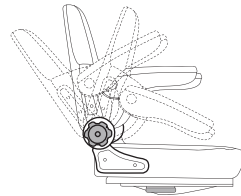
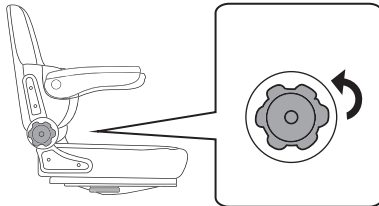

## Use and Maintenance

- The vehicle use precautions.

1. Place the NFC card on the instrument screen. At this time, the power supply and power display light on the instrument screen are on, indicating that the vehicle has been started.
2. Please drive on the non-motorized vehicle lane at low speed.
3. After parking for a long time, please move the gear handle back and forth to the required gear, and then start the vehicle.
4. Before the vehicle is started, please pay attention to the output power display. When the vehicle is operated to start, please pull the start lever backward slowly at an even speed with your right hand. When operating the vehicle backwards, please adjust the output power to the lowest speed. When starting, please pull the start lever backward slowly at an even speed with your left hand.

- Note for the use of motor and controller.

1. When driving against the wind or climbing, do not accelerate rapidly, but should accelerate evenly and gradually to avoid excessive load on the motor and battery.
2. In the rainy season, the vehicle should avoid from the center line of the rear wheel, to avoid the motor and battery damp, burn the motor.
3. When driving, should avoid operate the speed control and brake at the same time, so as not to overload the motor and damage to other parts.
4. The vehicle is not adapt to uneven or steep road driving, if the vibration is large, will cause poor contact with electrical parts, if to this road, please try to slow down as well.

### **! Warning:**

- 1. Do not instantly accelerate the speed, to ensure the safety of driving, while protecting the motor, battery.**
- 2. The vehicle with differential rear axle motor, the differential for gear combination needs gear oil lubrication, usually called gearbox, in normal driving conditions should be changed gear oil every 3 months.**

#### ● Precautions for use of battery

##### 1. Technical feature:

At present, the commonly used battery is "sealed maintainable lead-acid battery" as the energy storage component of leisure vehicles, with large capacity, long life and good maintainability.

##### 2. Battery is a consumable:

Battery is equivalent to the "fuel tank" in the car, is the place to store energy, but it is different from the "fuel tank" lies in: its "volume" will decrease with the depth of use, in this sense, battery belongs to consumables. And this "reduction" "decline" speed is different, the choice of high quality battery, the correct use of battery, good car condition, especially the use of high efficiency motor will effectively delay the decline of battery capacity.

##### 3. Correct use of the battery, precautions:

! Always put the battery in a sufficient power state. Lead acid battery should be replenished in time, which is beneficial to prolong the life of the battery. If the battery is not used for a long time, please be sure to keep the battery in a state of sufficient power, and charge once a month, it is strictly prohibited to "lose power" storage. ! Pay attention to check whether the temperature on the surface of the

**!! After driving in summer, because the battery temperature is high, it should not be charged immediately. In winter, the battery is below 0°C Celsius, the battery is at low temperature, and the charging should be carried out indoors.**

• Note: There are three main ways to maintain sufficient range driving capacity

1. As far as possible to drive at a low speed, the working current and speed of the electric vehicle into a nonlinear rise relationship, the endurance and driving speed is inversely proportional, the battery life and driving speed is inversely proportional, that is to say, maintaining good low speed driving habits for extending the battery use time has great benefits.

2. As far as possible to maintain the use of "frequent charging" habits, to prevent the battery from often working in the "undervoltage" state, but also to reduce the probability of power loss.

3. The electric vehicles with low speed gear, try to use low speed gear. With low speed when driving, driving ability is strong.

• Charger and charging precautions

1. Characteristics of the charging technology

Charger internal using high-tech CPU chip, equipped with electric bicycle / electric vehicle battery charging mode optimization program, using the random process control theory, the battery surplus uncertain, after charging disconnected power time is uncertain, each time must be full of uncertain under the actual use of the optimal charging mode. In this intelligent charging mode, combined with battery maintenance technology, the online maintenance function can be realized without the intervention of the user, and the battery can be reduced or not used for a long time automatically repaired to the best state.

battery box when charging the battery, and whether the charger indicator is changed to "red" and "green". If it cannot be converted, please immediately cut off the power supply and send the charger and the battery to the maintenance center for inspection.

! At low temperature (below 15°C) conditions, the battery is easy to decline by 20%~30%, and the corresponding range will also be reduced.

! When replacing the internal battery of the battery pack, it is strictly prohibited to mix the battery with different performance parameters, otherwise the battery will cause damage.

! Battery shall not contact the flame, heat source and alkaline substances, avoid direct sunlight exposure, otherwise it will shorten the battery life.

Pay attention to:

! In the area of unstable grid voltage, when the grid voltage fluctuation exceeds  $AC220V \pm 20\%$ , otherwise it is easy to cause the charger to undercharge the battery or the charger to fail.

! This recharger does not need to be grounded.

1. Open the charging port

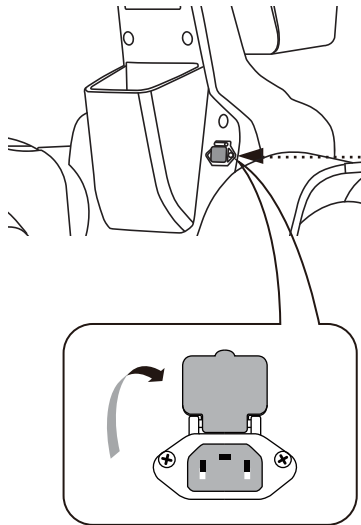

2. Charging

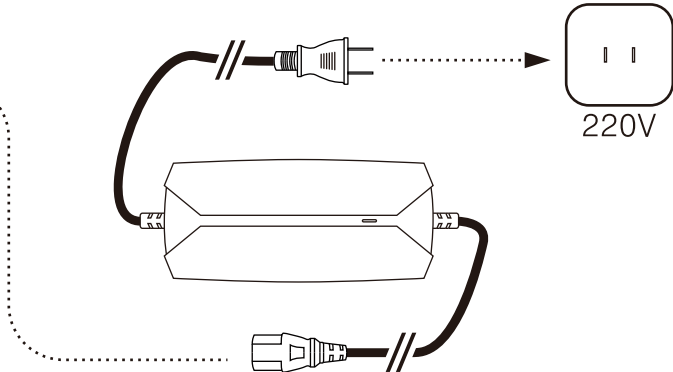

## 2. Charging method

The charger indicator is "green" when the battery is filled in the floating charge state, there is no need to cut off the power if there is an emergency, the indicator is "orange" can also be used. When you charge the battery of the scooter, do not close the main switch. plug the charger output plug into the socket on the vehicle body, and then insert the charger input power plug into the AV220V power socket.

## 3. Charging instructions

Charger in power to charge the battery, charging indicator display red state, said that the battery is in the charger into constant current charging state, when the orange indicator, the battery has charged into 90%, when the green and orange lights alternately, about an hour after the green battery capacity, 100% full, if continue to charge, online maintenance, maintain or restore capacity, maintenance after continue, the charger into the battery micro current supplement, if still continue to charge the battery, and back to the online maintenance stage.

! When charging, it is strictly prohibited to cover other items on the charger and battery box to facilitate ventilation and heat dissipation.

! When carrying the charger, do not bump violently or collide, otherwise it is easy to cause damage.

## 4. Other important precautions

When used and stored, liquid and metal chips should be prevented from penetrating into the charger to prevent short circuit in damaging the charger.

! When used and stored, liquid and metal chips should be prevented from penetrating into the charger to prevent short circuit and damaging the charger. The charger will generate some heat at the bottom of the charger to prevent flammable and explosive items, such as flammable plastic or foam; the top and sides of the charger; please use the charger in a well-ventilated environment. If you smell the odor during the charging process or find that the external temperature of the charger is too high (the surface temperature of the shell is higher than 65°C), please stop charging immediately and send it to the maintenance department for inspection.

! For the online maintenance of the battery, a proper long charging time is needed, and the user can maintain the battery online at the appropriate time and cycle. The long charging effect once a week is good.

The battery products of different battery factories, in different seasons (different operating temperatures), the online maintenance charger has an adaptive function. Automatic adjust the charging voltage value, to ensure sufficient power without damage to the battery, battery capacity decline is slow, effectively prolong the working life of the battery.

• **Tip**

! When the charger fails or the battery fails, the charger indicator may not change color for a long time (generally more than 12h), the charger is always red, and the battery generates high heat. Please immediately stop charging the battery and send it to the maintenance department for inspection

! Online maintenance of the charger operation and other precautions refer to the use method content of the charger.

## Common troubleshooting

Common fault phenomenon	Troubleshooting method
Turn on the power supply, and the instrument is not displayed.	<ol style="list-style-type: none"> <li>1. Whether the key switch is opened;</li> <li>2. Whether the power plug is inserted;</li> <li>3. Whether the broken electrical switch is opened.</li> </ol>
Turn on the power supply, the controller works normally, turn the handle, but the motor does not rotate.	<ol style="list-style-type: none"> <li>1. Check whether the control line of the right hand falls off, whether the controller or motor joint falls off;</li> <li>2. The initial speed is not enough, and external assistance is needed;</li> <li>3. Whether the left and right switch bars are power off.</li> </ol>
Cycling is laborious and slow speed.	<ol style="list-style-type: none"> <li>1. Check whether the brake is locked;</li> <li>2. Whether the tire pressure is appropriate;</li> <li>3. Whether the battery voltage is sufficient, if insufficient, please charge;</li> <li>4. Whether beyond the limit ramp or headwind</li> </ol>
Short driving distance.	<ol style="list-style-type: none"> <li>1. If the battery is placed for a long time, please recharge;</li> <li>2. Whether the tire pressure is insufficient;</li> <li>3. Check whether the brake is too tight;</li> <li>4. Whether the battery charging is sufficient;</li> <li>5. Whether the battery is uphill or headwind;</li> <li>6. Whether the temperature is too low.</li> </ol>
The battery can not be charged.	<ol style="list-style-type: none"> <li>1. Check the charger and power supply, whether the battery connection is intact and reliable;</li> <li>2. Whether the external power supply is charged and the voltage is normal.</li> </ol>

## Daily inspection and adjustment

**In order to ensure driving safety, users should pay attention to the following important matters.**

- Check and adjust of the brake system:

1. Are the left and right brake bars well? Can the power supply be cut off automatically during braking?
2. When is running at a speed of 20 km/h, emergency braking should be made safely parked within 5m; if the braking distance is too long, the brake should be adjusted; if the brake pad is worn, it should be replaced in time.
3. The front and rear wheels are not power-supply switched on. Is the idling normal? Is there any friction resistance? Adjust the brake system by adjusting the jacking screw on the brake hubcap, so that the brake hand can safely hold 1 / 2 of the brake brake. Note: Different hand strength, and the 2 paragraph shall prevail.

- Inspection and adjustment of other security systems:

1. Is the front and rear tire pressure normal? If the air pressure is insufficient, it should be inflated in time.
2. Do the left and right turn signals and rear taillights work properly?
3. Whether the power-off brake is working normally ?

- Matters needing attention in driving:

1. Whether the start is smooth, whether the driving speed is suddenly fast and slow feeling.
2. The bars steering is freely, light and flexible.
3. Whether the front and rear brakes are flexible and reliable, and whether the abnormal sound is produced when the front and rear wheels rotate.

4. Turn signal, horn, headlight and rear taillight, instrument light, is work normal or not.
5. Whether the front and rear tire pressure is sufficient.
6. Whether the fastening screws, screws and nuts of the whole car are loose phenomenon.
7. Whether the free driving of the front and rear brake cable is appropriate.

**Note: If the above situation is abnormal, it should be replaced immediately.**

• Simple adjustment of the vehicle:

1. The brake hand can brake safely when it reaches 1 / 2.
2. Maintain proper tire air pressure (standard pressure: 300kpa(3.0kpa/cm<sup>2</sup>)).

## Notes for cycling

### Matters needing attention

1. Strictly abide by the rules of traffic, drive the lane in accordance with the traffic regulations
2. The rated carrier of recreational vehicles is the same as electric bicycles and bicycles, and it is strictly prohibited to drive with adults (except children).
3. The handlebars can not be hung object driving, so as not to operate out of control.
4. Driving in the rain can only wear a poncho, not with an umbrella, it is strictly prohibited to operate the vehicle with one hand;
5. When cleaning vehicles, do not clean directly with water. It is forbidden to wash with high-pressure water gun to prevent electrical damp short circuit.
6. It is strictly prohibited to overspeed downhill. At high speed, do not use one hand or brake quickly to avoid the danger of the center of gravity forward;
7. Unauthorized dismantling of the vehicle body, will bring potential safety risks to your vehicle, causing threats.
8. Before riding, we must ensure that the fasteners are safe and reliable to avoid accidents.
9. Avoid driving on uneven, muddy, gravel and steps of the road, so as to avoid tire burst, hub deformation damaged your vehicle to dangerous.

**! Note: The premise of braking distance should be increased when riding in rain or snow.**