

Assembly Instructions

Caution: You must read this before you proceed

Care & Maintenance



- Not for commercial use. For residential use only.



- Furniture may scratch floors. We recommend using furniture pads to protect your floors.



- Do not put hot items directly on furniture surface.



- Do not clean furniture with harsh cleansers or polish.



- Do not place furniture under direct sunlight.



- Do not place furniture near heating or cooling vents.



- Do not write on furniture without a padded barrier to protect the surface.



- Do not place furniture outside . For indoor use only.



- Stains may be removed with mild soap solution and damp cloth.



- Children should not climb or jump on the furniture.



- Dust and pick-up spills using a clean, non-colored, lint-free cloth.

QUEEN BED



WARNING !

STRANGGULATION HAZARD

NEVER place bed near windows where cords from blinds or drapes may strangle achild.

NEVER suspend strings over bed.

NEVER place items with astring, cord, or ribbon, such as hood strings or pacifercords, around a child's neck. These items may catch on bed parts.

ALWAYS follow assembly instructions.

Not intended for children under the age of six. INFANTS HAVE DIED FROMBECOMING ENTRAPPED IN BEDs. Openings in and between bed parts can entrapthe neck and head of a small child.

NEVER use bed for child under the age of six.

The mattress must be appropriately sized for the bed. If the mattress is undersizeddangerous gaps can exits and a person can become entrapped or entangled in the frame and suffocate

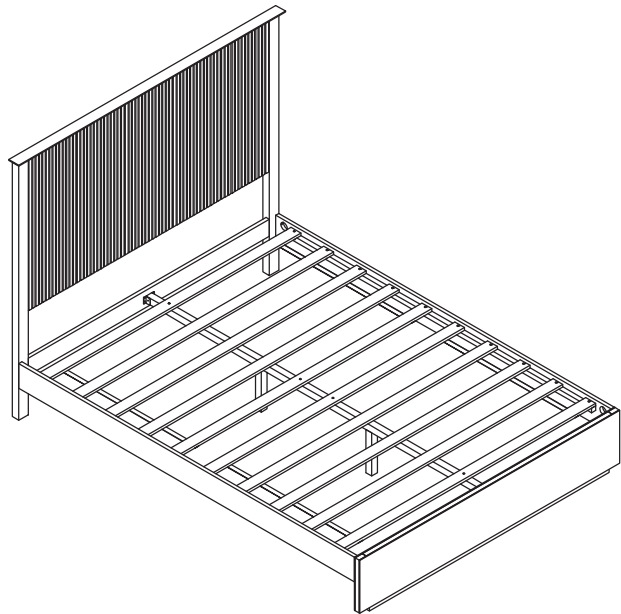











CAUTION: This Queen Bed is NOT a TOY.

Keep your child / children at bay in the process of assembly.

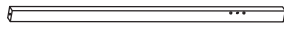
For turning the King Bed and to prevent damage to the Queen Bed.

02 persons may be needed to execute this action.

PART LIST (Hardware)

C	 Center support leg	2pcs	H	 Center rail	1pc
D	 Leg-left headboard	1pc	I	 The bar on the headboard.	1pc
E	 Leg-right headboard	1pc	J	 Headboard crossbar	1pc
F	 Vertical frame of the headboard.	2pcs	K	 The horizontal bar on the headboard.	1pc
G	 side panel	2pcs	L	 The horizontal bar under the headboard.	2pcs

PART LIST

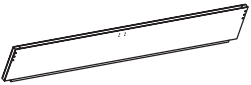
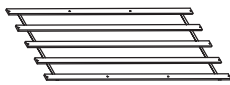
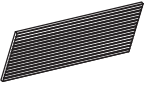
A	 Bed Frame	1pc	M	 Slats	2pcs
B	 Headboard panel	5pcs			

Hardware (Each of the above hardware including extra 1 pc)

Label	Picture	Description	Q.ty
①		Vis Ø 4 x 30mm	24+1
②		Vis Ø 4 x 15mm	12+1
③		Threaded Rod Ø5/16"x70mm)	10+1
④		Bolt Ø1/4" x 85mm	6+1
⑤		Bolt Ø5/16" x 60mm	4+1
⑥		Bolt Ø1/4" x 55mm	4+1
⑦		Bolt Ø1/4" x 35mm	15+1
⑧		Screws Ø6.3x80mm	2+1
⑨		Allen wrench	1
⑩		Wooden dowel Ø10 x 40 mm	10+1
⑪		Metal link (66x35x27mm)	2
⑫		Leveler Ø1/4 x 25 mm	2
⑬		Hex nut (M8x6mm)	10+1
⑭		Half moon washer (27x4x7mm)	10+1
⑮		Open wrench (90x12mm)	1
⑯		Screwdriver (Not provided)	1

Assembly Preparation

Overview

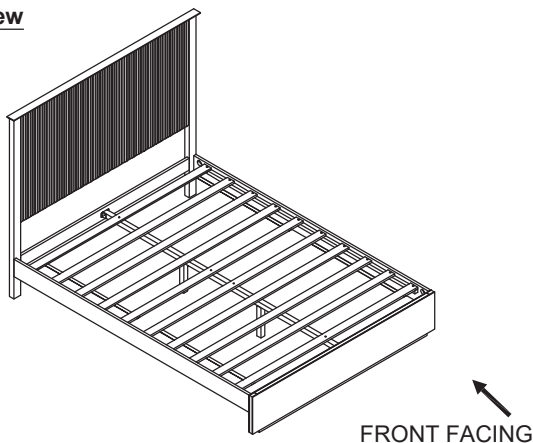

This Queen Bed has multiple parts and may require up to 1 hour to assemble. To give you an overview of the Queen Bed parts, the above picture is to help you put the various parts into perspective. Please read through the instructions herebelow to familiarise the parts and steps before assembly.

Assembly Preparation

Before Beginning Assembly

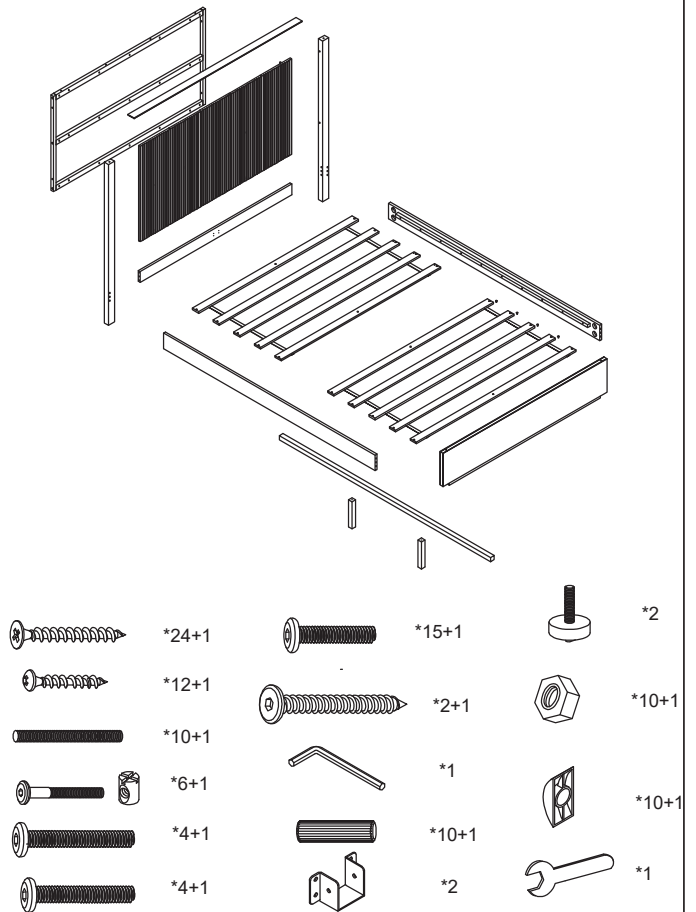

- Read instruction, cover to cover.
- Have 2 adults on hand for assembly.
- Do not assemble on flooring or carpet.
- Assemble on a clean non-marring surface (packing foam).
- Save all packaging until finished.

Step 1:

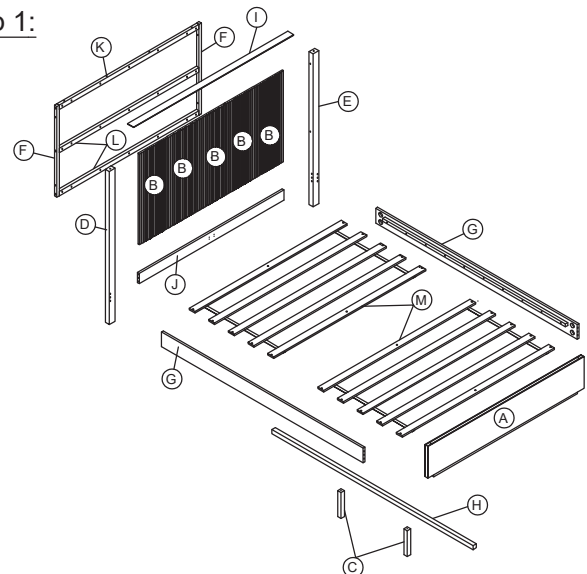

Unpack and place all part on a clean, non-marring surface.

Step 2:

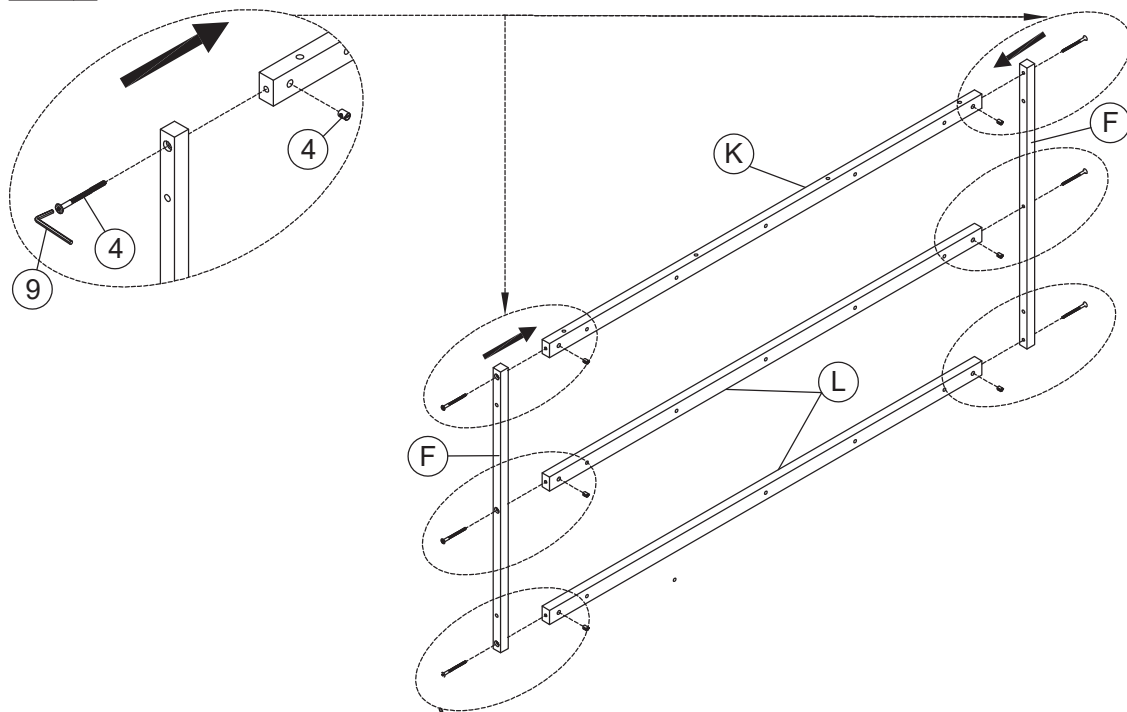

-Assemble The horizontal bar on the headboard (K), The horizontal bar under the headboard (L) to the vertical frame of the headboard (F) using bolt (4) and Allen wrench (9) as shown in the image.
Do not fully tighten the Bolts.

Step 3:

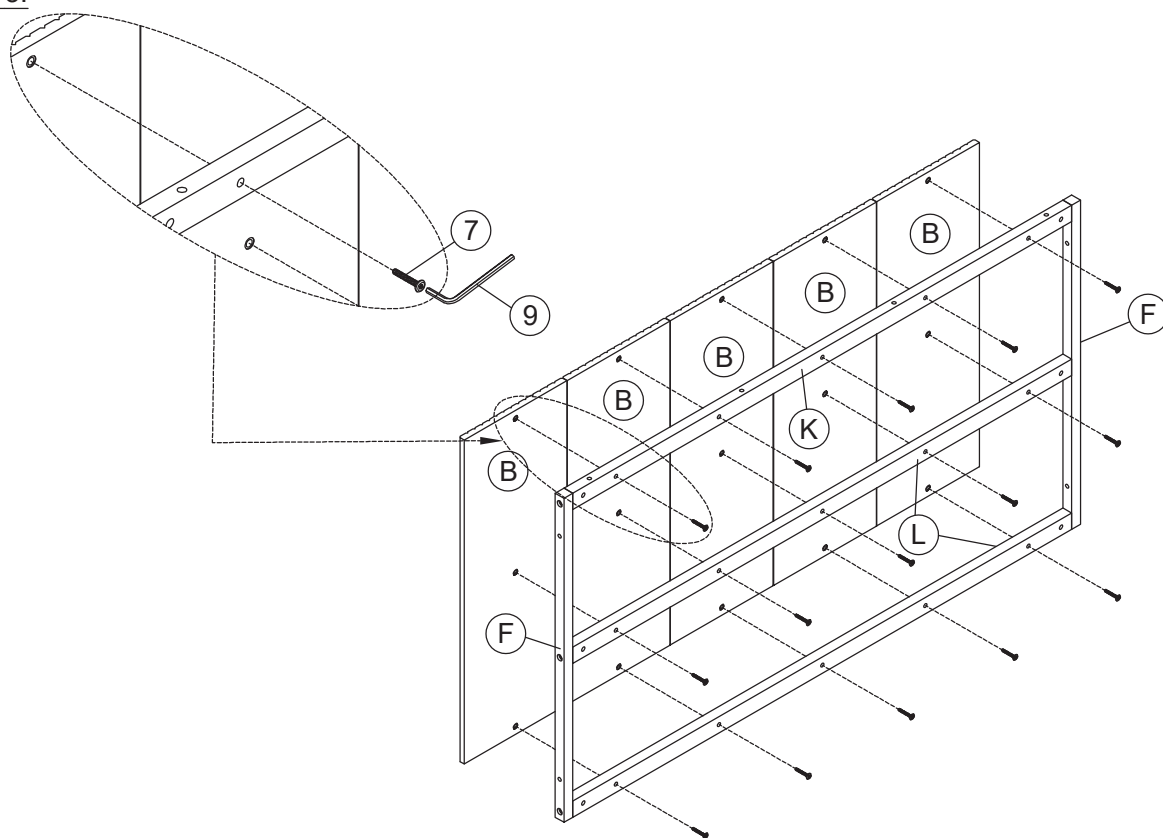

- Assemble the unit in step 2 with the Headboard panel (B) using Bolt (7) and Allen wrench (9) as shown in the image.
Do not fully tighten the Bolts.

Step 4:

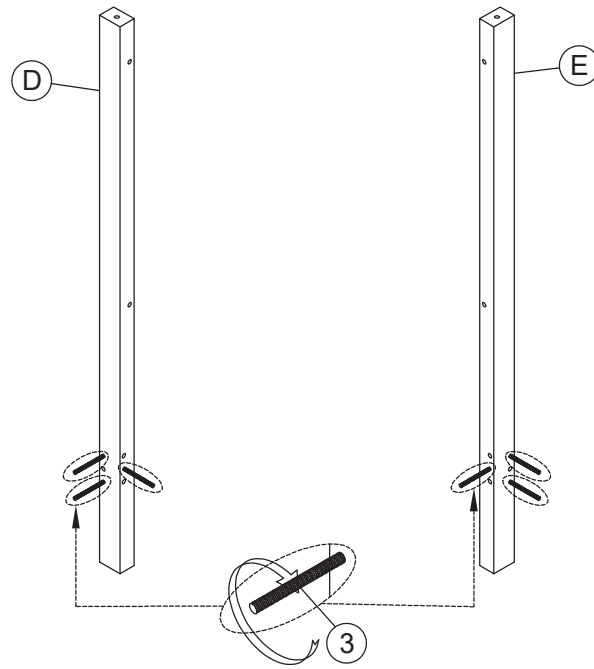

- Attach the Threaded Rod (3) to the Leg-left headboard(D) and Leg-right headboard(E) as shown in the illustration.

Do not fully tighten the Bolts.

Step 5:

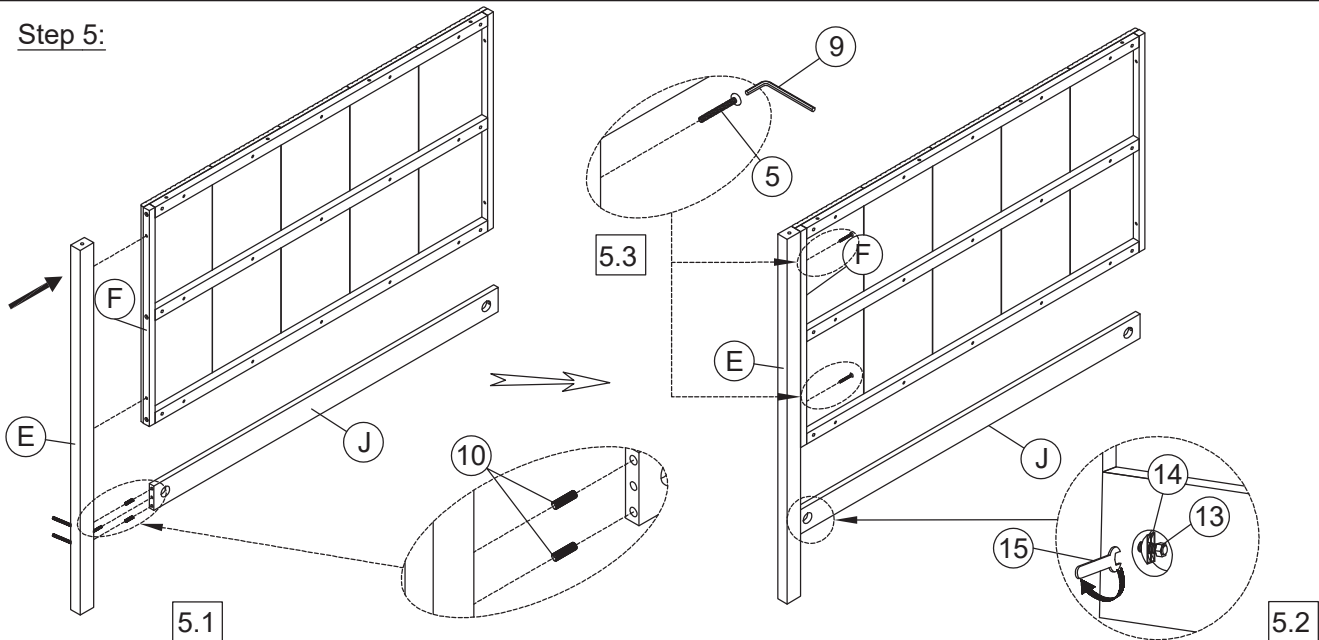

-Assemble the unit in step 3, Headboard crossbar (J) to Leg-right headboard (E).

5.1:Headboard crossbar (J) is assembled with Leg-right headboard (E) using Wooden dowel (10) as shown.

5.2:Following step 5.1, assemble using Half moon washer (14), Hex nut (13), and Open wrench (15) as shown.

5.3 :Assemble the unit from step 3 to Leg-right headboard (E) using Bolt (5) and Allen wrench (9) as shown.

Do not fully tighten the Bolts.

Step 6:

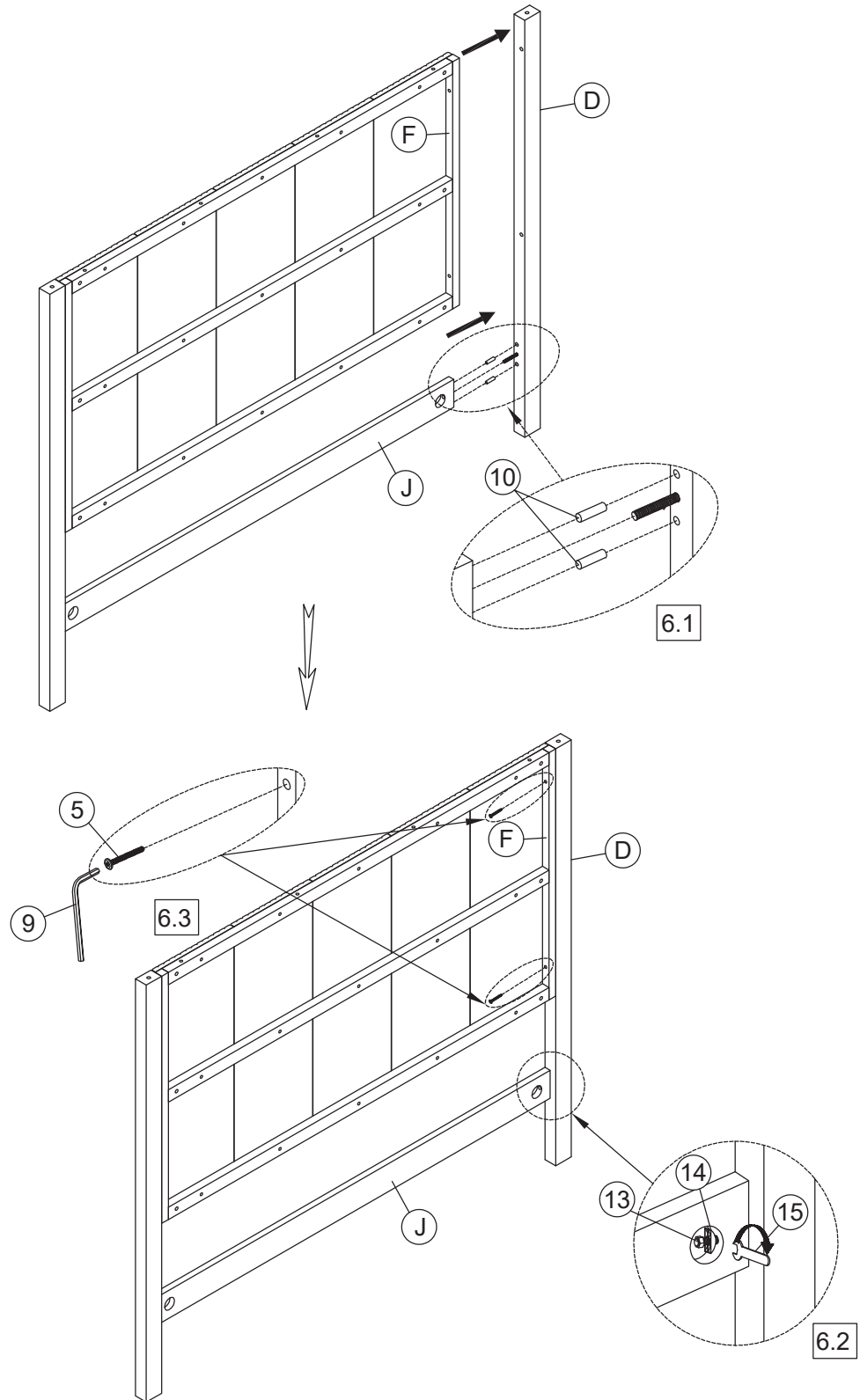

-Assemble the unit in step 5 to the Leg-left headboard (D).

6.1: Attach the Headboard crossbar (J) to the Leg-left headboard (D) using Wooden dowel (10) as shown.

6.2: Following step 6.1, connect using Half moon washer (14), Hex nut (13), and Open wrench (15) as shown.

6.3: Attach the headboard frame to the Leg-left headboard (D) using Bolt (5) and Allen wrench (9) as shown.

Do not fully tighten the Bolts.

Step 7:

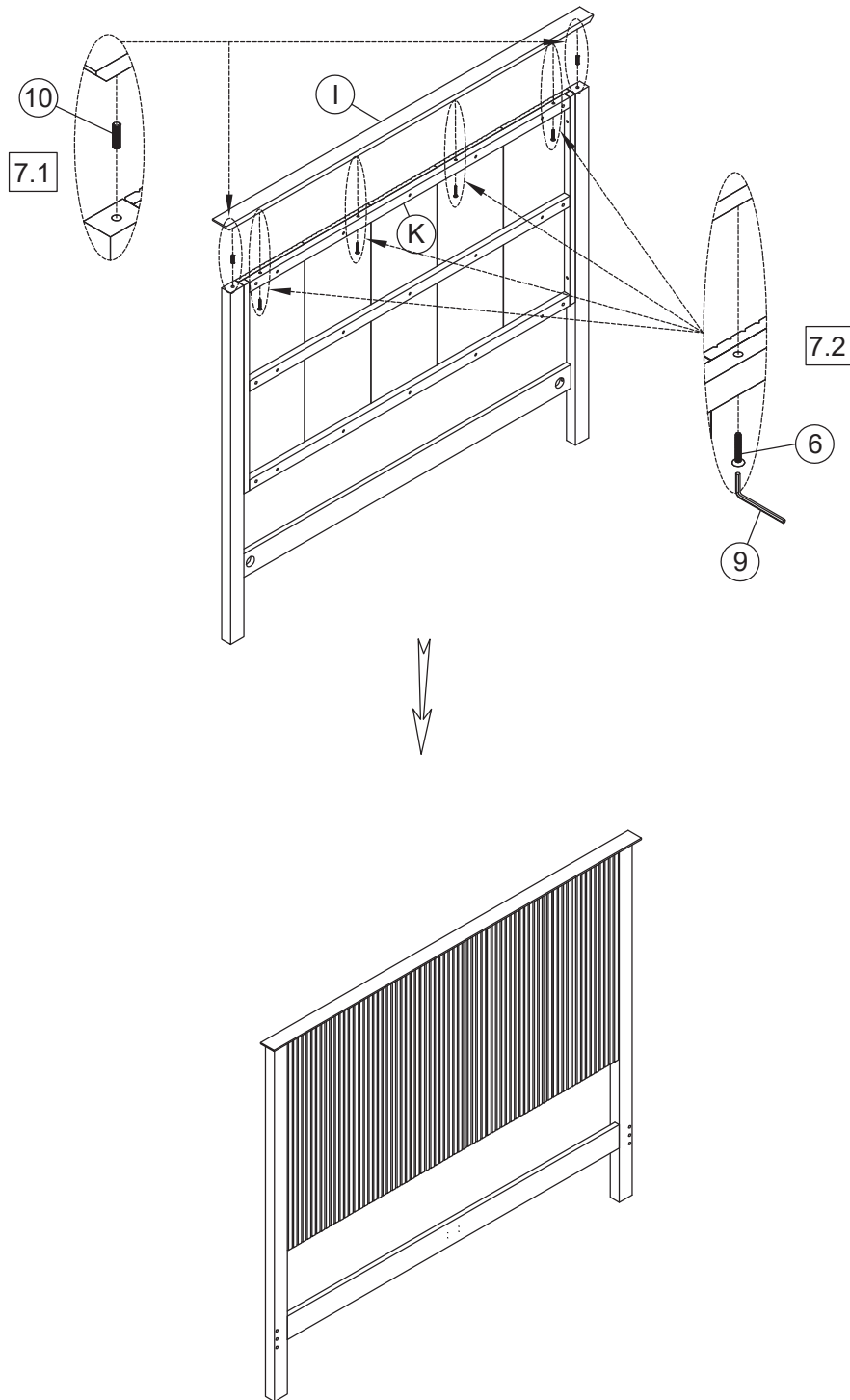

Assemble The bar on the headboard (I) into the assembly completed in step 6.

7.1: Attach The bar on the headboard (I) to the assembly completed in step 6 using Wooden dowel (10) as shown.

7.2: In step 7.1, connect using Bolt (6) and Allen wrench (9) as shown.

Do not fully tighten the Bolts.

Step 8:

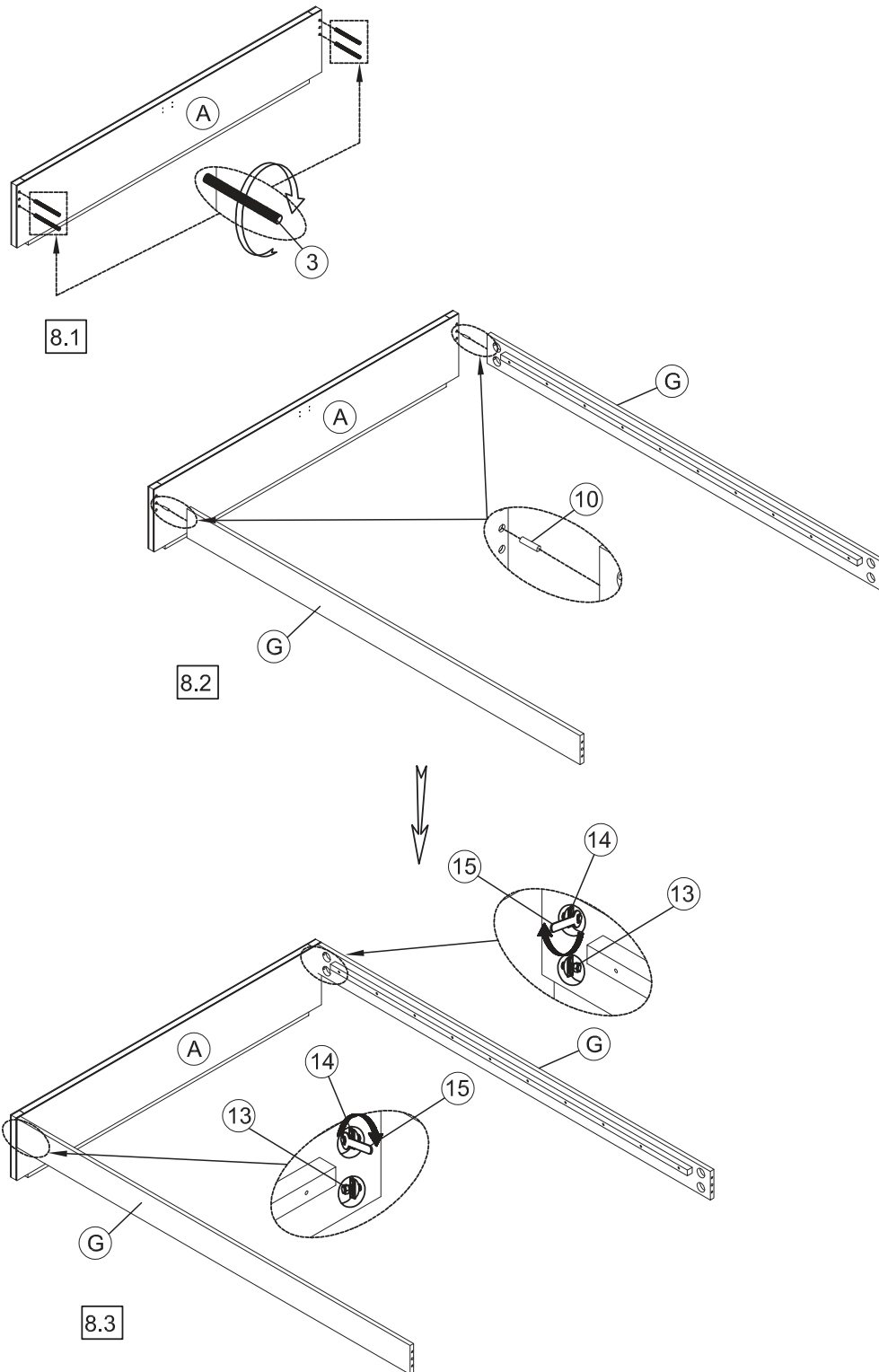

-Assemble side panel (G) to Bed Frame (A).

8.1: Attach the Threaded Rod (3) to Bed Frame (A) as shown in the illustration.

8.2: Attach side panel (G) to Bed Frame (A) using Wooden dowel (10) as shown.

8.3: Following step 8.2, connect the assembly using Half moon washer (14), Hex nut (13), and Open wrench (15) as shown.

Do not fully tighten the Bolts.

Step 9:

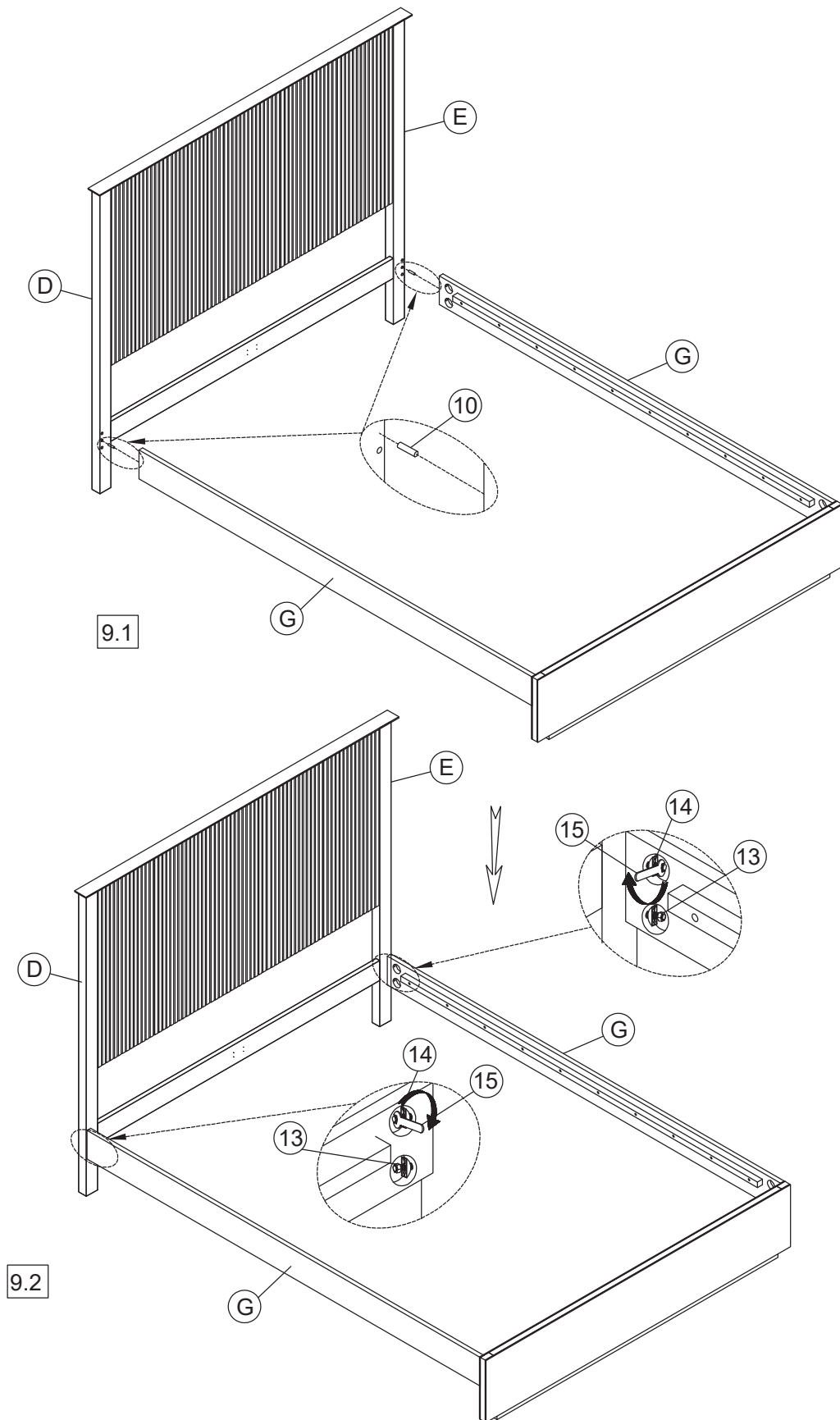

Assemble the unit in step 7 to the unit assembled in step 8.

9.1: Connect the unit in step 7 to the unit assembled in step 8 using Wooden dowel (10) as shown.

9.2: Following step 9.1, secure the unit with Half moon washer (14), Hex nut (13), and Open wrench (15) as shown.

Do not fully tighten the Bolts.

Step 10:

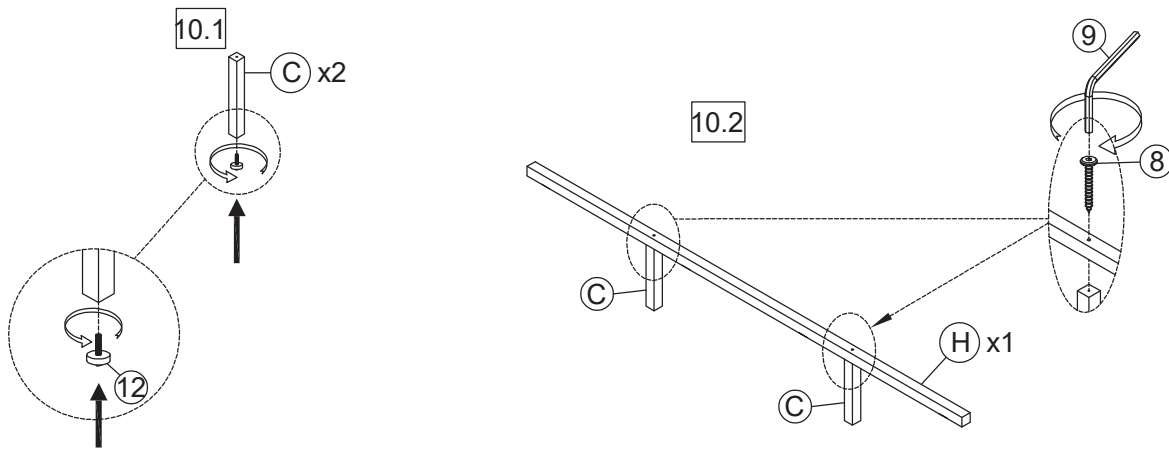

10.1: Attach Leveler (12) to Center support leg (C) as shown in the image.

10.2: After step 10.1, attach the Center support leg (C) to the Center rail (H) using Screws (8) and the Allen wrench (9) as shown in the image.

Do not fully tighten the Bolts.

Step 11:

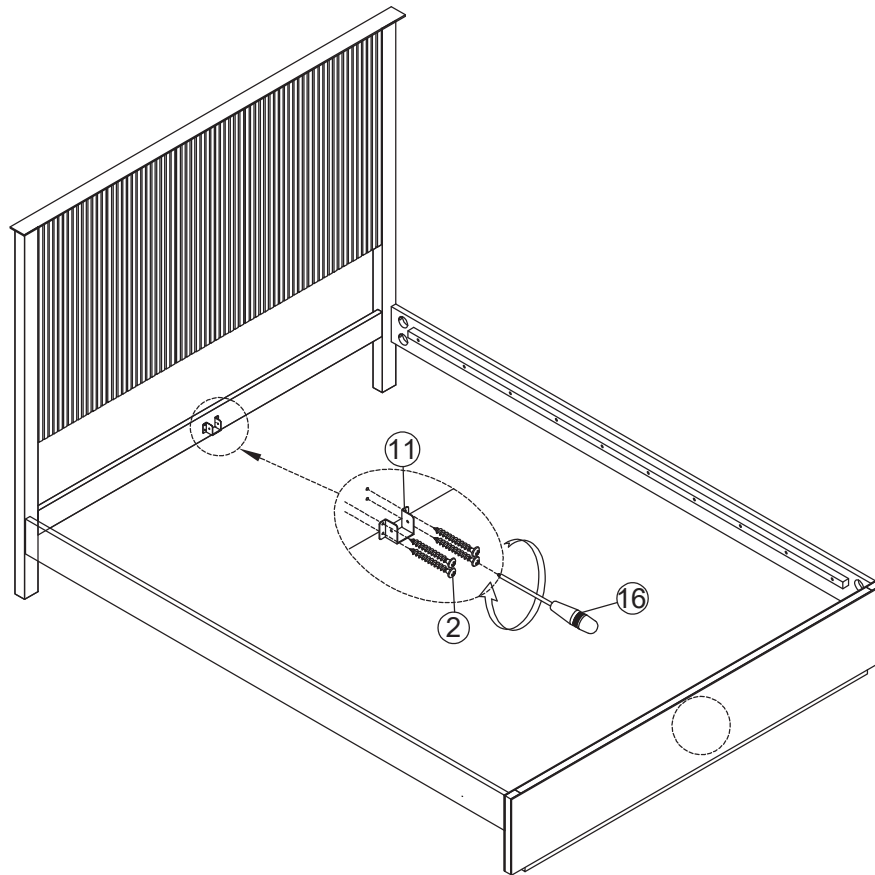

-Attach the Metal link (11) to the headboard using Vis Ø4x15mm (2) and Screwdriver (16) through the drilled hole positions as shown in the image.

Do not fully tighten the Bolts.

Step 12:

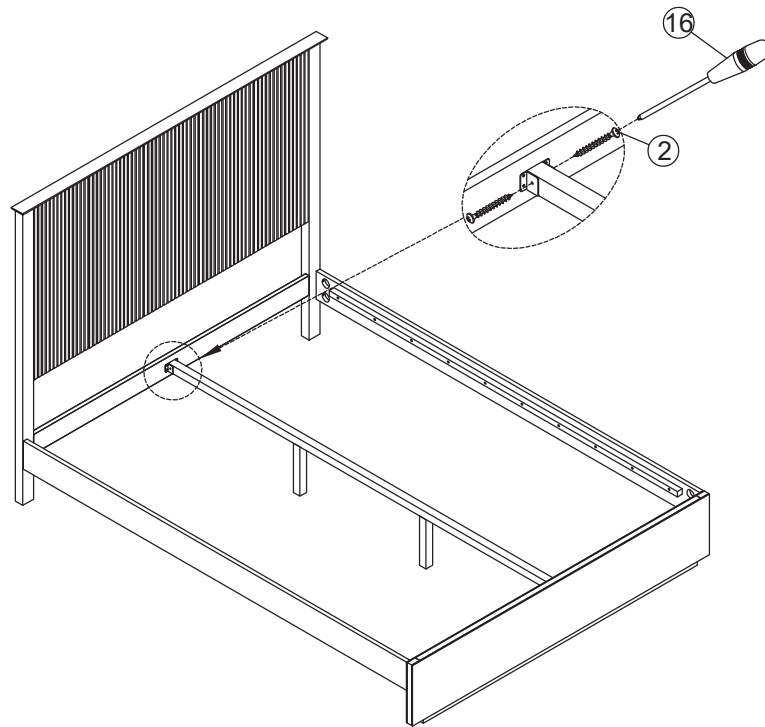

-Attach the assembly completed in step 10 to the Metal link (11) using Vis Ø4x15mm (2) and Screwdriver (16) as shown in the image.
Do not fully tighten the Bolts.

Step 13:

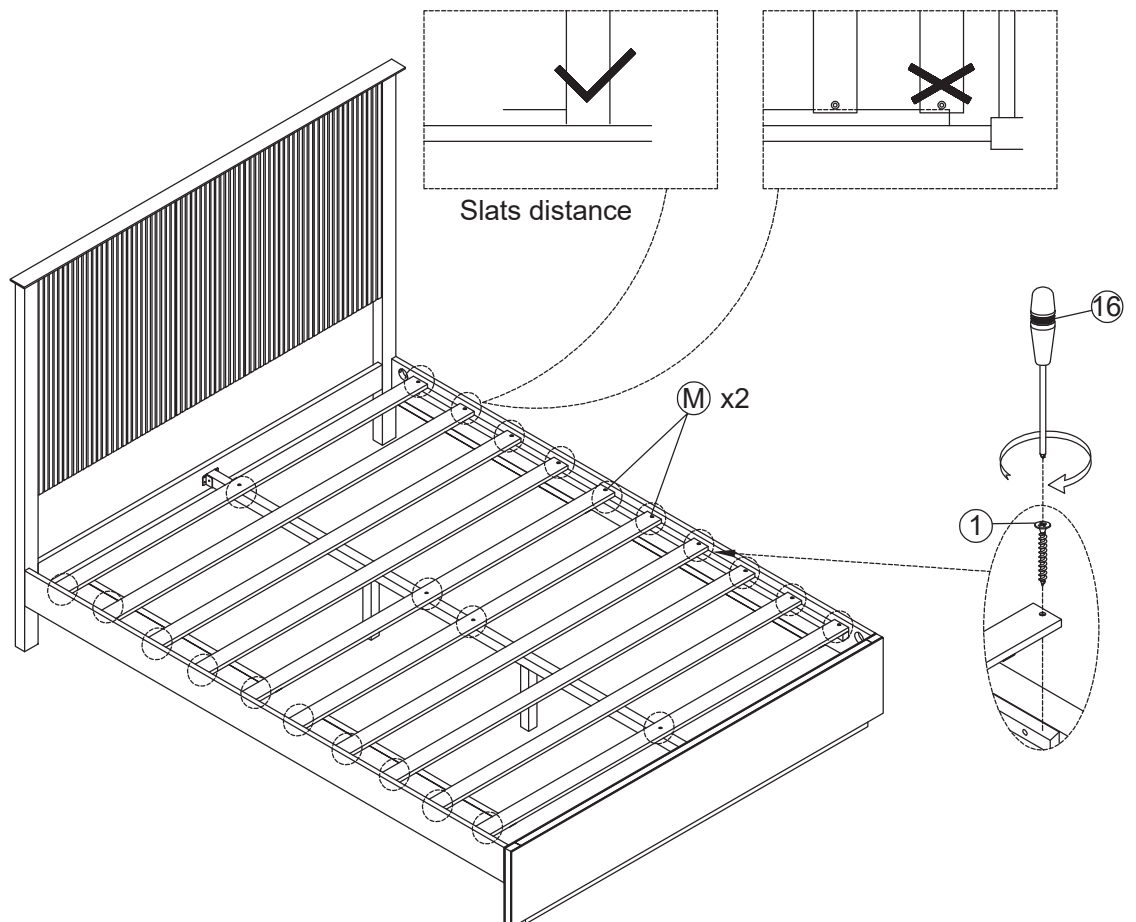

-Attach the Slats (M) to the bed frame as shown using Vis Ø4x30mm (1) and Screwdriver (16) as illustrated.
TIGHTEN ALL HARDWARE 100%

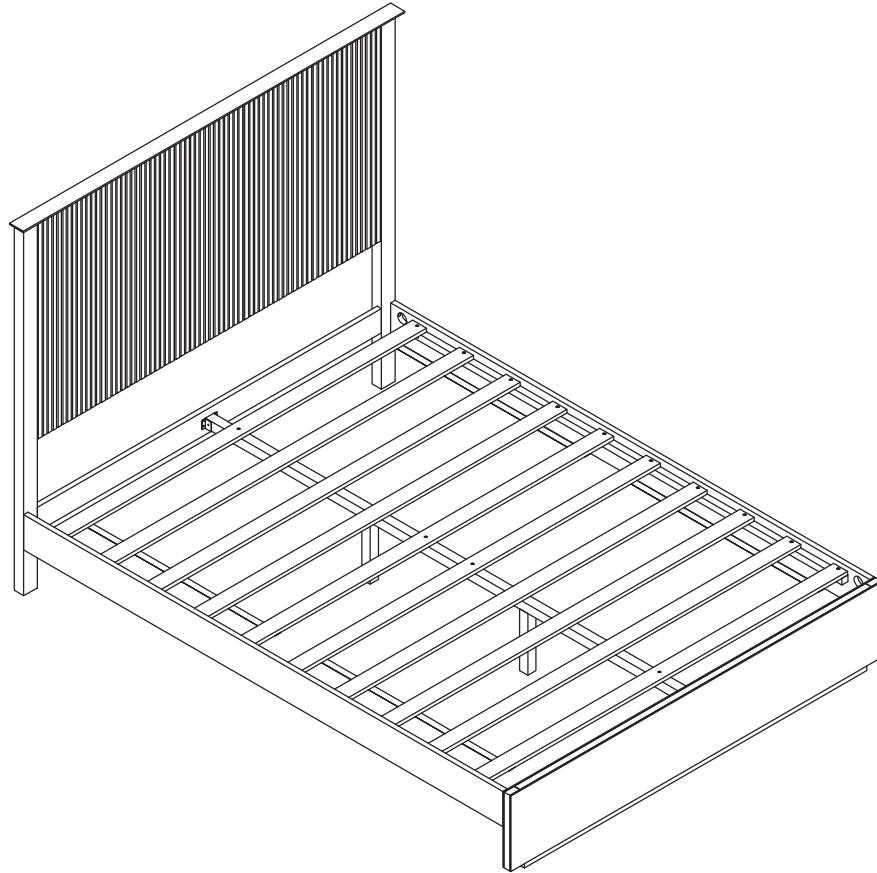

**Inspect the Bed and make sure all parts are adequately connected.
Adjust the Levelers to desired height to avoid wobbles.
Your bed is ready for use.**

CARE INSTRUCTIONS:

**Hardware may loosen overtime. Periodically check that all connections are tight.
Wipe with a soft, dry cloth. To protect finish, avoid the use of chemicals and household
cleaners.**