

**PROBRITE™**

**SOL LED  
ARCHITECTURAL  
CEILING/WALL**

**INSTALLATION,  
USAGE, & CARE GUIDE**

Model No.	SOL12-3K-WH SOL20-3K-WH
Mfr. SKU	103-07600002-1 103-07700002-1



**Questions? / Missing Parts? / Need Accessories?**

Before returning to the store, call or email PROBRITE  
Customer Service 9am-5pm EST Monday to Friday.

**1-844-507-5651**

**support@PROBRITE.com**

**PROBRITE.COM**

---

*Visit us online anytime or call us to get information on our product range, download detailed spec & photometric files, find product and mounting accessories, view installation tutorials and videos, and learn about our DLC® rebate eligible products.*

## Table of Contents

<b>Table of Contents</b> .....	<b>2</b>	Package Contents.....	4
<b>Safety Information</b> .....	<b>2</b>	<b>Installation</b> .....	<b>5</b>
<b>Pre-Installation</b> .....	<b>3</b>	<b>Care &amp; Cleaning</b> .....	<b>9</b>
Planning Installation.....	3	<b>Troubleshooting</b> .....	<b>9</b>
Specifications.....	3	<b>Warranty</b> .....	<b>10</b>
Tools Required.....	3		
Hardware Included.....	4		

## Safety Information

### IMPORTANT

THIS PRODUCT MUST BE INSTALLED IN ACCORDANCE WITH THE APPLICABLE NATIONAL ELECTRICAL CODE AND LOCAL BUILDING CODES BY A PERSON FAMILIAR WITH THE CONSTRUCTION AND OPERATION OF THE PRODUCT AND THE HAZARDS INVOLVED.

### PRECAUTIONS

- Please read and understand this entire manual before attempting to assemble, install, or operate this light fixture.
- This light fixture requires a 120-Volt AC power source.
- Some codes require installation by a qualified electrician.
- This light fixture must be properly grounded.
- Make sure connections are secure using wire nuts, crimp-on lugs or other approved connecting devices
- This light fixture should be installed outdoors to a wall or eave.
- This product may contain chemicals known to be hazardous. Thoroughly wash hands after installing, handling, cleaning or otherwise touching the product.



**WARNING:** Turn the power off at the circuit breaker or fuse. Place tape over the circuit breaker switch and verify power is off at the light fixture.



**WARNING:** Risk of fire. Keep the lamp heads at least 3 in. (76mm) from combustible materials.



**CAUTION:** Burn hazard. Allow the light fixture to cool before touching.



**NOTICE:** Do not connect this fixture to a dimmer switch.



**NOTICE:** FCC Regulations state that any unauthorized changes or modifications to this equipment not expressly approved by the manufacturer could void the user's authorization to operate this equipment.



**INFORMATION:** The device is tested and found to comply with Part 15 of the FCC Rules. Operation is subject to two conditions: (1) This device may not cause harmful interference and, (2) this device must accept any interference received, including any interference that may cause undesired operation.

These limits are designed to provide reasonable protections against harmful interference when the equipment is operated in a commercial environment.

## Pre-Installation

### PLANNING INSTALLATION

Before installing the light fixture, ensure that all parts are present. Compare parts with the *Hardware Included* and *Package Contents* sections. If any part is missing or damaged, do not attempt to assemble, install, or operate this light fixture.

Estimated installation time: 20 minutes

### SPECIFICATIONS

MODEL	SOL 12W	SOL 20W
<b>Lumens (Light Output)</b>	900 Lumens	1600 Lumens
<b>Watts (Power Consumption)</b>	12 Watts LED	20 Watts LED
<b>Replaces</b>	75 Watt Bulbs	150 Watt Bulbs
<b>Lumens/Watts (Efficacy)</b>	75 lumens per watt	80 lumens per watt
<b>Power Requirements (Input Voltage)</b>	120VAC, 60 Hz	
<b>Light Color (CCT)</b>	3000 Kelvins (Warm White)	
<b>Dimmable</b>	Non-Dimming (Do not wire to dimming switch)	
<b>Operating Modes</b>	<b>Switch-Activated:</b> Flip switch to turn light fixture ON and OFF. Use external photocell light sensor, timer or motion sensor for automatic functionality (sold separately)	

### TOOLS REQUIRED



⊕ Phillips Screwdriver



Wire strippers/cutters



Circuit tester



Silicone Sealant



Work gloves



Ladder



Safety goggles

## Pre-Installation (continued)

### HARDWARE KIT



**NOTE:** Hardware *not* shown to actual size.

AA

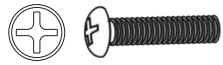

BB

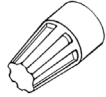

CC

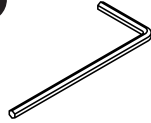

Part	Description	Quantity
AA	#8-32 x 3/4" philips mounting bracket screw	2
BB	Wire nut	3
CC	Allen key	1

### PACKAGE CONTENTS

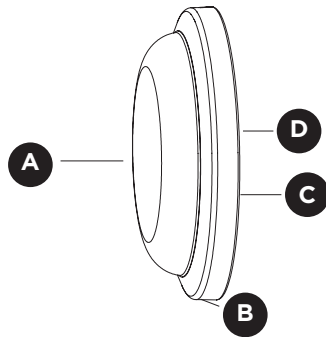

Part	Description	Quantity
A	Light fixture	1
B	Mounting plate tightening bolt (pre-installed)	1
C	Mounting plate (pre-installed)	1
D	Hanger Wire for hands-free installation (pre-installed)	1

## Installation

### 1 For best results

- The fixture can be mounted on the wall as well as on the ceiling.
- For wall mount install light 1-12 feet above the ground.
- For ceiling mount install light 8-15 feet above the ground.
- When installing two fixtures on one switch, make sure the switch is rated for at least a 1A inductive load.
- Do NOT wire to a dimming switch.

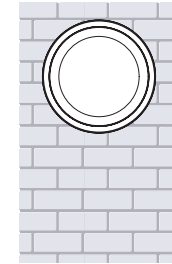

Wall Mount



Ceiling Mount



**NOTE:** Mounting plate (D) mounts to recessed mounted standard junction boxes. Junction box must be at least 1-1/2 inch in depth for proper installation for recessed mount application (fig 1).

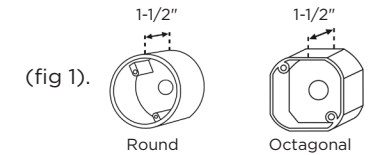

### 2 Shut electric power off

- At wall switch verify it is in the off position (fig 1).
- At the main electrical panel turn off the circuit breaker that supplies power to the outlet box you are working on (fig 2).
- For screw-in type fuses unscrew the fuse that supplies power to the outlet box you are working on (fig 3).



(fig 1).

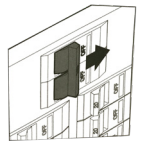

(fig 2).

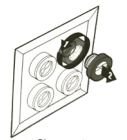

(fig 3).

## Installation (continued)

### 3 Remove the mounting plate

**NOTE:** The mounting plate (C) comes pre-assembled on the light fixture (A) for shipping.

**NOTE:** The mounting plate tightening bolt (B) comes pre-installed on the light fixture.

- Remove the mounting plate (C) from the back of the fixture by loosening the mounting plate tightening bolt (B) using the allen key (CC).

**TIP:** Only unscrew the tightening bolt (B) far enough to remove the mounting plate (C). Do not fully remove the tightening bolt (B).

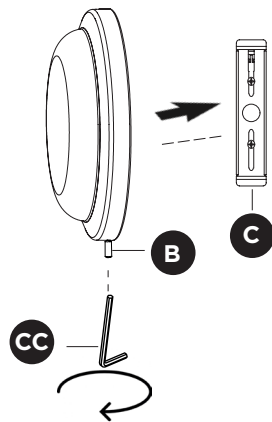

### 4 Installing the mounting plate

- Route the junction box wires through the large center hole in the mounting plate (C).
- Align the holes on the mounting bracket (C) with the holes on your junction box. Use two #8 screws (AA), depending on the size of the holes in your junction box, attach the mounting bracket (C) to your junction box.

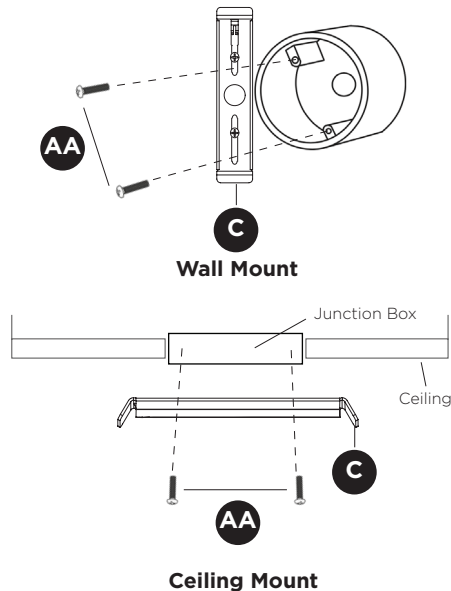

## Installation (continued)

### 5 Hang fixture to mounting plate

**TIP:** Ensure the light fixture (A) can safely hang onto the mounting plate (D) to allow for use of two hands to make the wiring connections.

- Place the small sphere head of the hanger wire (D) between the back of the small groove located on the bottom of the center hole of the mounting plate (C).

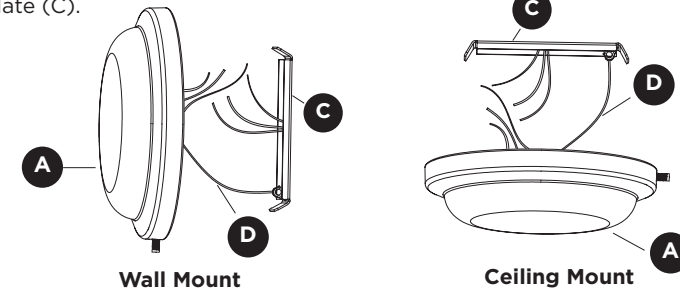

### 6 Making the electrical connections

- If necessary, strip 3/8" of insulation from junction box or fixture (A) wires (fig 1).
- Connect *fixture black wire* to *house black wire*, the (+) line, and *fixture white wire* to *house white wire*, the (-) common by twisting the exposed wires together and using the wire nuts (BB). Ensure no loose wires.
- Connect *house ground wire* to the *green fixture ground wire*, which is attached to the mounting plate (C), by twisting the exposed wires together and using the wire nuts (BB).

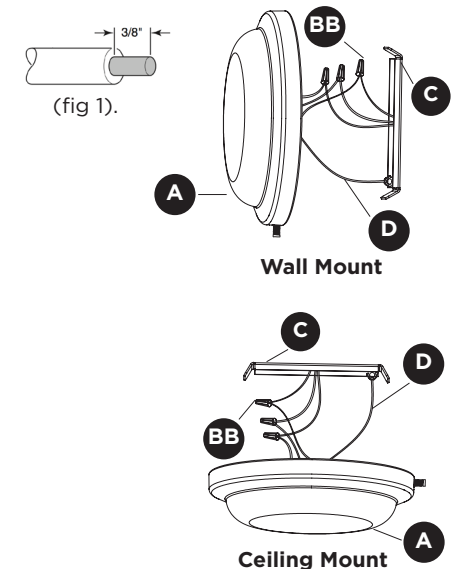

**TIP:** Hold stripped ends near each other and align any frayed strands (do not twist wires).

Push the wires into wire nut (BB) and use your fingers to twist the wire nut clockwise until tight. Check for tightness by pulling wires.

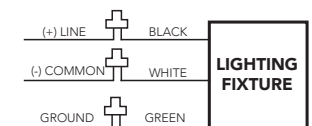

## Installation (continued)

### 7 Mounting the light fixture

- Once the fixture is wired, place the light fixture (A) onto the mounting plate (C) so the top sloped groove on the plate rests on the top sloped groove on the back of the fixture.
- Tighten the mounting plate by tightening bolt (B) through the hole on the bottom of the fixture (A) until the bolt firmly pushes against the mounting plate (C).

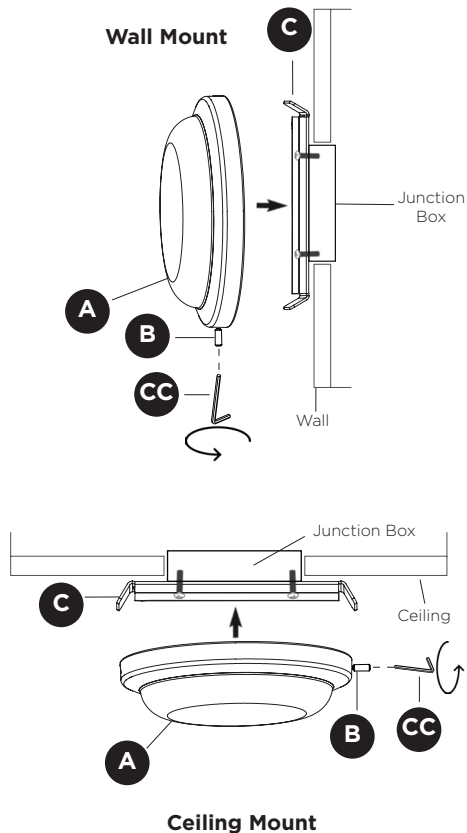

### 8 Caulking around the light fixture

- Caulk around the mounting plate (C) and surface with silicone sealant (not included).

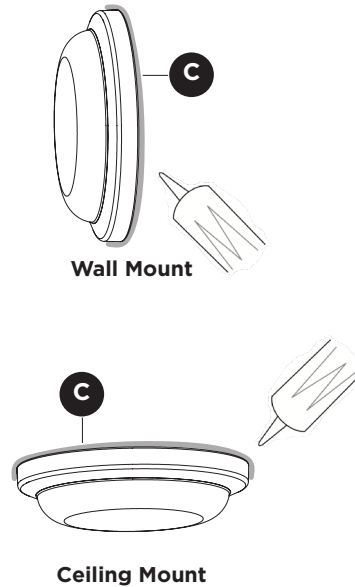

**NOTICE:** Failure to properly caulk around the surface and mounting plate (C) could lead to water damage and is not covered under warranty.

**NOTE:** When attaching this fixture (A) to an external, surface mount junction box, caulk the inside of the light fixture before attaching to the mounting plate (C).

## Operation

### SWITCH-CONTROLLED

Switch-controlled operation enables the light fixture to turn ON and OFF by flipping a standard light switch. To add automatic Dusk to Dawn control or motion sensing external sensors like a photo-control, motion-sensor or timer is required (*sold separately*).



- Once the fixture is installed, turn power back on from the circuit breaker and switch.
- Flip switch ON and OFF to ensure light functions properly.



**NOTE:** This fixture is not dimmable, so it is best to not wire to a dimming switch.

## Care and Cleaning

- Shut off main power supply before cleaning the product. To prolong the original appearance, clean the light fixture with clear water and a soft, damp cloth only.
- Do not use abrasive cleaners or cleaners that contain alcohol. Do not apply paints, solvents, or any other chemicals on this light fixture. They could cause a premature deterioration of the finish and may void the warranty.
- Do not spray the light fixture with a hose or power washer.

## Troubleshooting

If Light does not turn on:

- Verify that the power is turned ON from the circuit breaker and wall switch.
- Verify the wiring for the fixture is done properly.
- Verify the line voltage is correct.

If Light flickers:

- Do not wire to a dimming switch, use a standard ON/OFF switch

## 5-Year Limited Warranty

---

This is a limited warranty offered by Probrite for a period of five years from the date of purchase to its customers. Probrite warrants to customers that the products will be free from defects in material and workmanship. The obligation of Probrite under this warranty is limited to the provision of replacement of products and is extended to the original purchaser of the product on presenting valid purchase receipt or other proof of date of original purchase acceptable to Probrite. The receipt is required for rendering the warranty performance. Any warranty claims without original proof of purchase would not be accepted.

It should be noted that the warranty does not apply to Probrite products that have been altered or repaired by unauthorized personnel, have been subjected to neglect, abuse, misuse or accident or damages caused during shipping. Any other products not manufactured by Probrite which have been supplied, installed and/or used in conjunction with Probrite products are not covered under this warranty. Any damages caused by replacements bulbs, LEDs or corrosion or discoloration of brass components are also not covered by this warranty.

### **Limitation of Liability:**

In no event Probrite shall be liable for indirect, consequential, incidental or special damages, or lost profits. Probrite is not liable for any claims or damage arising out of or connected with the manufacture, sale, delivery, use, maintenance and repair or modification of Probrite products, or supply of any replacement parts that, exceed the purchase price of Probrite products giving rise to a claim. Labor charges to remove or install the fixtures will not be accepted.

### **To Claim:**

Please contact PROBRITE customer service at 1-844-507-5651 or email [support@PROBRITE.com](mailto:support@PROBRITE.com) and include your name, address and contact number, along with a copy of the purchase receipt and a brief description of the problem.

# **PROBRITE™**

## **Questions? / Missing Parts? / Need Accessories?**

Before returning to the store, call or email PROBRITE  
Customer Service 9am-5pm EST Monday to Friday.

**1-844-507-5651**

**support@PROBRITE.com**

**PROBRITE.COM**

**RETAIN THIS MANUAL FOR FUTURE USE**

**Para las translaciones en español,  
visit [www.probrite.com/install](http://www.probrite.com/install)**