

ASSEMBLY INSTRUCTION

Writing Desk

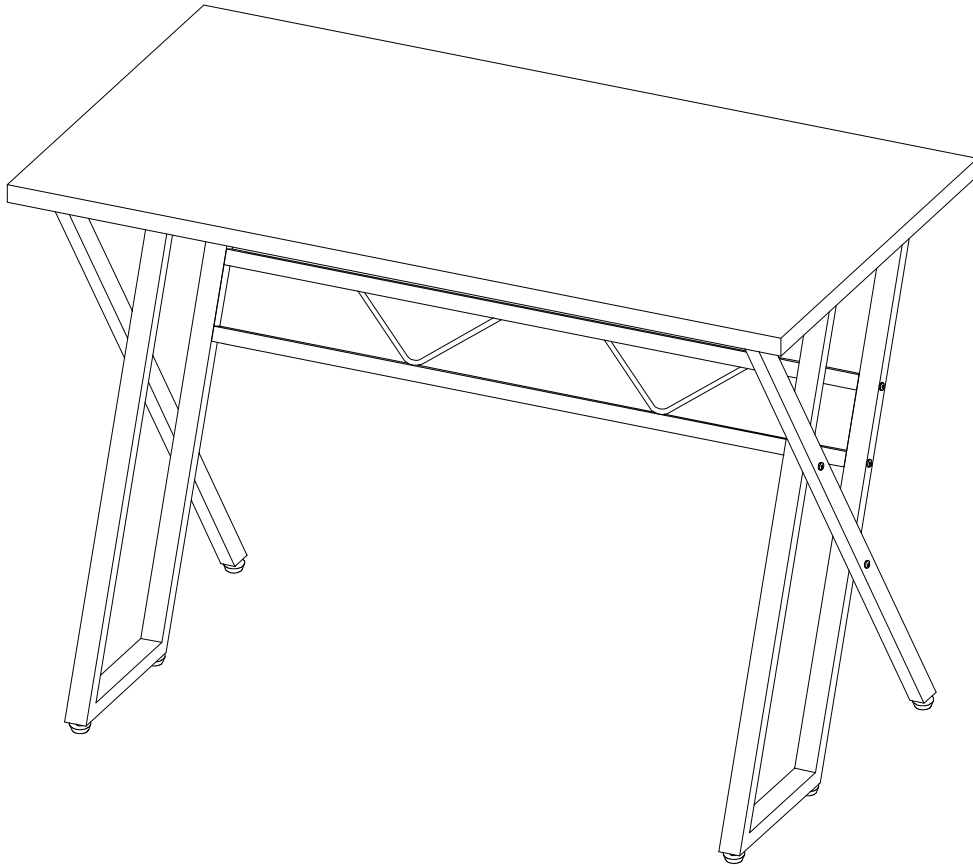



NOTE TO CUSTOMERS:

- For ease and speed of assembly we recommend that before you commence each step of the assembly that you identify all the parts required to complete that step.
- We recommend that where possible you allow sufficient space to assemble the item as close as possible to the place where it will be once assembled.
- For the protection of your furniture we recommend that the product is placed on protected surfaces during assembly to prevent any damage.
- During assembly do not over tighten ,as this may damage the product.
- Please ensure you retain all the product packaging until the item completely assembled.
- Please periodically check all fittings and re-tighten as necessary.
- Never allow any liquids to remain on your furniture as absorption can cause the wood to warp or the finish to de-laminate.
- It is recommended that this item should be assembled by two adults.

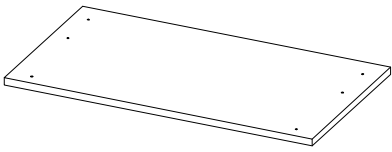
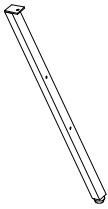
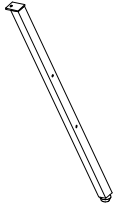
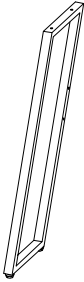
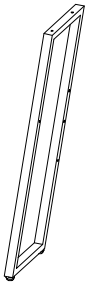
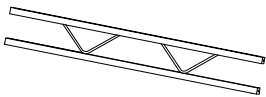
Part List

<p>A1</p>  <p>Quantity of 1</p> <p>Table Top</p>	<p>A2</p>  <p>Quantity of 1</p> <p>Left Support Leg</p>	<p>A3</p>  <p>Quantity of 1</p> <p>Right Support Leg</p>	
<p>A4</p>  <p>Quantity of 1</p> <p>Left Leg</p>	<p>A5</p>  <p>Quantity of 1</p> <p>Right Leg</p>	<p>A6</p>  <p>Quantity of 1</p> <p>Frame</p>	

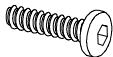
Hardware List

<p>B1</p>  <p>Quantity of 2</p> <p>M1/4"*5/8"L</p> <p>Bolt</p>	<p>B2</p>  <p>Quantity of 8</p> <p>M1/4"*1-1/4"L</p> <p>Bolt</p>	<p>B3</p>  <p>Quantity of 4</p> <p>M1/4"*2"L</p> <p>Bolt</p>	<p>B4</p>  <p>Quantity of 1</p> <p>Allen Key</p>
--	--	---	--

Step 1:

B1  2PCS

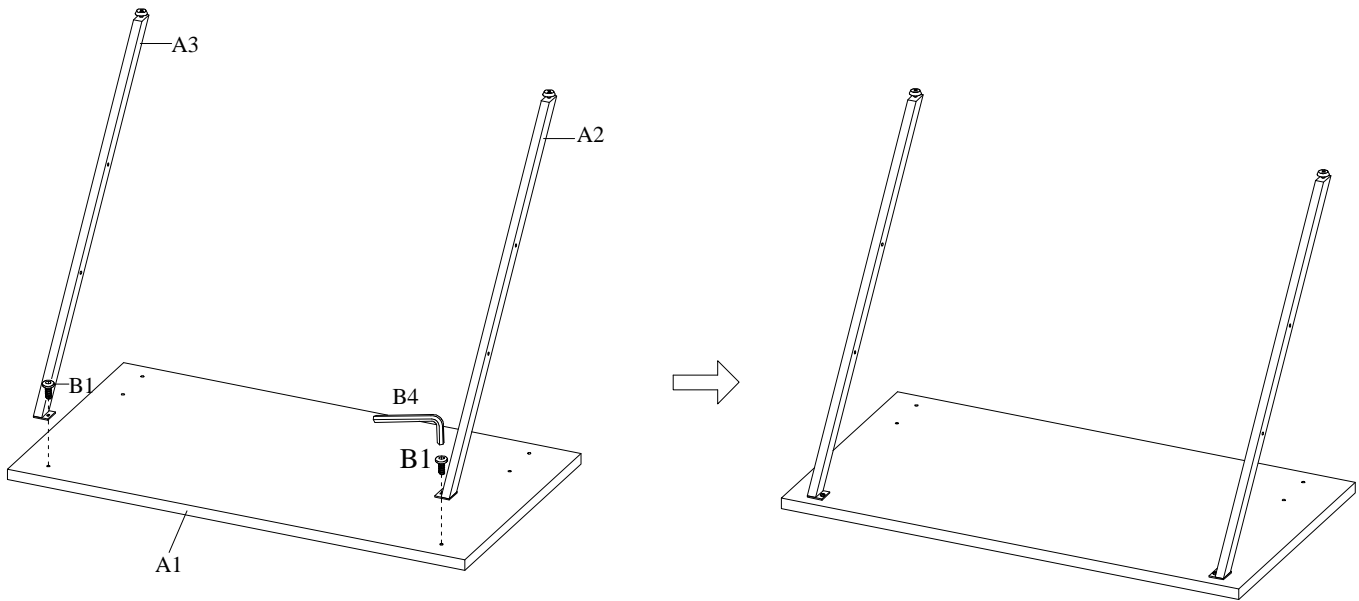

Assemble Support Legs A2 & A3 to the bottom of Table Top A1 using Bolts B1.
Please do not tighten Bolts B1 until step 4.

Step 2:

B2  8PCS

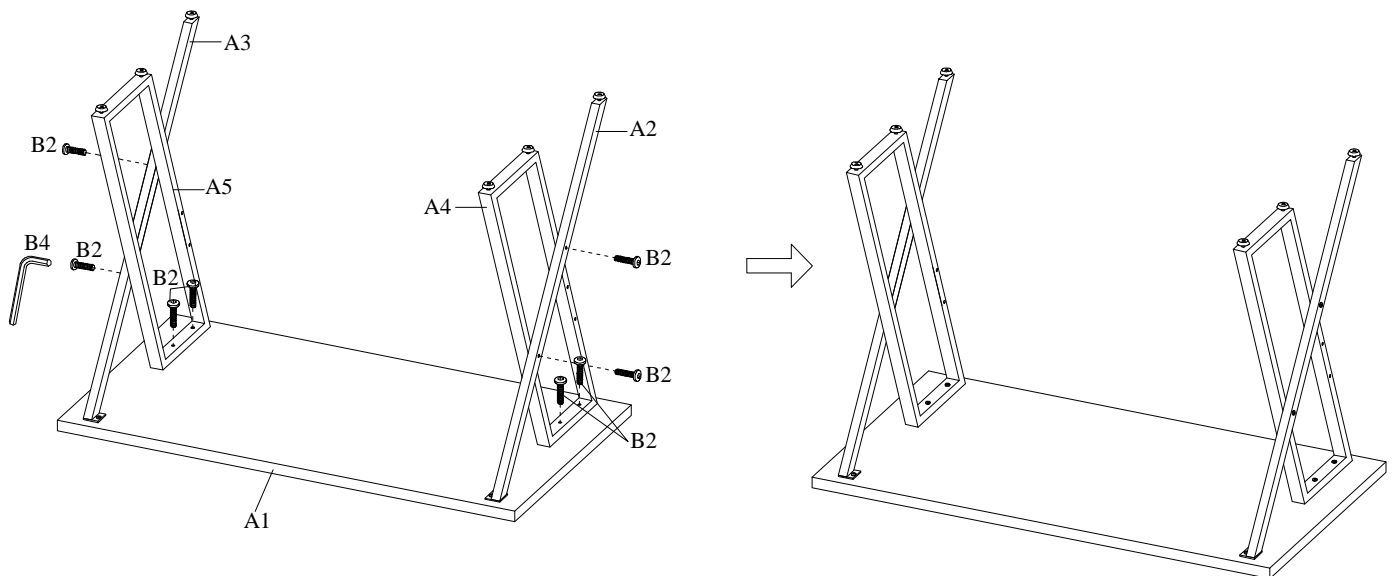

1). Assemble Legs A4 & A5 to the bottom of Table Top A1 using Bolts B2.
2). Assemble Support Legs A2 & A3 to Legs A4 & A5 using Bolts B2.
Please do not tighten Bolts B2 until step 4.

Step 3:

B3  4PCS

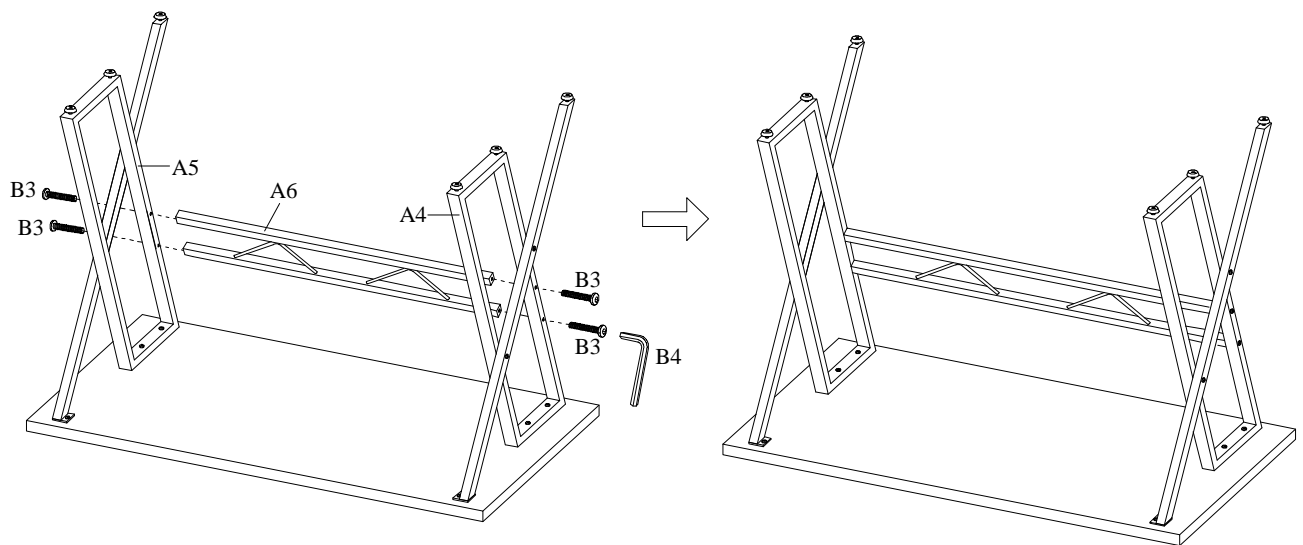

Assemble Frame A6 to Legs A4 & A5 using Bolts B3.
Please do not tighten Bolts B3 until step 4.

Step 4:

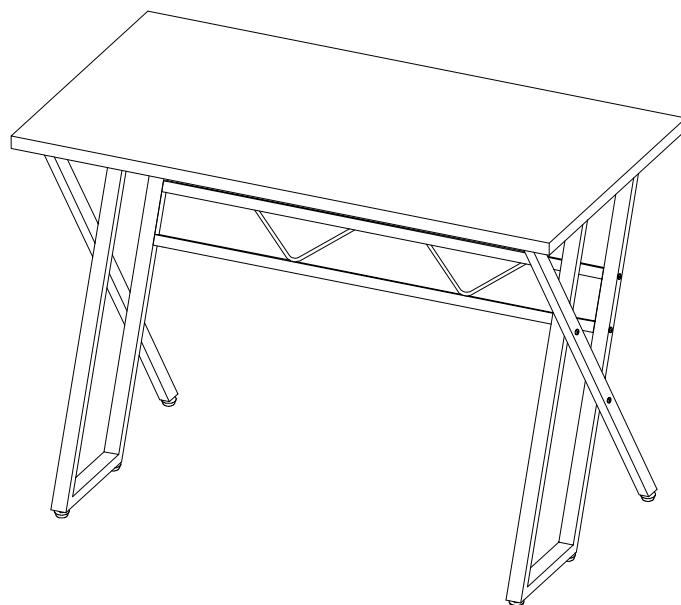

Place the desk on the floor to check if it is stable before tightening all Bolts.
Note: Please adjust the levelers if it is not stable.