

# ASSEMBLY INSTRUCTIONS

## STEP 1

Lay the TABLE TOP (A) upside-down on a smooth flat surface. Insert LEGS (C) into the round slots on the bottom of the TABLE TOP (A). Make sure LEGS (C) are fully inserted into the TABLE TOP (A).

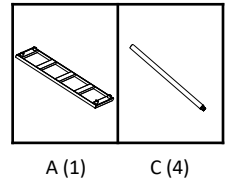

**You will insert and tighten the HEX SCREWS (D) in Step 3.**

**Do NOT tighten HEX SCREWS (D) in Step 1.**

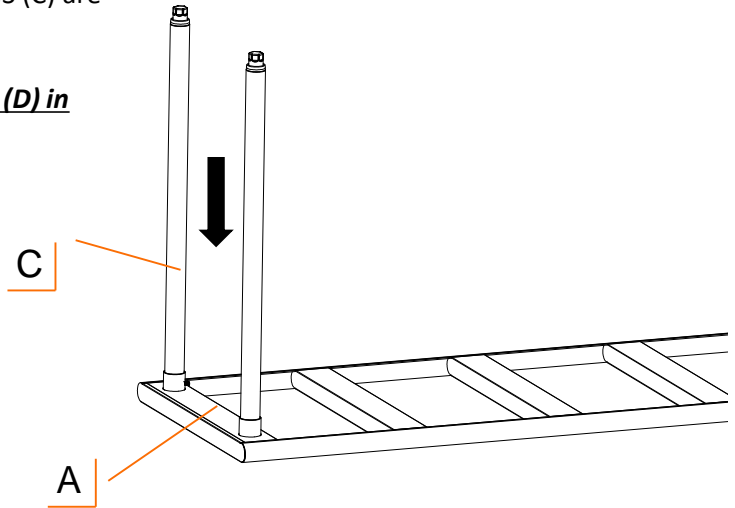

## STEP 2

With another person's help, slide the SHELF (B) over each LEG (C) to the desired height. Using HEX KEY (F), tighten the HEX SCREW (D) clockwise into SHELF (B), until HEX SCREW (D) is securely in place.

Repeat step to ensure each HEX SCREW (D) is properly installed.

Place a SCREW CAP (E) over each HEX SCREW (D).

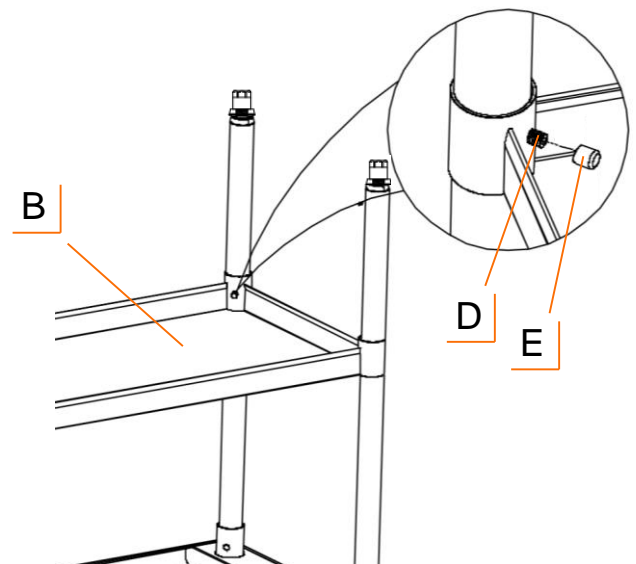
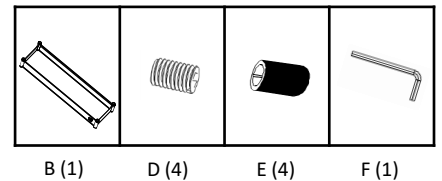

# ASSEMBLY INSTRUCTIONS

## STEP 3

Using HEX KEY (F), tighten HEX SCREW (D) clockwise into TABLE TOP (A), until HEX SCREW (D) is securely in place.

Repeat step to ensure each HEX SCREW (D) is properly installed.

Place a SCREW CAP (E) over each HEX SCREW (D).

Turn the Table right-side up and adjust Feet Levelers until the Table is stable and level.

