

Installation Guide

Tempest, Tidal I, Tidal II Recirculating Kit

ZRC-7000C

ZRC-7036C

ZRC-7042C

ZRC-7048C

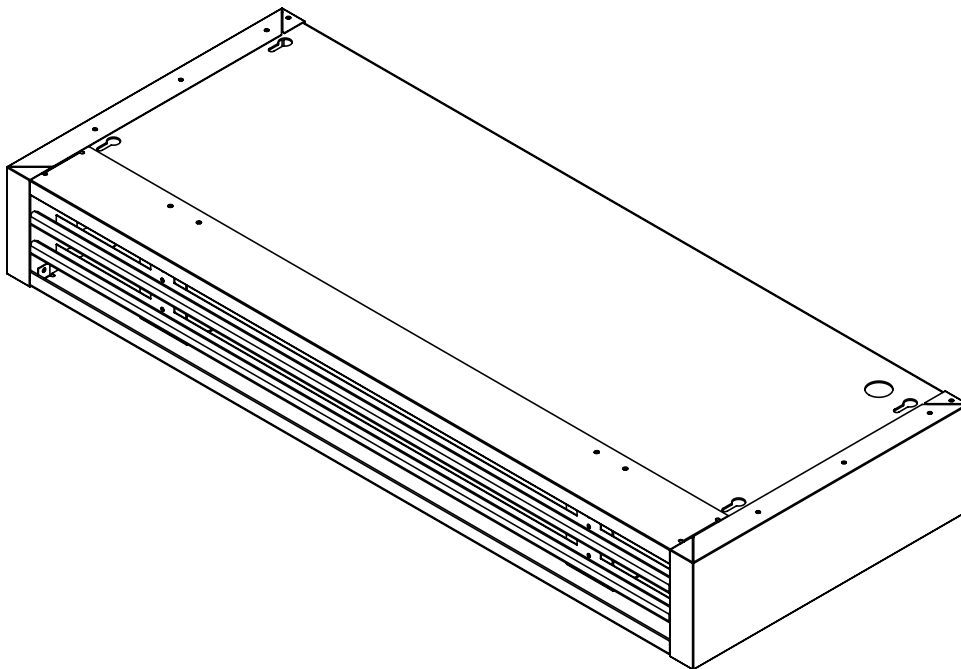

List of Materials

MODELS: ZRC-7000C, ZRC-7036C, ZRC-7042C, ZRC-7048C

PARTS SUPPLIED

- 1 - Air diverter box
- 2 - Carbon filter cartridges (3 - ZRC-7048C)
- 2 - Carbon filter adapters (3 - ZRC-7048C)
- 1 - Hardware package

HARDWARE PACKAGE CONTENTS

#6 x 1" (4)
(6) for 42" & 48"

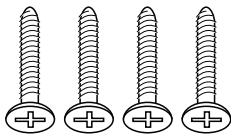

3/16 x 3/8" (4)

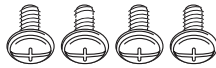

M4 x 8 (4)



PARTS NOT SUPPLIED

- Ducting, conduit and all installation tools
- Cable connector (*if required by local codes*)

REPLACEMENT PARTS

DESCRIPTION

PART #

Replacement Parts

Charcoal Filter (each)

Z0F-C002

To order parts, visit us online at <http://store.zephyronline.com> or call us at 1.888.880.8368

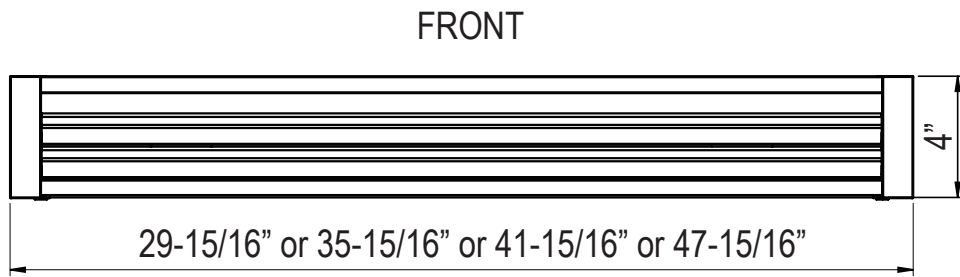
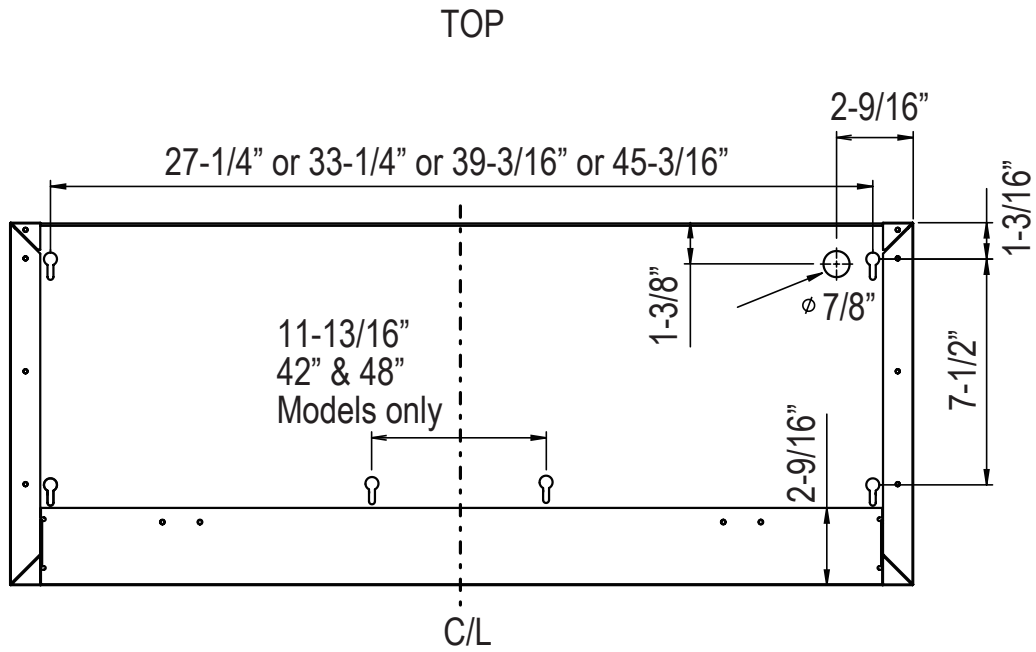

Installation – Mounting the Diverter Box

Mounting the air diverter box

FOR USE WITH AK7000CS, AK7300AS, AK7400AS, AK7500CS, AK7036CS, AK7336AS, AK7436AS, AK7536CS, AK7042CS, AK7542CS, AK7048CS, AK7448AS, and AK7548CS ONLY

FOR USE WITH SINGLE INTERNAL BLOWER ONLY

NOT COMPATIBLE WITH DUAL INTERNAL BLOWER

1. Position the air diverter box under cabinet. Mark the (4 for 30 & 36" models, 6 for 42" & 48" models) key-holes for the #6 x 1" screws and electrical knock out opening with a pencil. Remove air diverter box and install the (4 or 6) #6 x 1" screws. Do not tighten screws all the way. Drill out the electrical knock-out opening.
Note: Reinforce cabinet with 1" x 2" wood strips if additional strengthening is required or if cabinets are framed.
2. Lift air diverter box and align the holes on top of the air diverter box with the screws recently installed. Slide the air diverter box towards the wall to temporarily lock in place. Hand tighten the (4 or 6) screws. (Fig. A)
3. Lift range hood and align the key-holes on top of the hood with the screws protruding from the bottom of the air diverter box. Slide hood towards wall to temporarily lock in place. Hand tighten the (4) screws. (Fig. A)
Note: Electrical wiring will pass through the cabinet bottom, air diverter box and connect to the hood wiring. See Tempest I instruction manual for more details.
4. Further secure the hood to the air diverter box by fastening M4 x 8 screws and 3/16 x 3/8" screws to each of the (8) holes on the bottom of the air diverter box. You can gain access to the screw holes from within the hood. The holes on top of the Tempest I will align with the holes on the bottom of the air diverter box. (Fig. B)

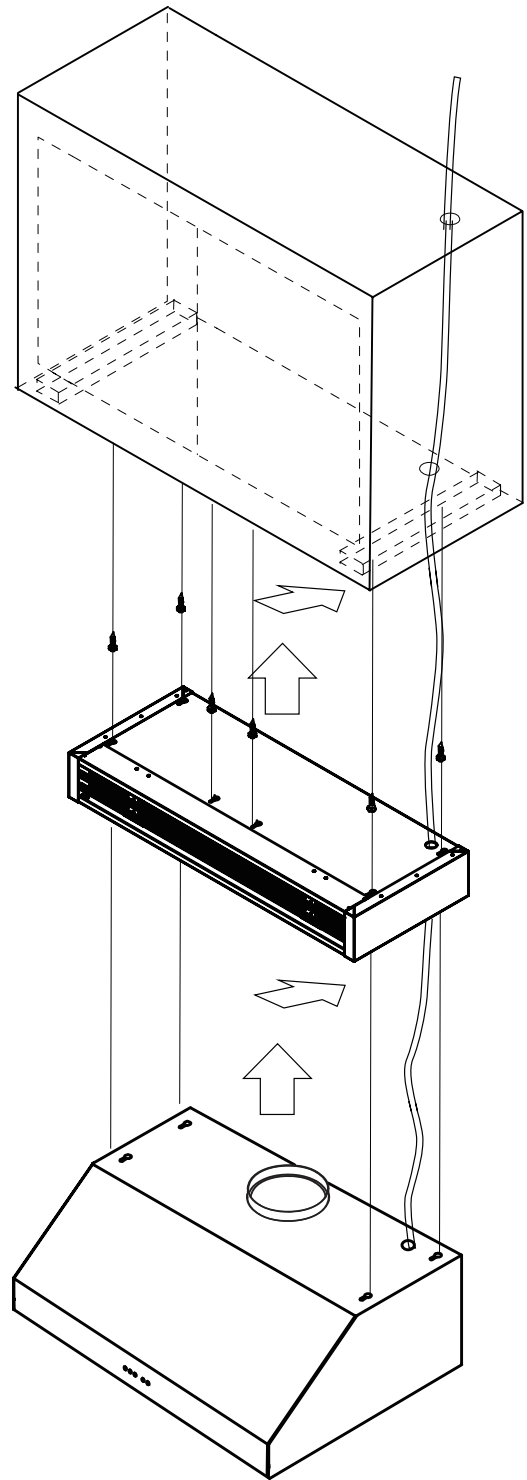
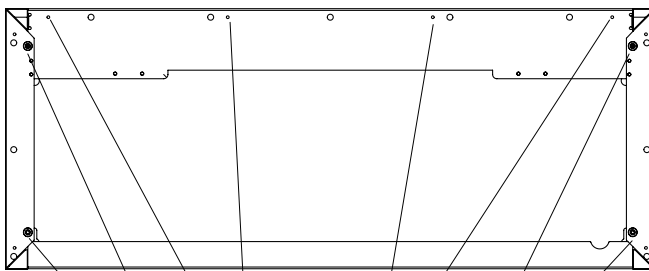

Fig. A



(4) M4 x 8 screws go here

(4) 3/16 x 3/8" screws go here

Fig. B

Mounting the Bracket and Baffle Filter

1. Insert the charcoal filter bracket into back side of baffle filter (side without handles). The (2) tabs on the bottom of the bracket should be inserted into the baffle filter first. Push the bracket towards the baffle filter to lock bracket in place. There is a clip on top of the bracket that will secure it to the baffle filter. (Fig. C) Repeat this step for each bracket.

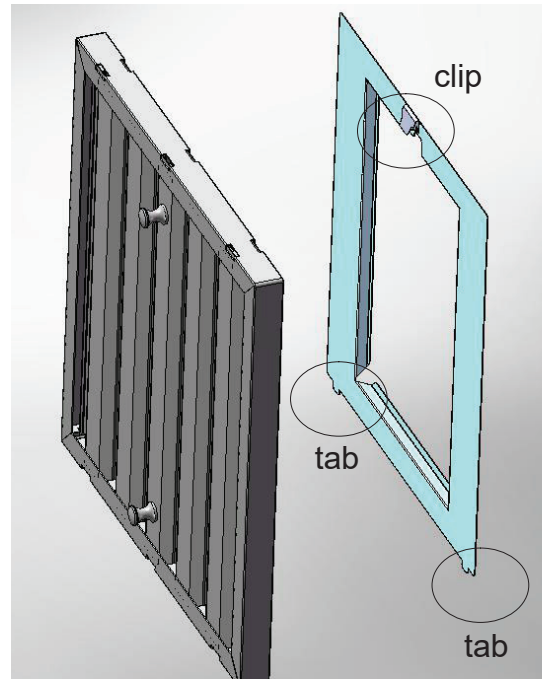

Fig. C

Mounting the Bracket and Charcoal Filter

1. First insert the tab cut out on the charcoal filter onto either side of the tab insert on the bracket, then clip the self locking tabs onto the bracket.
2. Insert the charcoal filter into the bracket. Tab cut-out side of the charcoal filter should be installed first then push down on the filter to lock in place. (Fig. D)

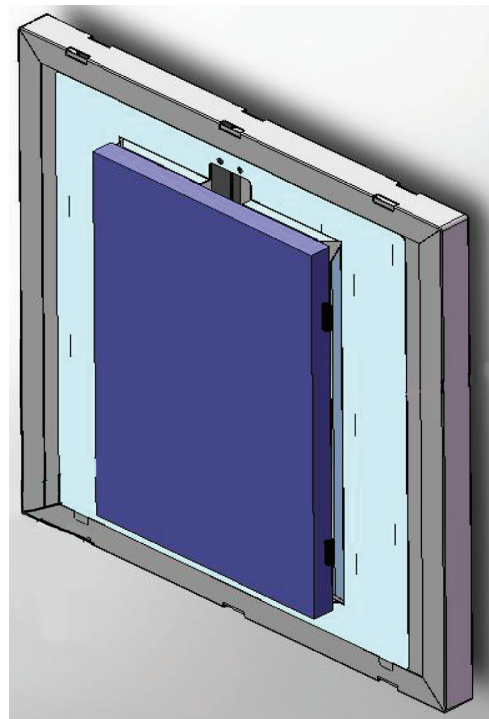

Fig. D