

HALL TREE

Assembly Instructions-Please keep for future reference

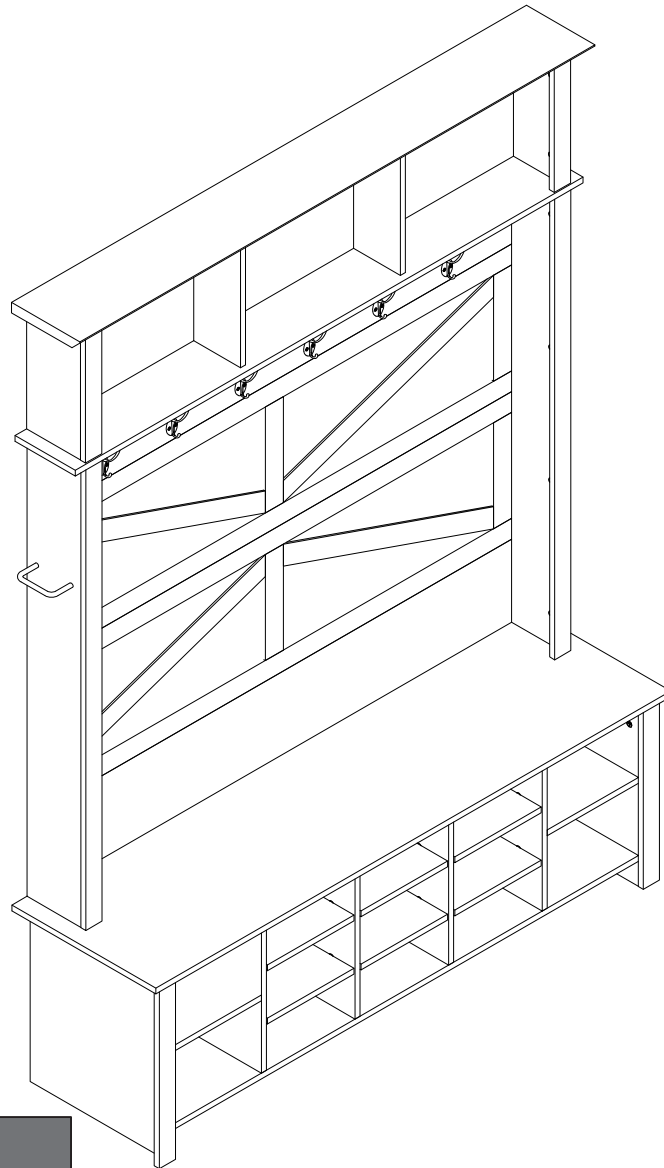

Dimensions

Width-15.74inch

Depth-56.29inch

Height-75inch



WARNING



This product is NOT a Clothing Storage Unit (CSU).
DO NOT use it for clothing storage.
Improper use may cause furniture tipover.

Important - Please read these instructions fully before starting assembly



Safety and Care Advice

Important – Please read these instructions fully before starting assembly

- Check you have all the components and tools listed on the following pages.
- Remove all fittings from the plastic bags and separate them into their groups.
- Keep children and animals away from the work area, small parts could choke if swallowed.
- Make sure you have enough space to layout the parts before starting.

- During assembly do not stand or put weight on the product, this could cause damage.
- Assemble the item as close to its final position (in the same room) as possible.
- Assemble on a soft level surface to avoid damaging the unit or your floor.
- Parts of the assembly will be easier with 2 people.



- To reduce the likelihood of damaging your product please ensure that your power drill is set on a low torque setting.

Care and maintenance

- Only clean using a damp cloth and mild detergent, do not use bleach or abrasive cleaners.
- From time to time check that there are no loose screws on this unit.
- This product should not be discarded with household waste. Take to your local authority waste disposal centre.

Handy Hints

- Assemble all parts and bolts loosely during assembly, only once the product is complete should you fully tighten the bolts
- Regularly check and ensure that all bolts and fittings are tightened properly.

WARNING In order to help prevent overturning – follow these instructions

To help prevent product toppling over please follow the below steps:-

- Use the anti tip stap or wall fixing method provided (if applicable)
- Do not allow children to climb or hang on the furniture
- Do not open more than one drawer at a time
- Do not place heavy items in the top drawers
- Do not place heavy items on top of the furniture, unless the furniture has been designed for this purpose

Using Camlocks

Step 1

Connect the male camlock as directed in the assembly instructions using a screwdriver.

1

DO NOT OVER TIGHTEN.
NE PAS SERRER EXCESSIVEMENT.

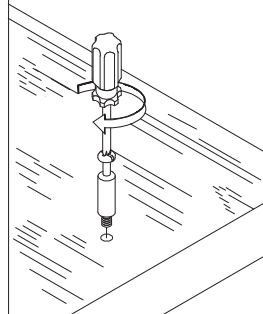

Step 2

Push the male camlock into the entry hole.

2

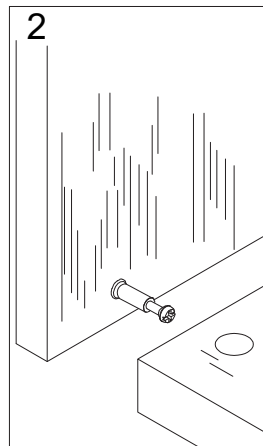

Step 3

Insert the female camlock as shown in the instruction.

Note: ensure that the arrow on the top of the camlock points towards the entry hole for the male camlock

3

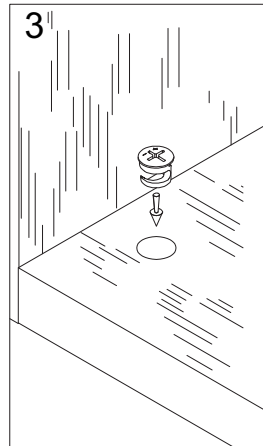

Step 4

Turn the female camlock clockwise with a screwdriver

You should feel a click when the camlock is locked in place.

The joint is now secure.

4

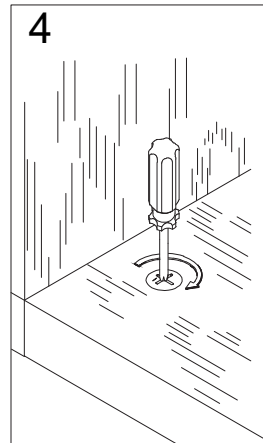



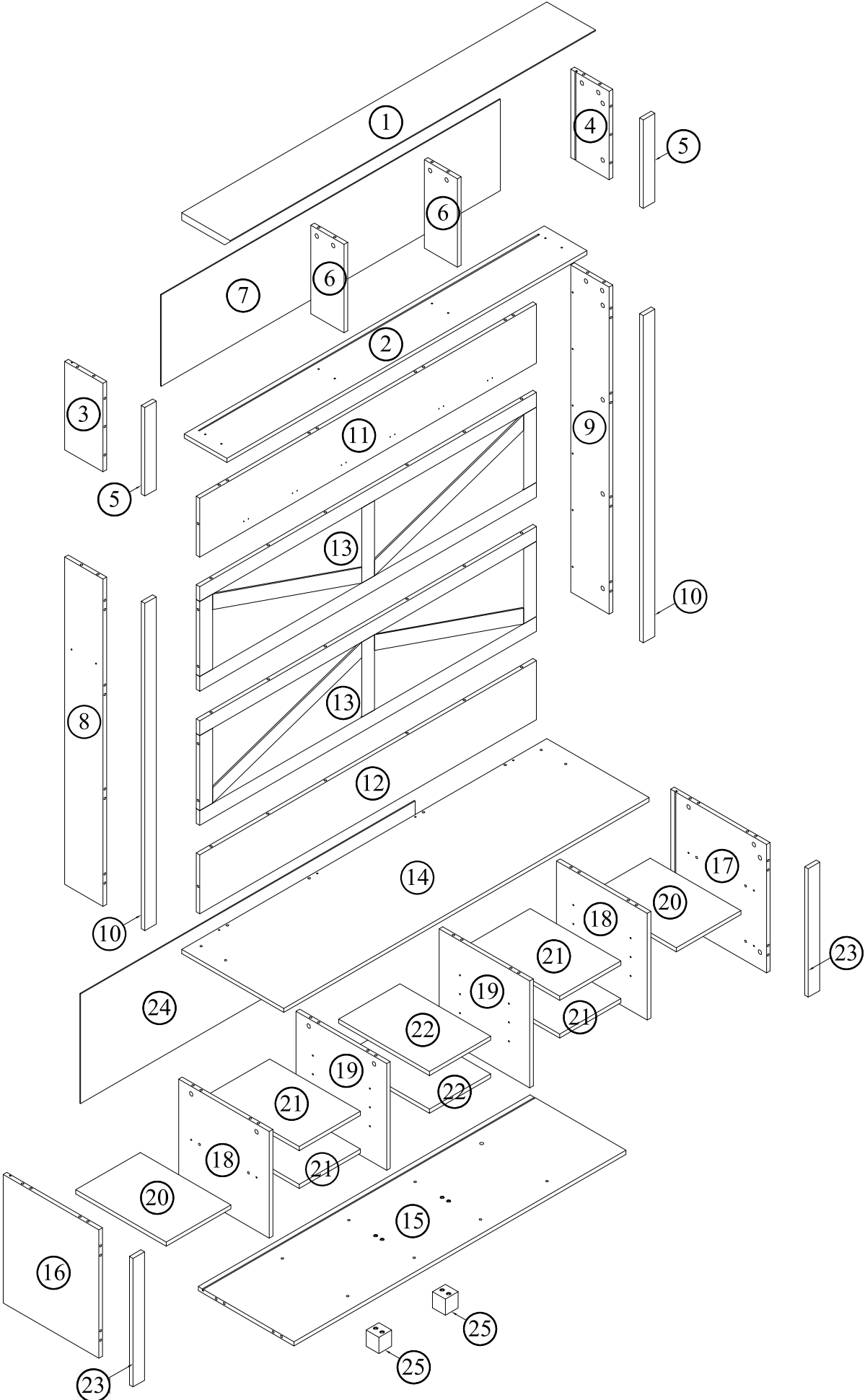





Assembly Instructions

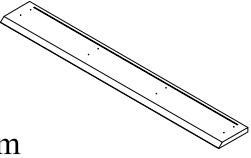
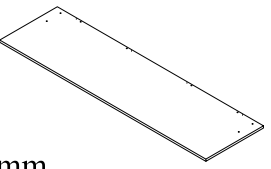
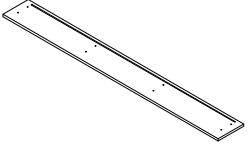
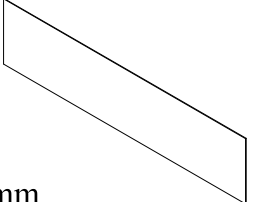

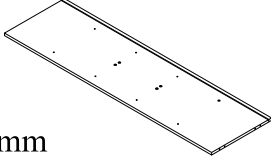
Assembly Instructions

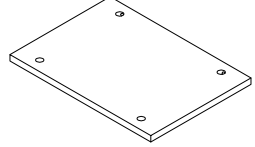
There are 2 boxes of this product

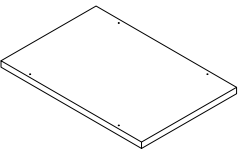

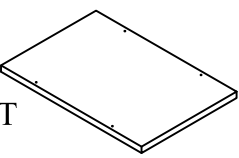
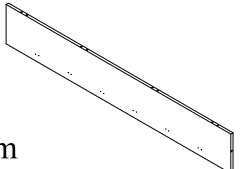
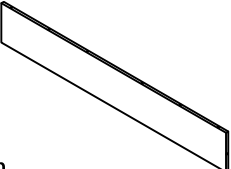
BOX-1 : N721P460893

①	ROOF BOARD  1430 x 190 x 25mm	1PC	⑭	FLAT BOARD OF LOWER CABINET  1430 x 400 x 14mm	1PC
②	FIXED PARTITION BOARD OF UPPER CABINET  1410 x 167 x 14mm	1PC	⑦	BACK BOARD OF UPPER CABINET  1328 x 310 x 2.5mm	1PC
⑧	LEFT VERTICAL BOARD OF MIDDLE CABINET  1110 x 150 x 14mm	1PC	⑮	BASEBOARD OF LOWER CABINET  1300 x 375 x 14mm	1PC
⑨	RIGHT VERTICAL BOARD OF MIDDLE CABINET  1110 x 150 x 14mm	1PC	⑳	LEFT RIGHT FIXED SHELT OF LOWER CABINET  355 x 253 x 14mm	2PCS
⑩	FRONT DECORATION OF MIDDLE CABINET  1110 x 150 x 14mm	2PCS	㉑	LEFT RIGHT REMOVABLE SHELT OF LOWER CABINET  355 x 240 x 14mm	4PCS
⑤	FRONT DECORATION OF UPPER CABINET  300 x 45 x 14mm	2PC	㉒	MIDDLE REMOVABLE SHELT OF LOWER CABINET  355 x 240 x 14mm	2PCS
⑪	TOP BACKBOARD OF MIDDLE CABINET  1218 x 200 x 14mm	1PC	⑫	BOTTOM BACKBOARD OF MIDDLE CABINET  1218 x 200 x 14mm	1PC
				HARDWARE KIT	1PC

Assembly Instructions

There are 2 boxes of this product

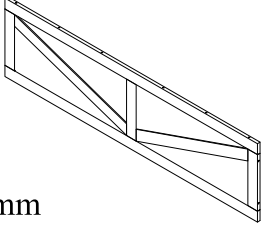
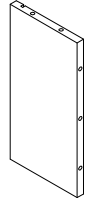
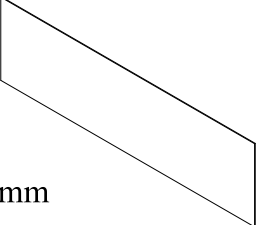
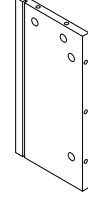
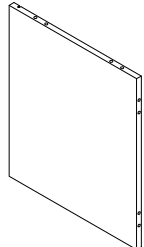

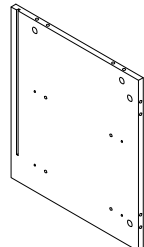
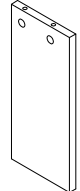
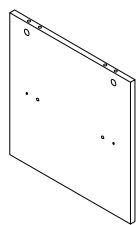
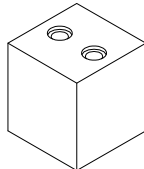
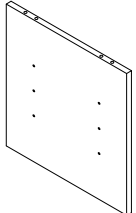



BOX-2: N721P460894

<p>⑬</p>	<p>MIDDLE BACK BOARD OF MIDDLE CABINET</p>  <p>1318 x 355 x 14mm</p>	<p>2PCS</p>	<p>③</p>	<p>LEFT VERTICAL BOARD OF UPPER CABINET</p>  <p>300 x 150 x 14mm</p>	<p>1PC</p>
<p>⑭</p>	<p>BACKBOARD OF LOWER CABINET</p>  <p>1310 x 372 x 2.5mm</p>	<p>1PC</p>	<p>④</p>	<p>RIGHT VERTICAL BOARD OF UPPER CABINET</p>  <p>300 x 150 x 14mm</p>	<p>1PC</p>
<p>⑮</p>	<p>LEFT VERTICAL BOARD OF LOWER CABINET</p>  <p>436 x 375 x 14mm</p>	<p>1PC</p>	<p>⑲</p>	<p>DECORATION OF LOWER CABINET</p>  <p>436 x 45 x 14mm</p>	<p>2PCS</p>
<p>⑯</p>	<p>RIGHT VERTICAL BOARD OF LOWER CABINET</p>  <p>436 x 375 x 14mm</p>	<p>1PC</p>	<p>⑥</p>	<p>MIDDLE VERTICAL BOARD OF UPPER CABINET</p>  <p>300 x 130 x 14mm</p>	<p>2PCS</p>
<p>⑰</p>	<p>LEFT RIGHT MIDDLE VERTICAL BOARD OF LOWER CABINET</p>  <p>362 x 355 x 14mm</p>	<p>2PCS</p>	<p>⑳</p>	<p>MIDDLE FOOT SUPPORT BASEBOARD</p>  <p>50 x 50 x 55mm</p>	<p>2PCS</p>
<p>⑱</p>	<p>MIDDLE VERTICAL BOARD OF LOWER CABINET</p>  <p>362 x 355 x 14mm</p>	<p>2PCS</p>			

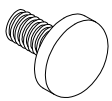
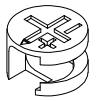
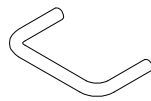
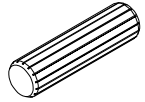
Components-Fittings

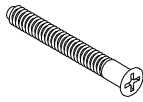
Please check you have all the panels listed below

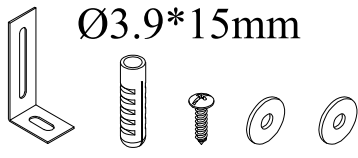
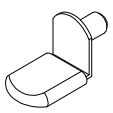
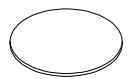
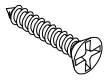
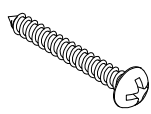
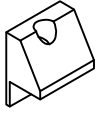
Note: The quantities below are the correct amount to complete the assembly. In some cases more fittings may be supplied than are required.

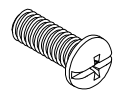
Ⓐ	Ø5*35 mm		72+4(PCS)	Ⓚ	Ø1/4*20 mm		2(PCS)
Ⓑ	Ø15*11 mm		72+4(PCS)	Ⓛ	106*60 mm		1(PCS)
Ⓒ	Ø8*30 mm		64+4(PCS)	Ⓜ	Ø5/32*17 mm		2(PCS)
Ⓓ	40*28 mm		6(PCS)	Ⓝ	M5*40 mm		20+2(PCS)
Ⓔ	Ø3.5*12 mm		12+1(PCS)	Ⓞ	72*15*25mm Ø3.9*15mm		2(PCS)
Ⓕ	15*19*16mm		24+1(PCS)	Ⓟ	Ø20*0.2mm		72(PCS)
Ⓖ	Ø3.5*15 mm		12+1(PCS)	Ⓠ	Ø3.9*30 mm		2(PCS)
Ⓗ	17.5*16*9.5mm		24(PCS)	Ⓡ	Ø2.9*18 mm		24+2(PCS)
				Ⓙ	Ø1/4*30 mm		4(PCS)

Step/Étape 1

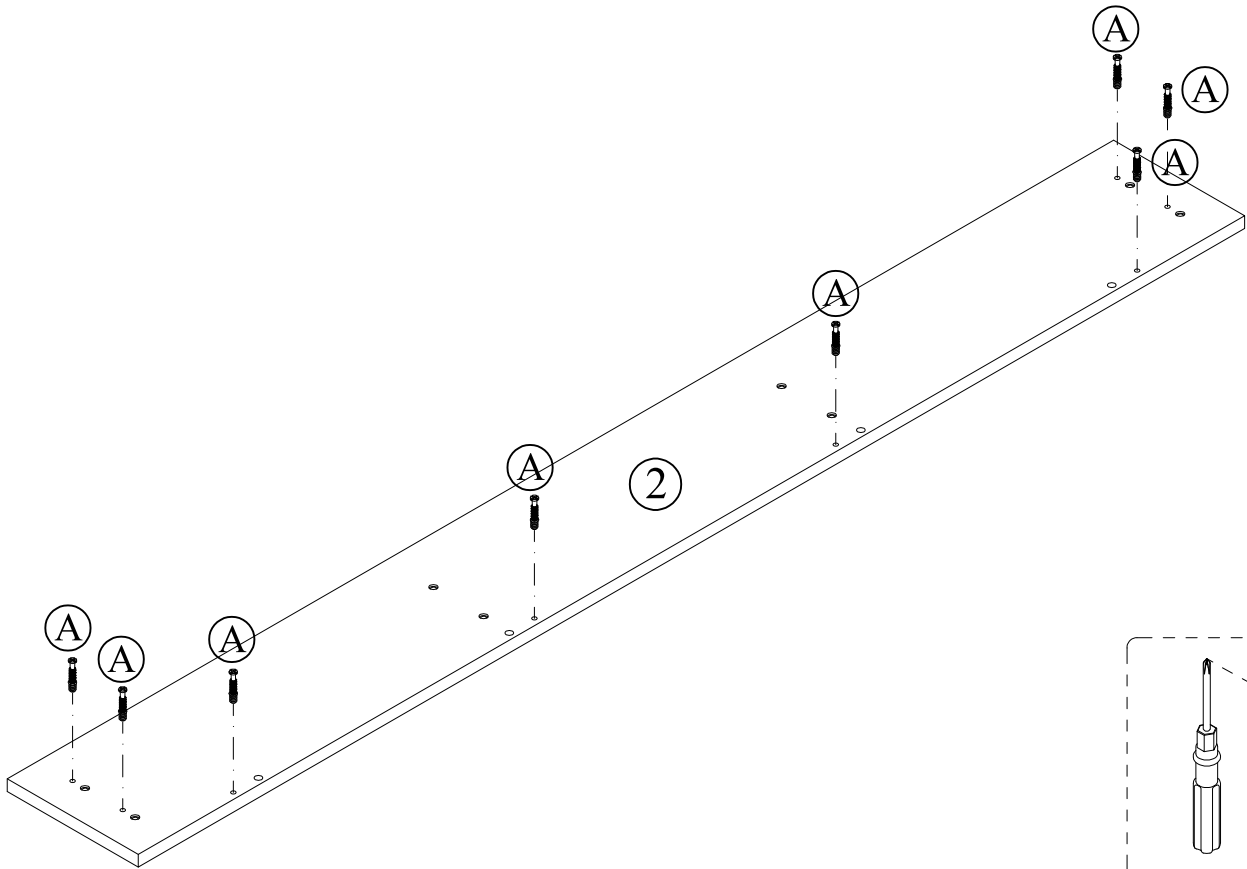
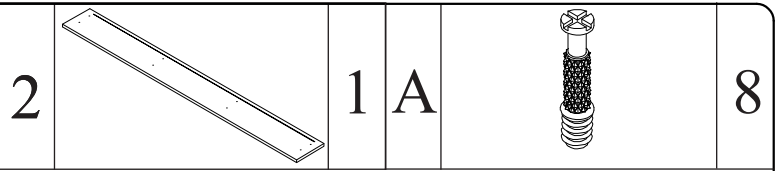

Step/Étape 2

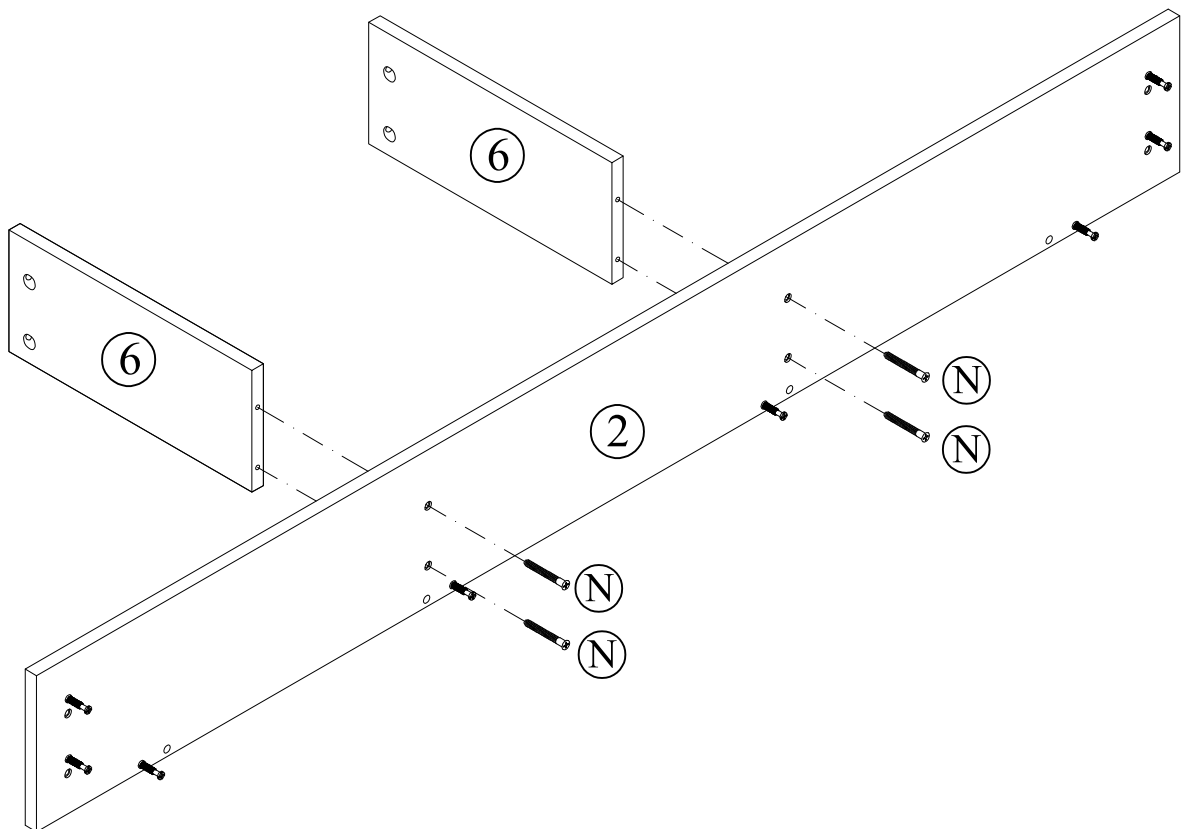
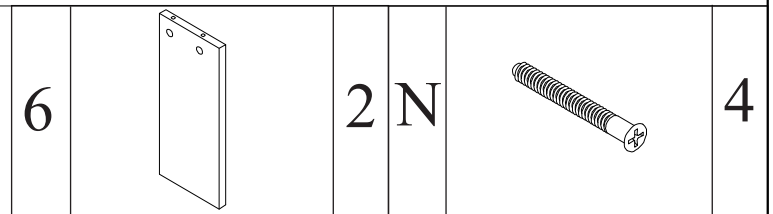

Step/Étape 3

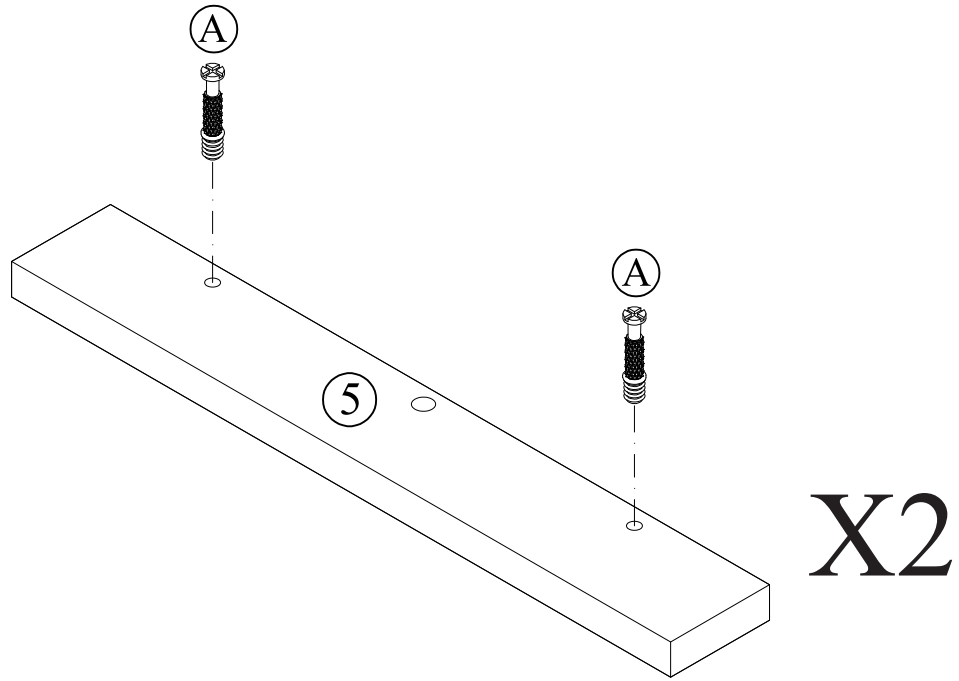
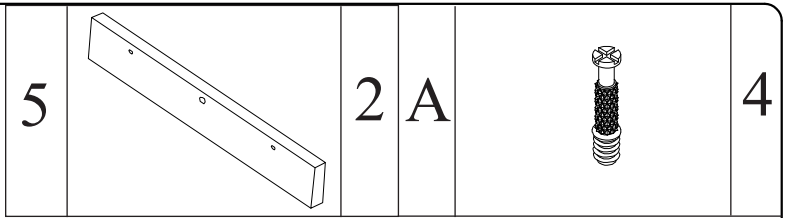

Step/Étape 4

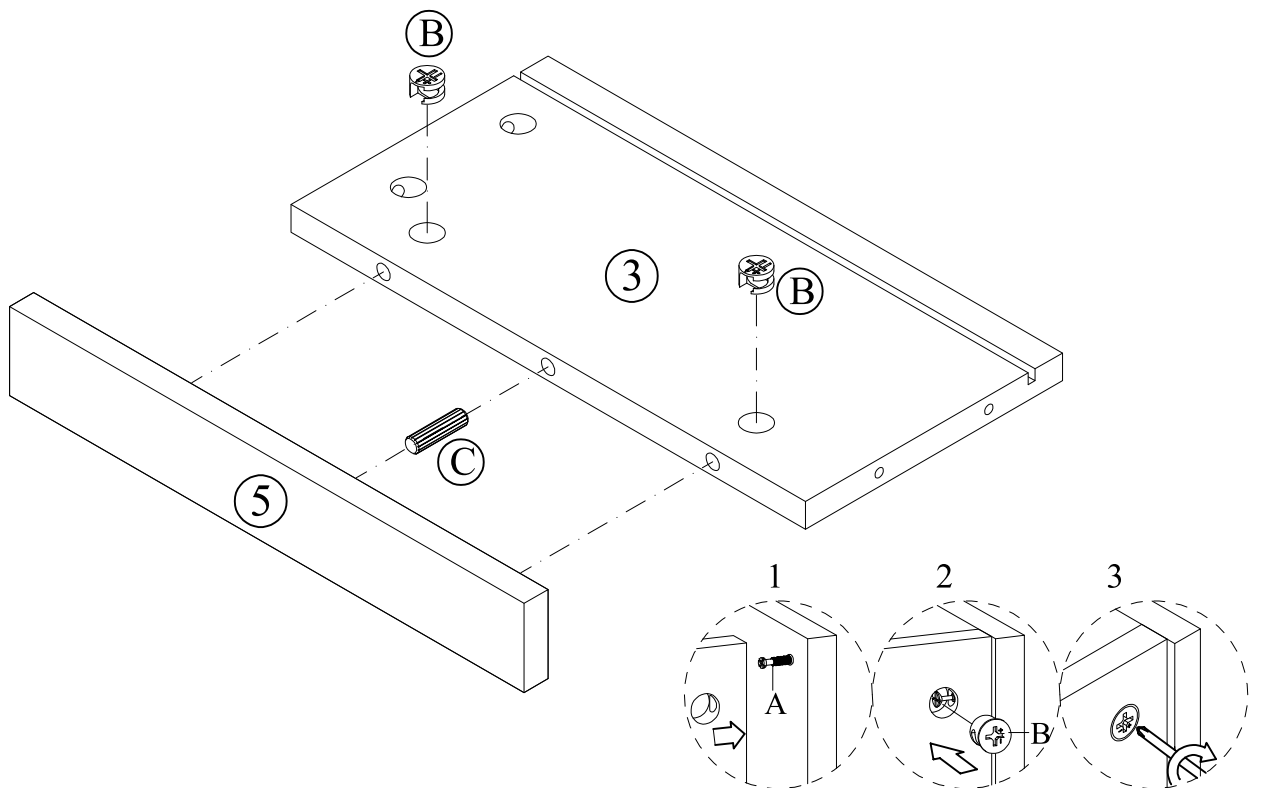
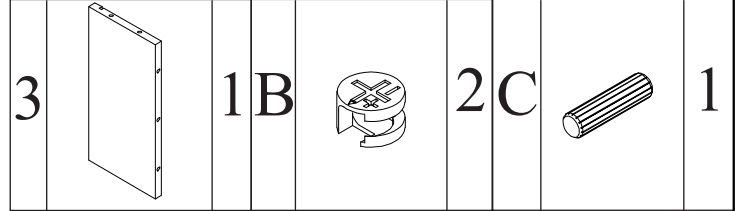

Step/Étape 5

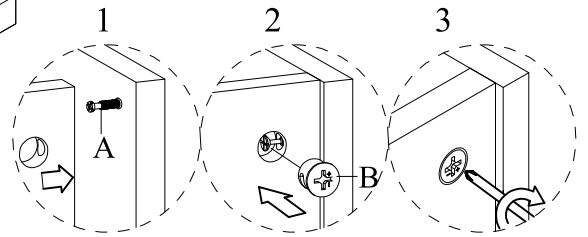
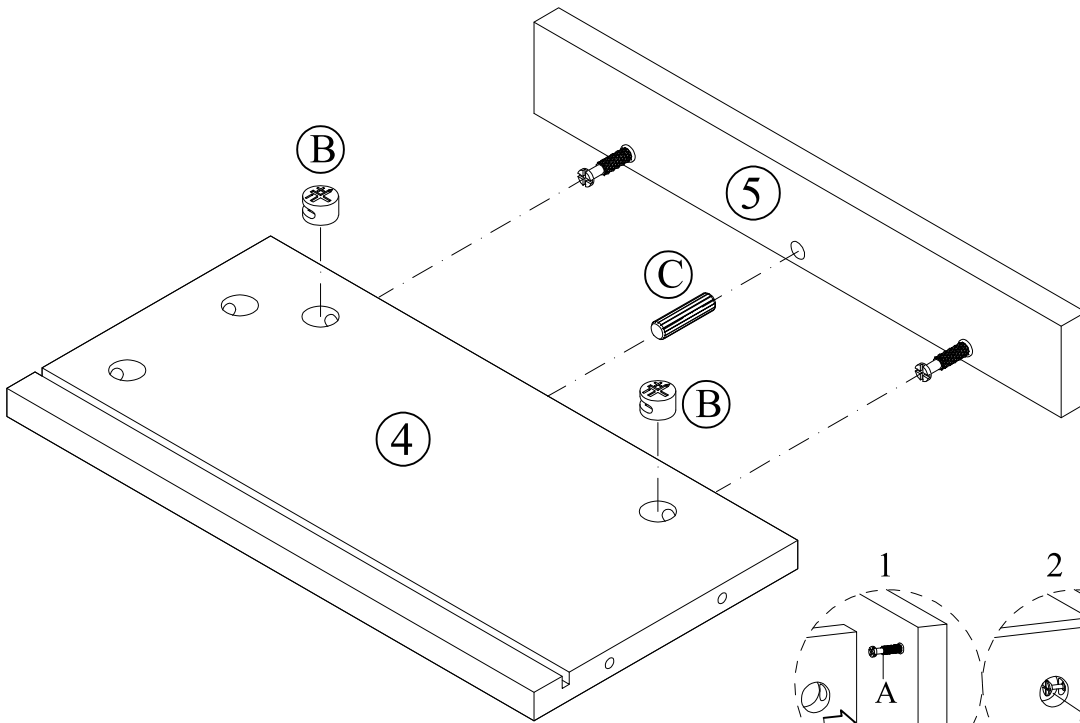
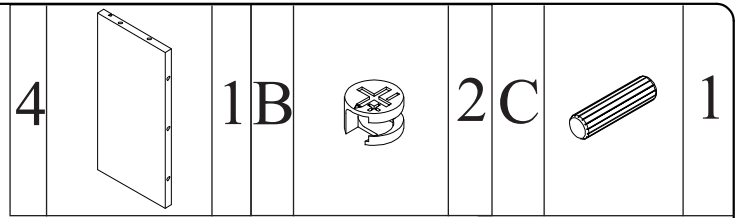

Step/Étape 6

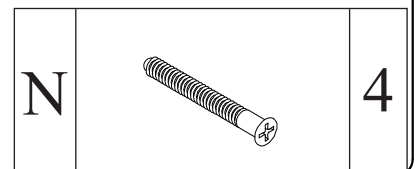
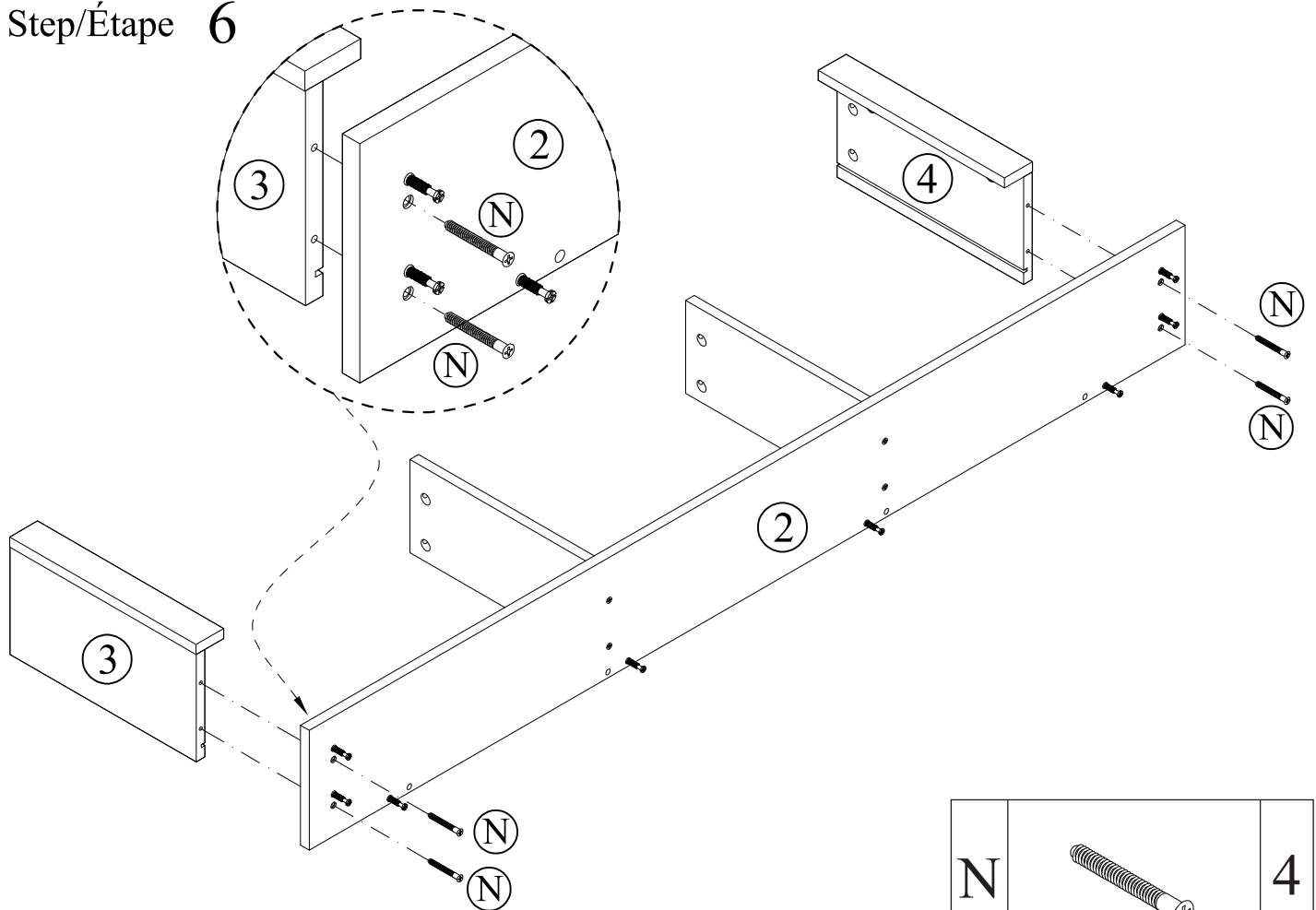

Step/Étape 7

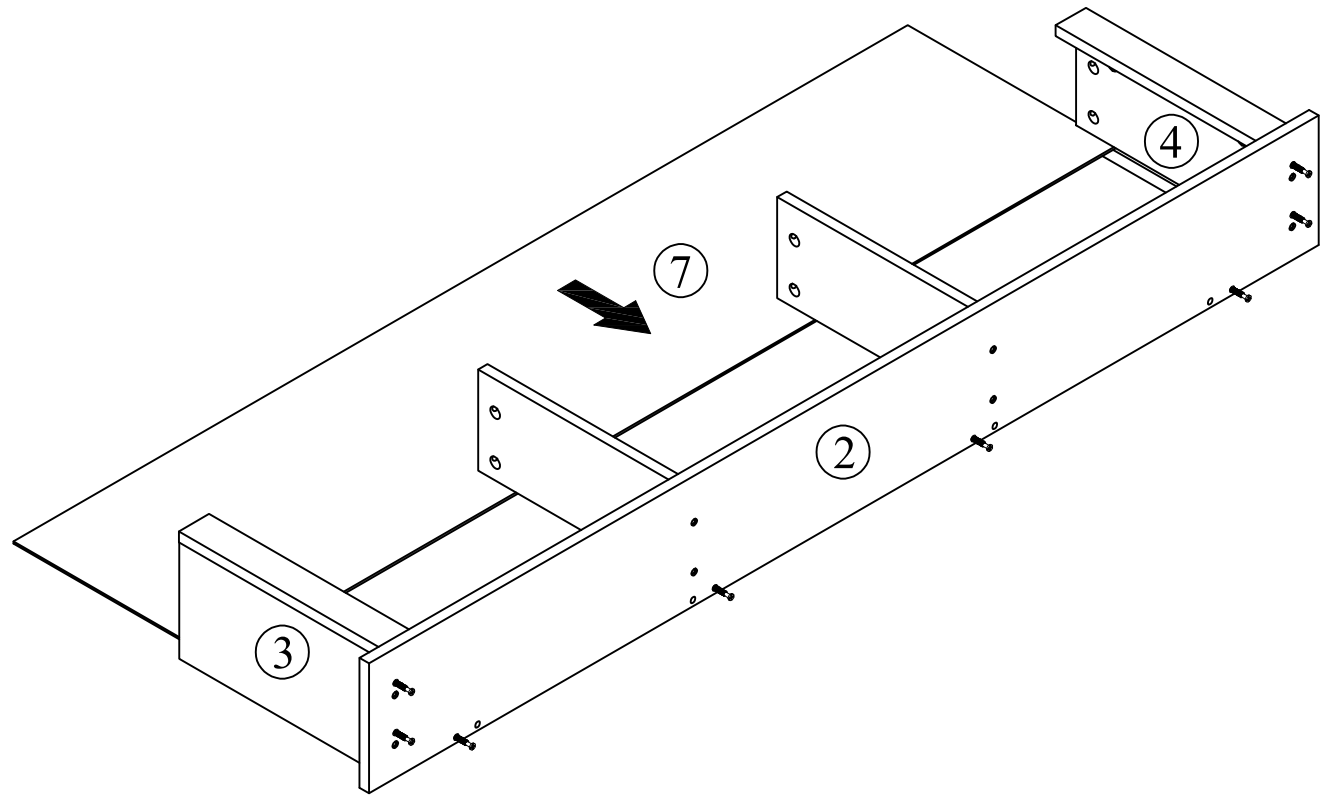

Step/Étape 8

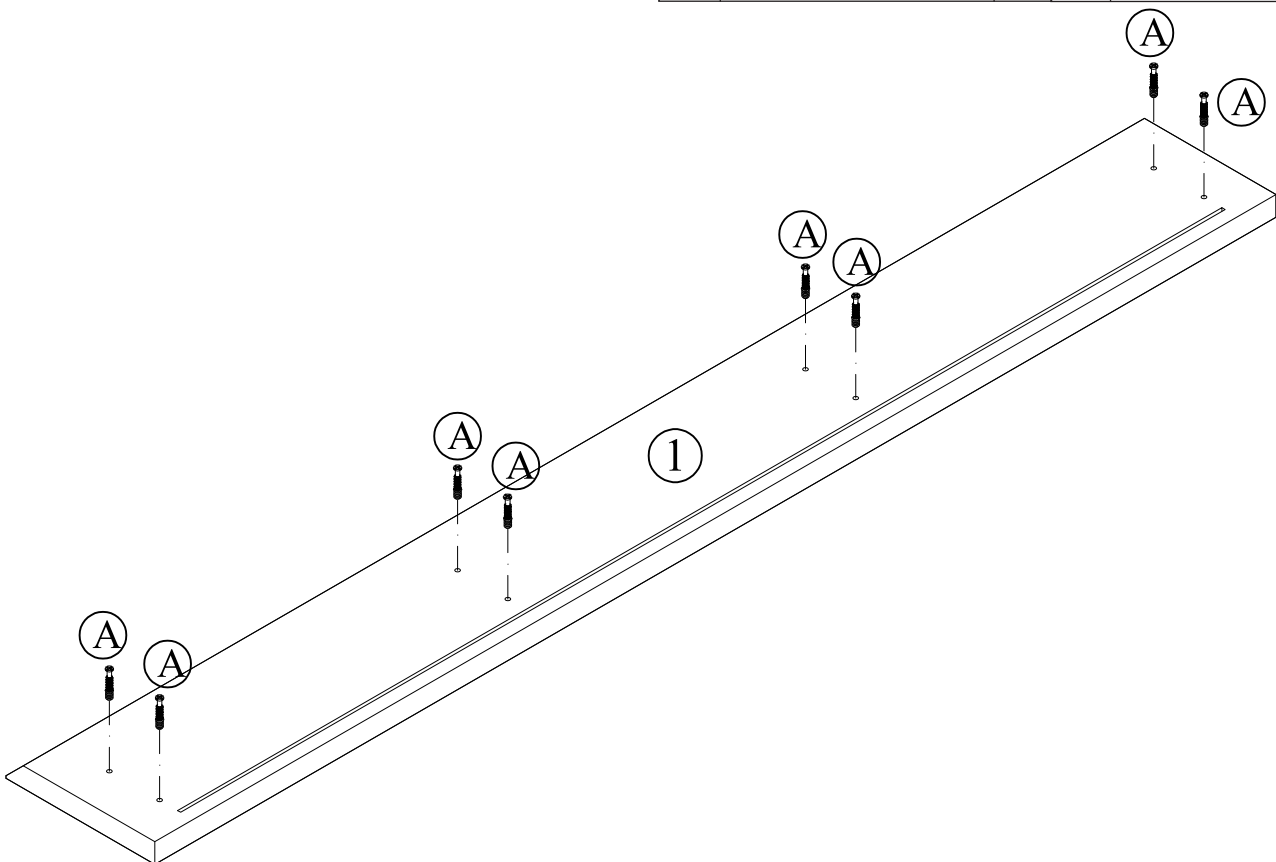
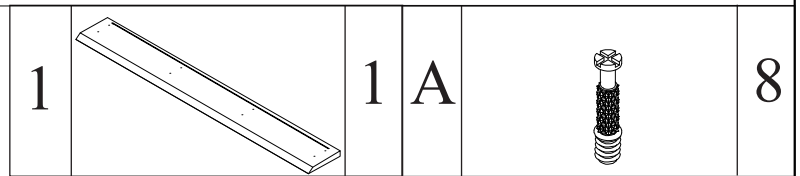

Step/Étape 9

B



8

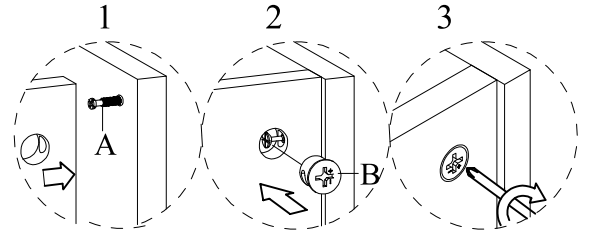
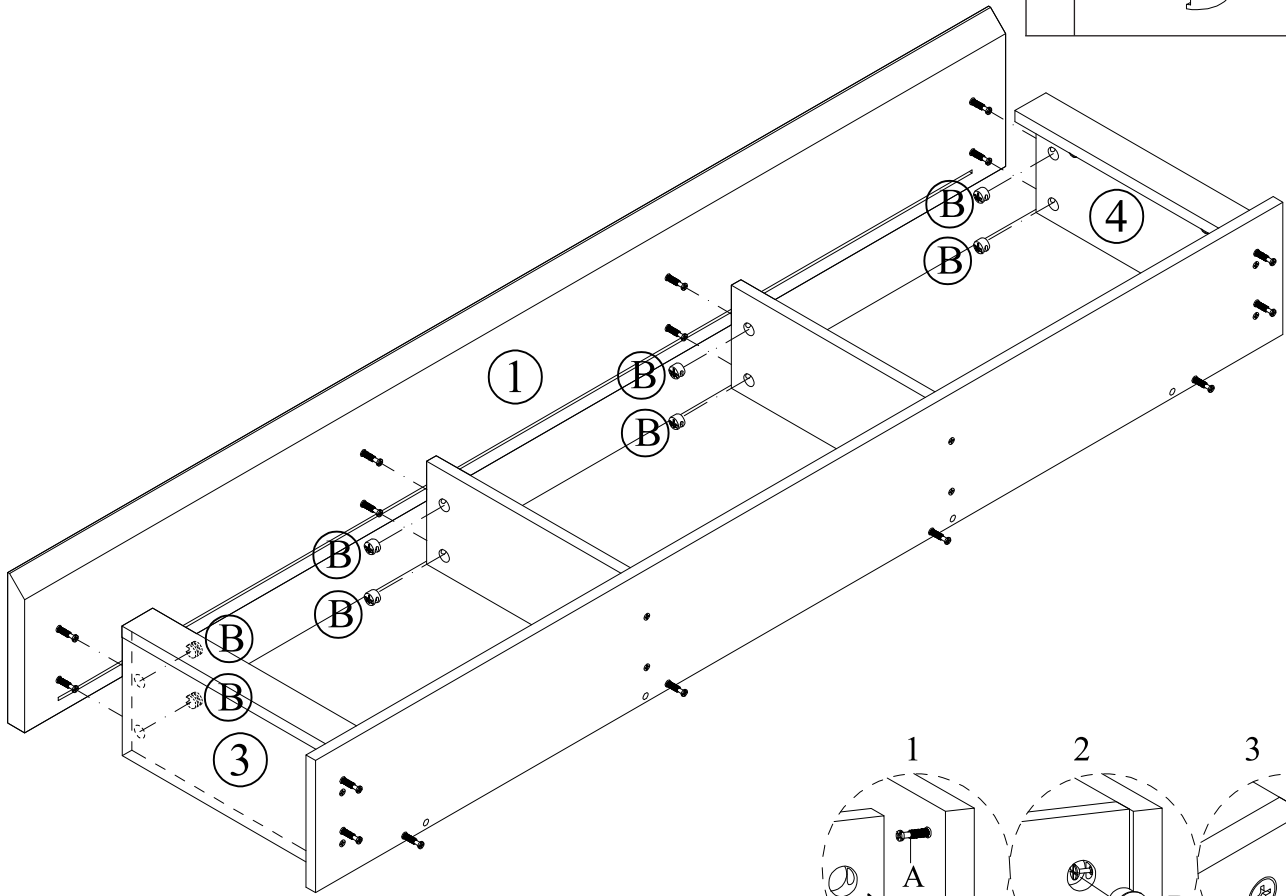

Step/Étape 10

10

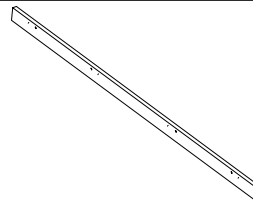

2 A



8

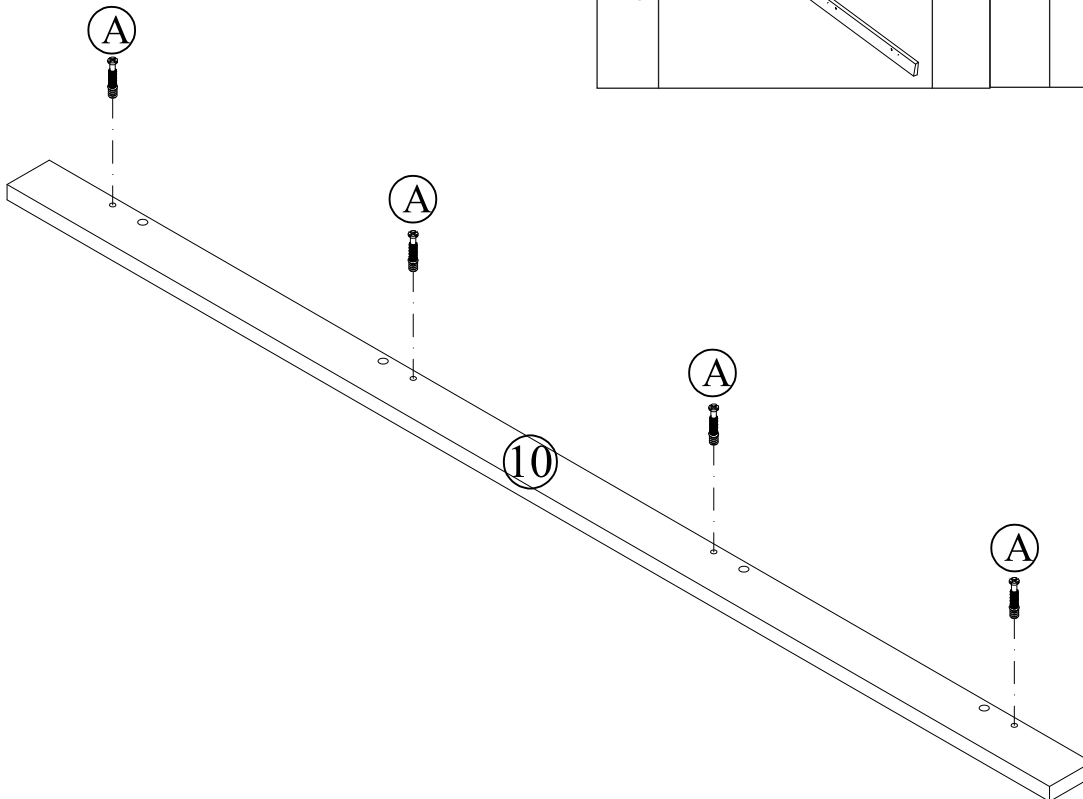

X2

Step/Étape 11

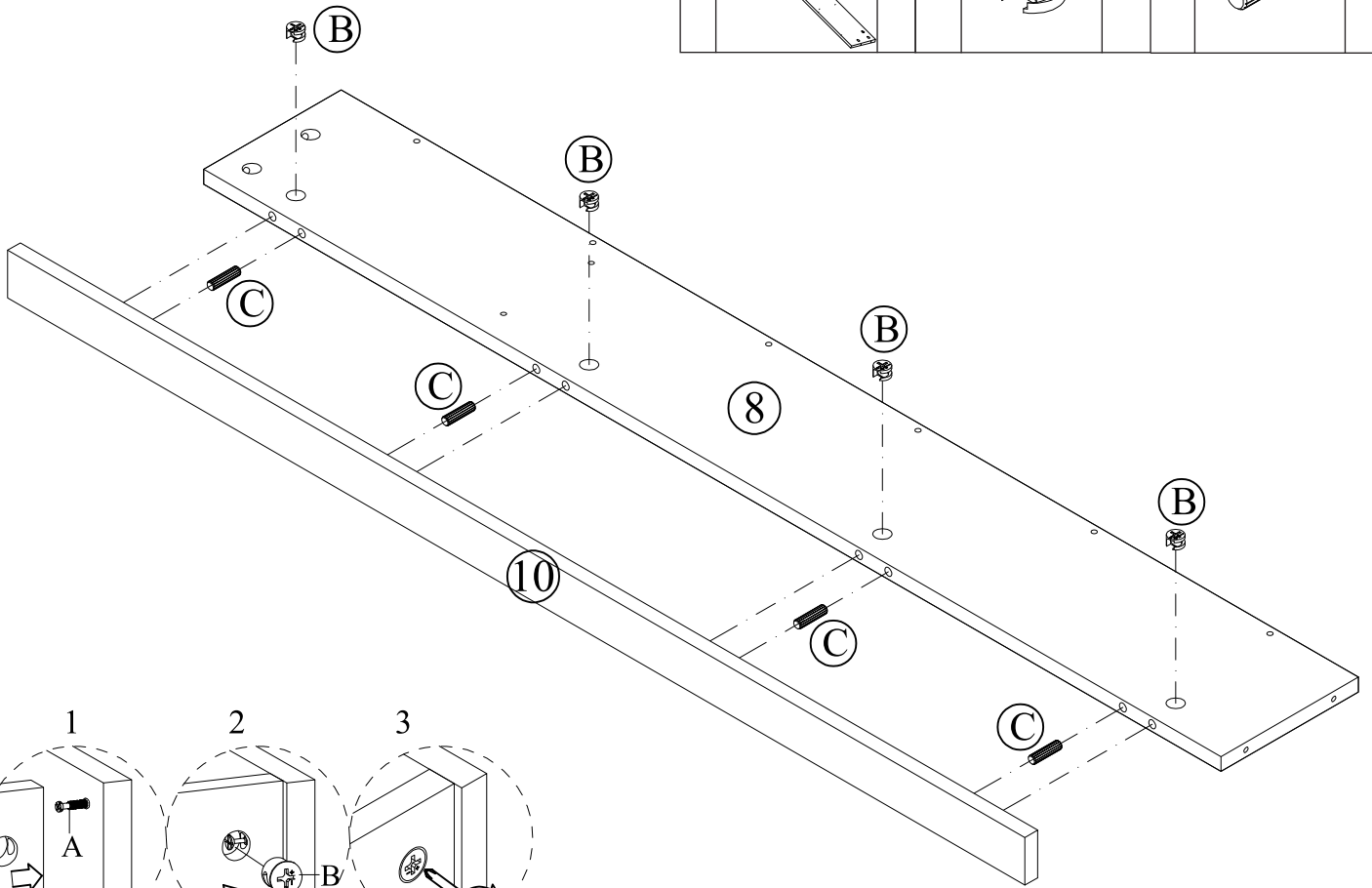
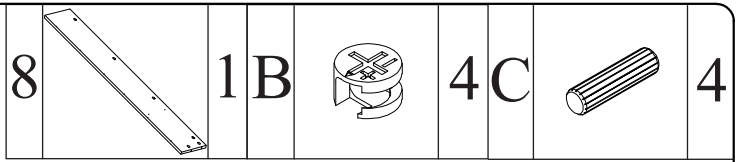

Step/Étape 12

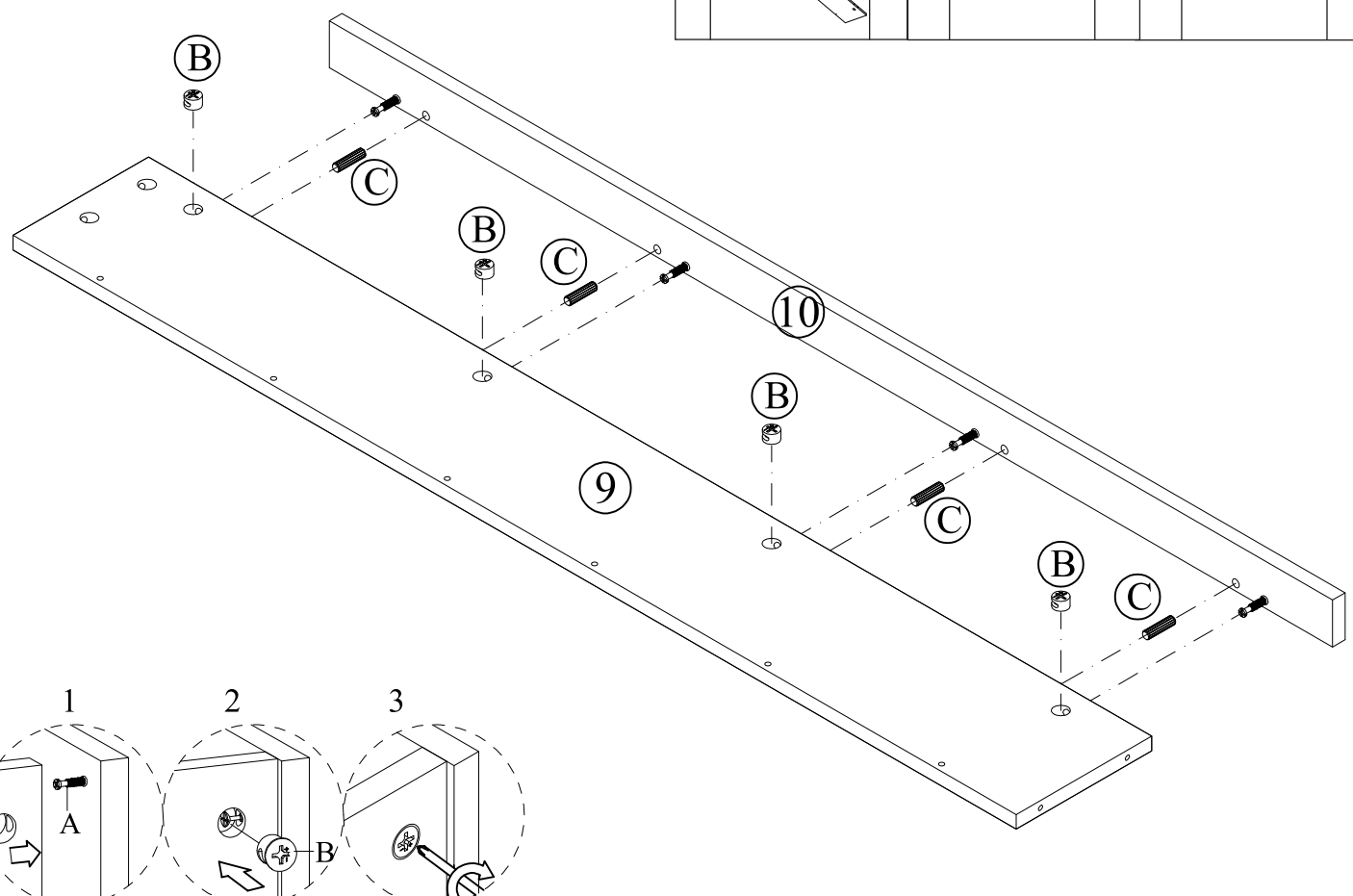
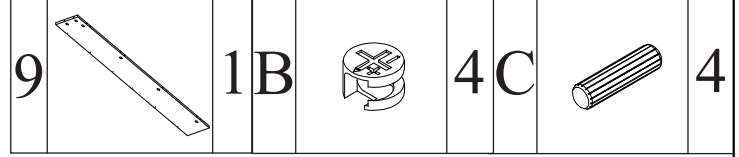

Step/Étape 13

A



6

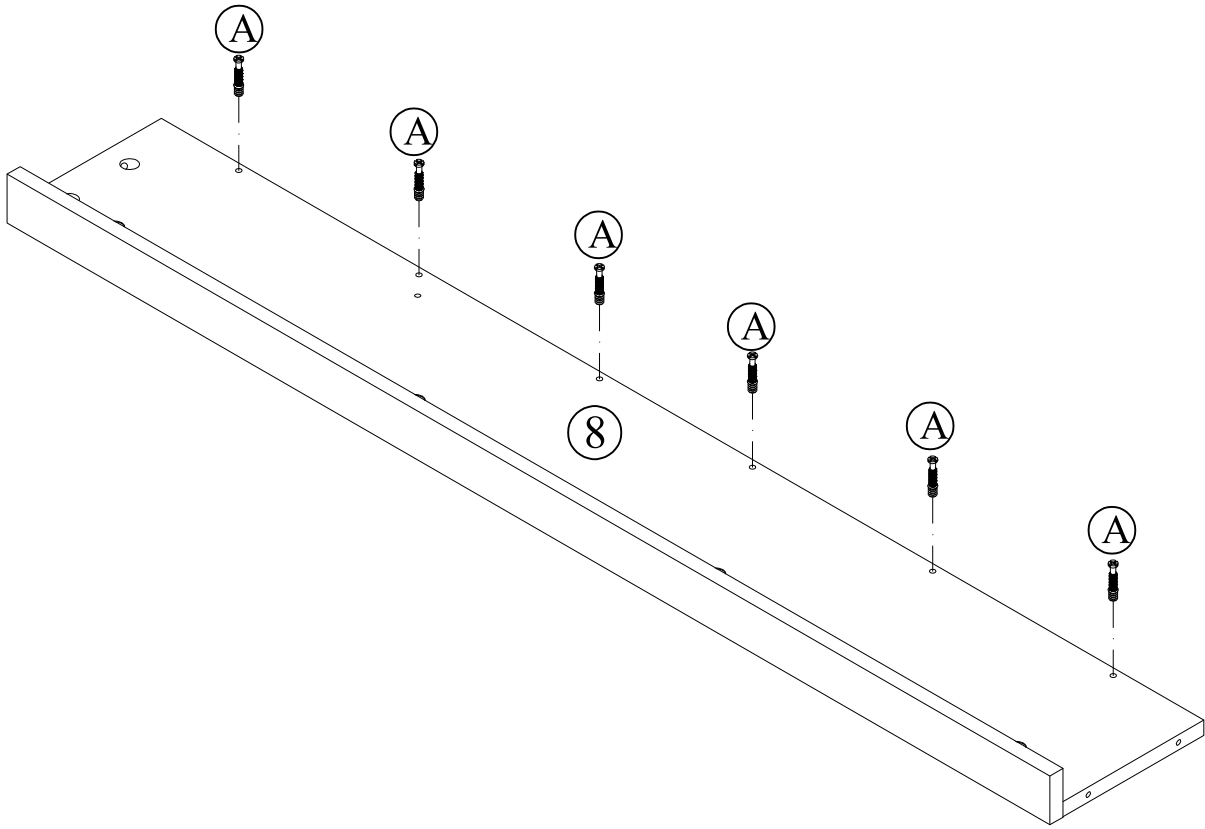

Step/Étape 14

A



6

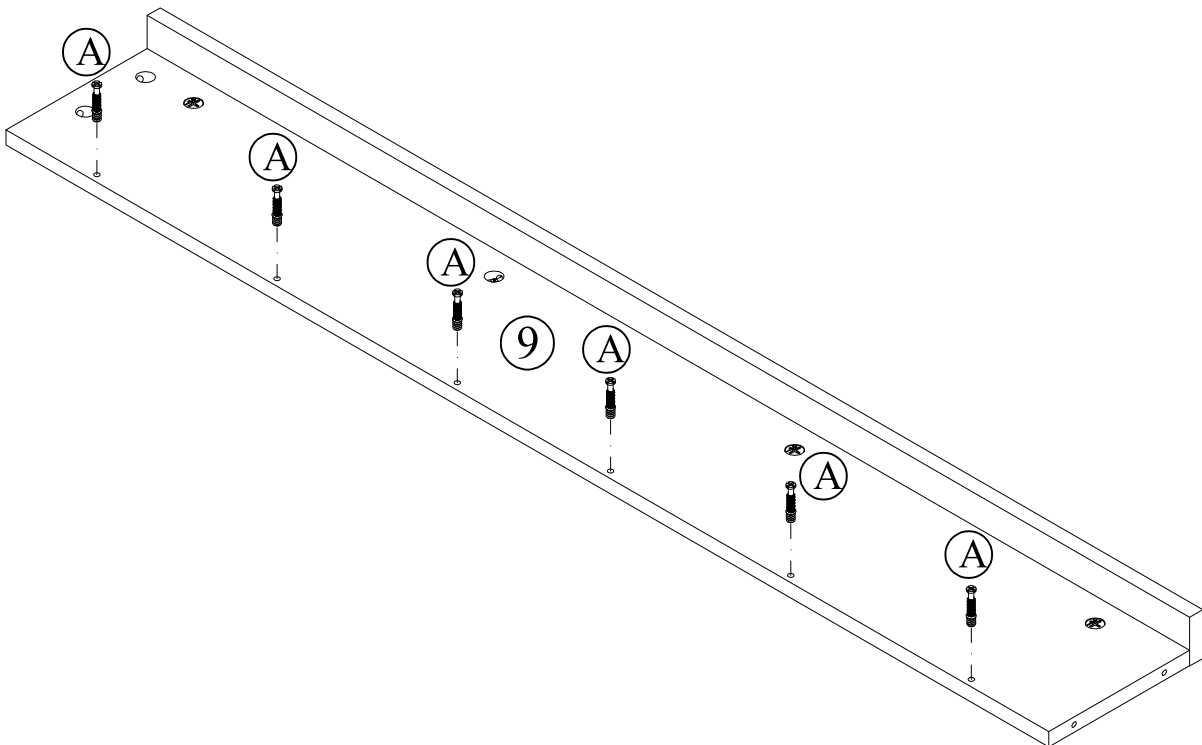

Step/Étape 15

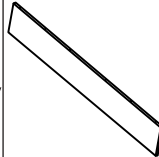
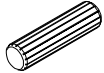
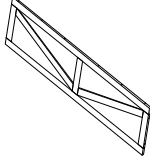
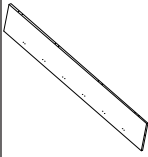

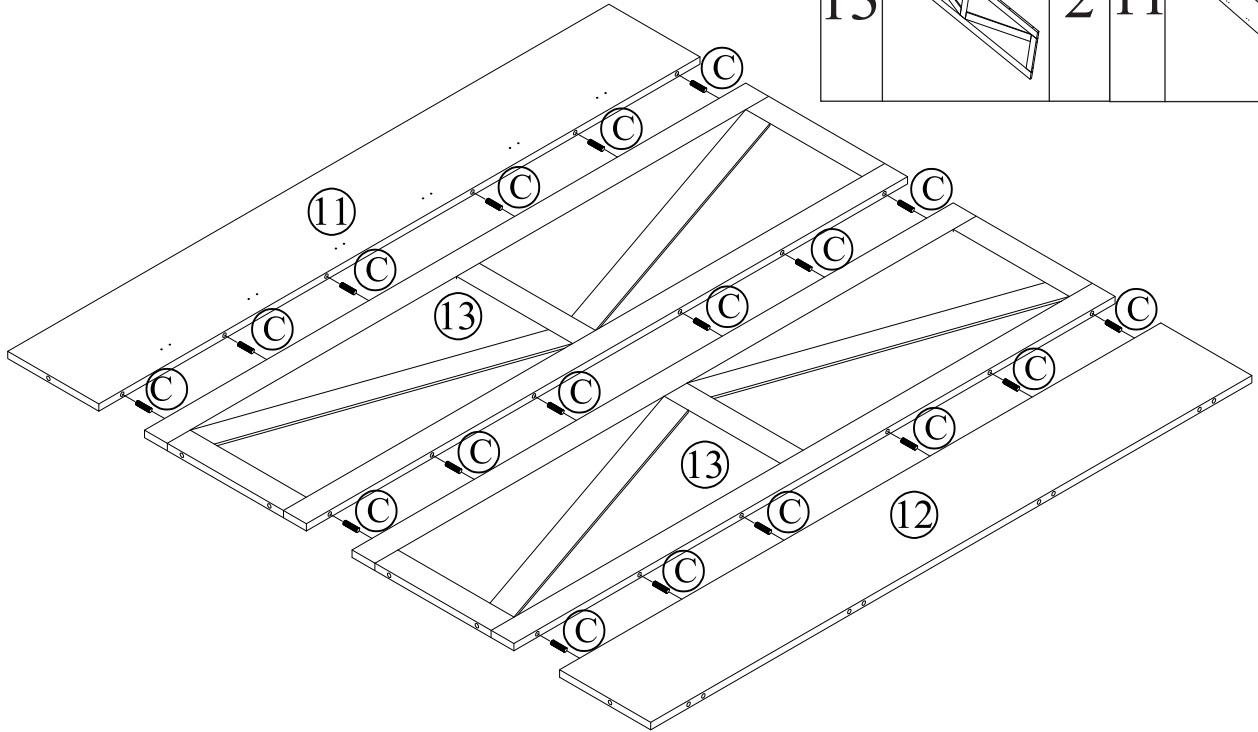
12		1 C		18
13		2 11		1

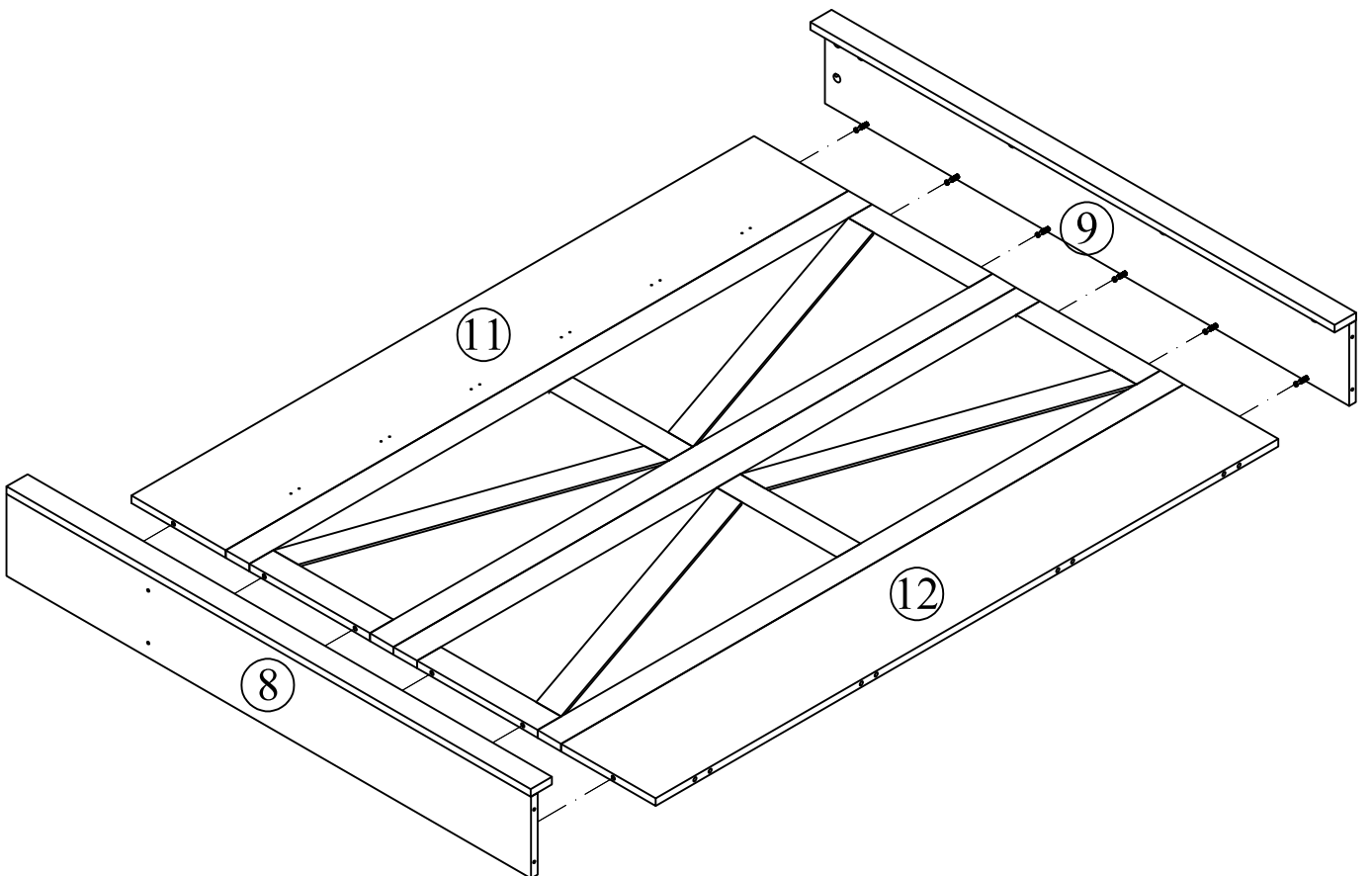

Step/Étape 16 Two people helped to stand up numbers 8 and 9 upright to prevent them from falling apart.



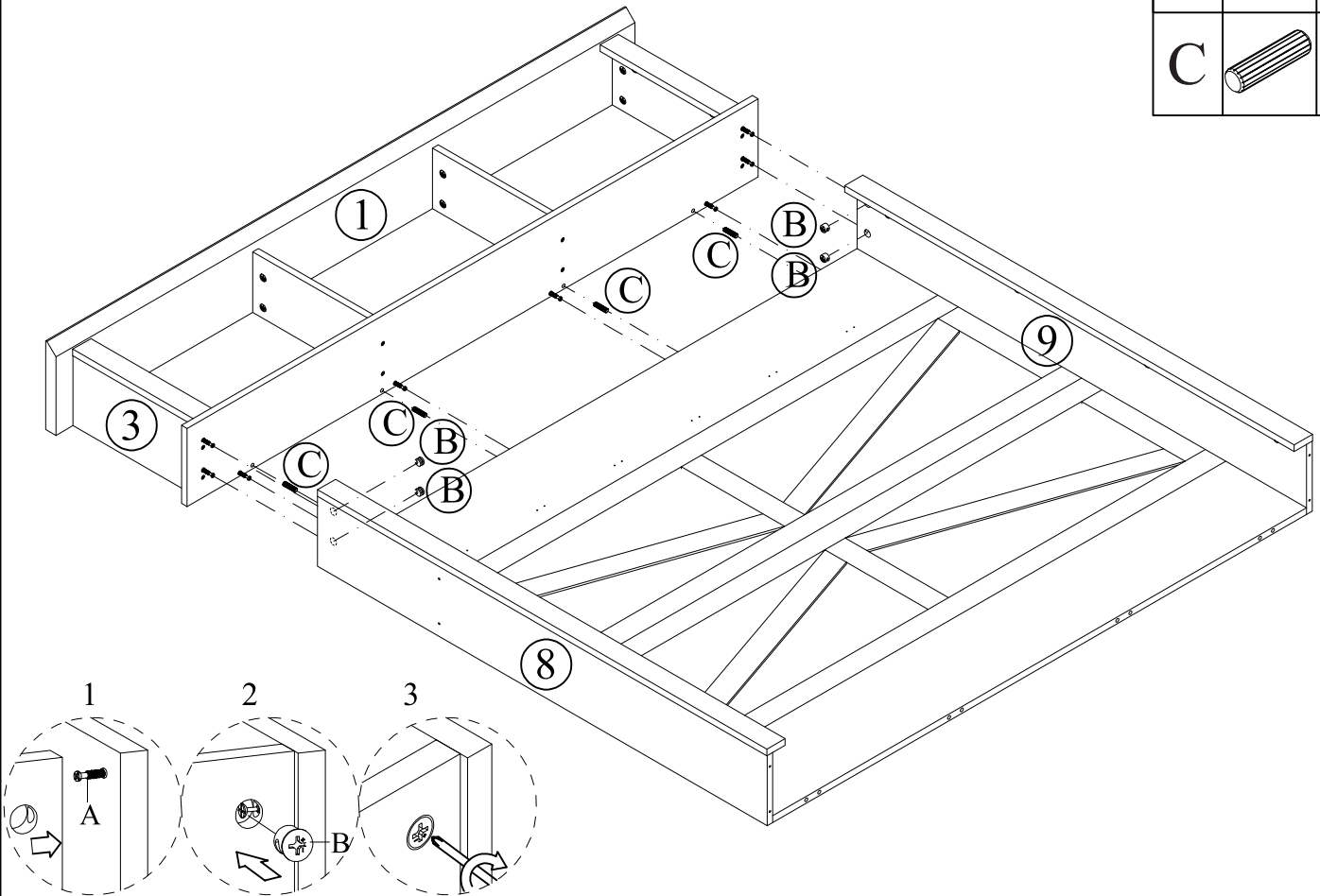

Step/Étape 17 Two people helped to stand up numbers 8 and 9 upright to prevent them from falling apart.

B		4
C		4

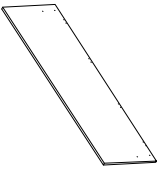

Step/Étape 18

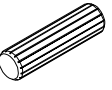
14		1 A		16C		4
----	-------------------------------------------------------------------------------------	-----	---------------------------------------------------------------------------------------	-----	---------------------------------------------------------------------------------------	---

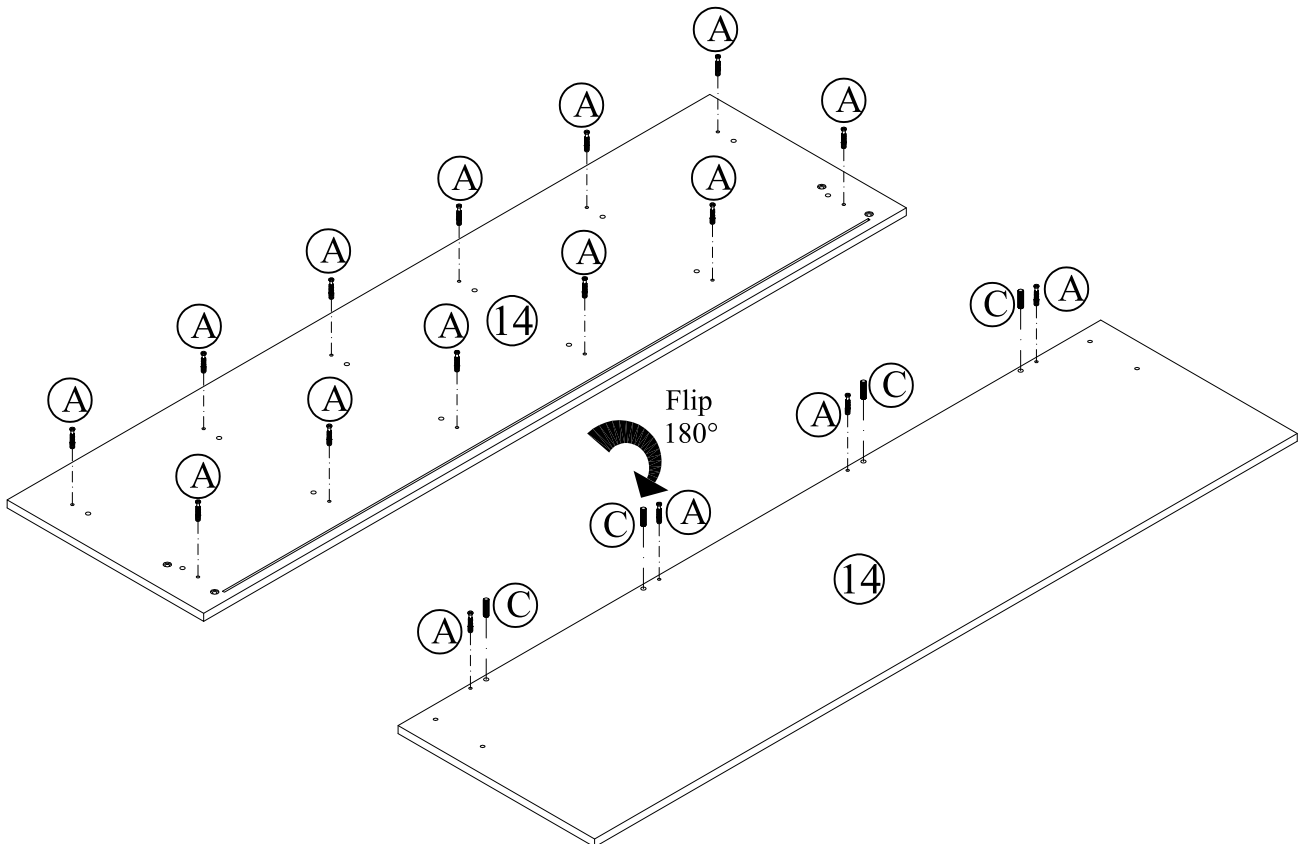



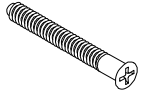

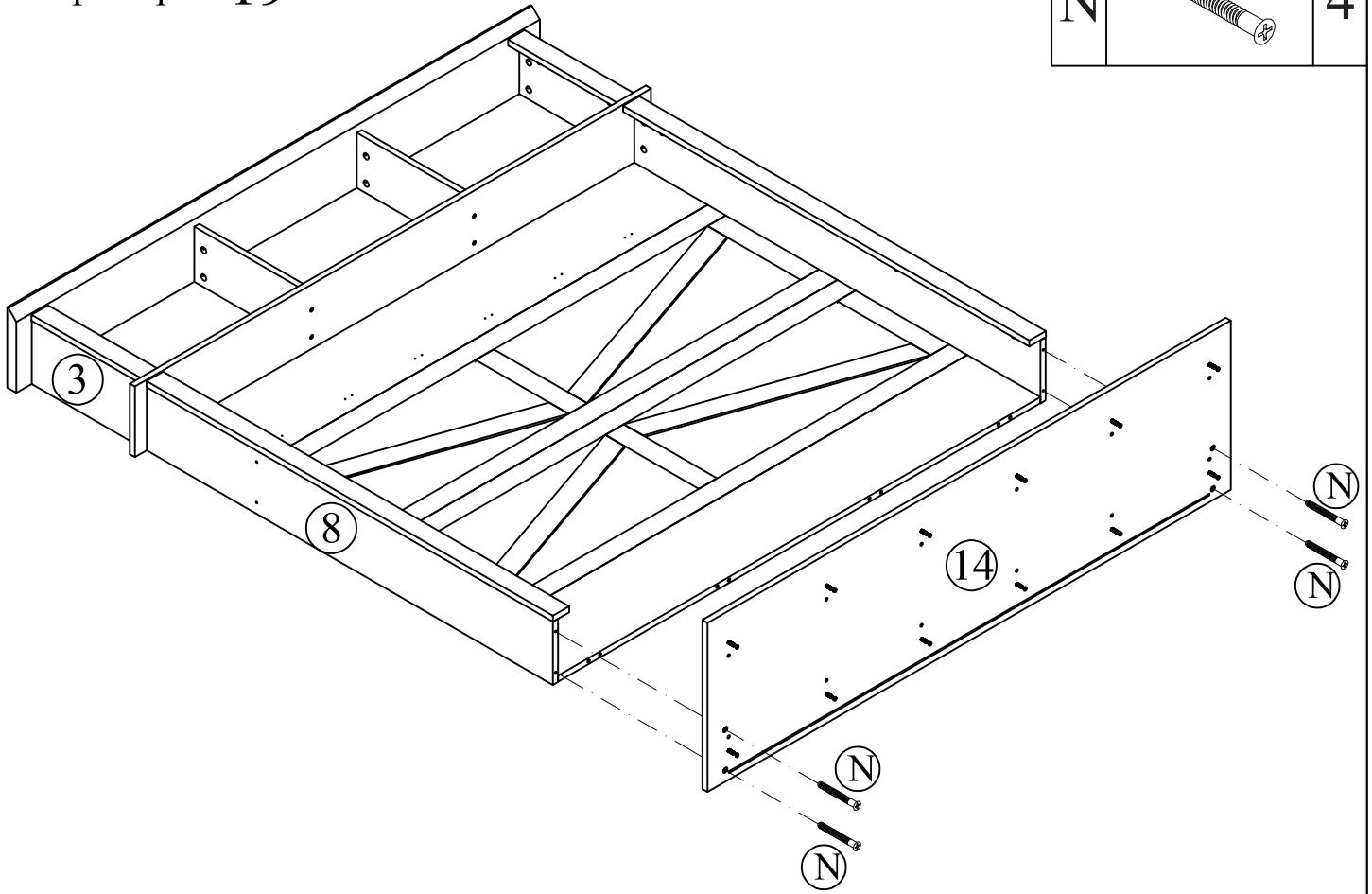
Step/Étape 19

N		4
---	------------------------------------------------------------------------------------	---

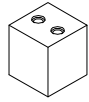

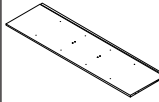
Step/Étape 20

25		2 J		4 15		1 K		2
----	-------------------------------------------------------------------------------------	-----	-------------------------------------------------------------------------------------	------	---------------------------------------------------------------------------------------	-----	---------------------------------------------------------------------------------------	---

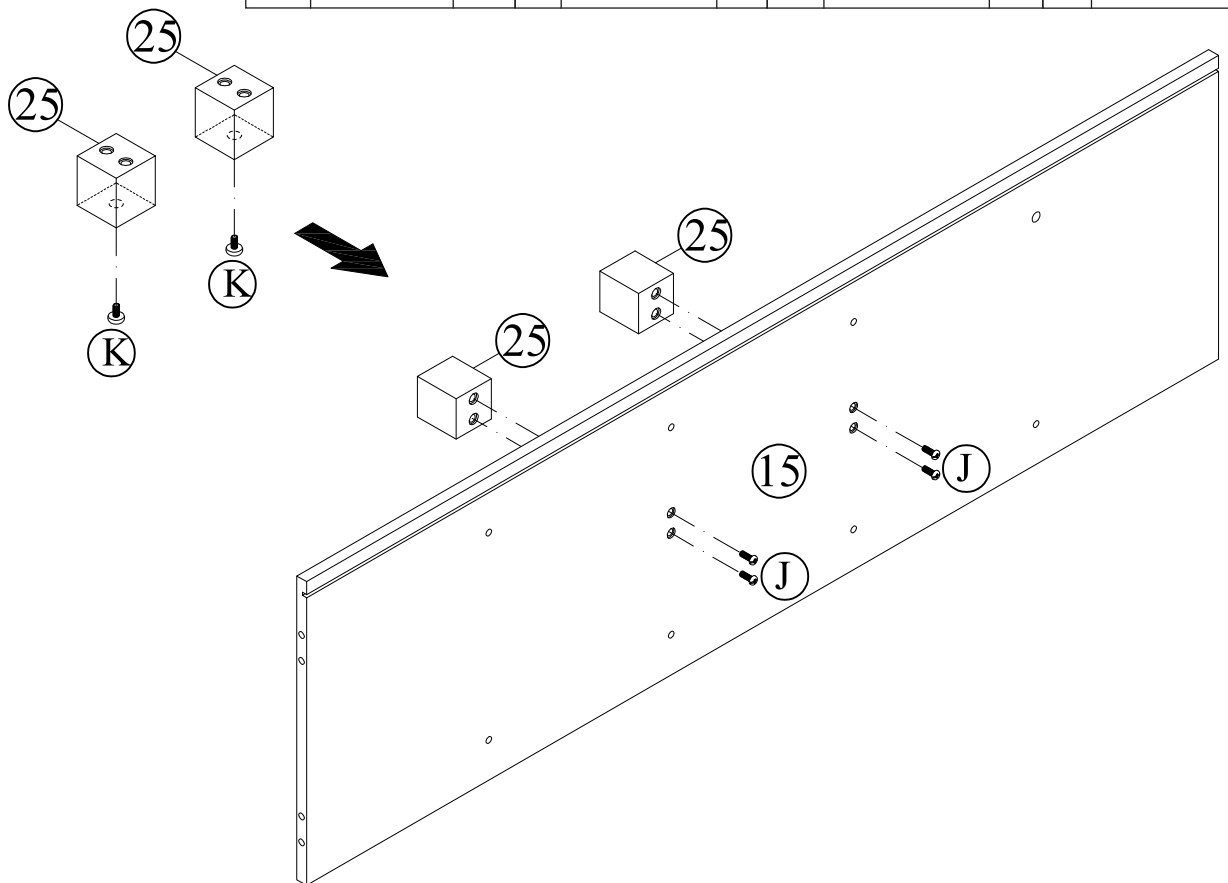

Step/Étape 21

18

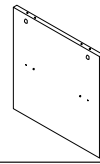

2 A



4

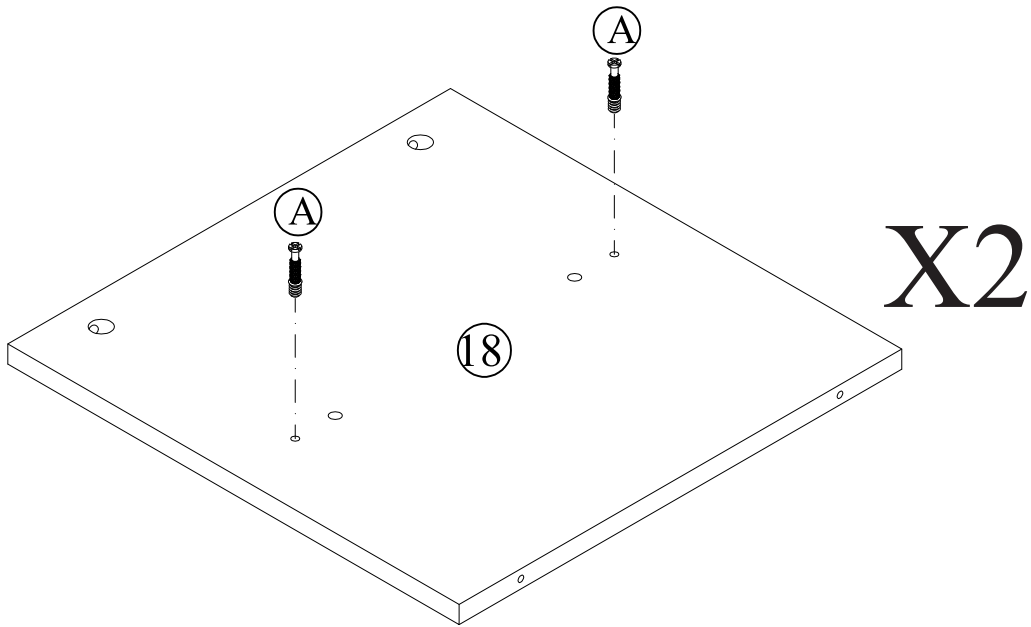

Step/Étape 22

19

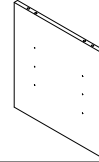

2 N

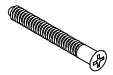

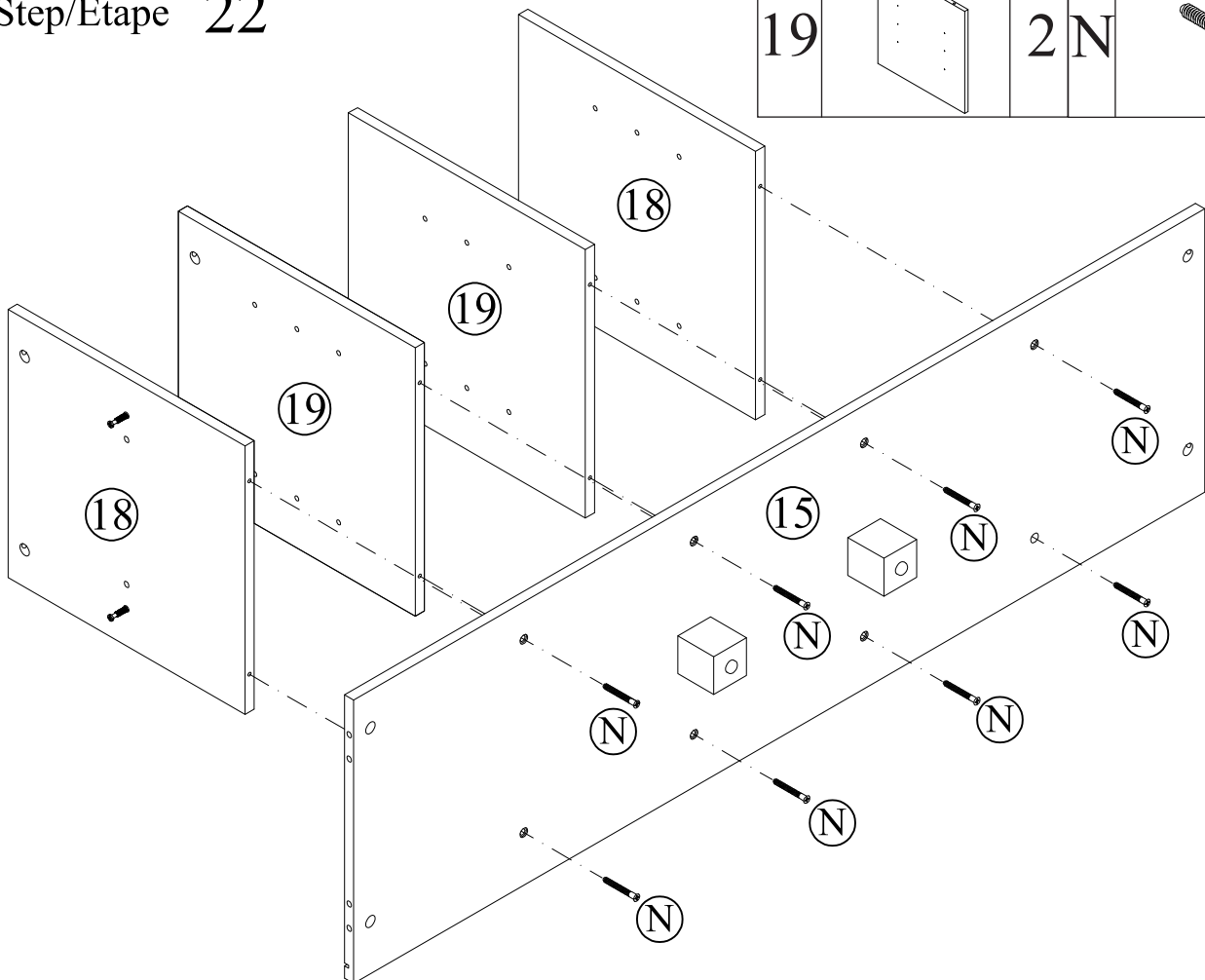

8

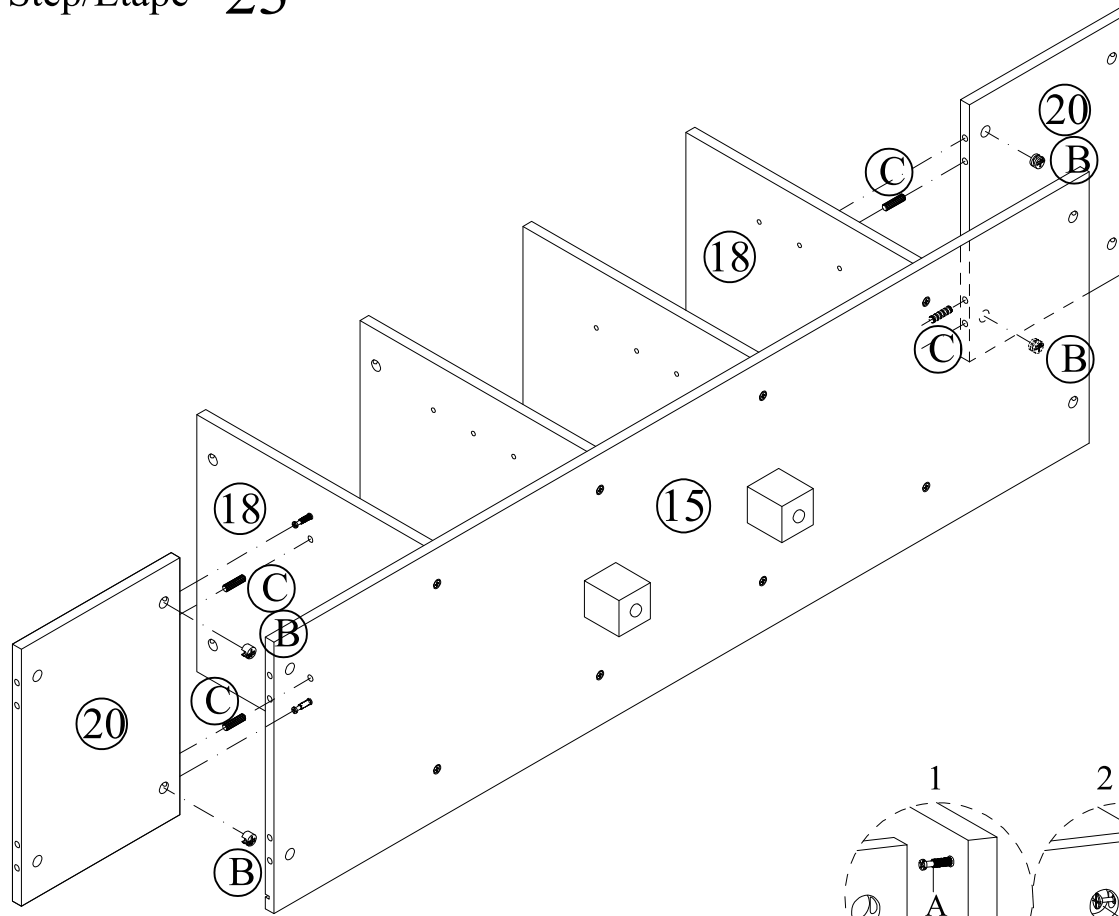

Step/Étape 23

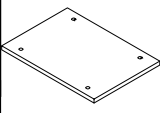

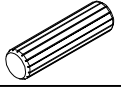

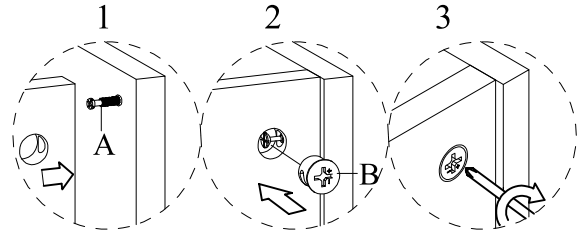
20		2
B		4
C		4



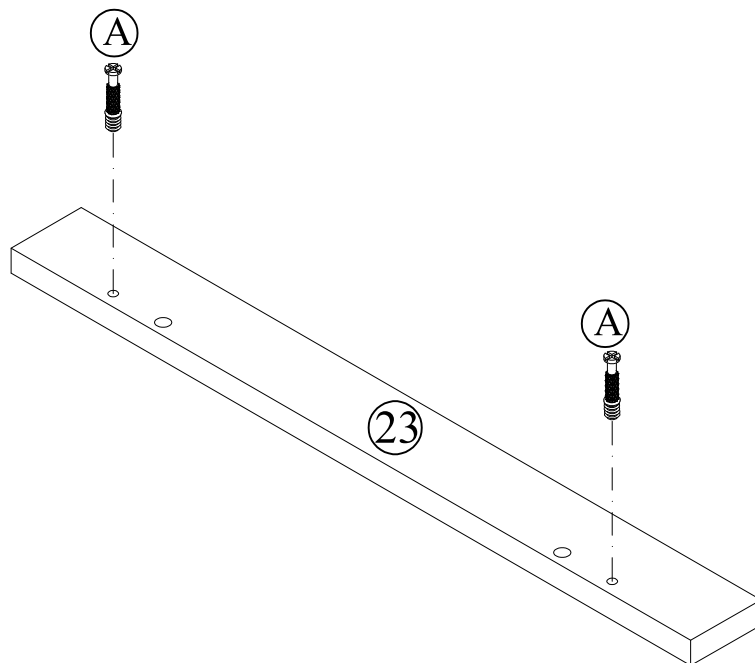

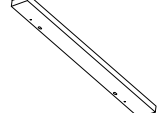
Step/Étape 24



23		2
A		4

X2

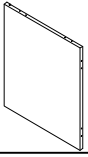
Step/Étape 25

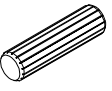
16		1
B		2
C		2

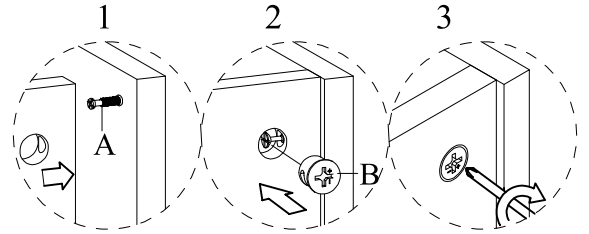
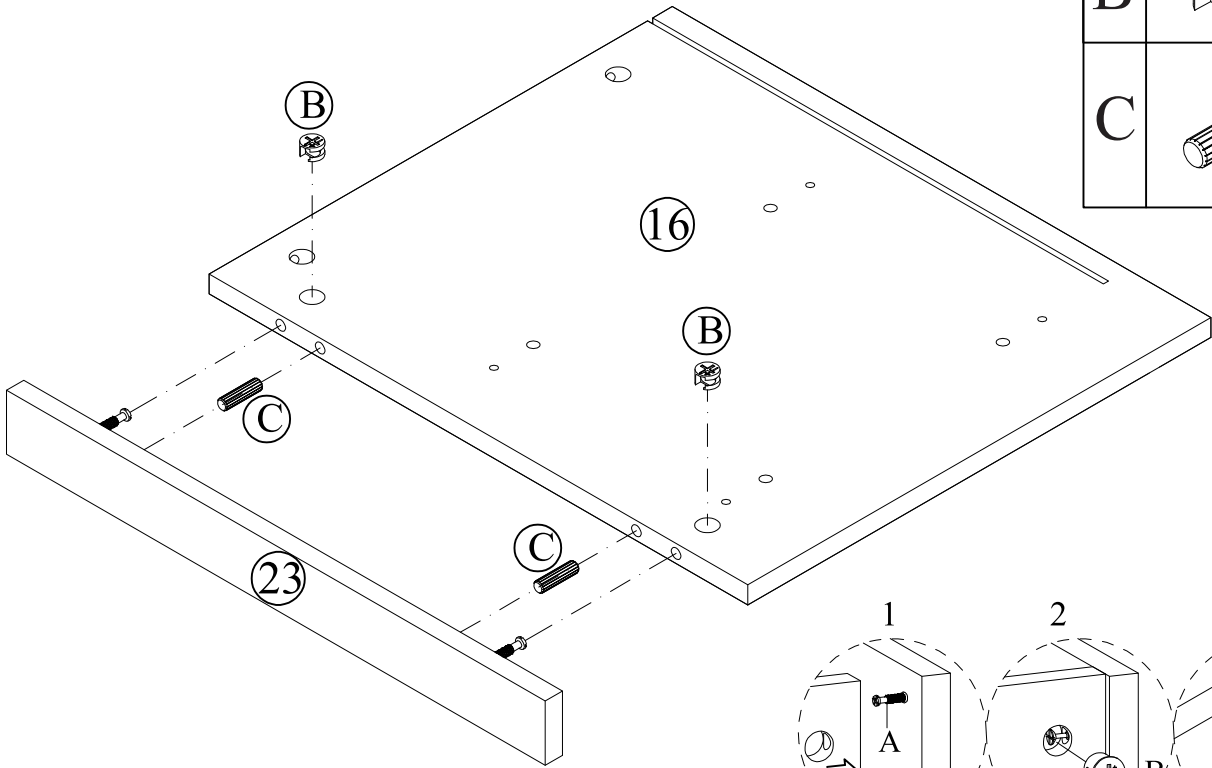

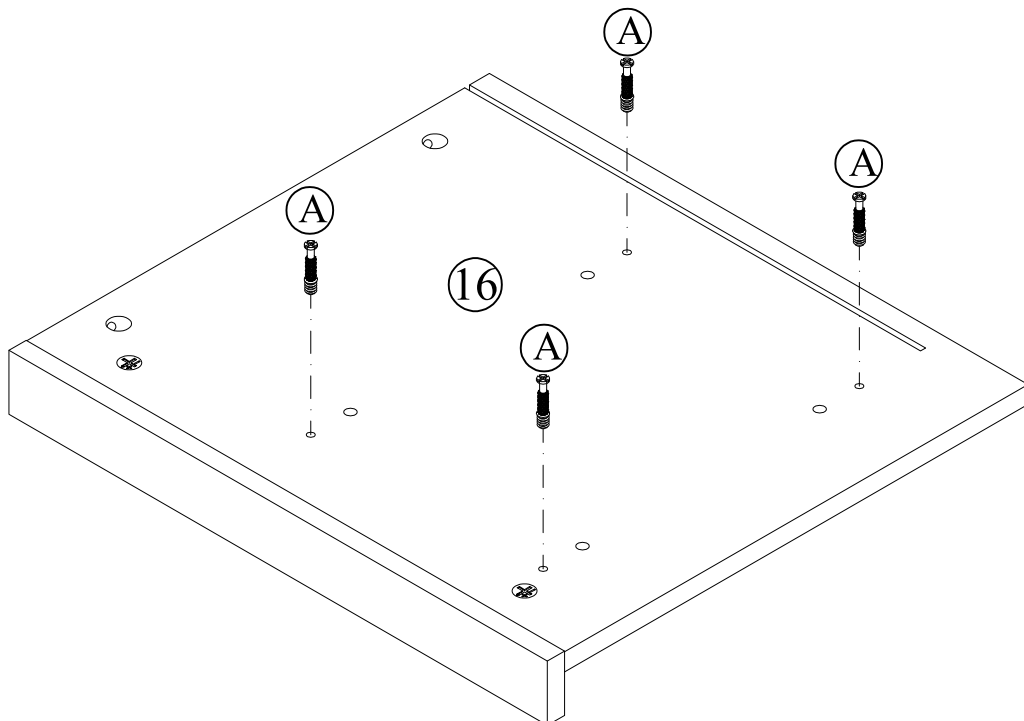

Step/Étape 26

A		4
---	---------------------------------------------------------------------------------------	---

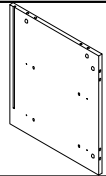

Step/Étape 27

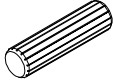
17		1
B		2
C		2

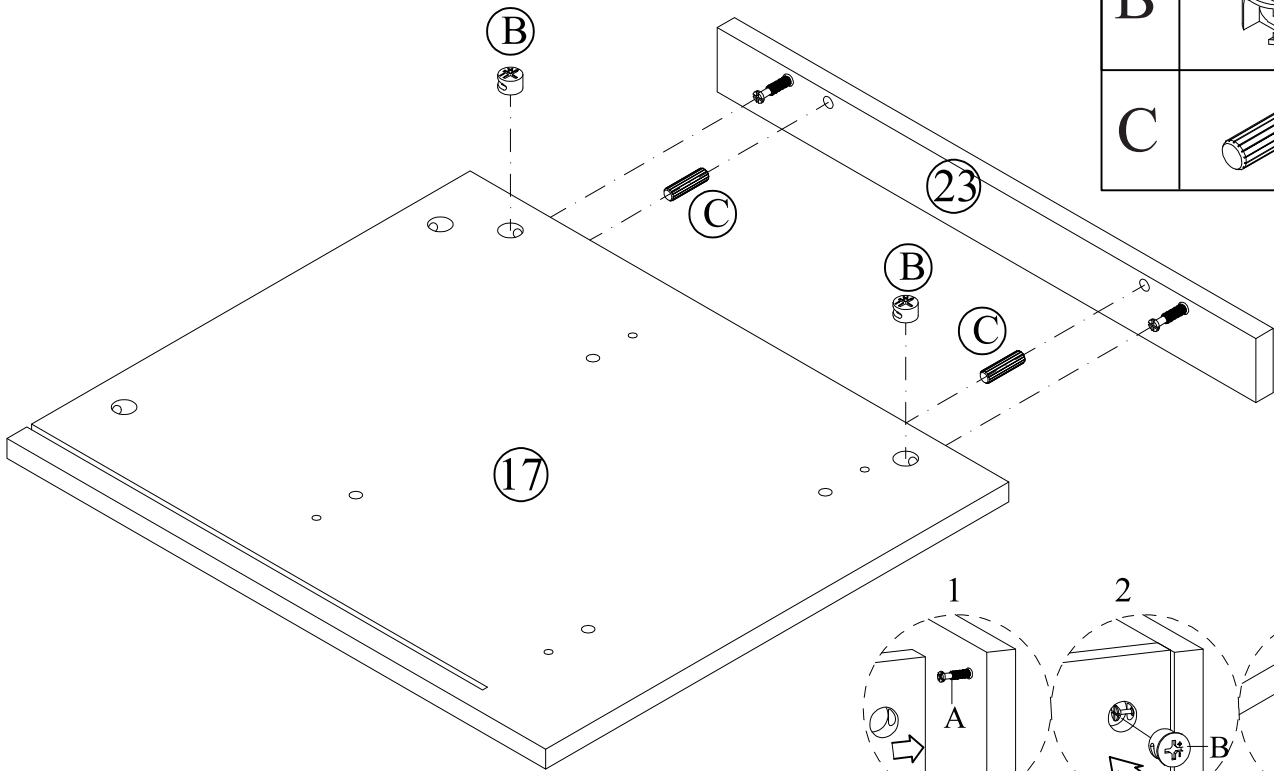

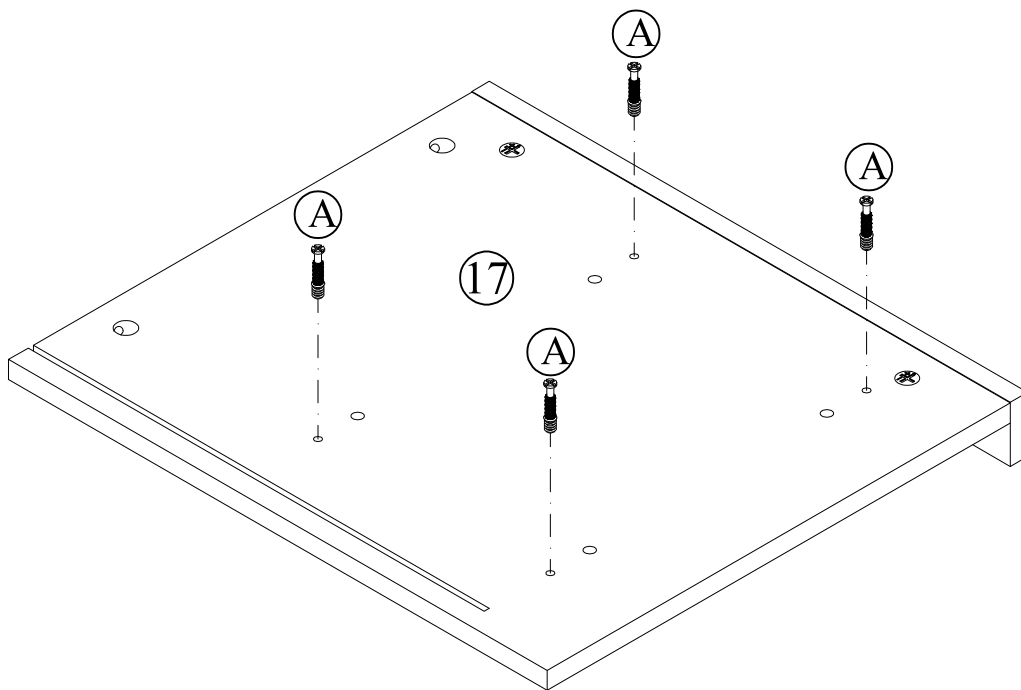

Step/Étape 28

A		4
---	---------------------------------------------------------------------------------------	---



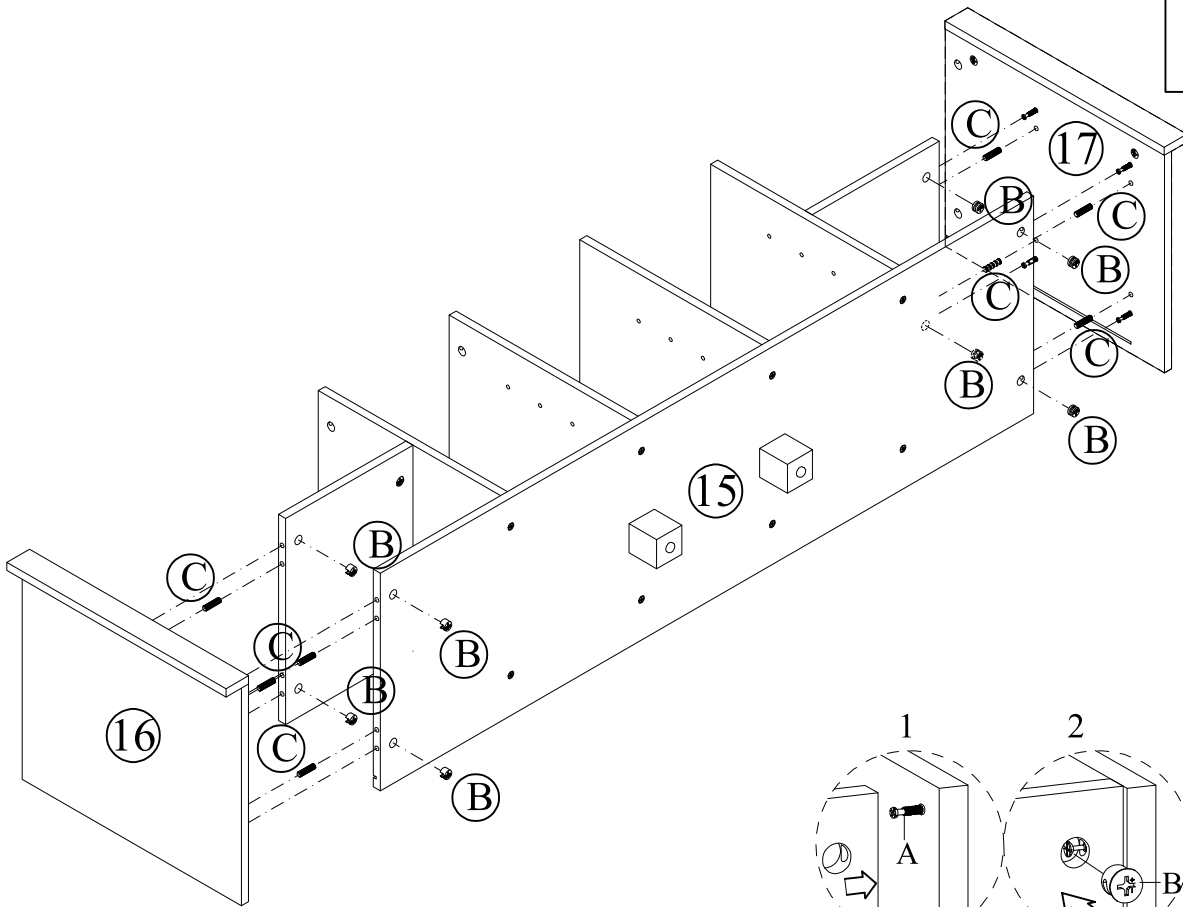

Step/Étape 29

B		8
C		8

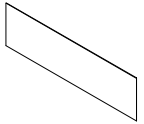

Step/Étape 30

24		1
C		12

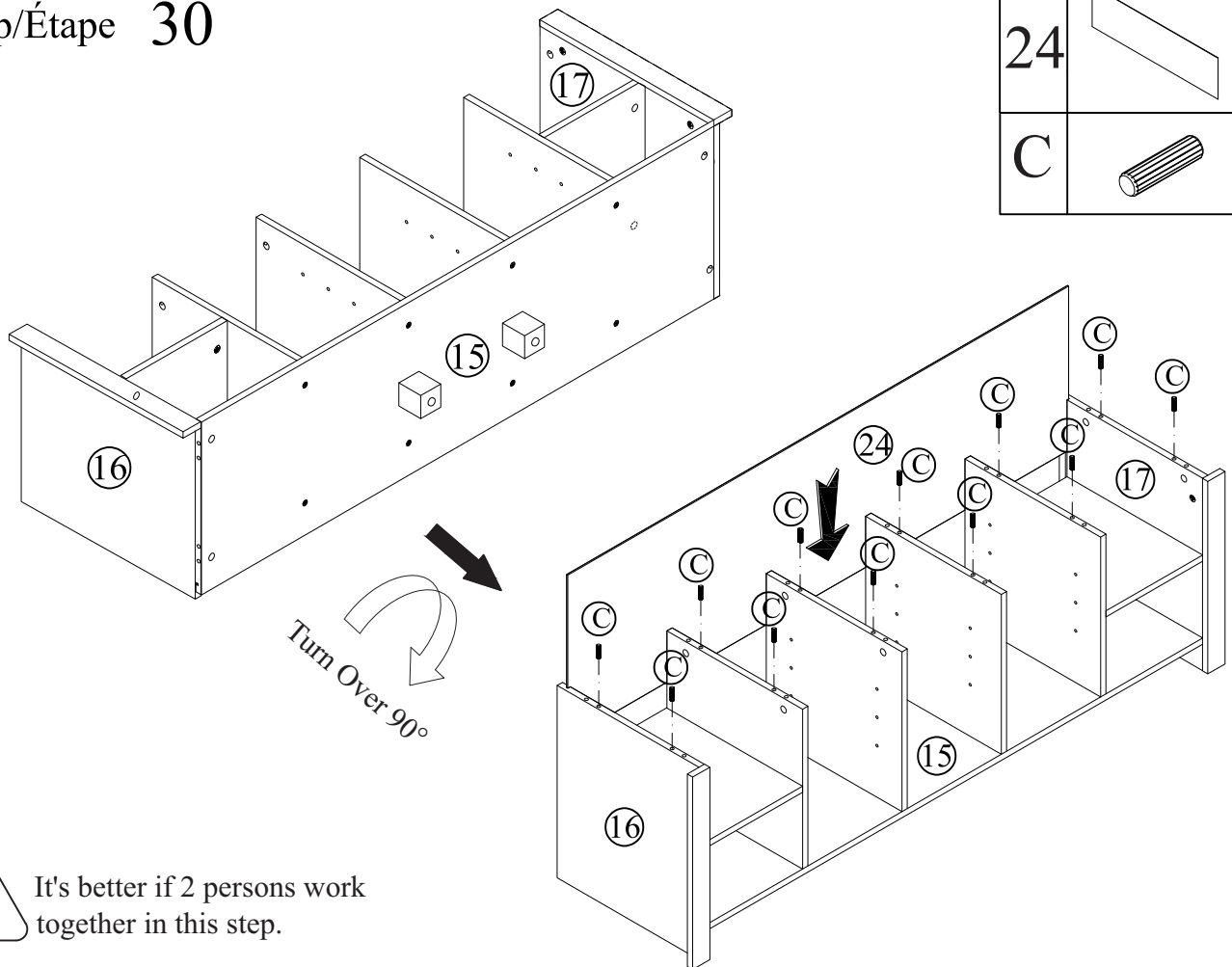

Turn Over 90°



It's better if 2 persons work together in this step.

Step/Étape 31

B



12

Two people helped to stand up numbers 8 and 9 upright to prevent them from falling apart.



It's better if 2 persons work together in this step.

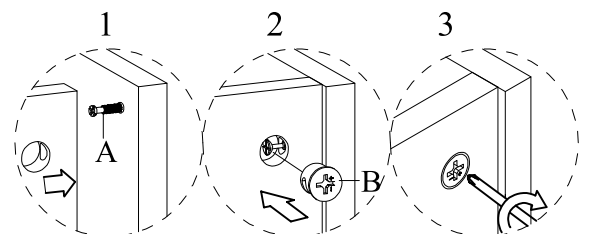
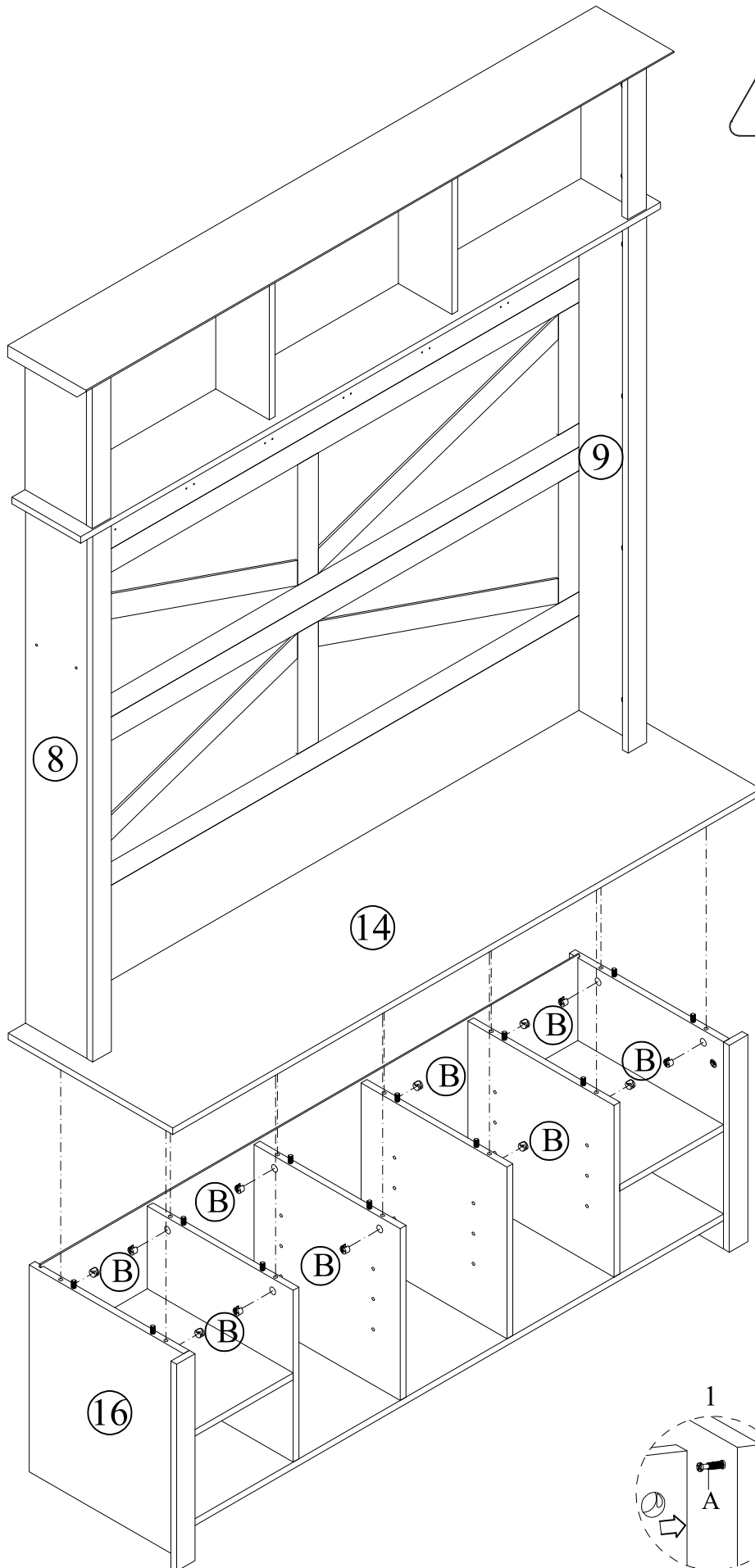

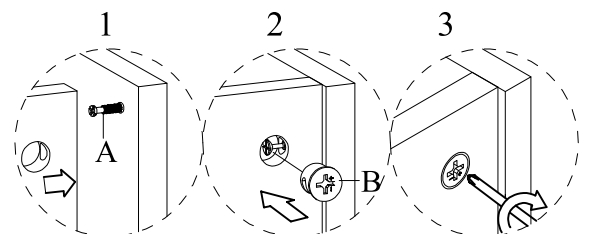
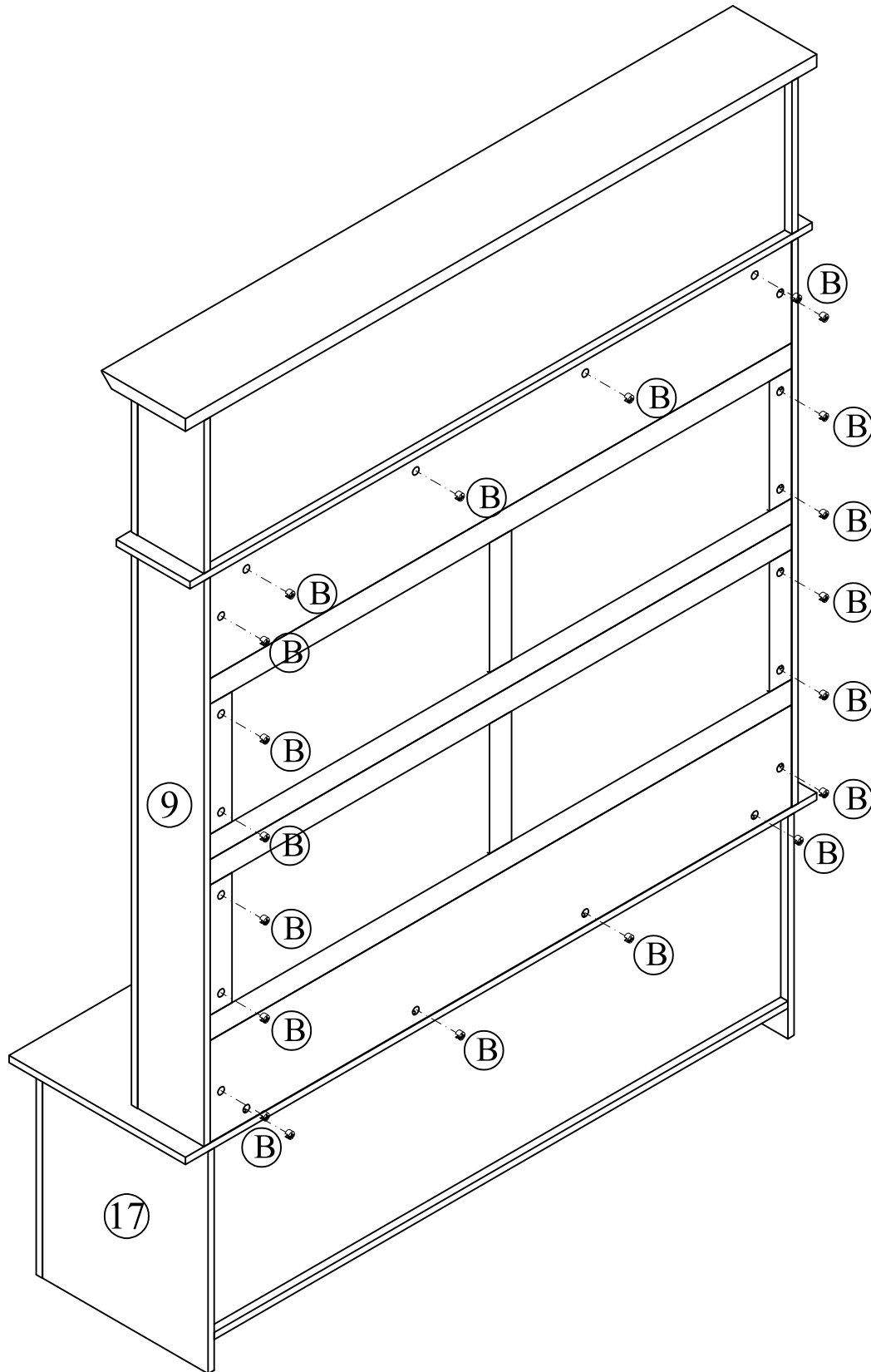

Step/Étape 33

H

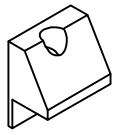

24

I



24

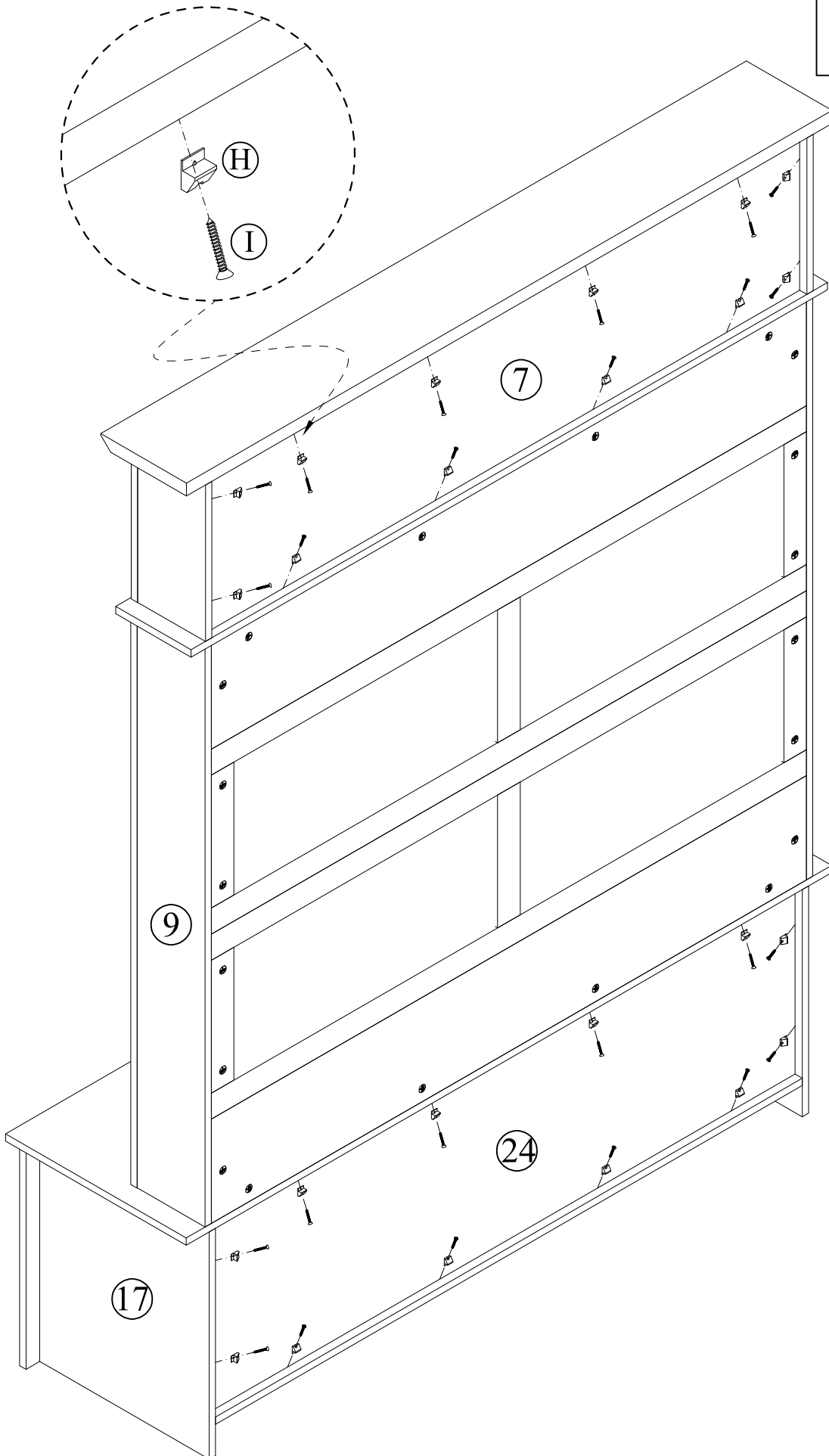

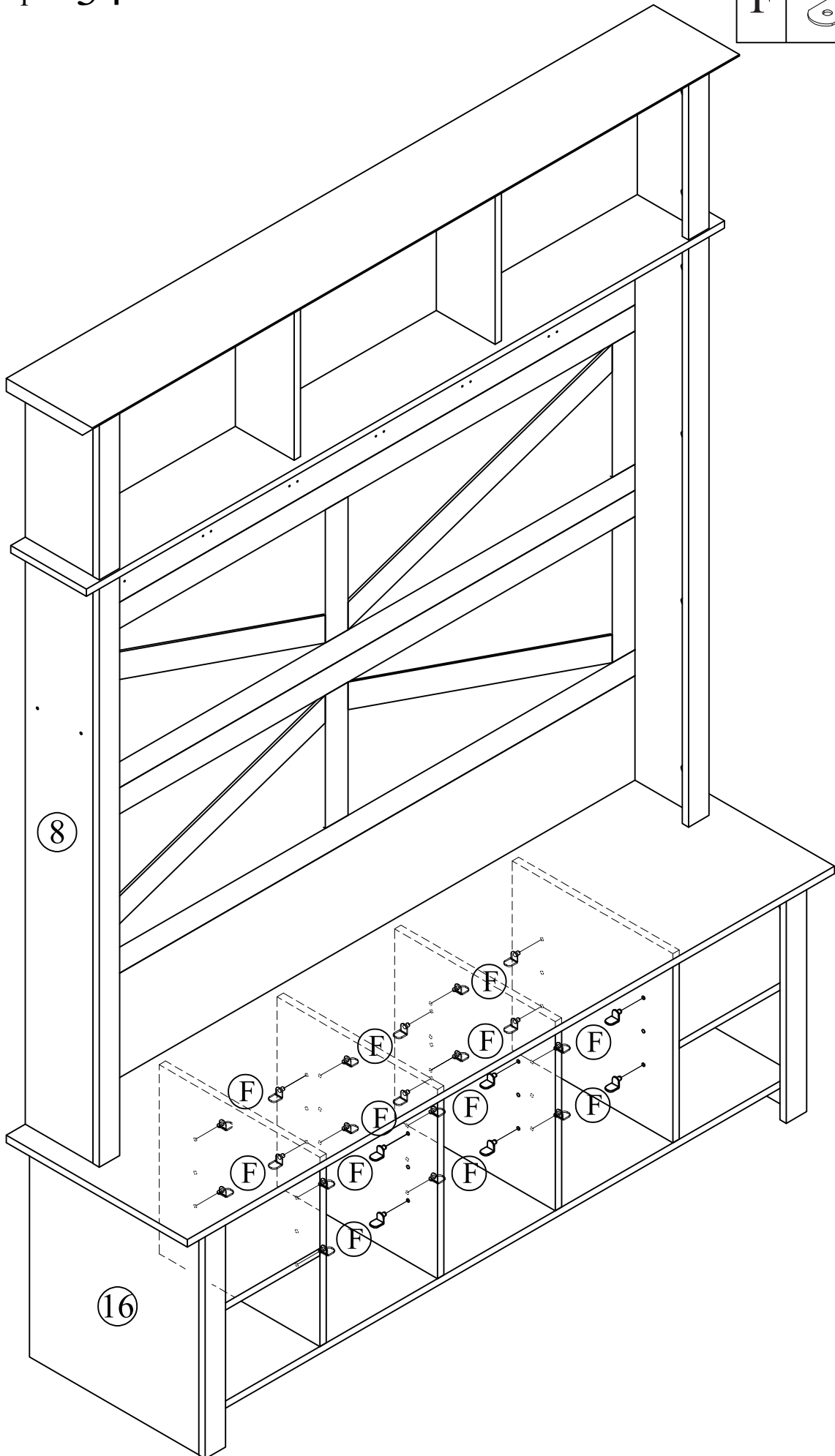



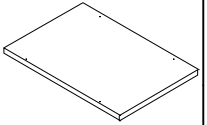
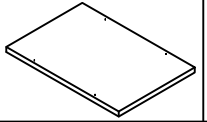

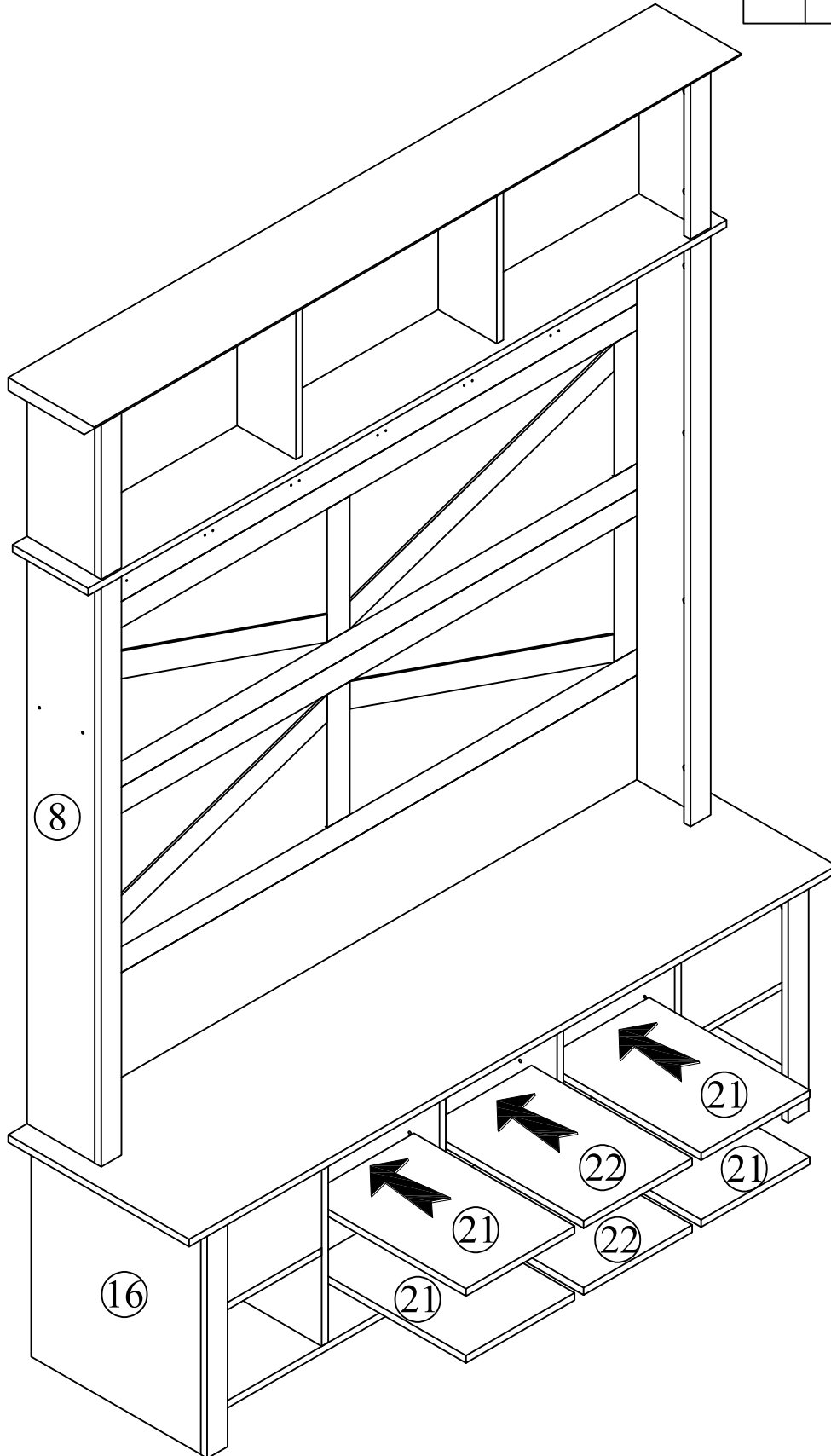
Step/Étape 35

21		4
22		2

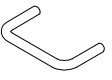

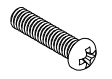
Step/Étape 38

D		6	L		1
E		12	M		2
			P		72

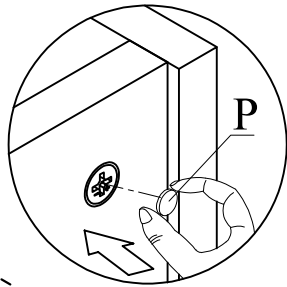

(P) can be utilized as a shielding component for the exposed holes, enhancing the overall aesthetic of the product.

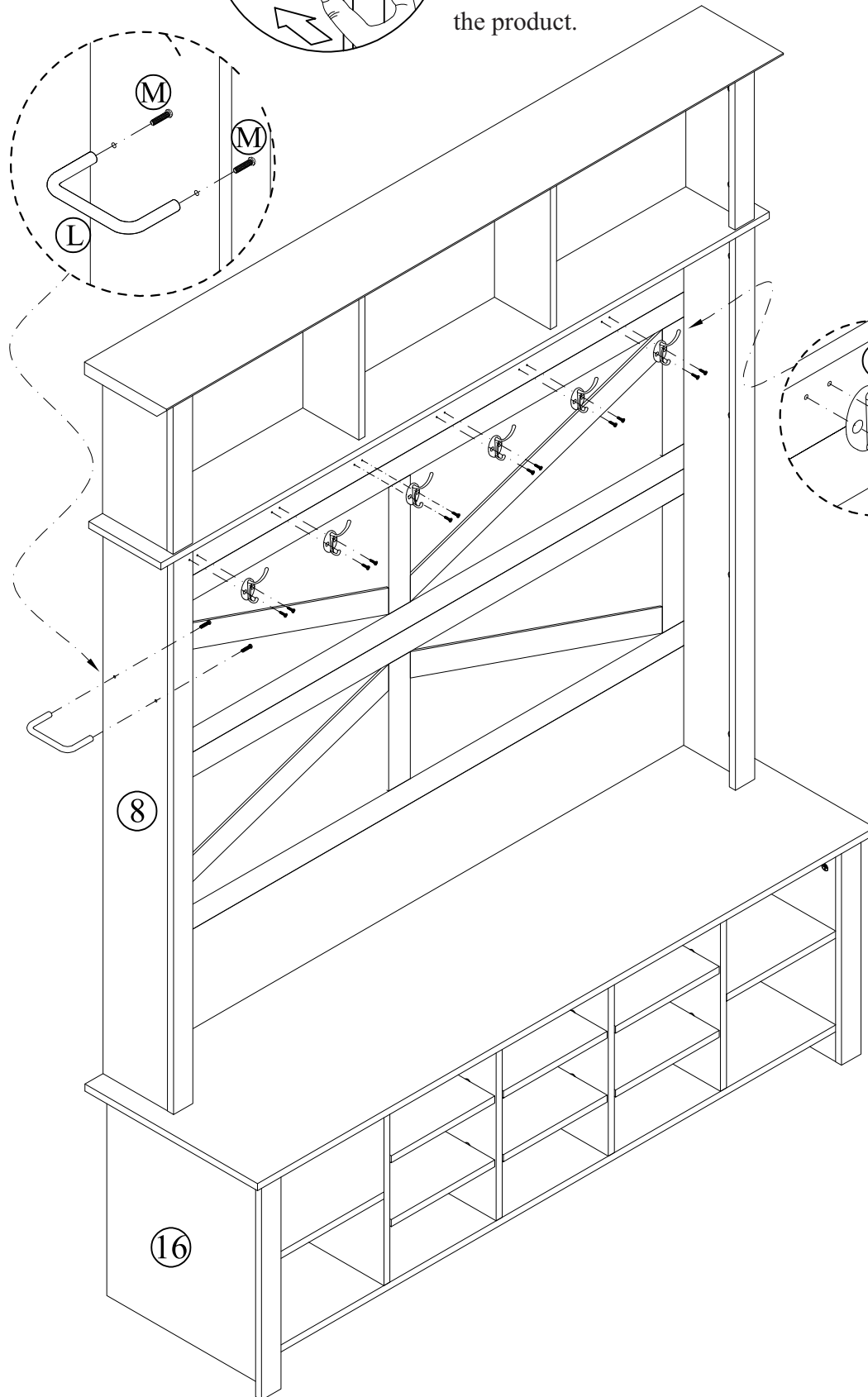
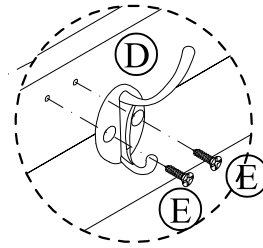
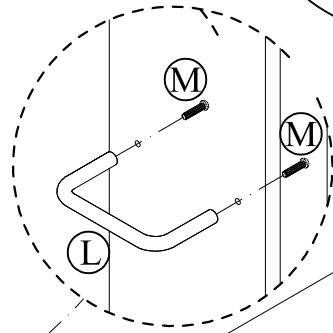

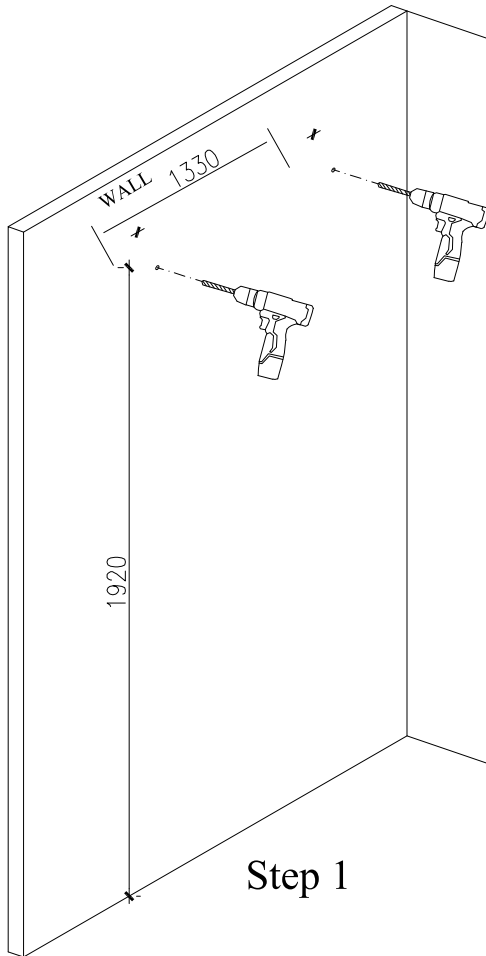
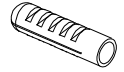

This step involves drilling two mounting holes into the wall at precise positions, to prepare for securing a fixture or structural component.

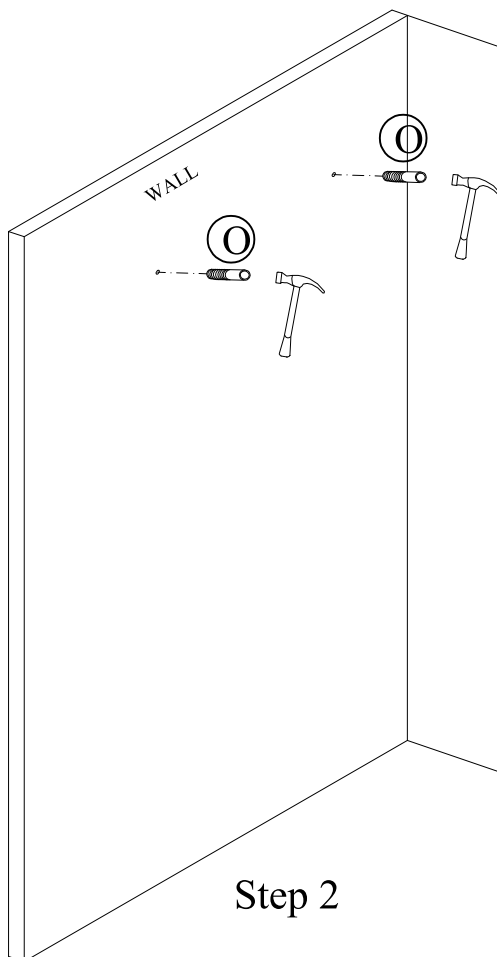

Step 1



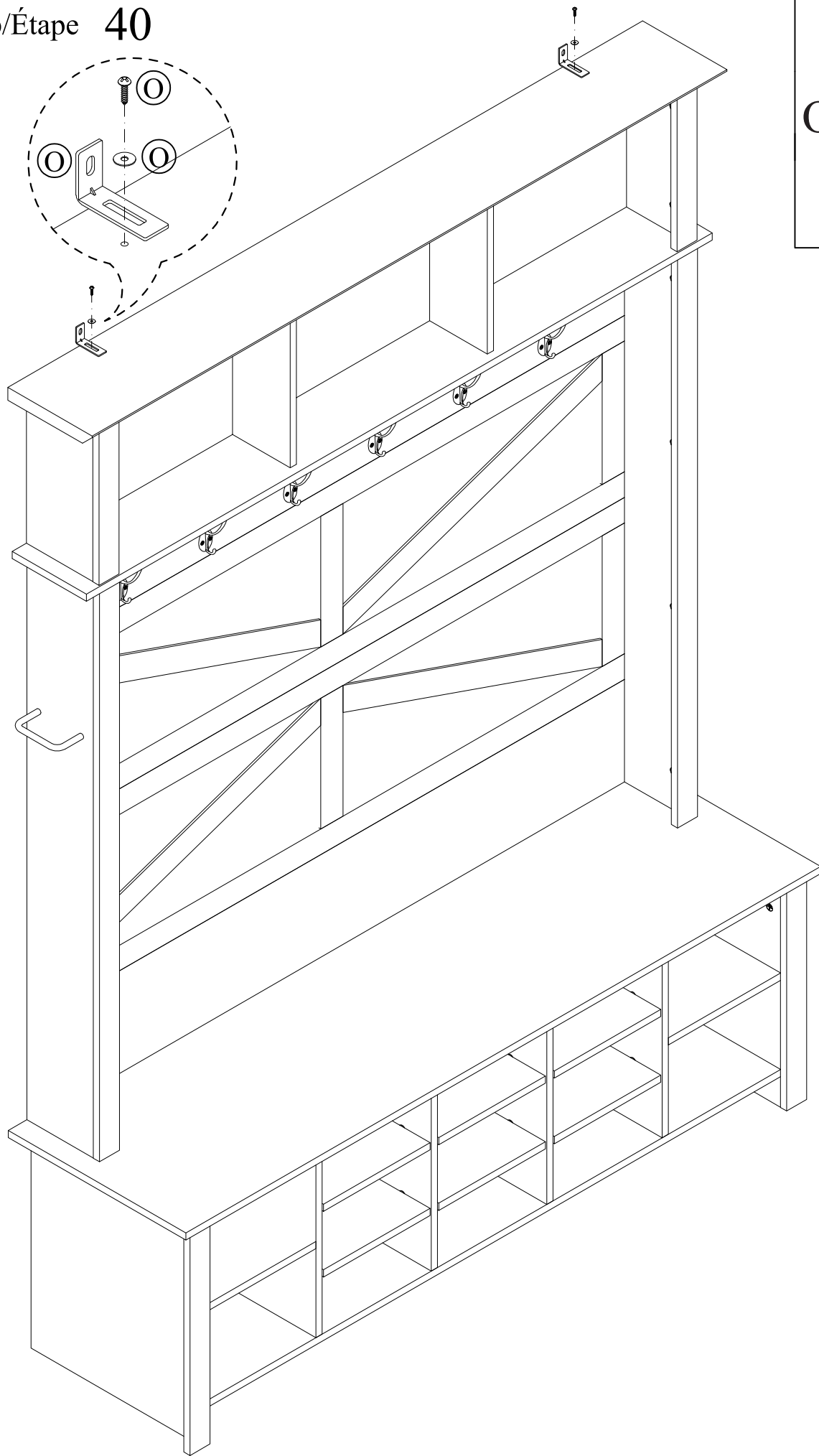

Step 2

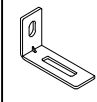
Step/Étape 40

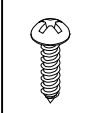

0		2
0		
		

Step/Étape 41

O		2
Q		2

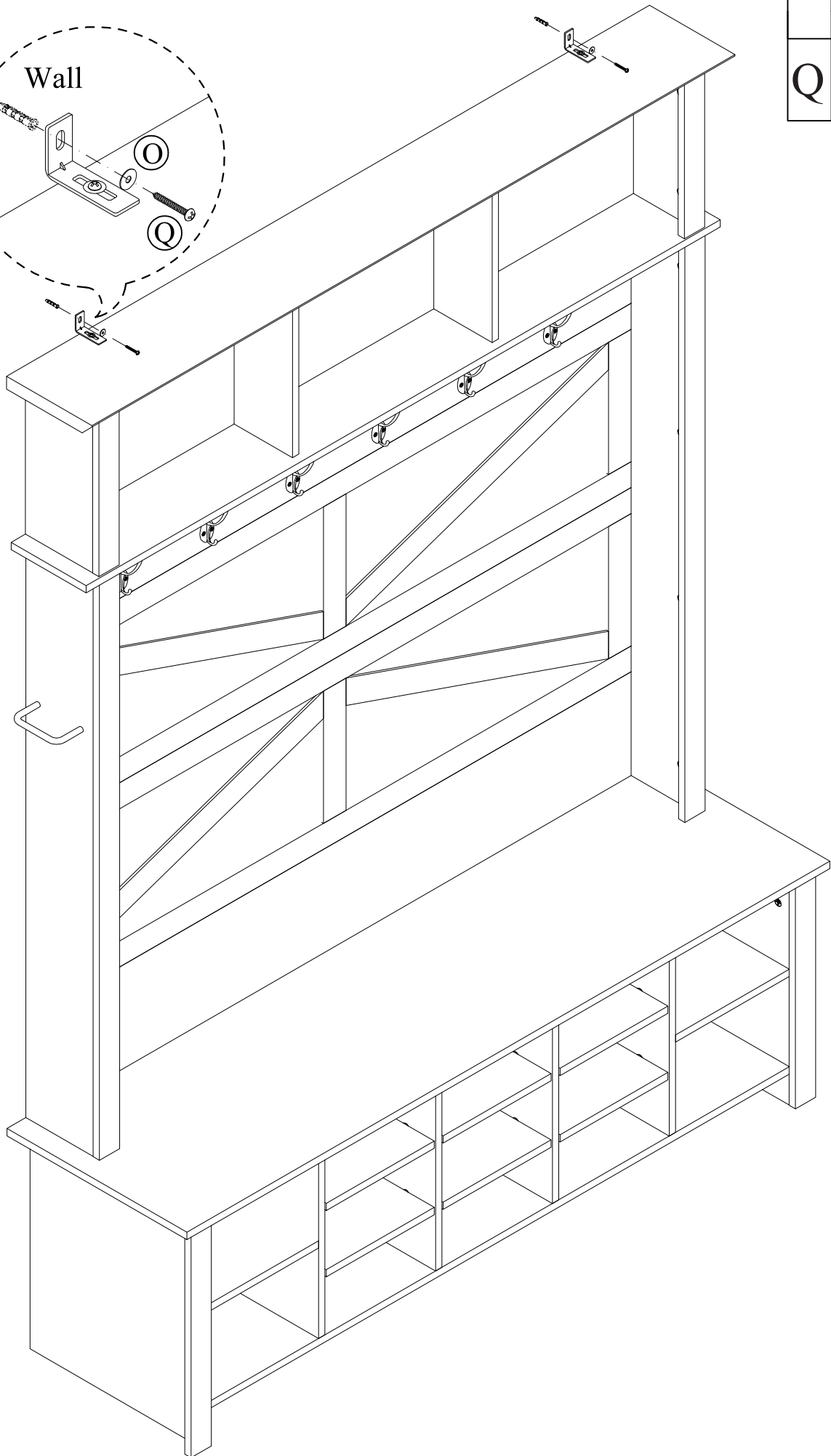
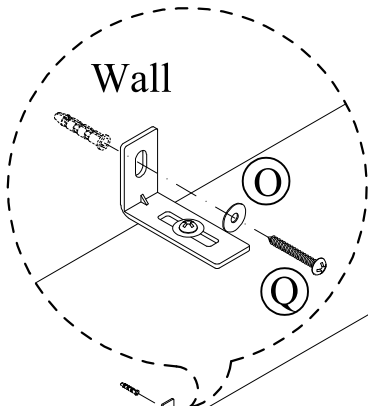

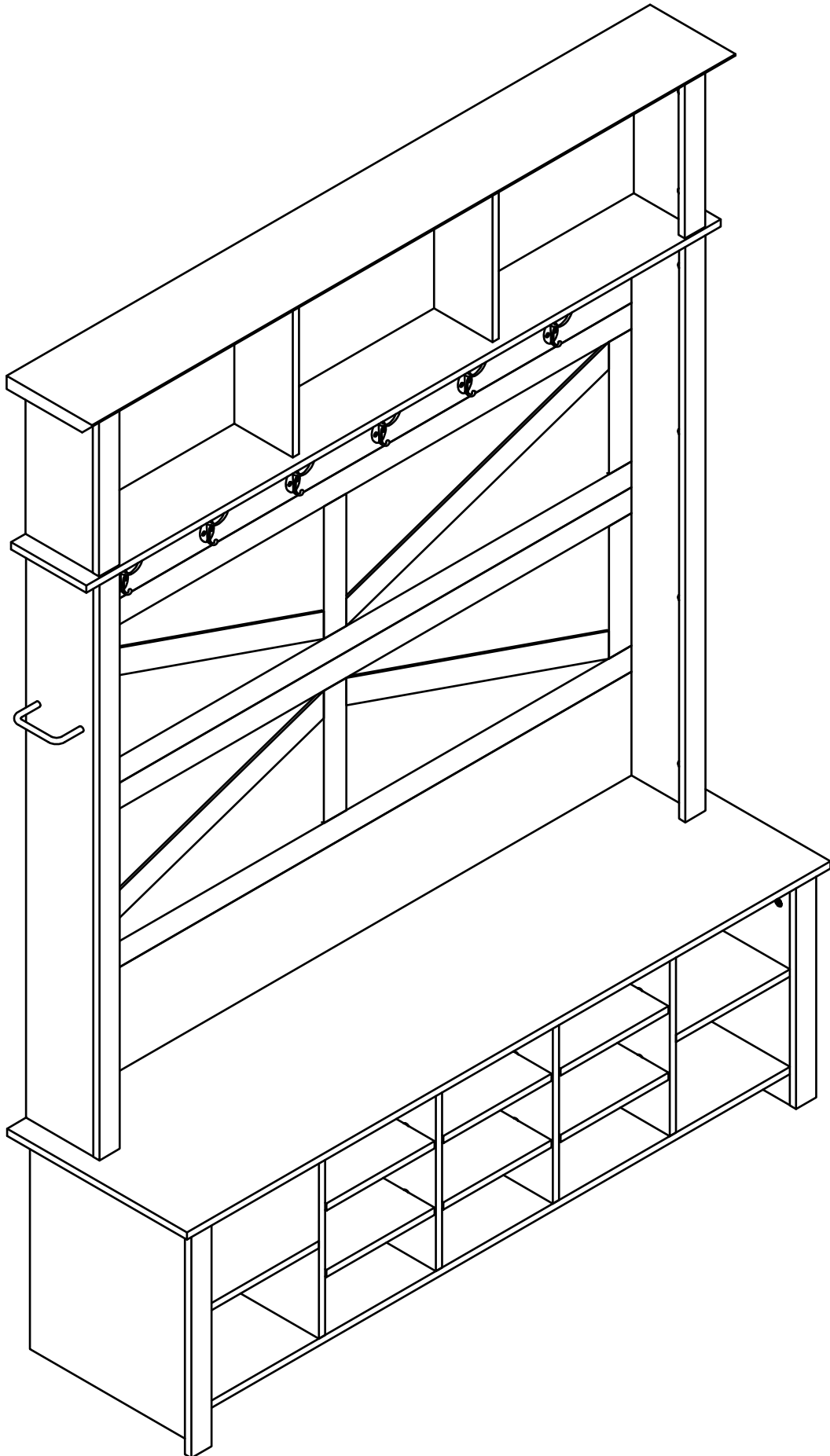

Finish/Finir