

2-POINT HANGING HAMMOCK CHAIR WITH A-STAND





Read all assembly and care instructions carefully before using this product. Save these instructions for future reference.

Select a smooth, level surface to place the hammock chair stand.
Assemble components on a soft, clean surface to avoid scratching/damaging the finish.

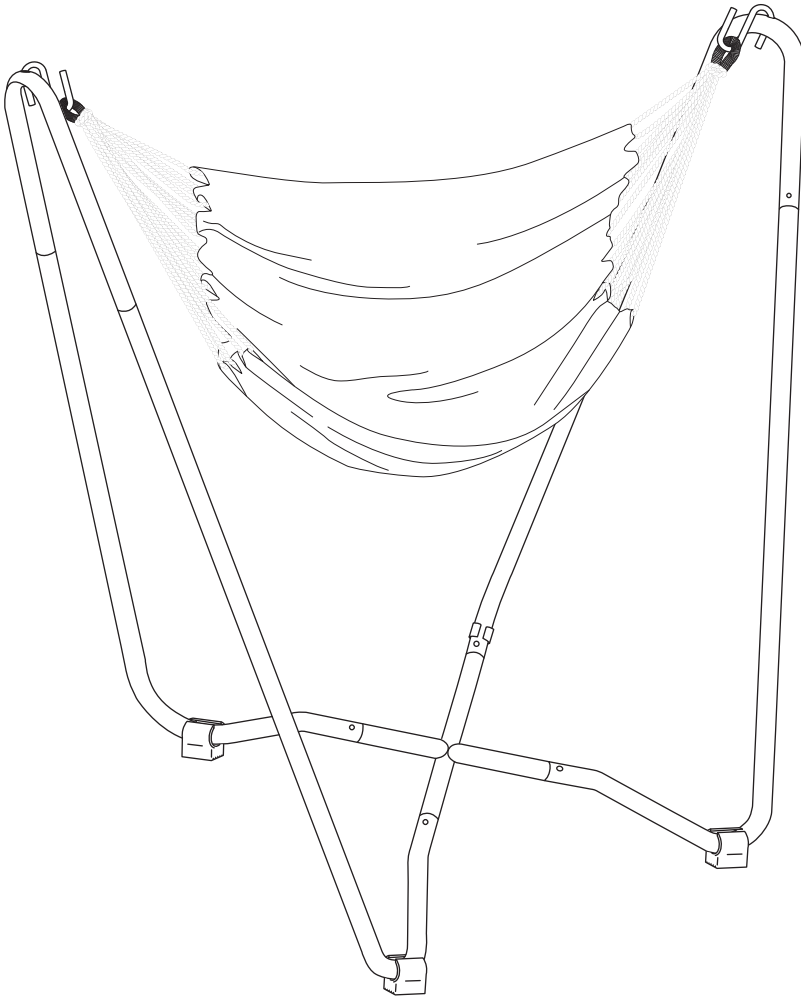

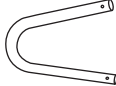
Inspect packaging to ensure all parts are accounted for before disposing of packing materials.

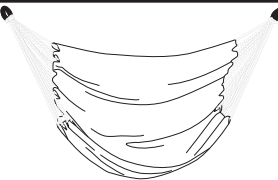

No.	PARTS		QTY.
A		Top Support	2
B		X-Support	1
C		Leg	4
D		S-Hook	2
E		Foot	4
F		2-Point Hammock Chair	1



2-PERSON
ASSEMBLY
RECOMMENDED

⚠ CAUTION ⚠

This hanging hammock chair with stand is not designed for use as a swing. Bouncing, swinging, and any other significant movement may result in serious injury.

This product must be used on a level, stable surface. Make sure all snap buttons are properly engaged before each use.

Weight Limit: 330 lbs.

⚠ WARNING:

Manufacturer and seller expressly disclaim any and all liability from personal injury, property damage or loss, whether direct or indirect, or incidental, resulting from the incorrect attachment, improper use, inadequate maintenance, or neglect of this product.

ASSEMBLY

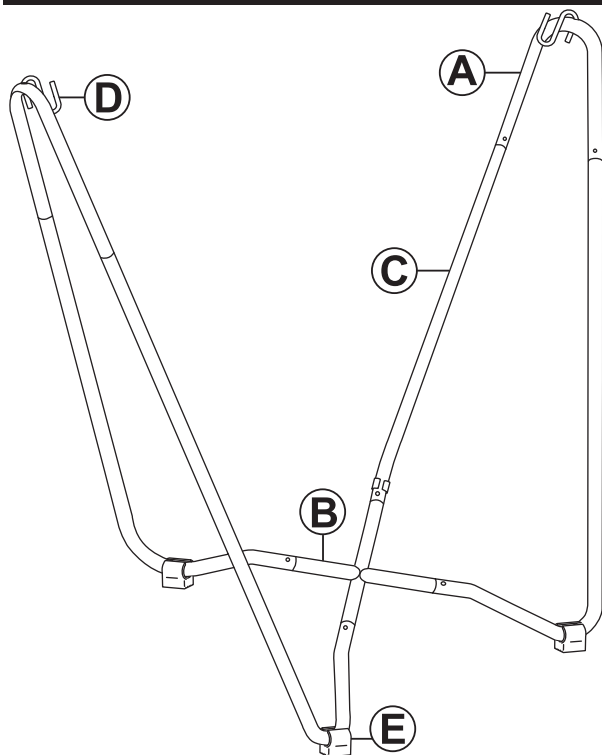

1. Carefully snap or slide Foot (E) onto the curved edge of Leg (C) as shown.
2. Align the spring button on the straight side of Leg (C) with the hole in Top Frame (A). Press the button and slide the leg onto the support until the button snaps through the hole. Repeat on the opposite side of the top support.
3. Repeat Step 2 for the other side of the stand.
4. Align the holes on the curved sides of Legs (C) with the spring buttons on X-Support (B). Press the button and slide the leg onto the support until the button snaps through the hole. Repeat until all legs are secured.
5. Place 1 S-Hook (D) into the top of each Top Support (A).
6. Ensuring the ropes are not twisted, hand Hammock Chair (F) on the S-hooks.

USE & CARE

- **SAFE USE:** Swinging, bouncing, jumping and other excessive movement while using this product could result in serious injury.
- **CHILDREN:** Supervise children at all times. Do not allow children to play or sleep in hammock chairs.
- **STORAGE:** Store indoors when not in use. A cool, dry location is recommended to prevent damage from exposure to moisture and sunlight.
- **INSPECT:** Ensure the stand is assembled correctly and all spring buttons are intact before each use. Do not use the hammock chair if the ropes, fabric, or stand show signs of weakness.
- **SCRATCHES:** The powder-coating is tough and durable, but even under normal use, some scratching is inevitable. Scratches can be repaired with rust-resistant paint. **NOTE:** painting the stand will void the product warranty.

CLEANING



SPOT CLEAN/HAND-WASH ONLY



DO NOT USE BLEACH OR FABRIC SOFTENERS



LAY FLAT TO DRY

HAMMOCK: Spot clean with a damp cloth.

For more stubborn stains, hand-wash in a bathtub or kiddie pool using mild soap and a soft-bristled scrub brush. Soaking may be required for heavily soiled fabric or ropes. Keep the wooden spreader bars, metal components out of the water as much as possible.

Thoroughly rinse all soap residue. Air-dry on a flat surface to prevent the ropes from stretching. The ropes may shrink slightly while drying but will stretch back out with use.

STAND: Use a soft, damp cloth to wipe down the stand.

TROUBLESHOOTING

- If the stand seems unstable, make sure it is on a level surface, and the feet are correctly distributed.
- If a spring button does not engage during assembly, it may be misaligned or stuck. Check to make sure the button is properly aligned with the corresponding hole. If the button is stuck, use a thin, small tool to help release the button from the tube in which it is installed.

Any modification to the product or failure to follow recommended care will void the product warranty.