











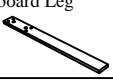



ASSEMBLY INSTRUCTIONS

FULL BED (4+4)

(Box 1)
BOX OF HEADBOARD & FOOTBOARD

No	ITEM	Qty
A	Headboard 	1 pc
B	Footboard 	1 pc
C	Headboard Leg 	2 pcs
D	Bed Slats 	4 pcs
E	Bed Slats Support 	4 pcs
F	Side Rail(A)-Left 	2 pcs
G	Side Rail(B)-Right 	2 pcs
H	Bed Side Rail Leg 	2 pcs

(Box 1)
HARDWARE LIST

No	ITEM	Qty
1	JCBC M6 x 35mm 	12 pcs
2	SPRING WASHER 1/4" Rbw 	12 pcs
3	Flat Washer 1/4"ID x 13mmOD Blk 	12 pcs
4	ALLEN KEY m4x65mm Blk 	1 pc
5	ALLEN KEY m5x65mm Blk 	1 pc
6	Flat Head Chipboard Screw m4x32mm Rbw 	16 pcs

STEP 1.1 : Attach Head Board Leg (C) to Head Board (A) as shown using JCBC BOLT(1)with Spring Washer (2), Flat washer (3) and securing with ALLEN KEY (4) .

STEP 1.2 : Fix the other holes with Csk Screw (6) as shown.

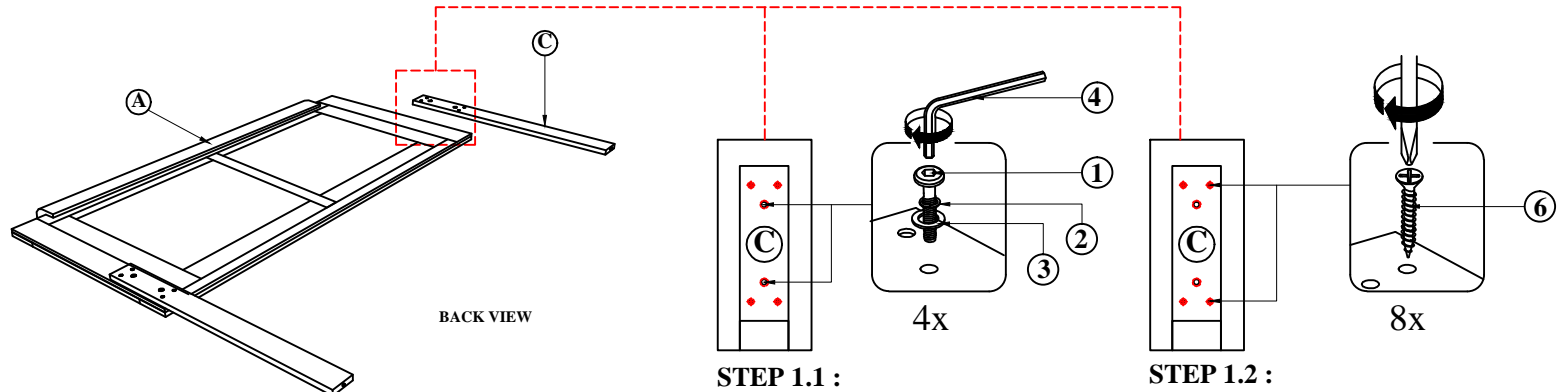

STEP 2.1 : Attach Side Rail (F) & (G) to the Bed Side Rail Leg (H) as shown using

JCBC BOLT(1)with Spring Washer (2), Flat washer (3) and securing with ALLEN KEY (4) by outside side rail (F) & (G) .

STEP 2.2 : Hook SET-UP SIDE RAIL TO HEAD BOARD (A) closely and push down to fit. repeat step 2 with other end of rail to hook onto FOOTBOARD (B).

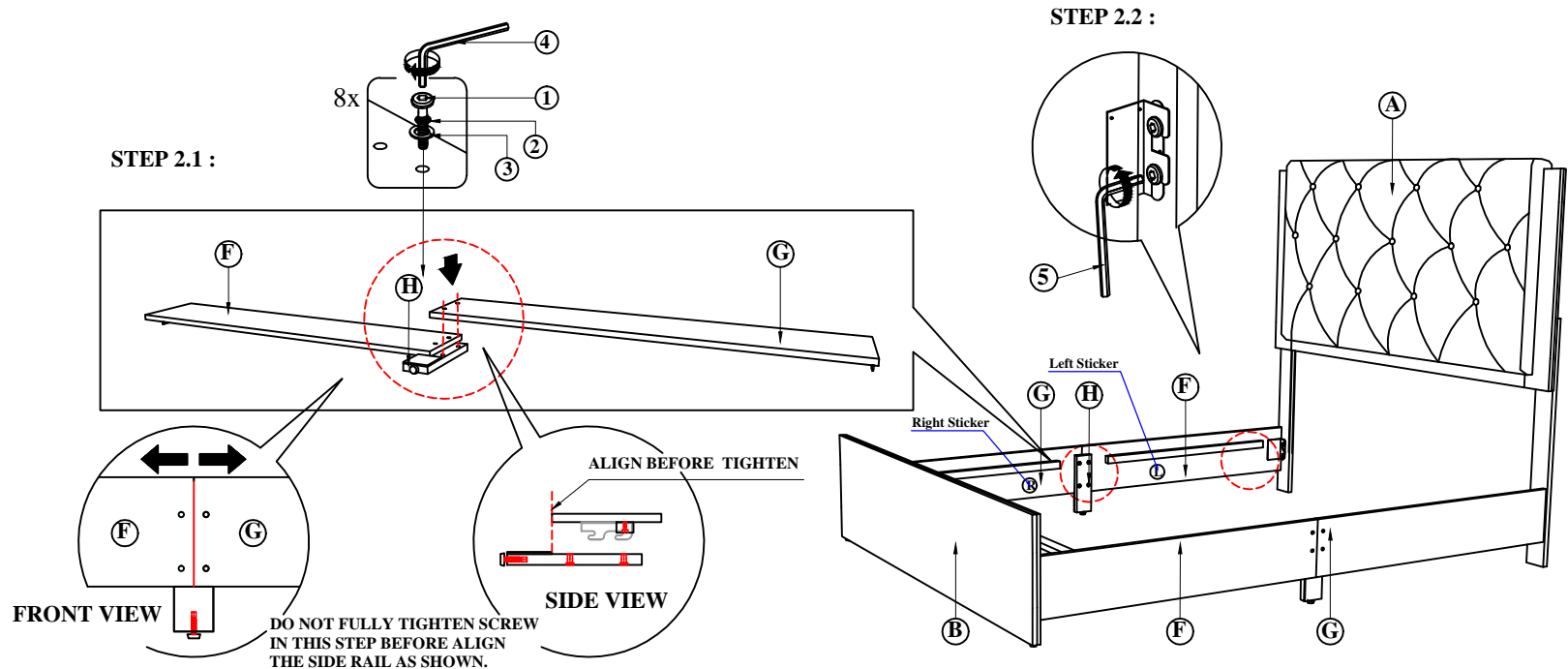

NOTE : MUST TIGHTEN SCREWS PERIODCALLY WITH USE SCREW WILL BECOME LOOSE CHECK TIGHTNESS OF ALL SCREW EVERY 6-8 WEEKS.

PAGE 1 OF 2

ASSEMBLY INSTRUCTIONS

STEP 3 : Tighten the 4 Corner with Allen Key (5). Fix the Bed Slat Support Leg (E), to Bed Slat (D) as shown. Install the bed slat (D) to side rail (F) & (G) and tighten with Csk Screw (6) as per diagram shown. (NOTE: THE SETUP MUST BE DONE AT THE DECIDED LOCATION FOR THE BED TO OBTAIN PERFECT STABILITY)

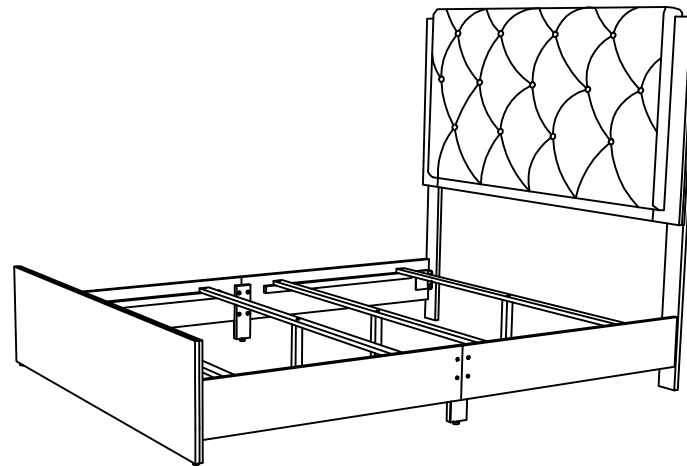
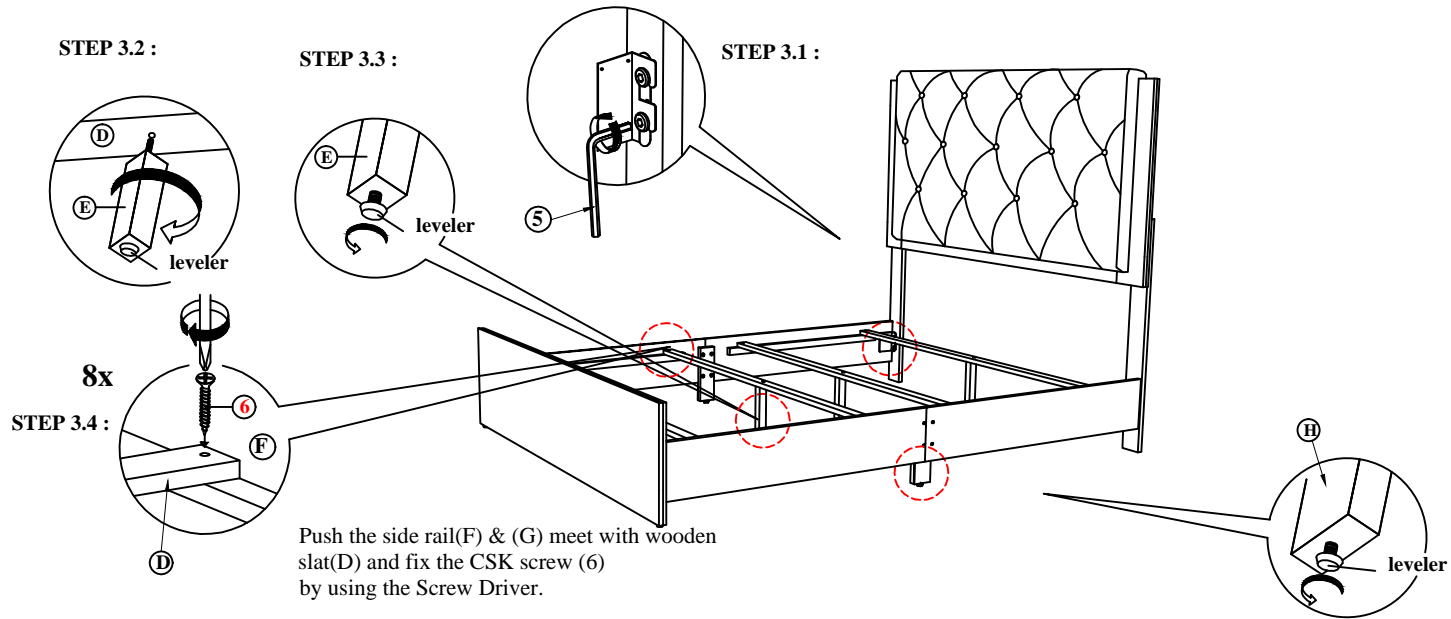

COMPLETE ASSEMBLY

NOTE : MUST TIGHTEN SCREWS PERIODCALLY WITH USE SCREW WILL BECOME LOOSE CHECK TIGHTNESS OF ALL SCREW EVERY 6-8 WEEKS.