

ASSEMBLY INSTRUCTIONS

■ 1-Piece

Deck Box

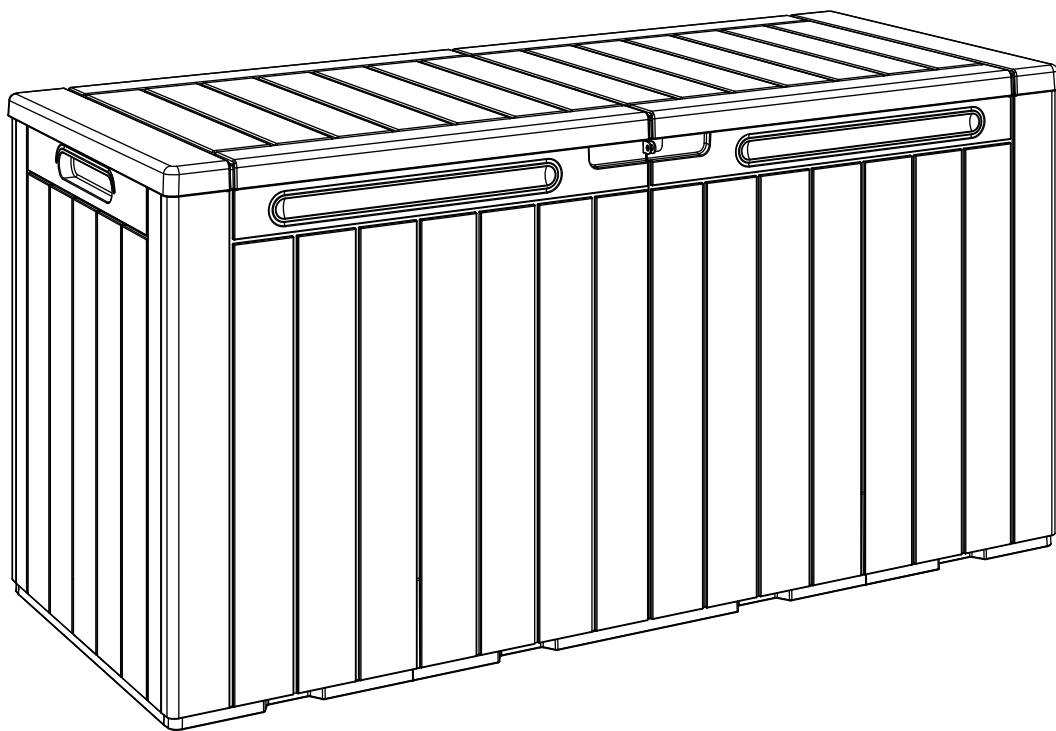





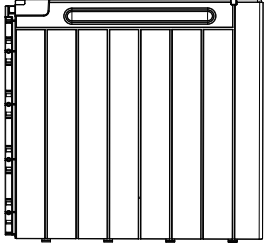
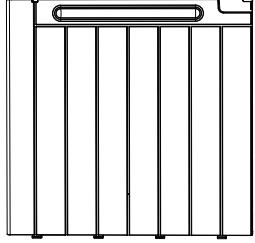
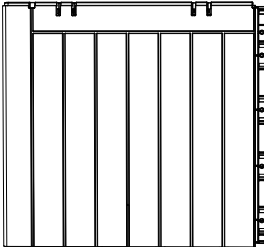
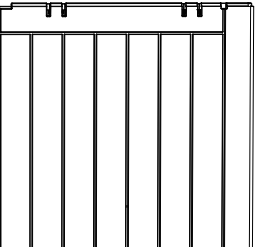
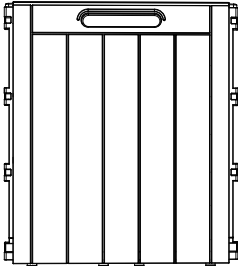
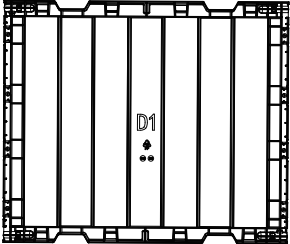
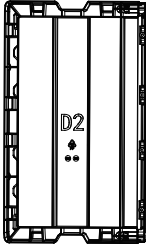
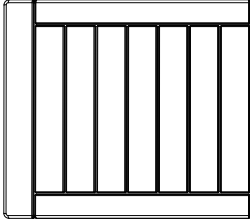
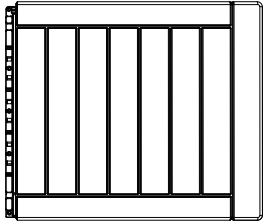

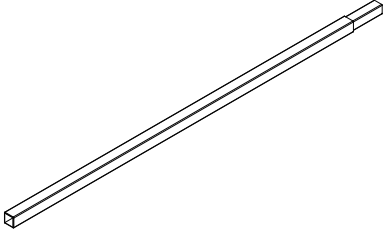
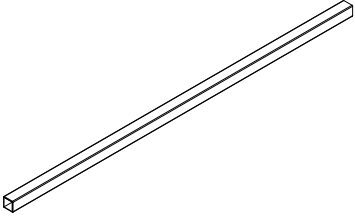
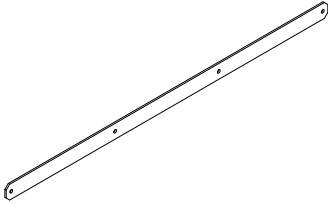
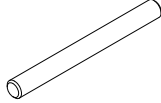

Parts

Check and make sure you get the components on the list, contact us for any missing.

A1		X1	A2		X1
B1		X1	B2		X1
C		X2	D1		X1
D2		X2	E1		X1
E2		X1			

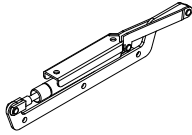
Parts

Check and make sure you get the components on the list, contact us for any missing.

F1		X1	F2		X1
G		X1	J		X4
			K		X1
L		X1	M		X1
N		X6	H		X2
S1	 M4*12	X40	S2	 M4*16	X8
S3	 M4*6	X1			

Assembly steps

Step 1



A1 (X1)



A2 (X1)



S1 (X4)

Ensure that each board is tightly connected.

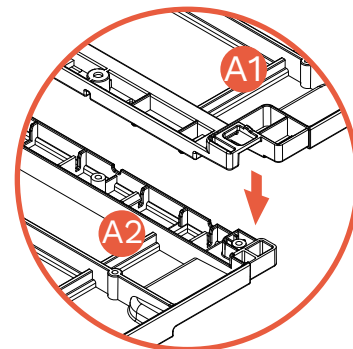
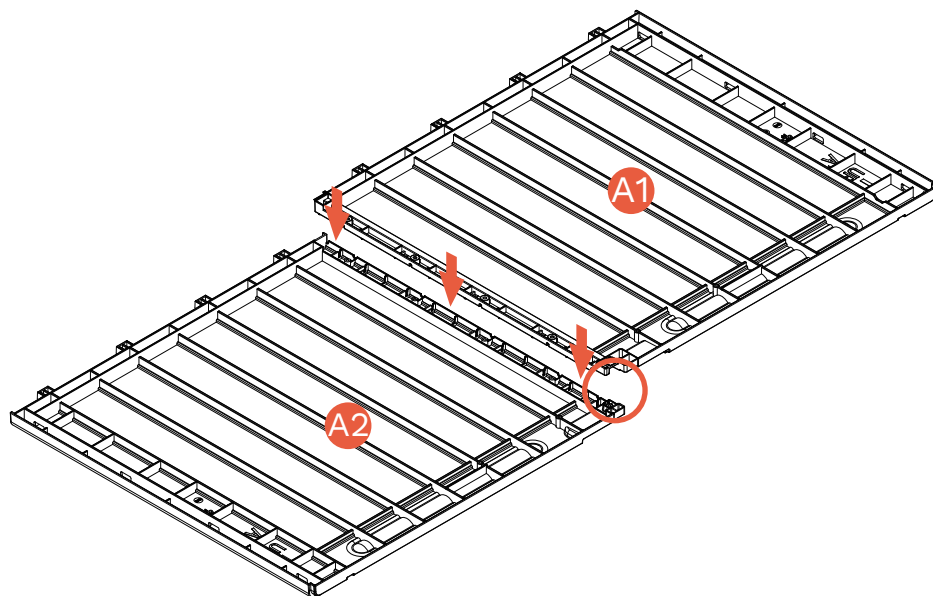

Press **A1** firmly into **A2** until you hear a click.

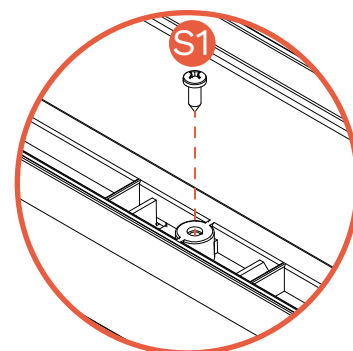
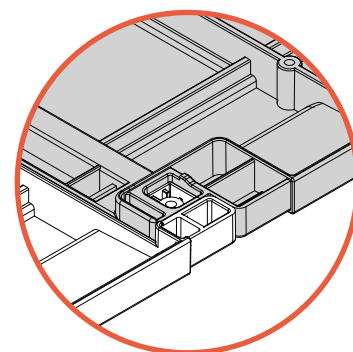
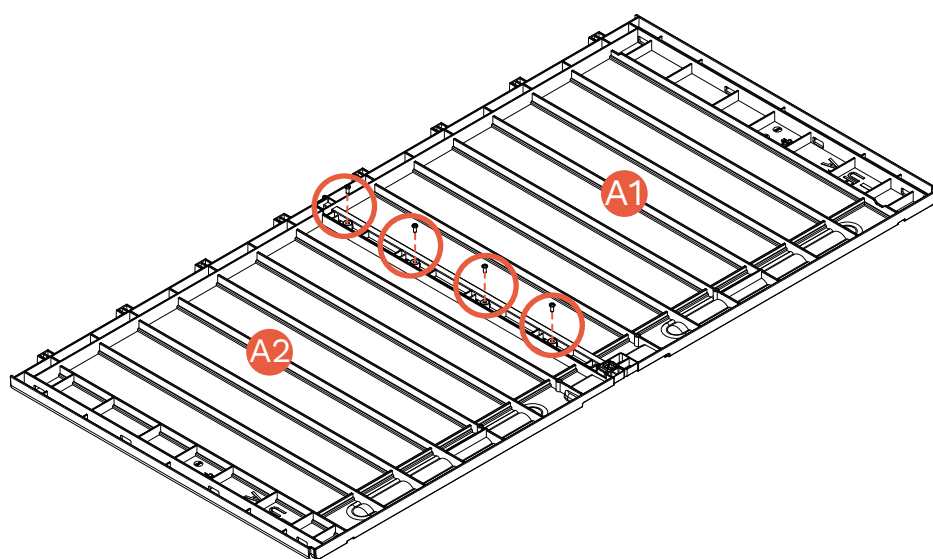

Use a screwdriver to screw **S1*4** into place.

Assembly steps

Step 2

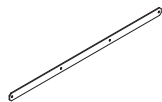

G (X1)



S1 (X4)

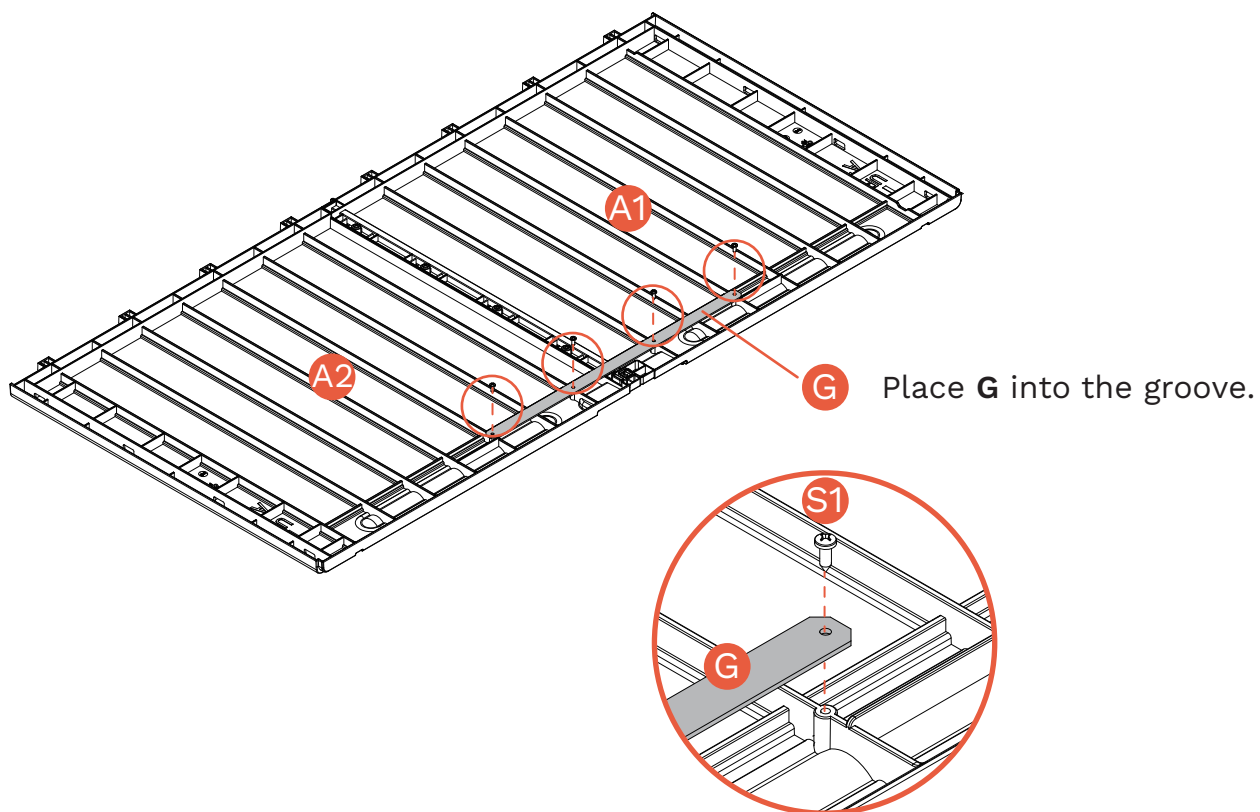

Assembly steps

Step 3



B1 (X1)



B2 (X1)



S1 (X5)

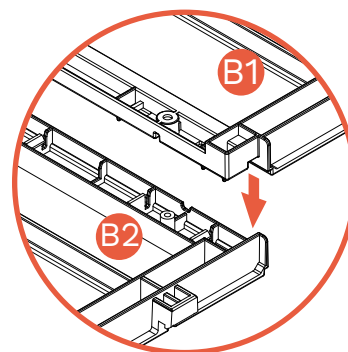
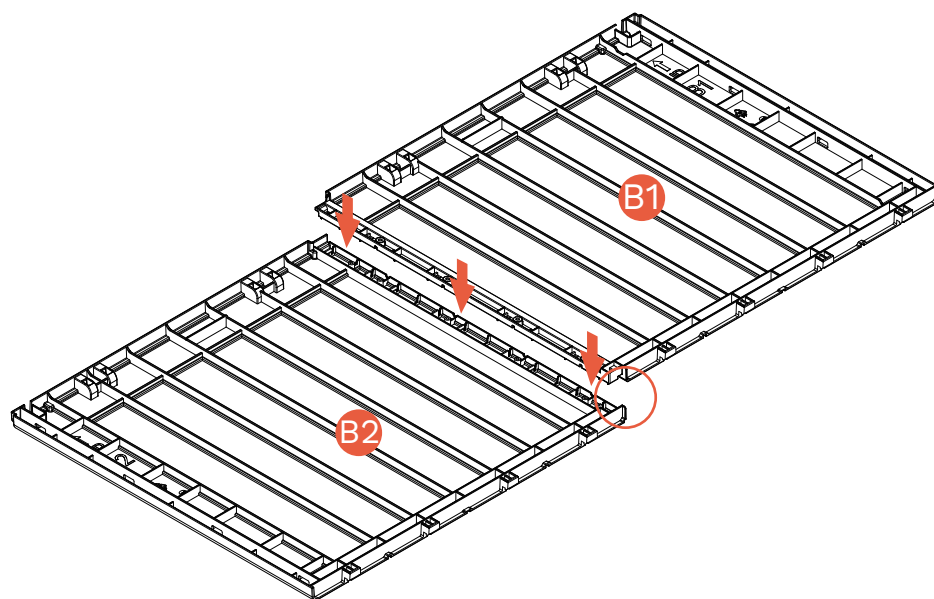

Press **B1** firmly into **B2** until you hear a click.

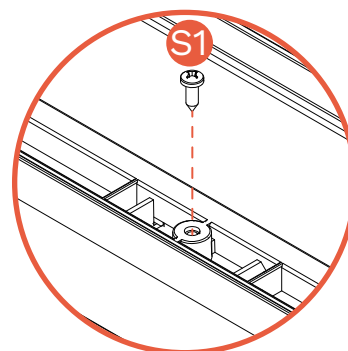
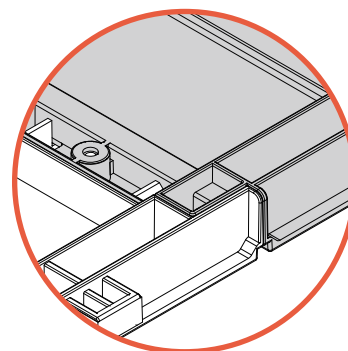
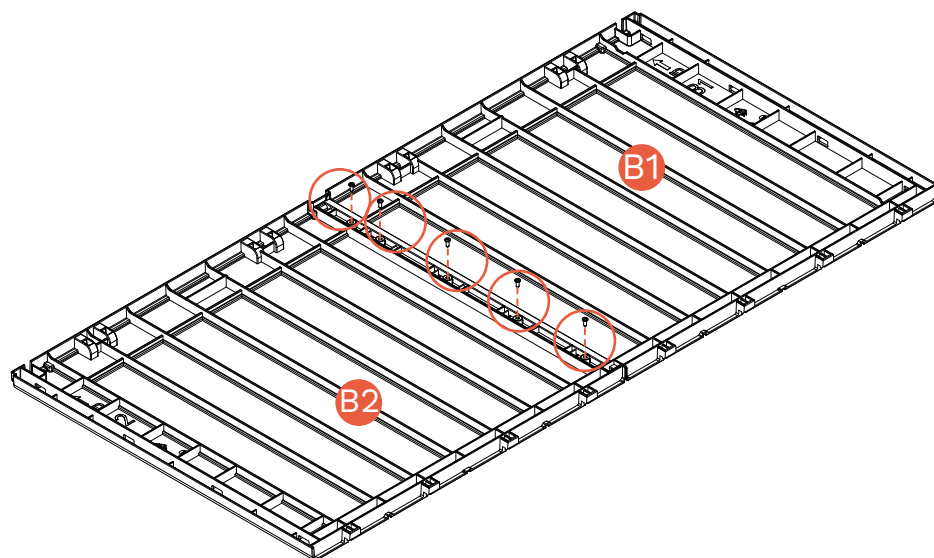

Assembly steps

Step 4

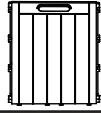

C (X2)

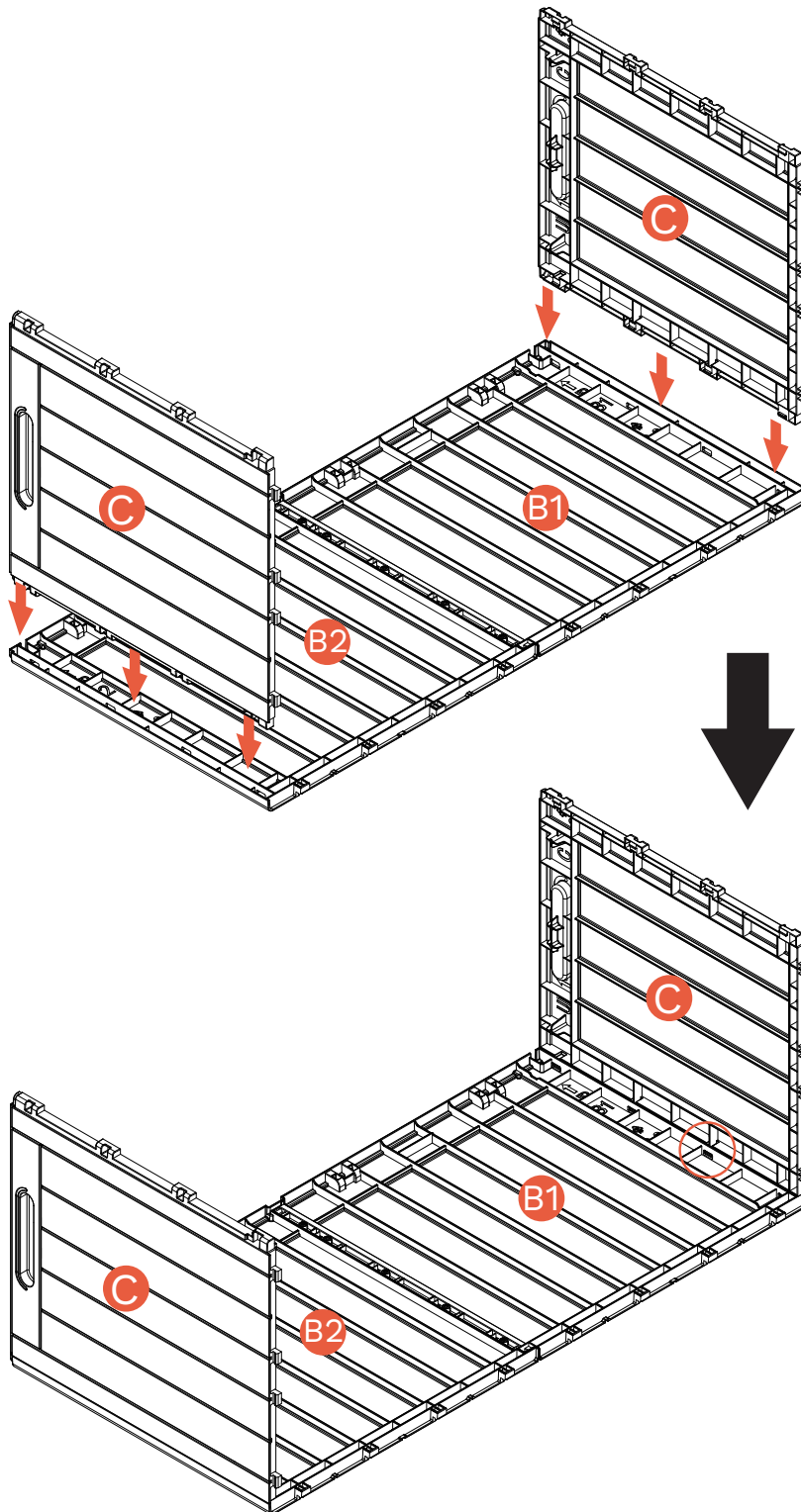

Confirm the positions of panel C and panel B1,B2.

Press C*2 firmly into B1,B2.

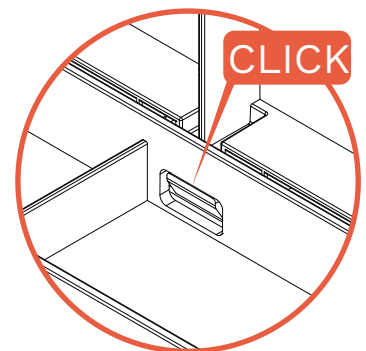

As shown in the figure, this indicates a successful installation.

Assembly steps

Step 5

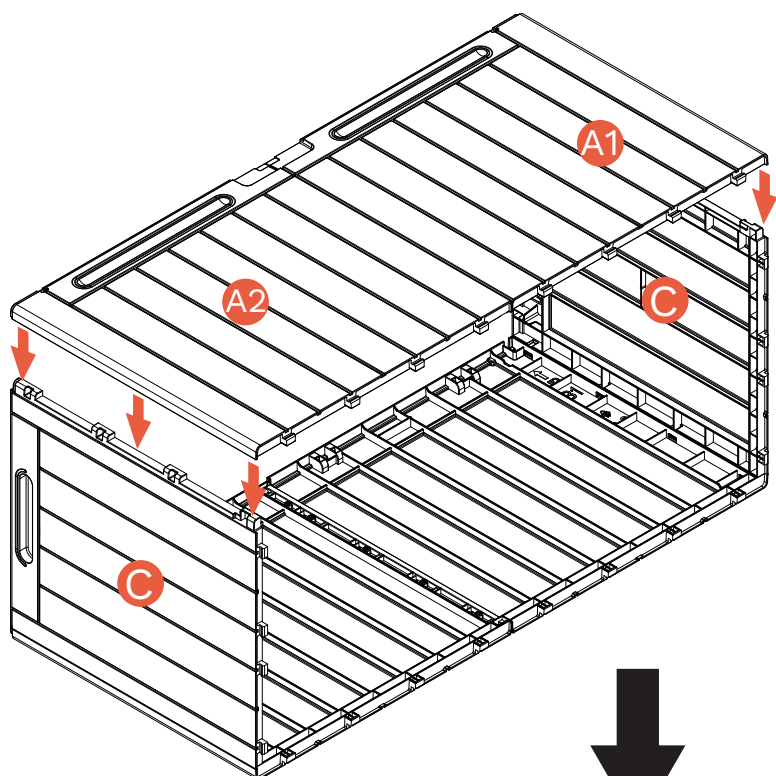

Confirm the position of panel A1,A2 and C.

Press A1,A2 firmly to C.

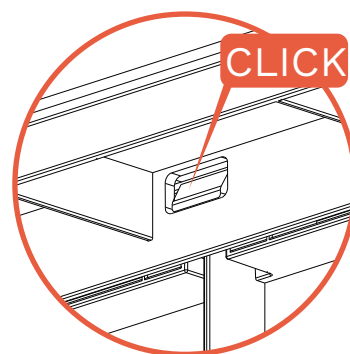
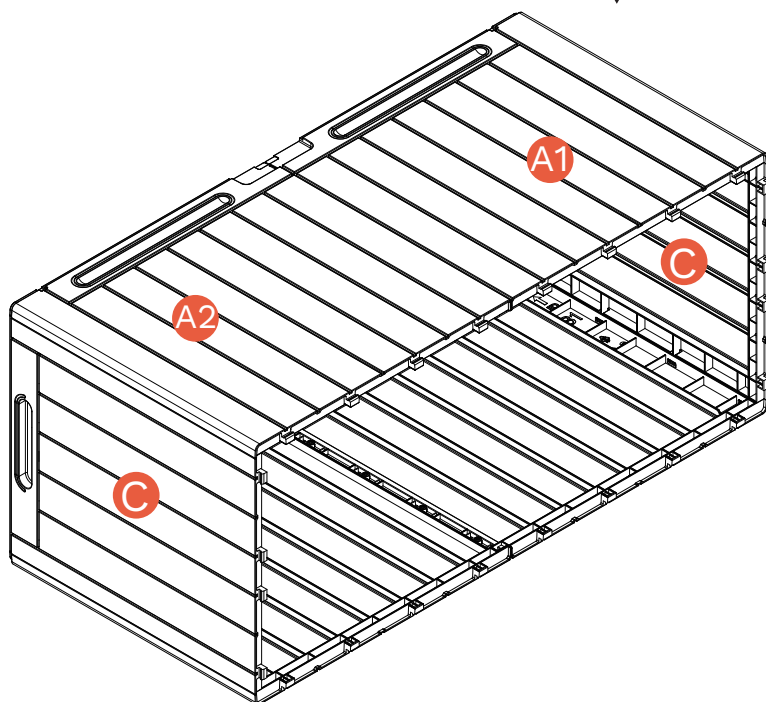

As shown in the figure this indicates a successful installation.

Assembly steps

Step 6

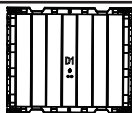

D1 (X1)



D2 (X2)



S1 (X8)

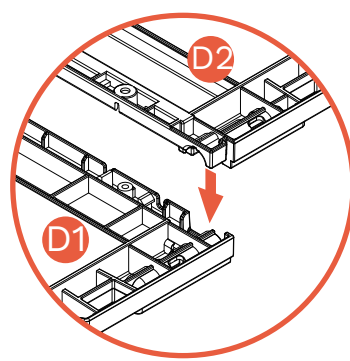
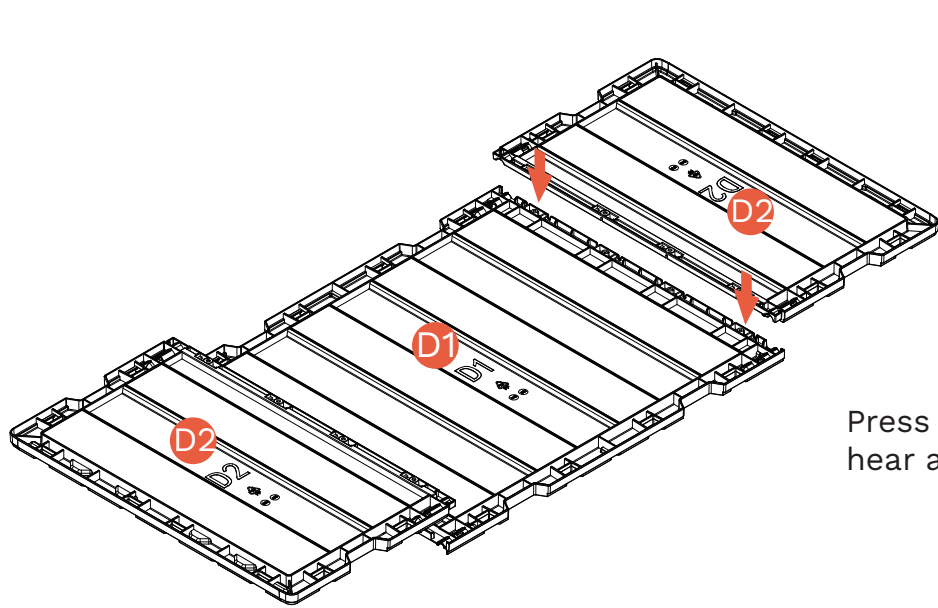

Press **D2** firmly into **D1** until you hear a click.

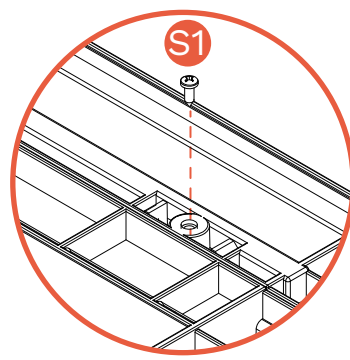
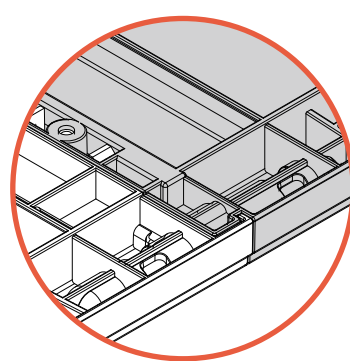
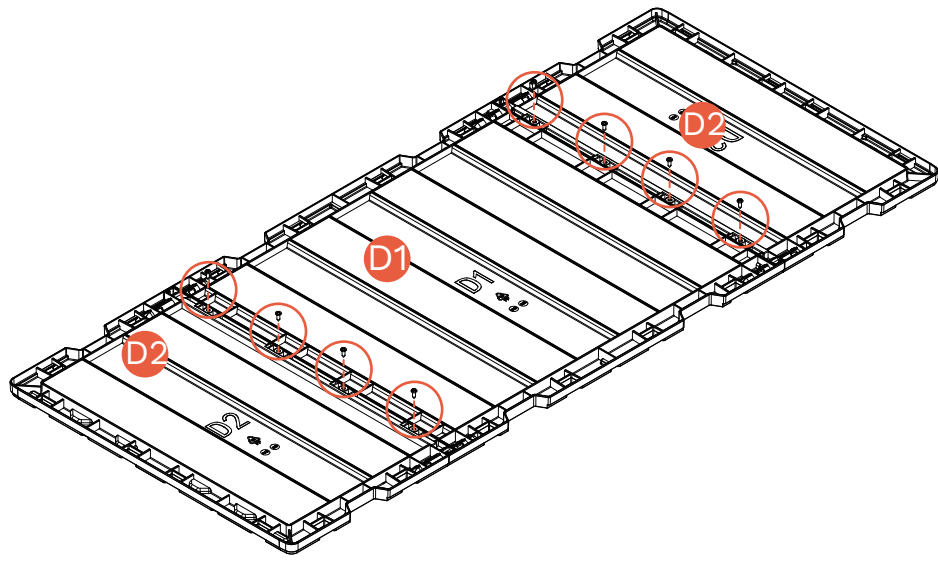

Assembly steps

Step 7

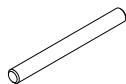

J (X4)

Please flip the board **D2,D1,D2** to their front side.

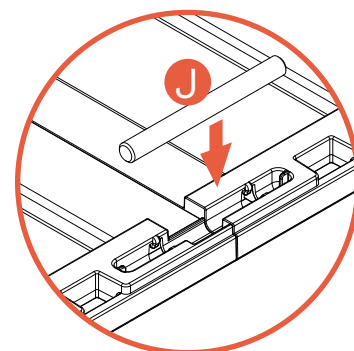
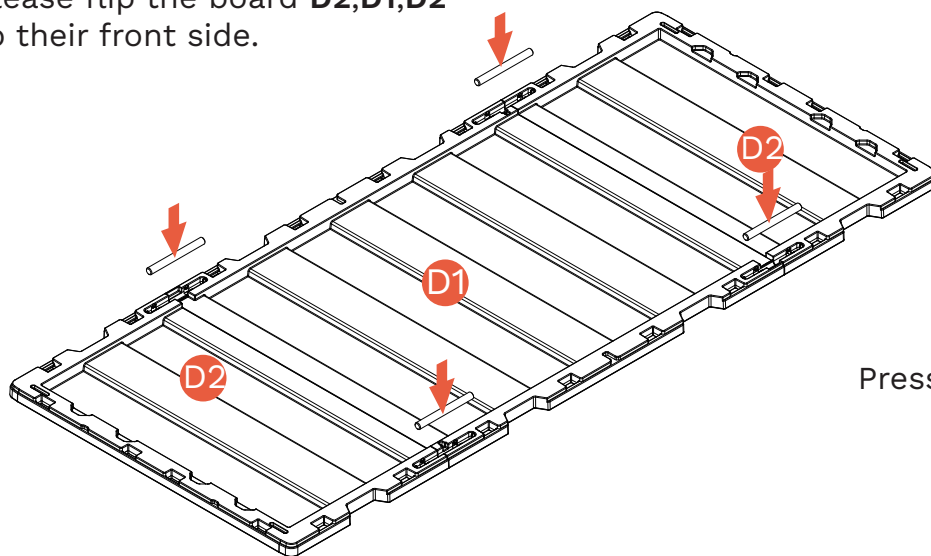

Press **J*4** firmly into **D2,D1,D2**.

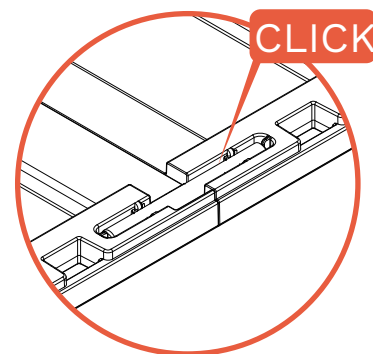
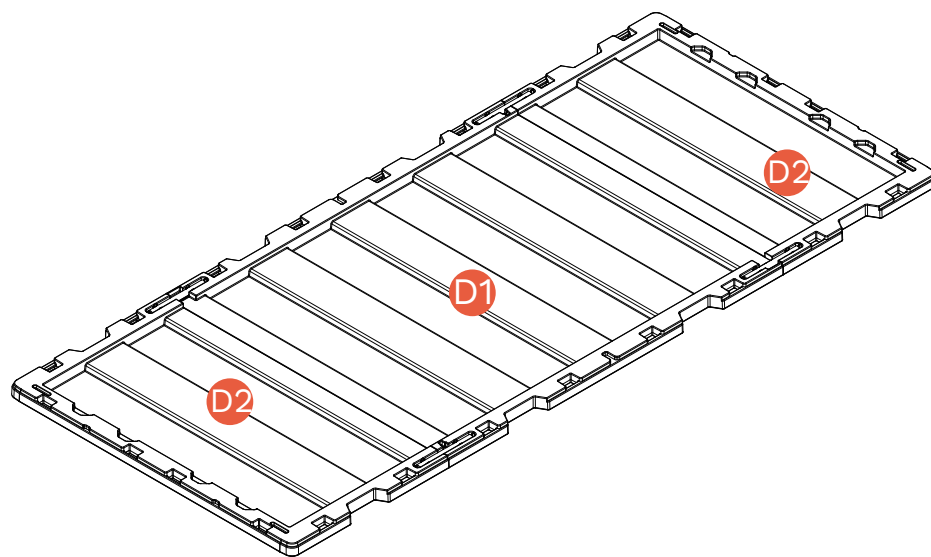

Assembly steps

Step 8

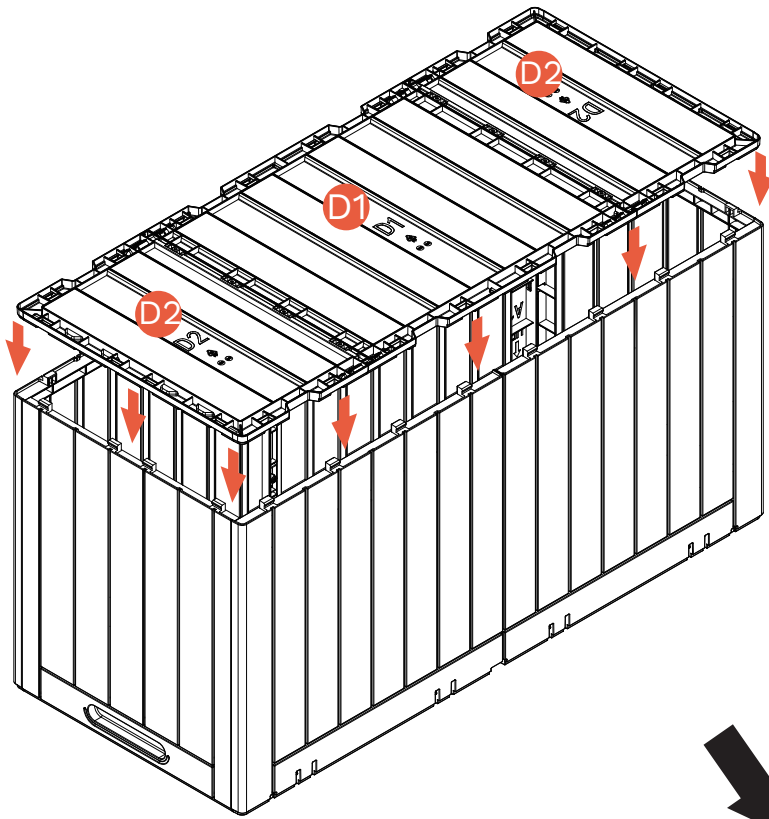

Flip the storage box so the built-in handle is facing down.

Flip **D2,D1,D2** ,press **D2,D1,D2** firmly into storage box.

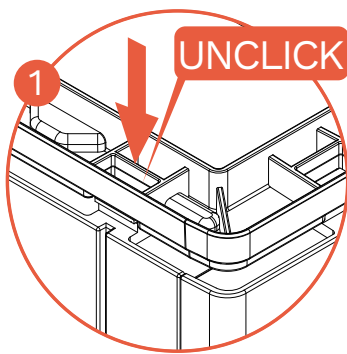

A total of 24 locations.

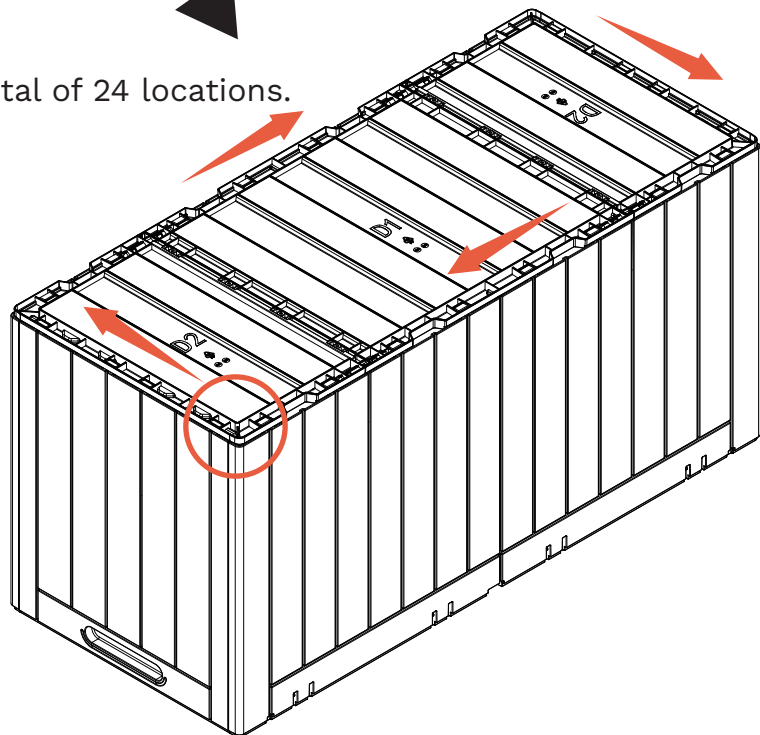
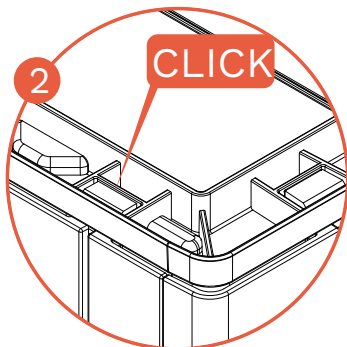

Assembly steps

Step 9

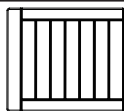

E1 (X1)



E2 (X1)



S1 (X5)

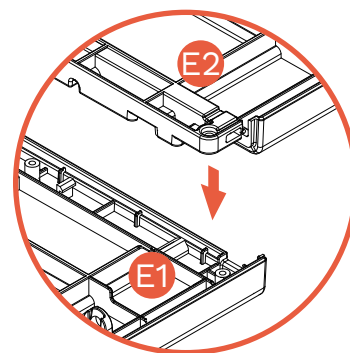
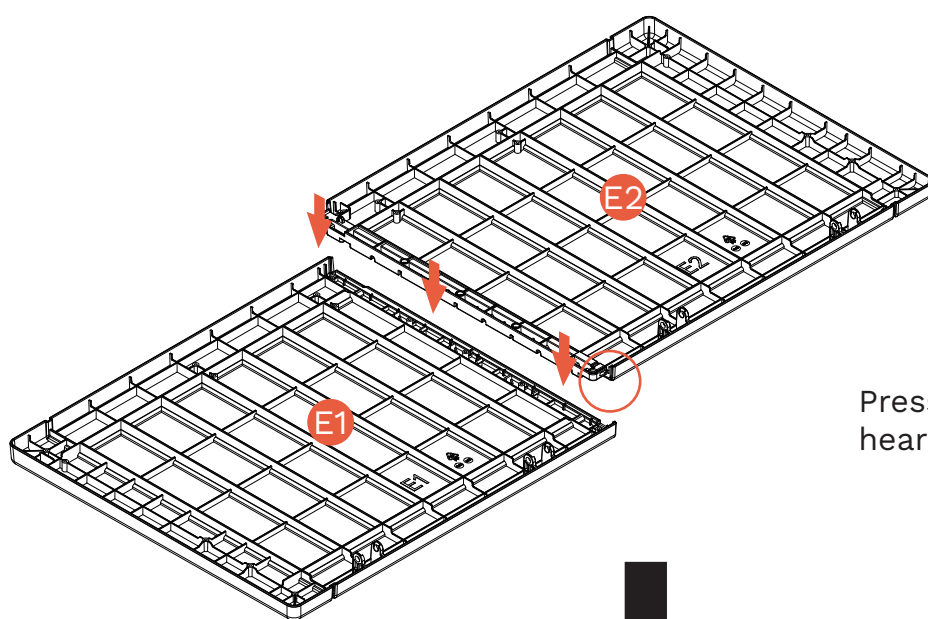

Press **E2** firmly into **E1** until you hear a click.

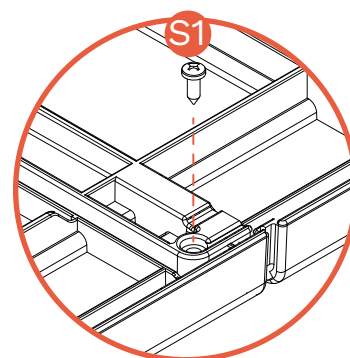
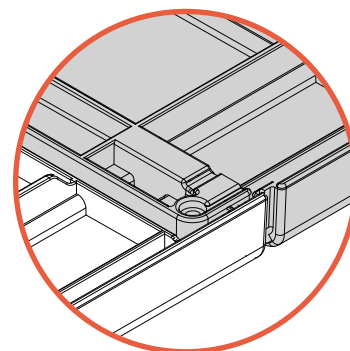
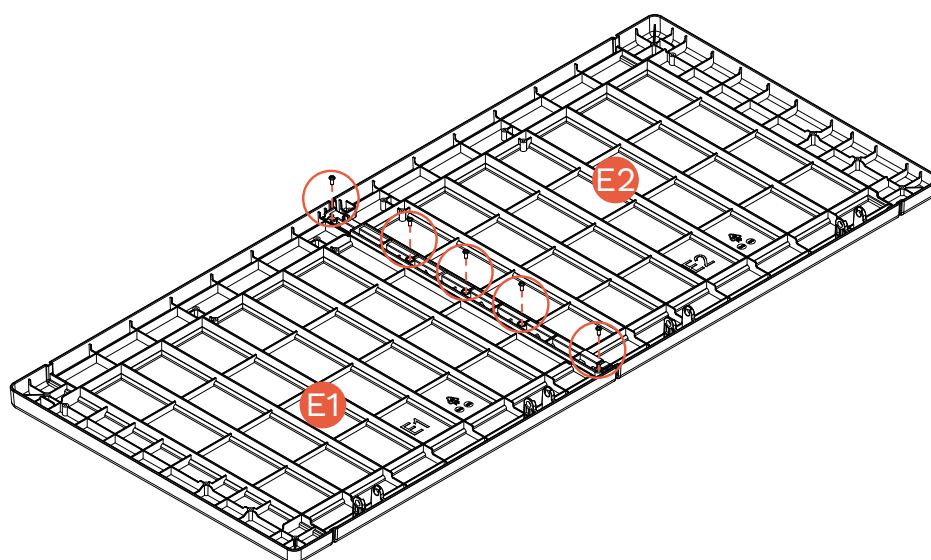

Assembly steps

Step 10

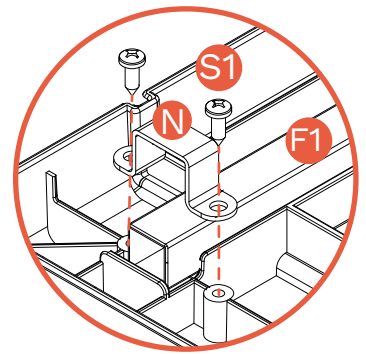
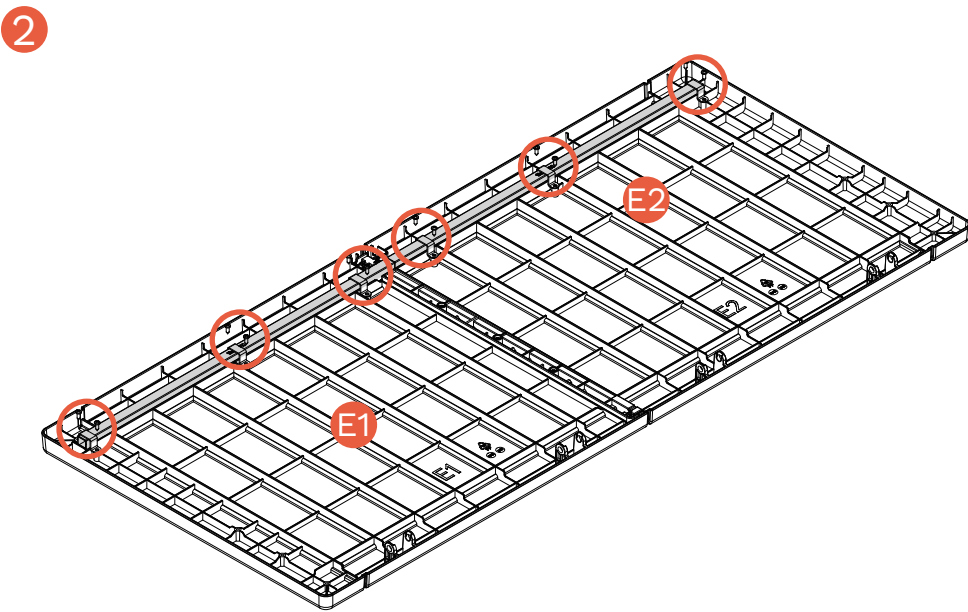
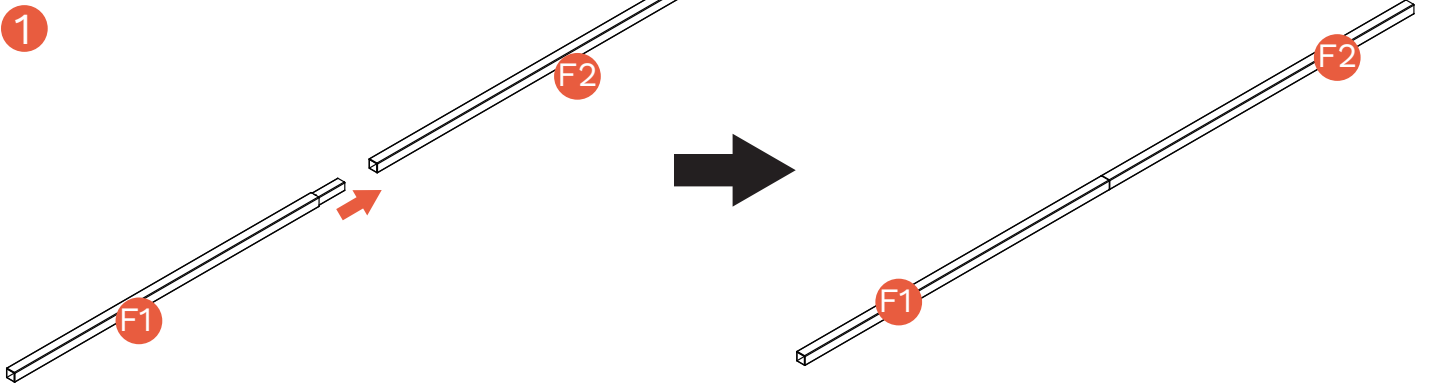
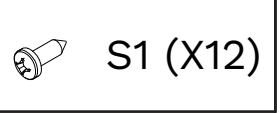
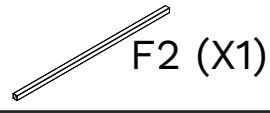

Assembly steps

Step 11



L (X1)



S1 (X2)

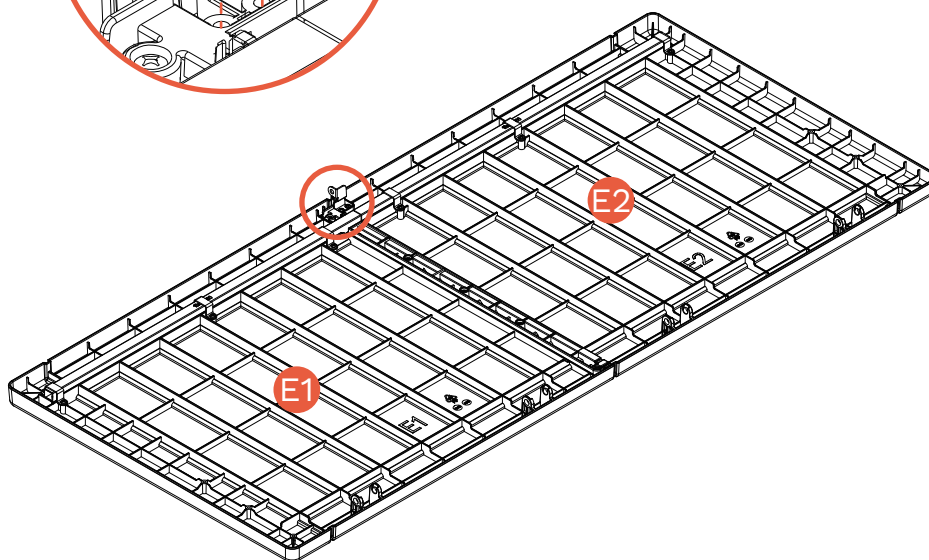
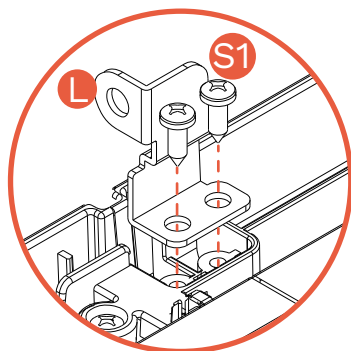

Assembly steps

Step 12

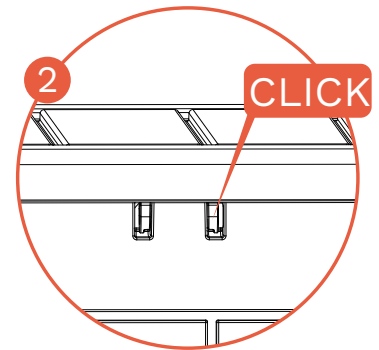
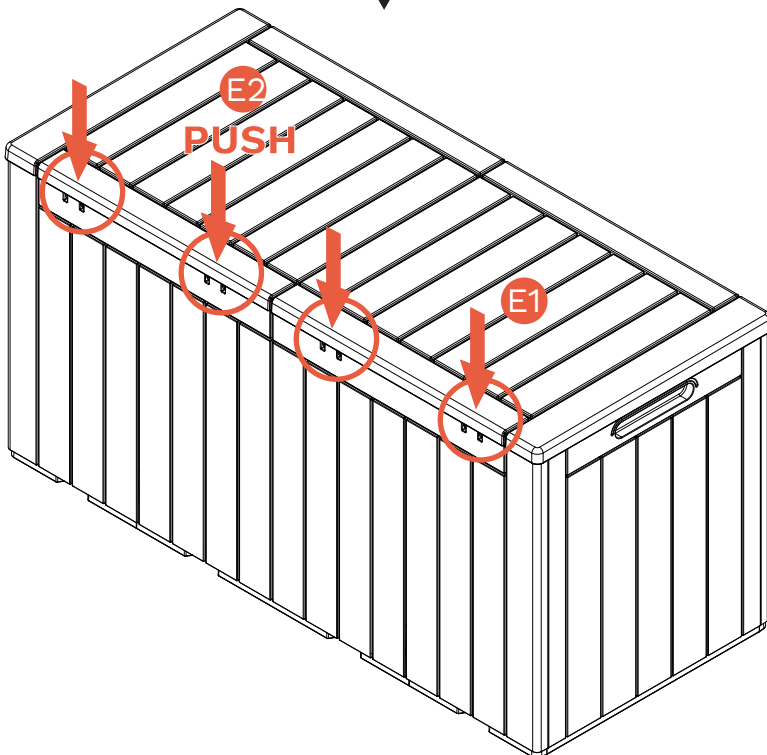
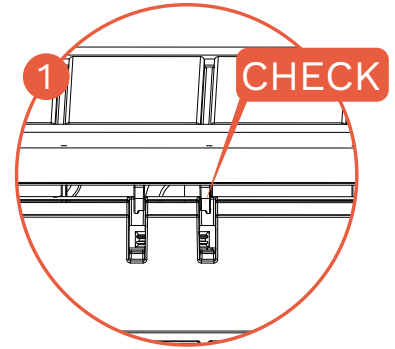
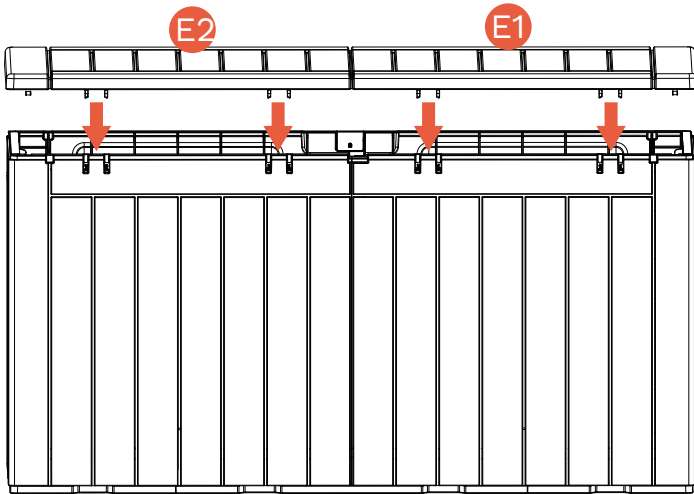

Assembly steps

Step 13

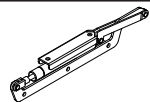

H (X2)



S2 (X8)

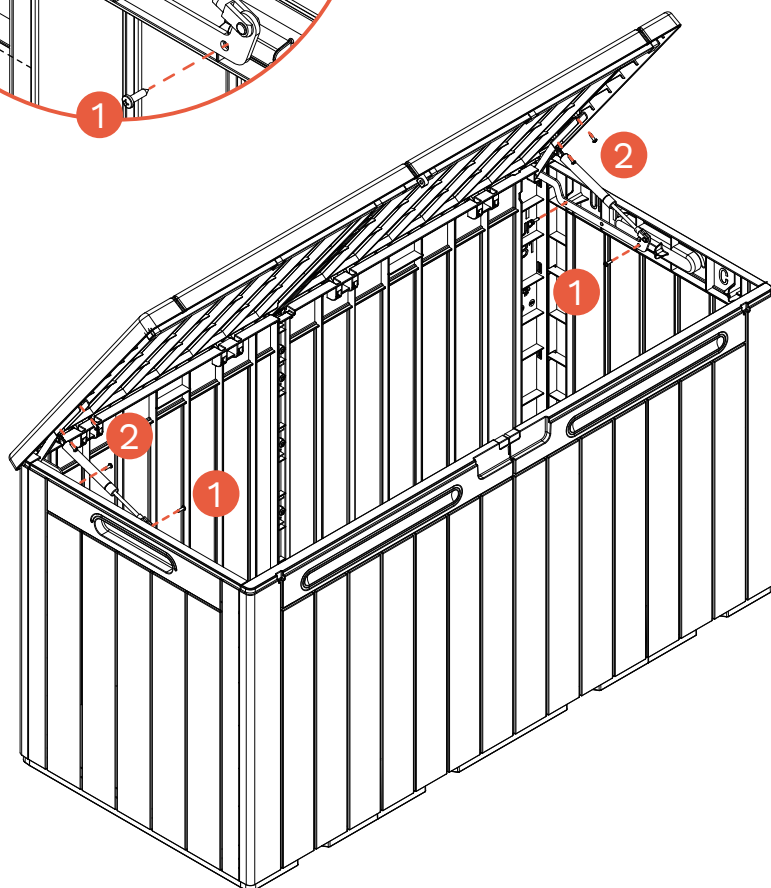
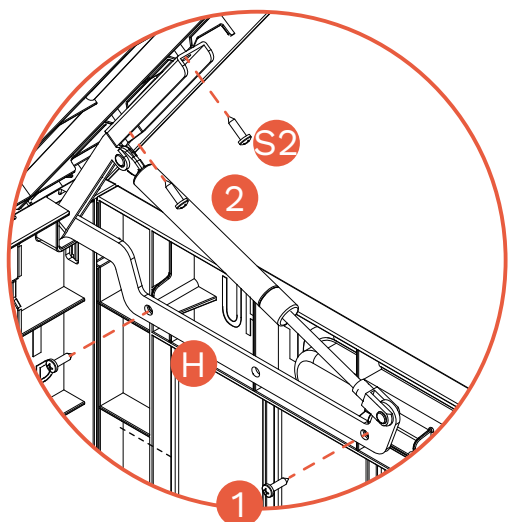

Assembly steps

Step 14



M (X1)



K (X1)



S3 (X1)

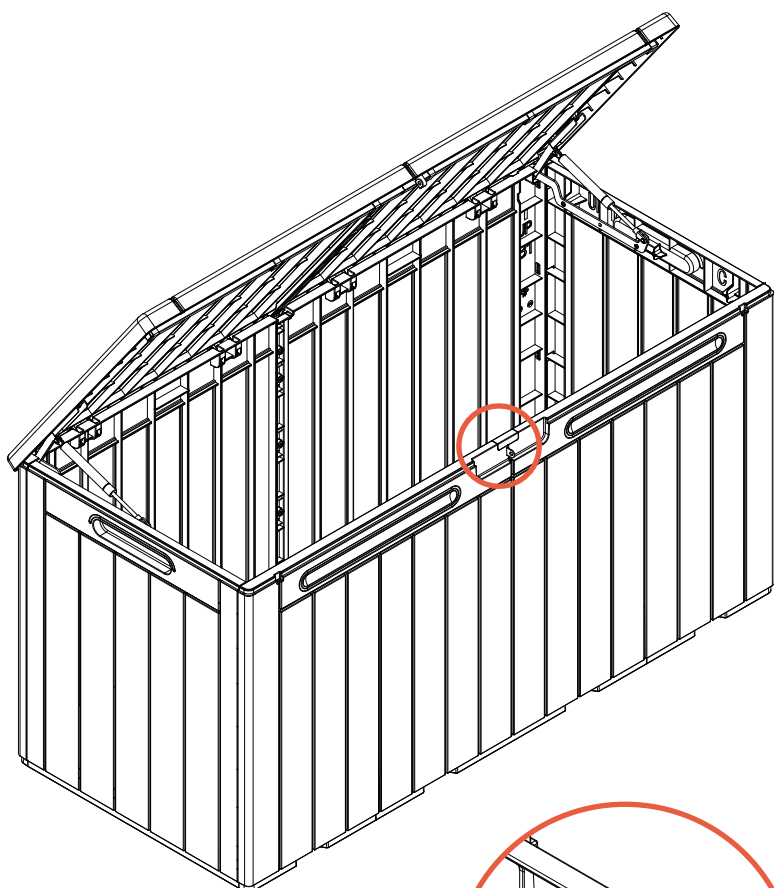

1

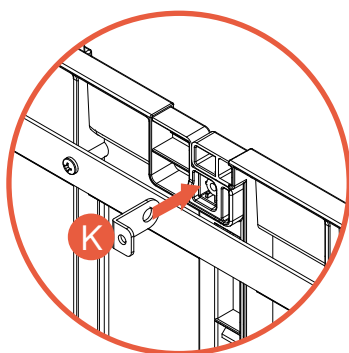

S3

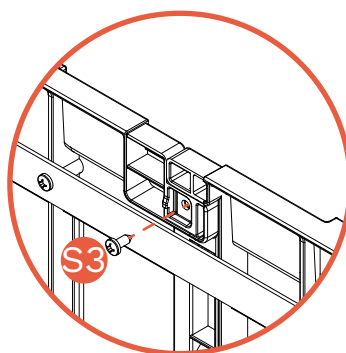

2

