

ONE DOOR TALL CABINET
ARMOIRE HAUTE À UNE PORTE
ARMARIO ALTO CON UNA PUERTA

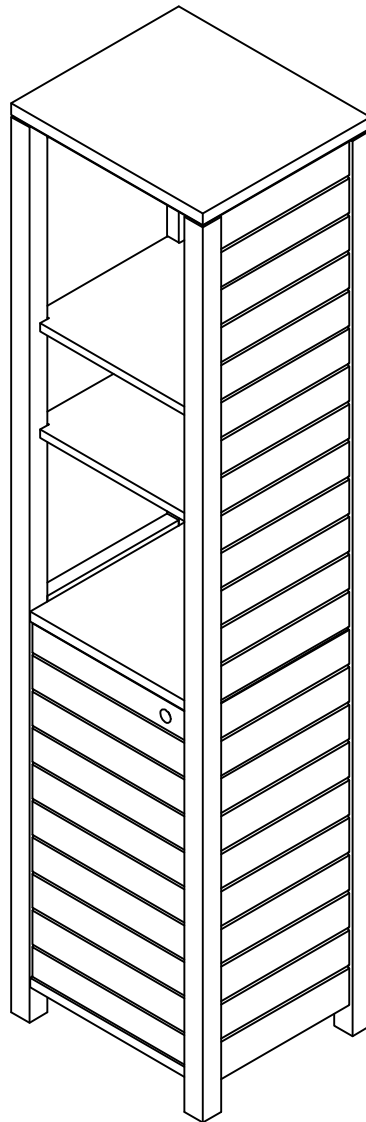

We are here to help!

Before you return it - contact us.

We do our best to insure that your furniture arrives in excellent condition. In the event that a part is damaged or missing, we will be happy to provide you with replacement parts, at no charge, within 30 days of purchase, providing the parts are available in our warehouse and the item purchased is part of our current inventory. In order to receive spare parts, at no charge, you must provide proof of purchase within 30 days.

If you need assistance with assembly or replacement parts, please call our Customer Service, prior to returning the item to the store.

Nous sommes là pour vous aider!

Avant de retourner le produit, veuillez communiquer avec nous.

Nous faisons tout en notre pouvoir pour que vous receviez votre meuble en parfait état. Toutefois, si une pièce est endommagée ou manquante, se fera un plaisir de vous envoyer gratuitement la pièce de rechange, dans les 30 jours suivant l'achat, à condition que nous ayons la pièce en stock et que le produit acheté fasse partie de notre inventaire courant. Afin de recevoir gratuitement la pièce de rechange, vous devez fournir une preuve d'achat dans un délai de 30 jours.

Si vous avez besoin d'une pièce de rechange ou d'aide pour l'assemblage, veuillez communiquer avec le Service à la clientèle avant de retourner le produit au magasin.

¡Estamos aquí para ayudarle!

Antes de regresar el producto, comuníquese con nosotros.

Hacemos todo lo posible para que su mobiliario se le entregue en excelentes condiciones. En caso de que falte una pieza o esté dañada, le enviará con gusto la pieza de repuesto sin ningún costo dentro de los 30 días posteriores a la compra, siempre y cuando tengamos en existencia las piezas en nuestros almacenes y que el artículo comprado forme parte de nuestro inventario actual. Para recibir piezas de repuesto, sin costo adicional, debe enviarnos el comprobante de compra dentro de los 30 días después de la compra.







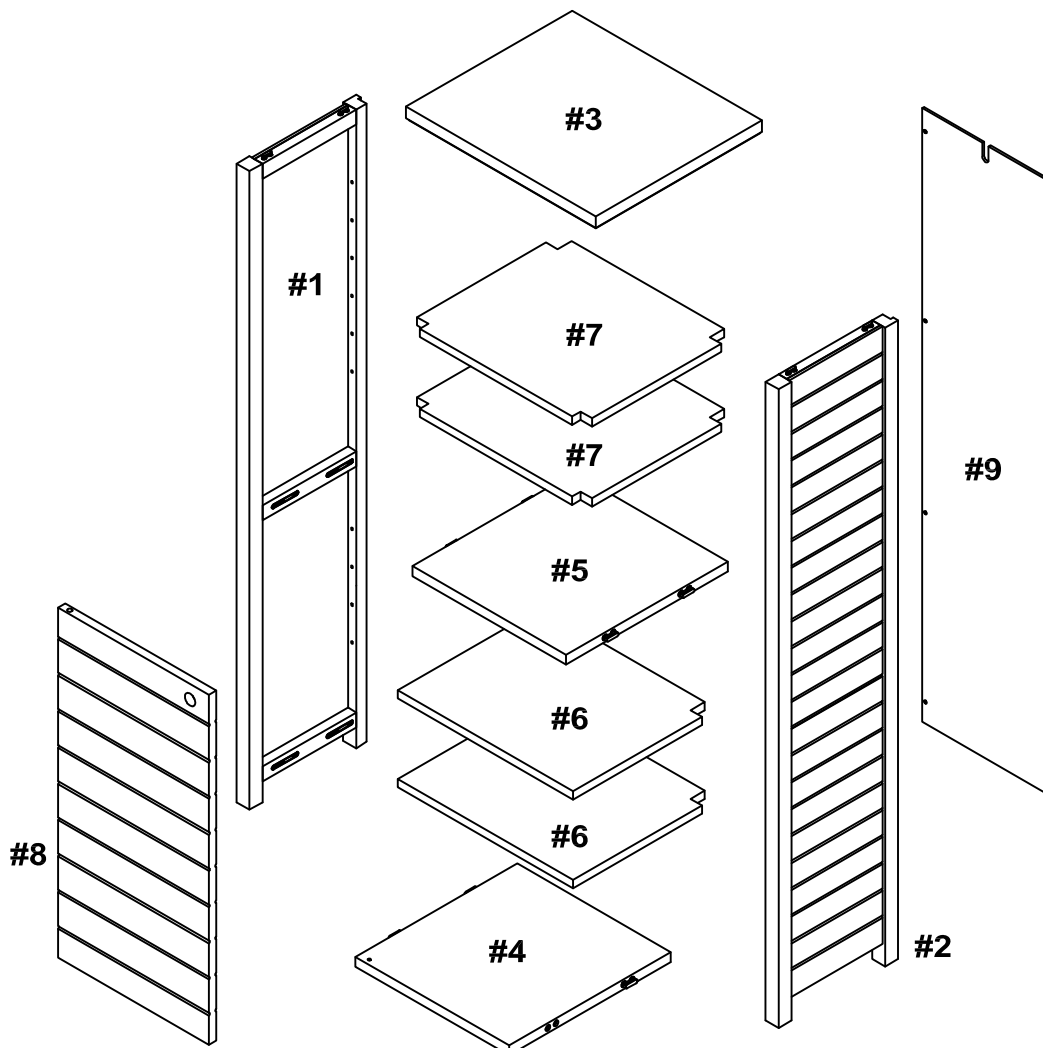

Si necesita ayuda para ensamblar su producto o para obtener piezas de repuesto, llame al Servicio al Cliente antes de devolver el artículo a la tienda.

Part list / Liste des pièces / Lista de piezas

#1	Left panel / Panneau gauche / Panel izquierdo	01
#2	Right panel / Panneau droit / Panel derecho	01
#3	Top panel / Panneau supérieur / Panel superior	01
#4	Bottom panel / Panneau inférieur / Panel inferior	01
#5	Shelf / Plateau / Útil	01
#6	Adjustable shelf - bottom / Plateau réglable - inférieure / Estante ajustable - inferior	02
#7	Adjustable shelf - top / Plateau réglable - supérieure / Estante ajustable - superior	02
#8	Door / Porte / Puerta	01
#9	Back panel / Panneau arrière / Panel posterior	01



Hardware list / Liste des pièces / Lista de tornillería

A	Metal plate / Plaque de métal / Placa de metal		01
B	Screw (M4x12mm) / Vis / Tornillo		01
C	Bolt (M6x15mm) / Boulon / Perno		08
D	Shelf support / Supports pour tablette / Soporte para estante		16
E	Pin / Nip / Pin		02
F	Screw (M4x50mm) / Vis / Tornillo		01
G	Flat washer / Rondelle plate/ Arandela plana		01
H	Wall anchor / Ancrages muraux / Anclaje de pared		01

Tools required / Outils requis / Herramientas requeridas

Philips screwdriver / Tournevis philips / Destornillador estándar		Not supplied / Non fourni / No incluido
---	--	---

IMPORTANT:

1. Do not tighten bolts completely until all bolts are completely lined up and inserted into holes / nuts.
2. Do not over tighten screws and bolts to avoid stripping.
3. Please use hand tools to assemble this product. Do not use power tools.

IMPORTANT:

1. Ne serrez pas complètement les boulons jusqu'à ce que tous les boulons soient complètement alignés et insérés dans les trous / écrous.
2. Ne pas trop serrer les vis et les boulons pour éviter le décapage.
3. Utilisez des outils à main pour assembler ce produit. N'utilisez pas d'outils électriques.

IMPORTANTE:

1. No apriete completamente los pernos hasta que todos los tornillos estén alineados completamente y se inserten en los agujeros / tuercas.
2. No apriete demasiado los tornillos y los pernos para evitar que se pelen.
3. Utilice herramientas de mano para montar este producto. No utilice herramientas eléctricas.

1.

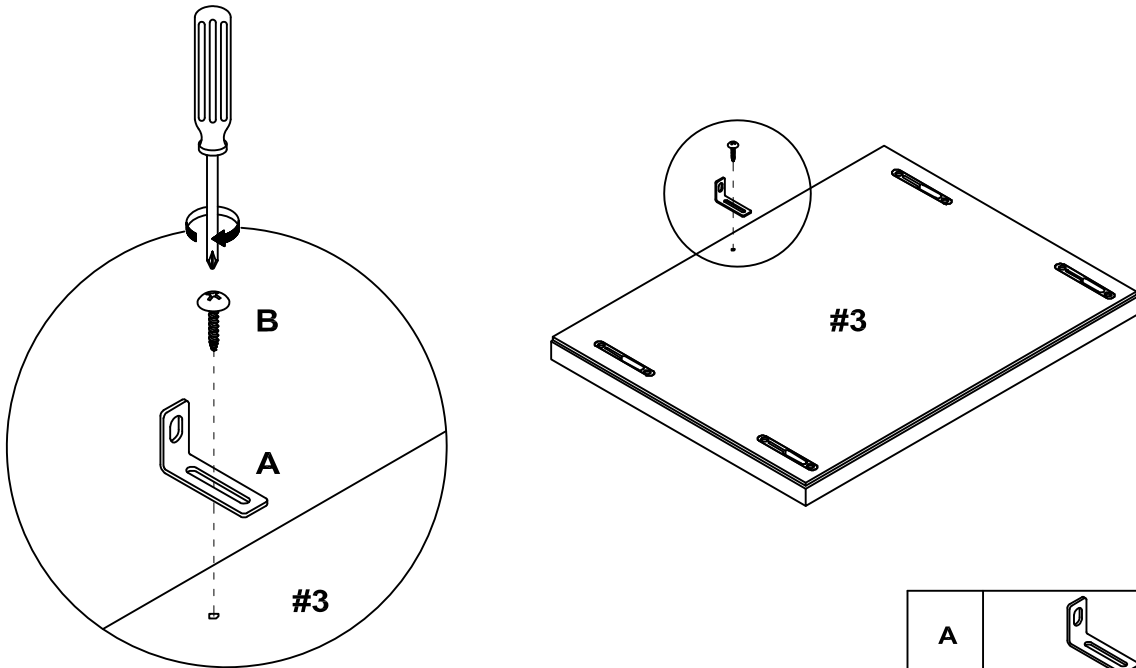

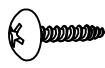
A		01
B		01

2.

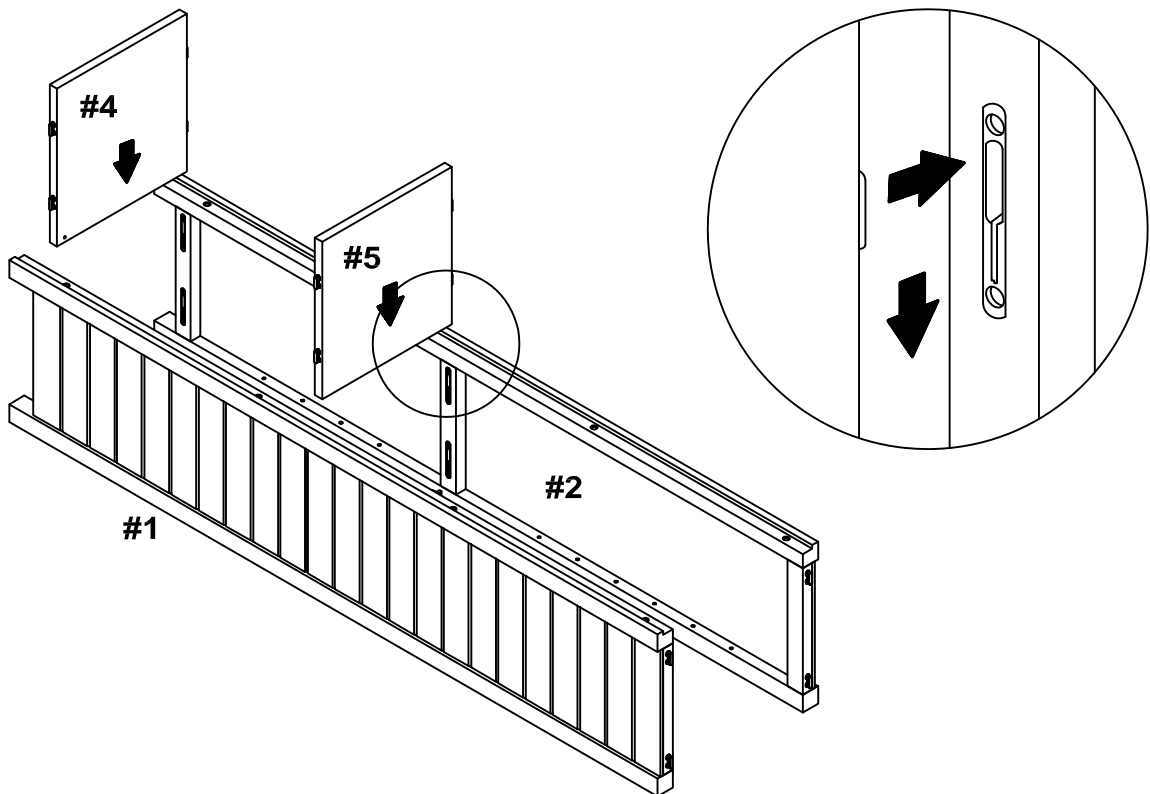

3.

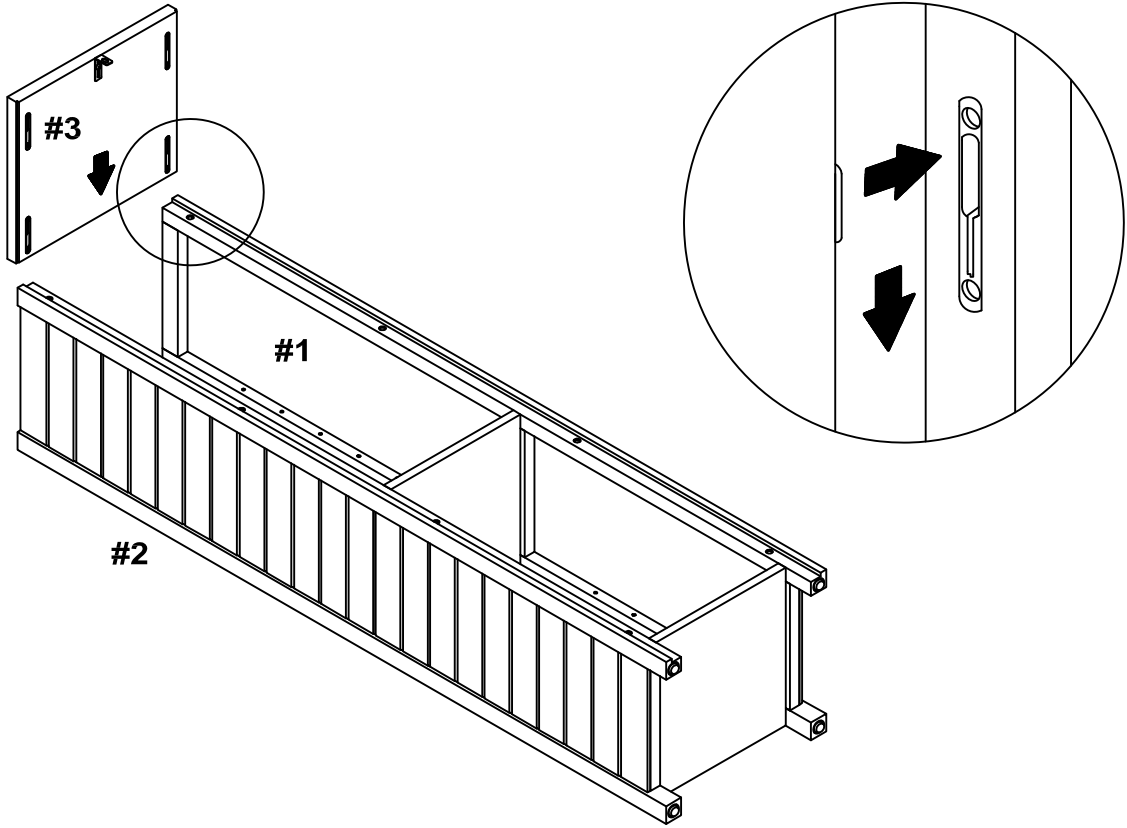

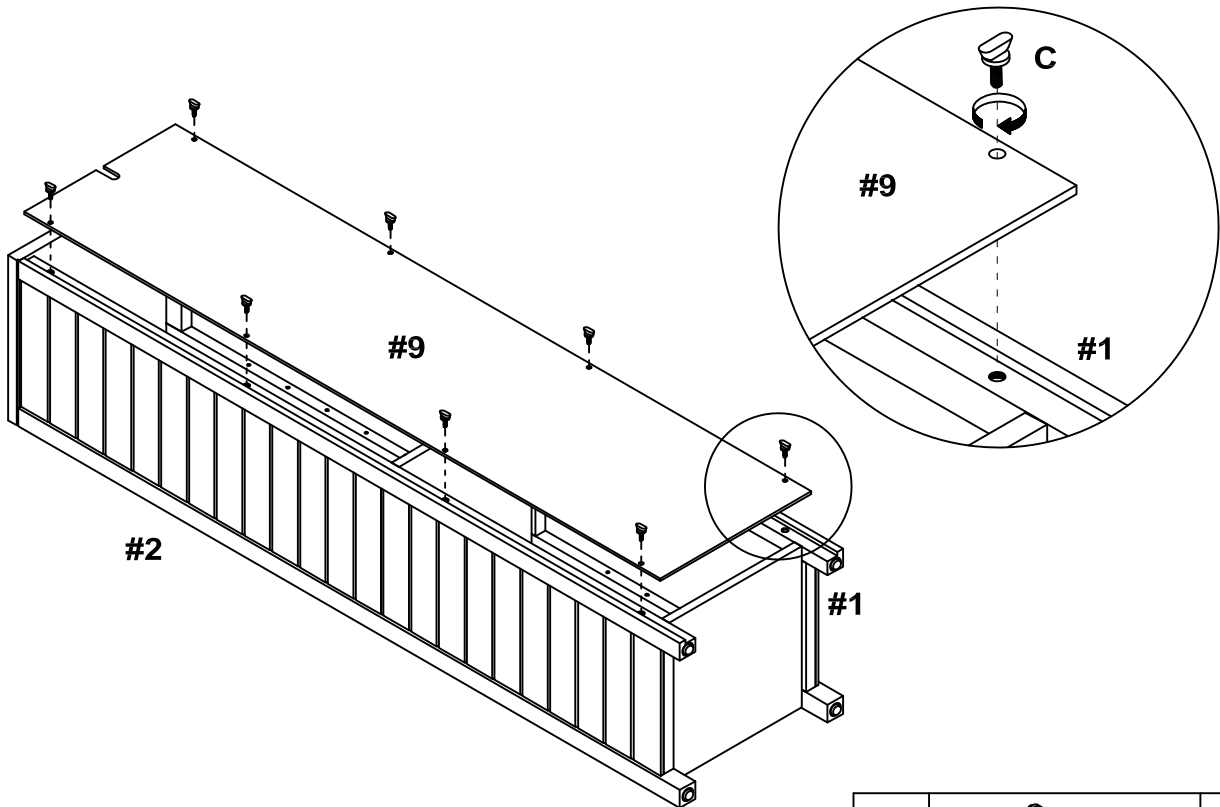

4.

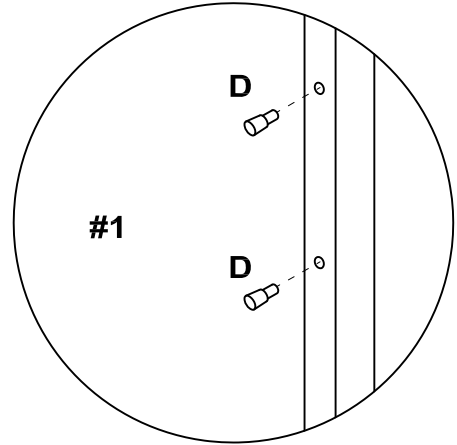
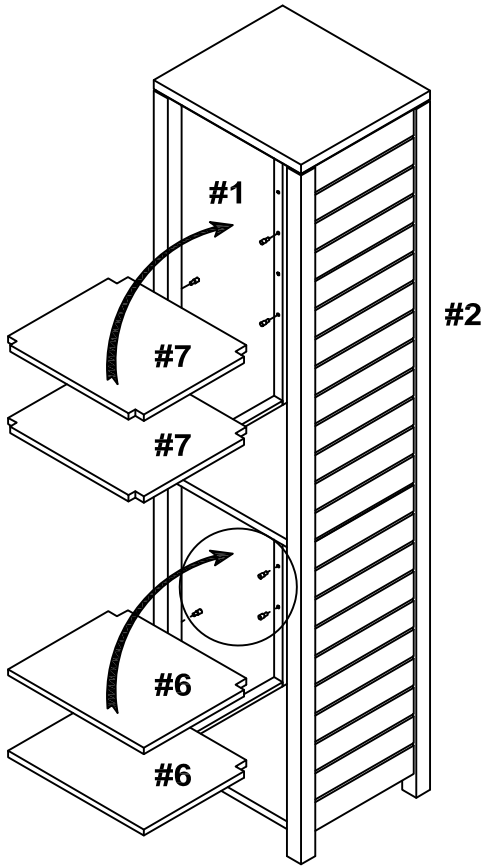

C		08
---	---	----

5.



D		16
---	---	----

6.

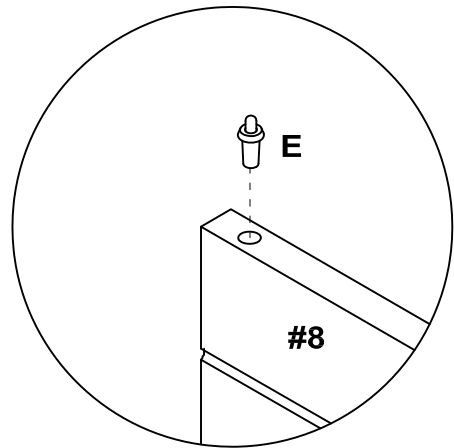
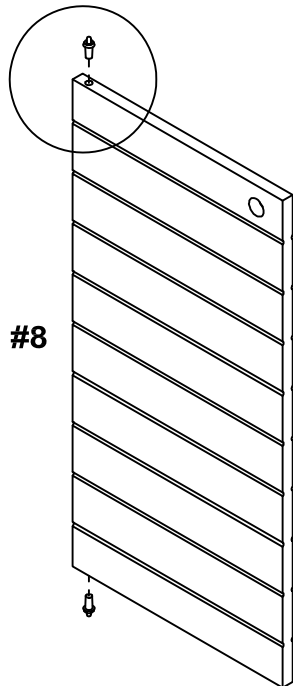

E		02
---	---	----

7.

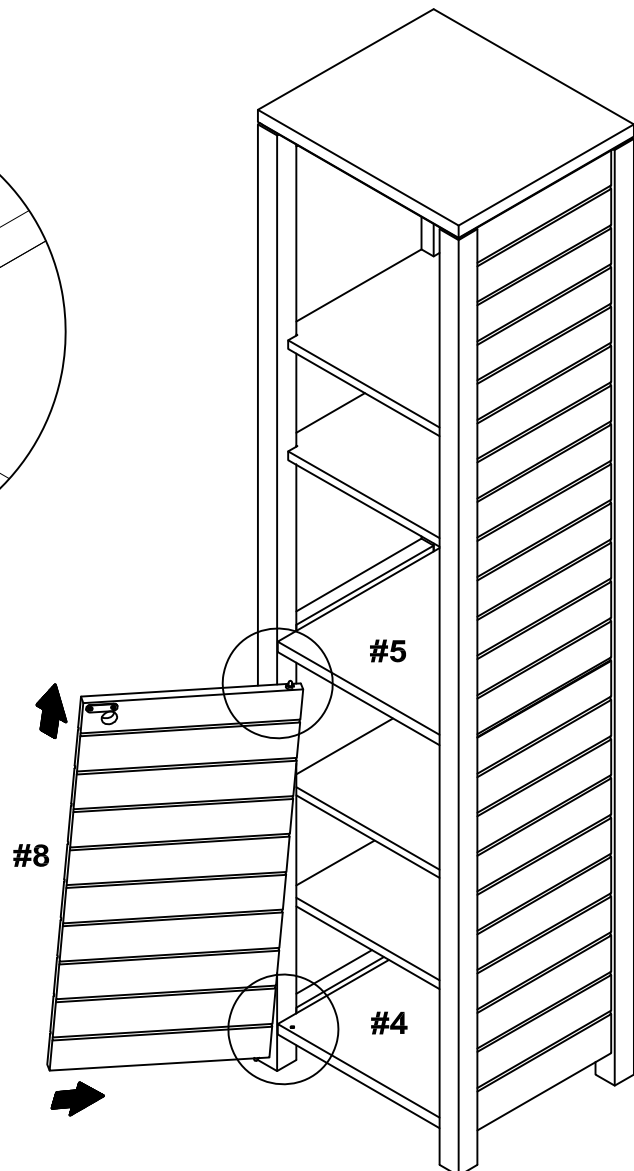
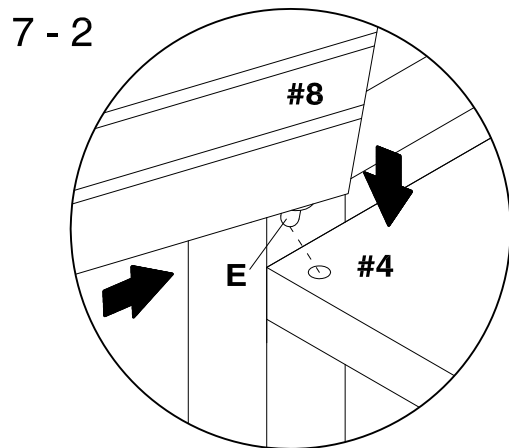
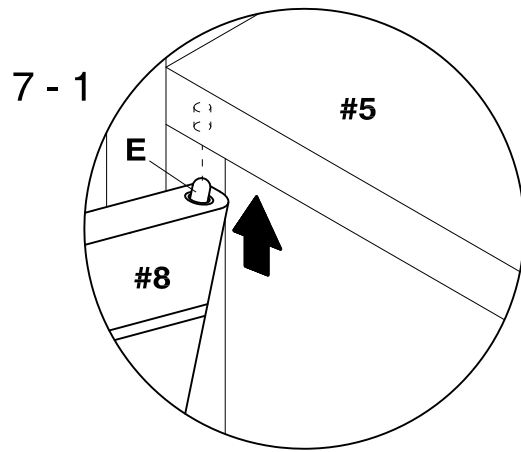

! WARNING

Serious or fatal crushing injuries can occur from furniture tipover. To help prevent tipover:

- Install tipover restraint provided.
- Place heaviest items in the lower drawers.
- Unless specifically designed to accommodate, do not set TVs or other heavy objects on top of this product.
- Never allow children to climb or hang on drawers, doors or shelves.
- Never open more than one drawer at a time. (OR)
- Do not defeat or remove the drawer interlock system.

Use of tipover restraints may only reduce, but not eliminate, the risk of tipover.

This is a permanent label. Do not remove.

! AVERTISSEMENT

Le basculement du meuble peut causer de graves blessures par écrasement, voire la mort. Pour empêcher le basculement:

- Installer les dispositifs antibasculement fournis.
- Ranger les articles les plus lourds dans les tiroirs du bas.
- À moins qu'il ne soit conçu à cette fin, éviter de placer un téléviseur ou un objet lourd sur le dessus de ce meuble.
- Ne jamais permettre à des enfants de monter sur les tiroirs, portes ou tablettes, ni de s'y suspendre.
- Ne jamais ouvrir plus d'un tiroir à la fois. (OU)
- Ne pas altérer ni retirer le système de verrouillage du tiroir.

L'utilisation d'un dispositif antibasculement ne peut que diminuer, et non éliminer, le risque de basculement.

Cette étiquette est permanente. Ne pas tenter de l'enlever.

! ADVERTENCIA

El vuelco del mueble puede causar lesiones por aplastamiento e incluso la muerte. Para evitar que el mueble se vuelque:

- Instale los dispositivos antivuelco proporcionados.
- Guarde los artículos más pesados en los cajones inferiores.
- Evite colocar un televisor o un objeto pesado encima del mueble, salvo si éste último ha sido diseñado específicamente para dicho fin.
- No permita que los niños suban sobre los cajones, las puertas o los estantes ni que se cuelguen de dichas piezas.
- No abra más de un cajón a la vez. (O)
- No altere ni quite el sistema de cerradura del cajón.

El uso de un dispositivo antivuelco sólo disminuye el riesgo de vuelco, no lo elimina.

Esta etiqueta es permanente. No trate de quitarla.

PLEASE NOTE: For your safety, to prevent the danger of this unit tipping over, it is important that the wall anchors are properly attached.

S'IL VOUS PLAÎT NOTE: Pour votre sécurité, pour éviter le danger de cette unité de basculement, il est important que les chevilles sont correctement fixés.

NOTA: Para su seguridad, para evitar el peligro de esta unidad se vuelque, es importante que los anclajes de pared estén bien fijados.

8.

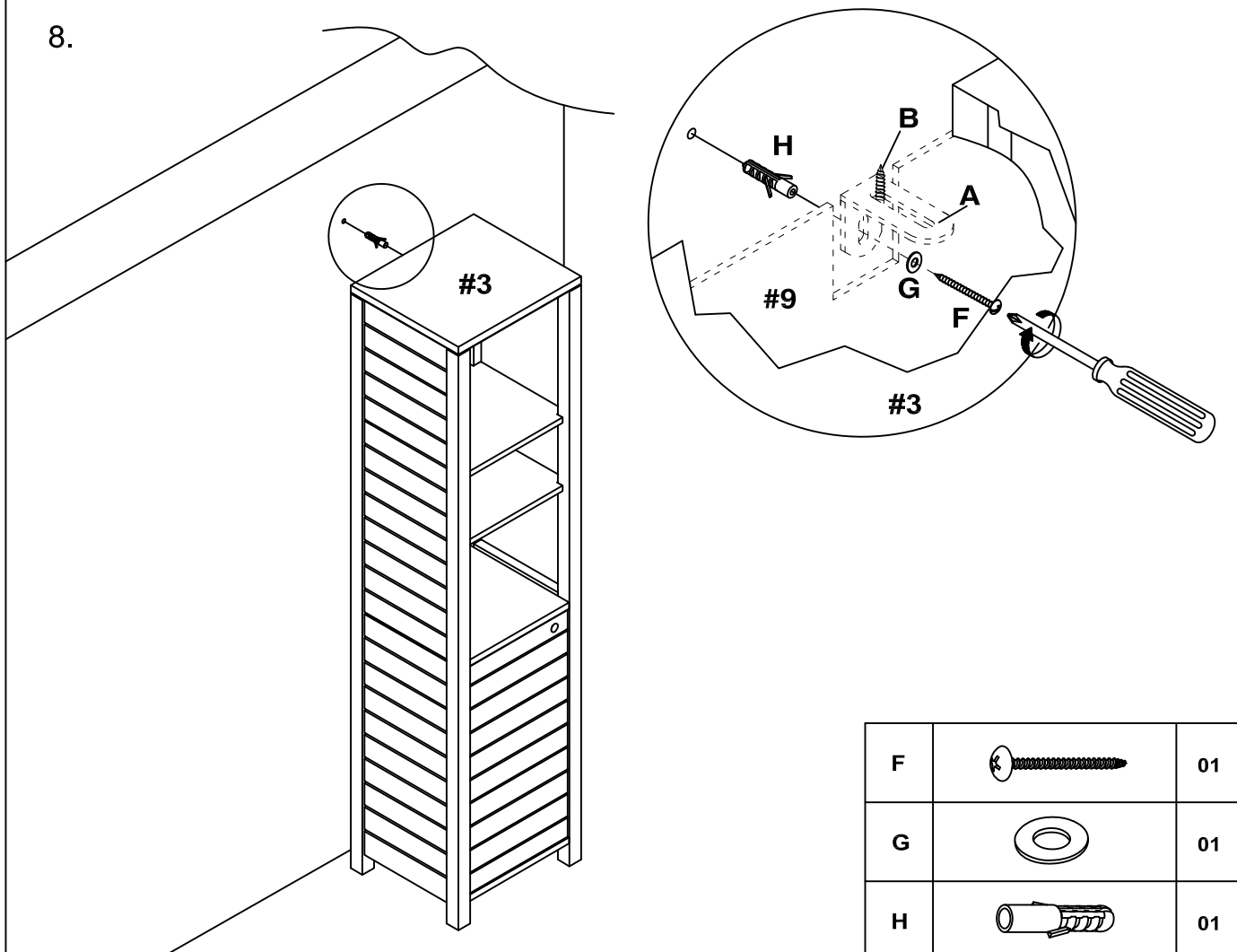

9.

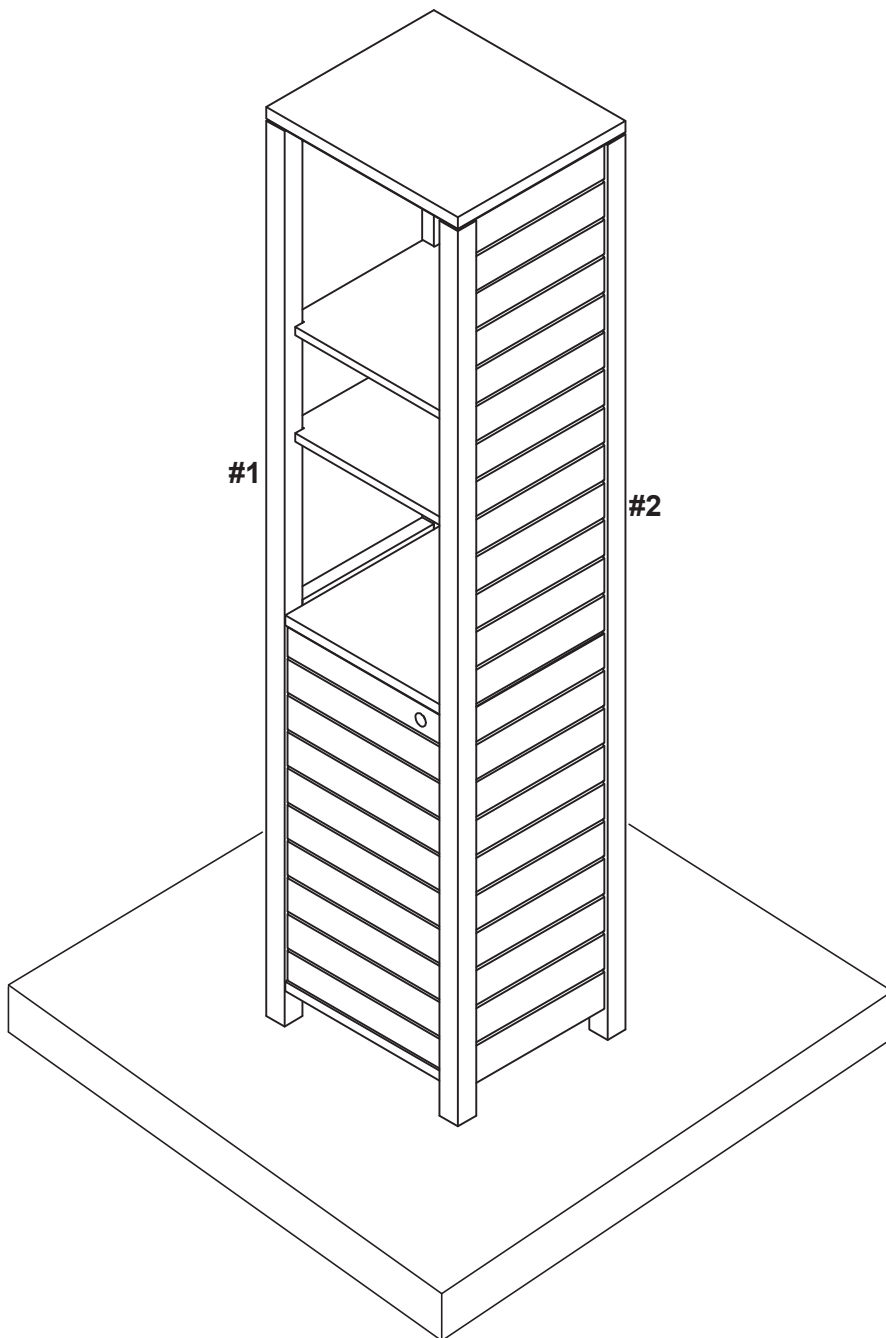
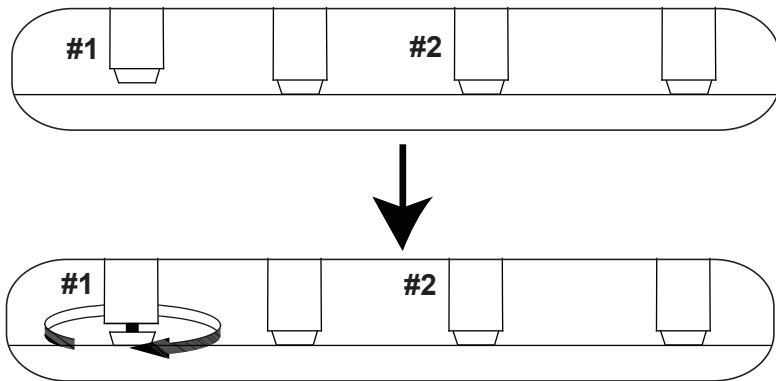

LIMITED 6 MONTHS WARRANTY

WHAT IS COVERED

This product is covered under our manufacturer's 6 months limited warranty. To ensure your complete satisfaction, this warranty to the original purchaser this supplied item is free from defects in material and workmanship, as of the date of purchase, and that it will, under normal use and proper care, remain so for six months after the date of purchase.

Replacement of missing or initially defective parts will be sent, at no charge, for a period of 30 days from the date of purchase with valid proof of purchase providing the parts are available in our warehouse and the item purchased is part of our current inventory.

WHAT IS NOT COVERED

It remains the customer's responsibility for freight and packaging charges to and from the customer service center. Labor and material charges to remove or replace parts under this warranty are not covered.

This warranty does not cover: Furniture used for commercial purposes, failures caused by improper installation assembly or by improper care, unreasonable or abusive use, freeze damage, acts of God, rust, purchased parts or return freight and packaging charges. Proof of purchase (dated register receipt) is required for warranty claims.

HOW TO OBTAIN SERVICE

For further information, please contact our customer service department

MADE IN CHINA
FABRIQUÉ EN CHINE
HECHO EN CHINA