

# ASSEMBLY INSTRUCTION

NO.	PART LIST	QTY
1	BOARD 1	1PC
2	BOARD 2	1PC
3	BOARD 3	1PC
4	BOARD 4	2PCS
5	BOARD 5	1PC
6	BOARD 6	1PC
7	BOARD 7	3PCS
8	LEG (L)	1PC
9	LEG (R)	1PC
10	BACK RAIL	1PC

STEP 1  
(SECTION A)

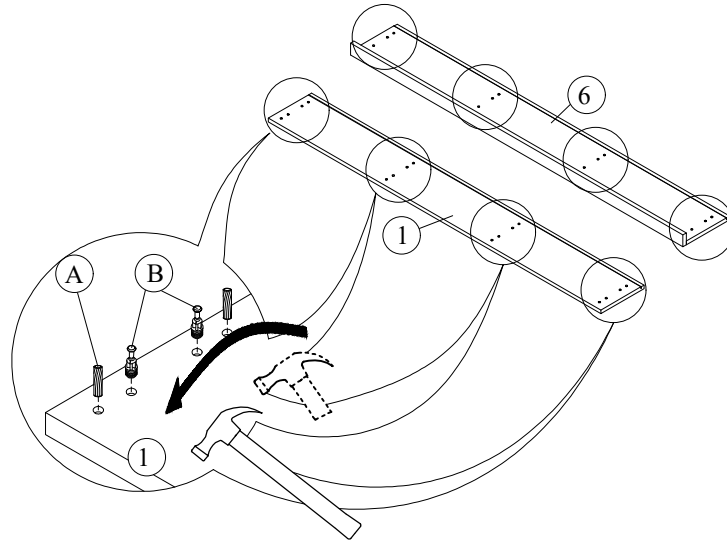

STEP 2

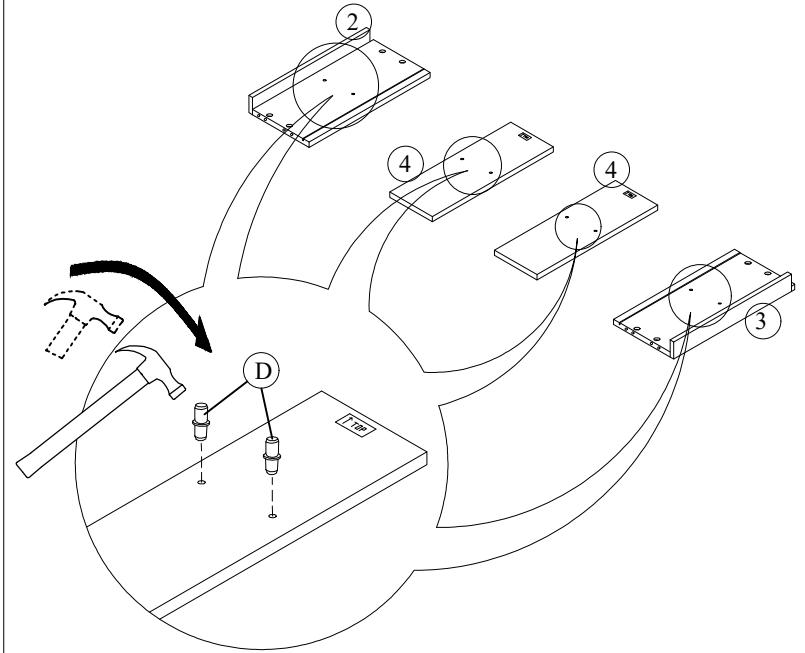

(SECTION A)

ITEM	HARDWARE	QTY
A	WOOD DOWEL M8 x 30mm	16PCS
B	CAM BOLT	16PCS
C	CAM LOCK	16PCS
D	PIN	12PCS
E	COVER CAP	16PCS
F	6/8" NAIL	12PCS
G	L-KEY M4 x 65mm	1PC
H	L-KEY M5 x 65mm	1PC
I	JCBB SCREW M6 x 45mm	9PCS
J	JCBB SCREW M8 x 16mm	4PCS
K	SPRING WASHER (SMALL)	9PCS
L	SPRING WASHER (BIG)	4PCS
M	FLAT WASHER (SMALL)	9PCS
N	FLAT WASHER (BIG)	4PCS

STEP 3

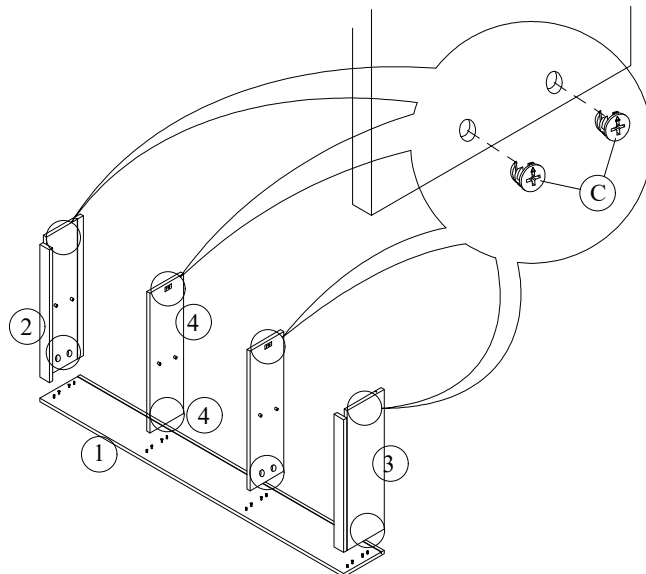

STEP 4

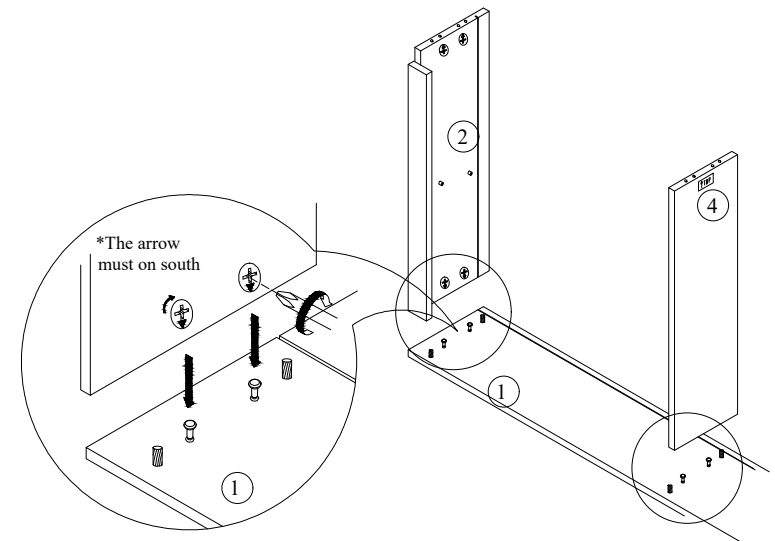

Please do not tighten an the hardware until the entire assembly is completed

# ASSEMBLY INSTRUCTION

STEP 5  
(SECTION A)

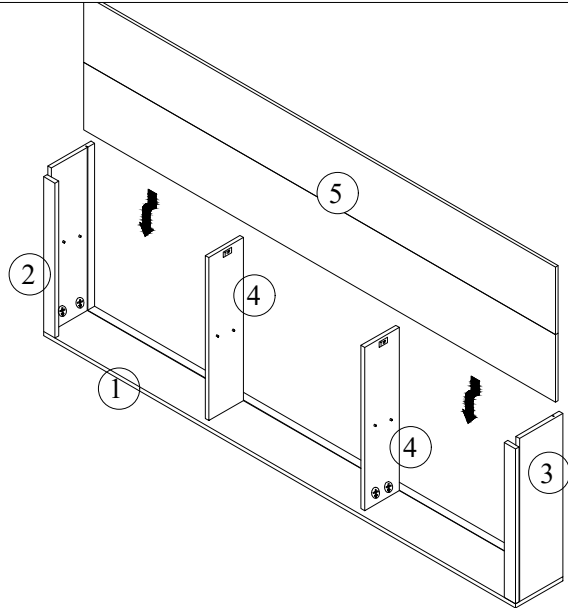

STEP 6

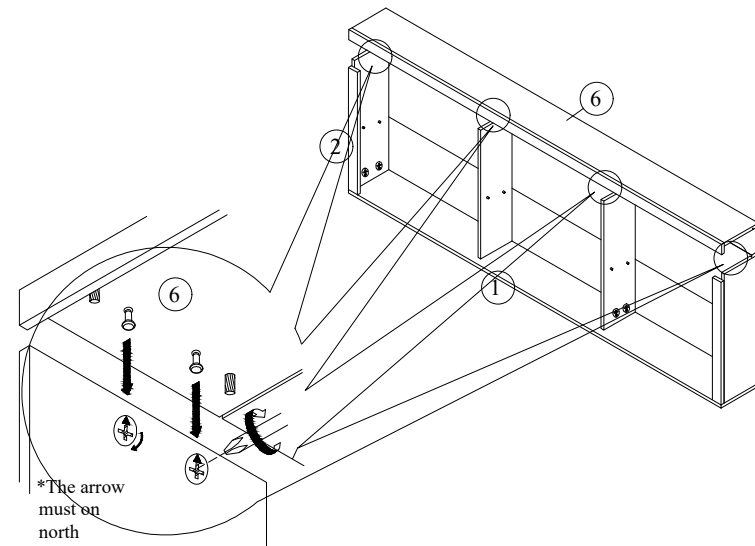

STEP 7

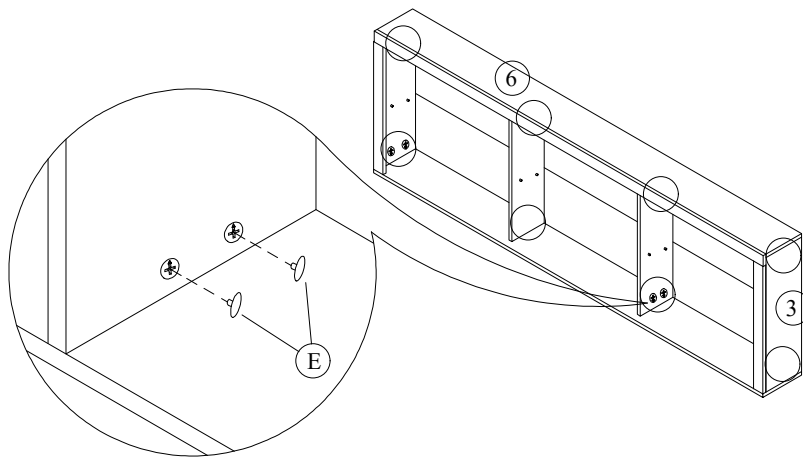

STEP 8

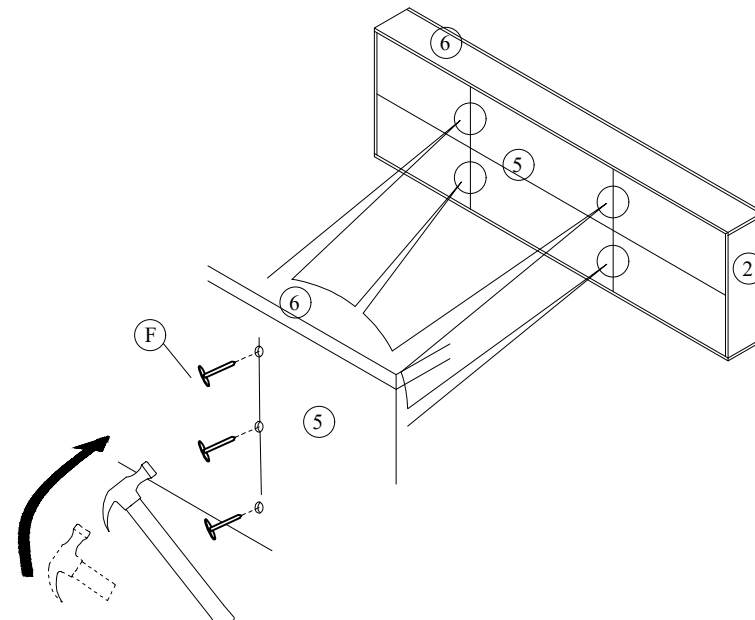

Please do not tighten an the hardware until the entire assembly is completed.

# ASSEMBLY INSTRUCTION

STEP 1  
(SECTION A)

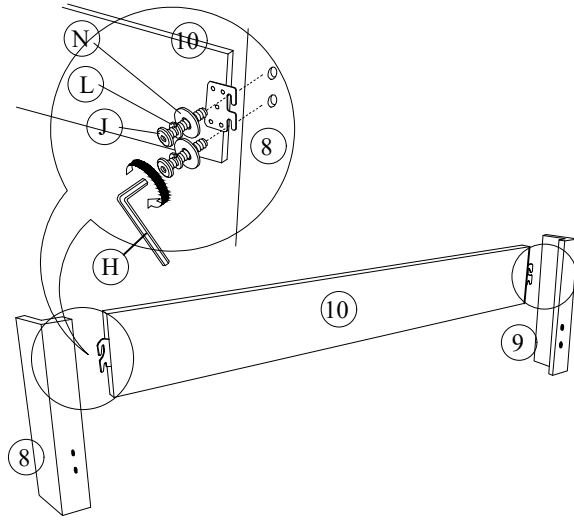

STEP 2

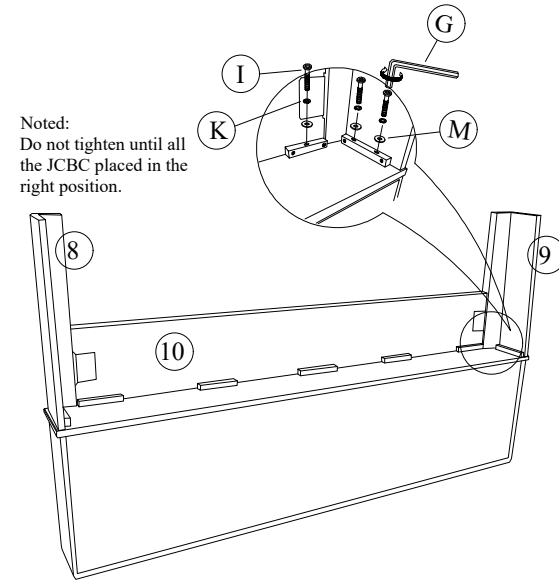

STEP 3

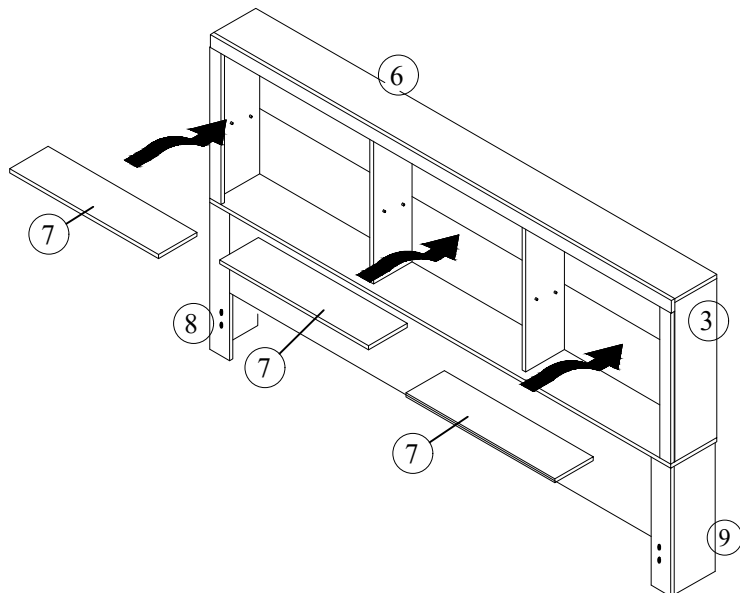

STEP 4

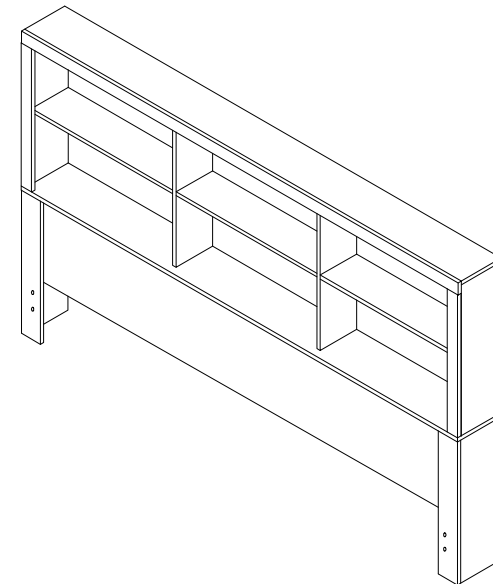





Please do not tighten on the hardware until the entire assembly is completed





CONTINUE TO  
SECTION C

PAGE 03 OF 05

# ASSEMBLY INSTRUCTION

NO.	PART LIST	QTY
11	 SIDE RAIL	2PCS
12	 FOOTBOARD	1PC
13	 SLAT	1SET
21	 CENTER SUPPORT	1PC
22	 SUPPORT LEG	3PCS

(SECTION C)

ITEM	HARDWARE	QTY
A	 SCREW M4 x 32mm	6PCS
B	 L-KEY M4 x 65mm	1PC
C	 L-KEY M5 x 65mm	1PC
D	 JCBB SCREW M8 x 16mm	8PCS
E	 JCBB SCREW M6 x 50mm	3PCS

STEP 1  
(SECTION C)

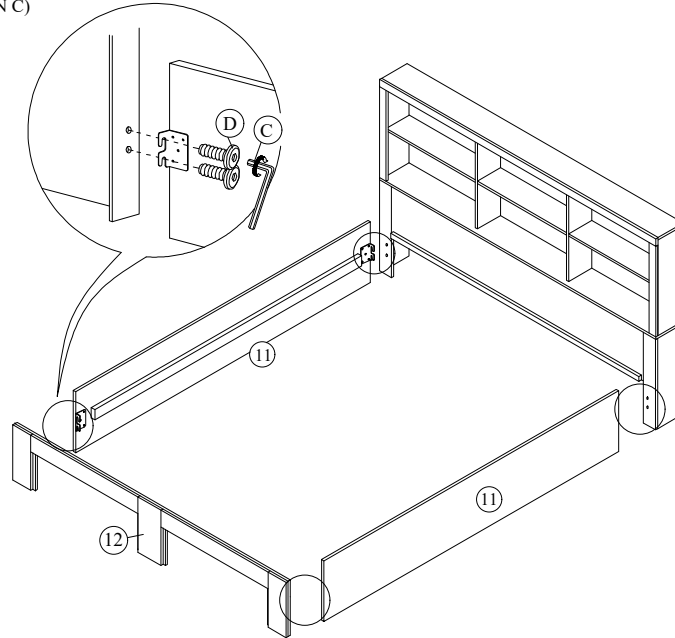

STEP 2

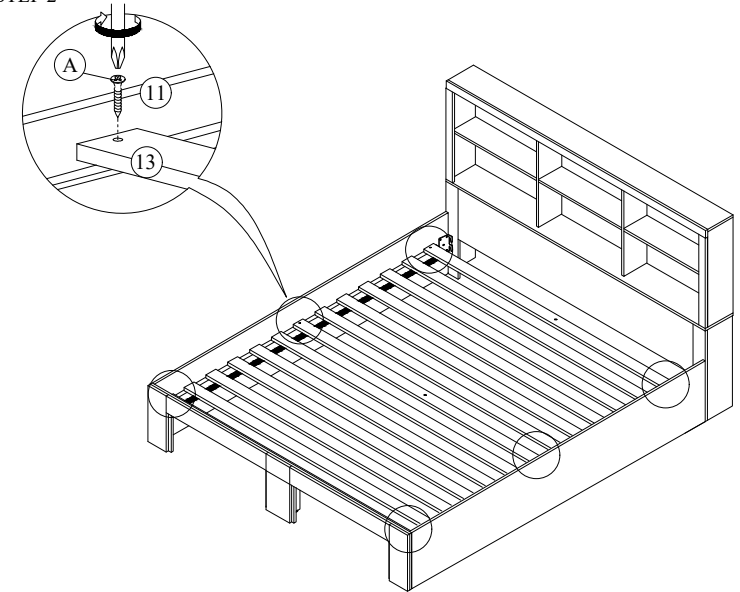

STEP 3

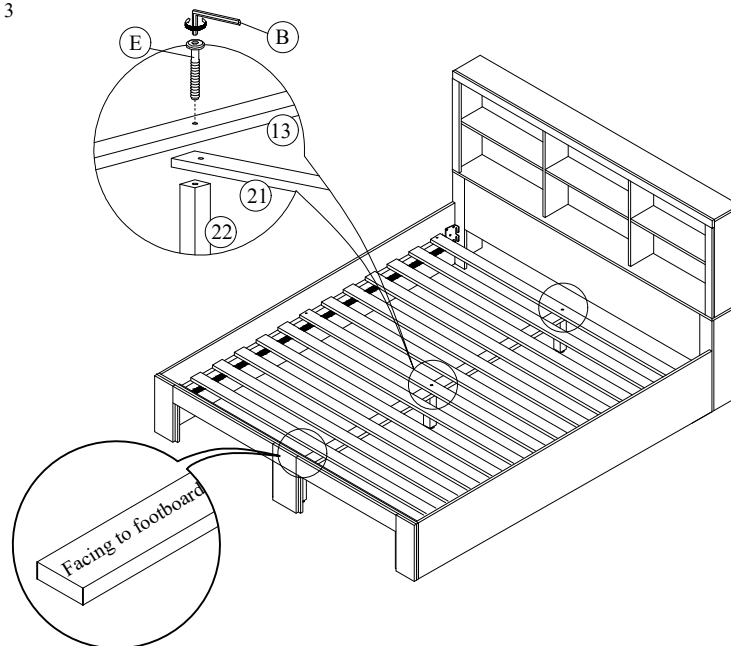

STEP 4

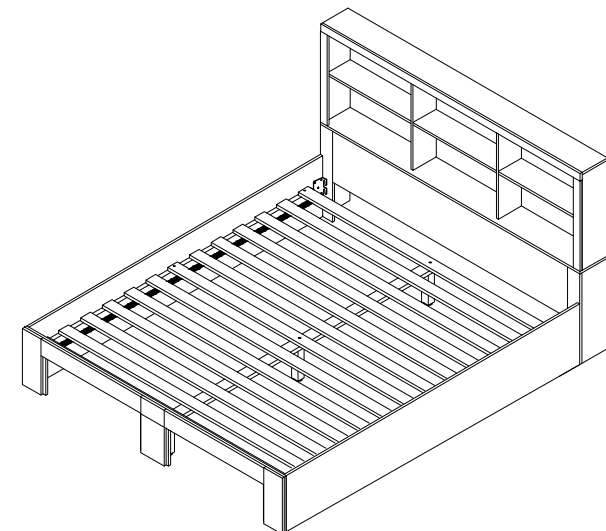

Please do not tighten the hardware until the entire assembly is completed

CONTINUE TO  
SECTION D

PAGE 04 OF 05

# ASSEMBLY INSTRUCTION

NO.	PART LIST	QTY
14	DRAWER FRON	2PCS
15	DRAWER BACK	2PCS
16	DRAWER SIDE	2PCS
17	DRAWER SIDE	2PCS
18	BOTTOM PANEL	2PCS
19	RAIL	4PCS
20	CASTER	8PCS

STEP 1  
(SECTION D)

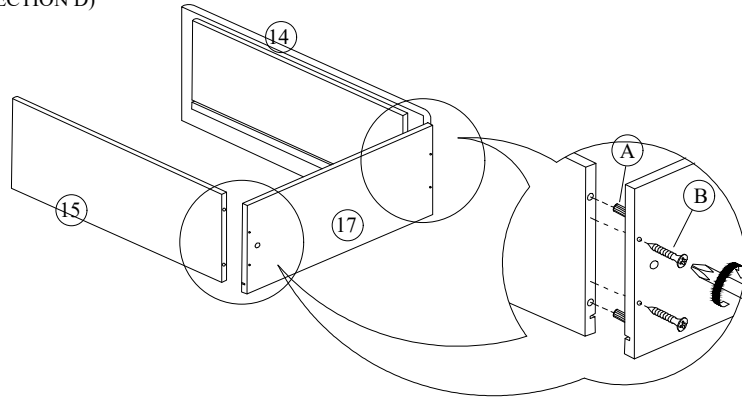

STEP 2

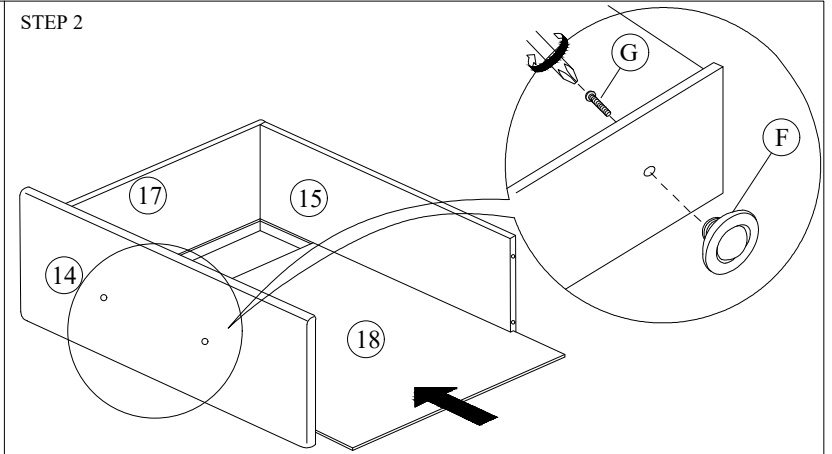

STEP 3

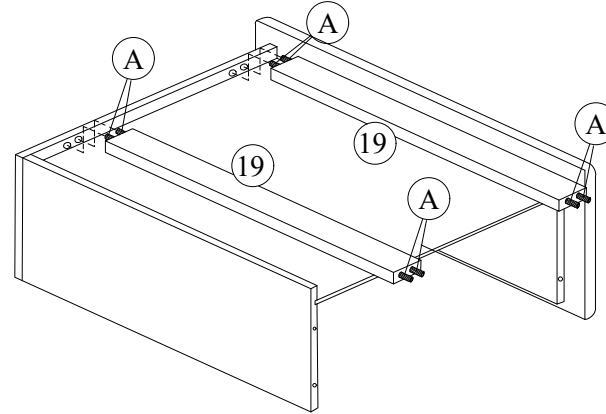

STEP 4

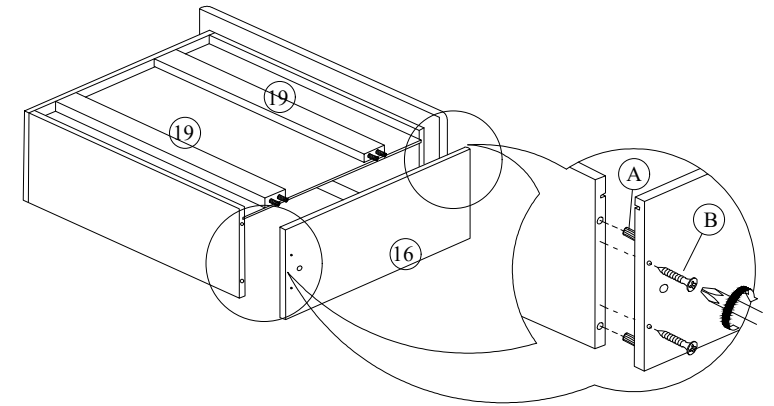

(SECTION D)

ITEM	HARDWARE	QTY
A	WOOD DOWEL	32PCS
B	SCREW M4 x 32mm	16PCS
C	SCREW M4 x 16mm	32PCS
D	SCREW M6 x 35mm	4PCS
E	L-KEY M4 x 65mm	1PC
F	HANDLE	4PCS
G	HANDLE BOLT M4 x 38mm	4PCS

STEP 5

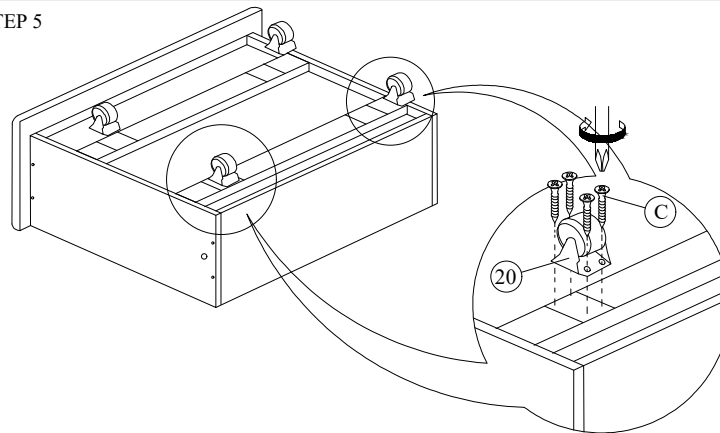

STEP 6

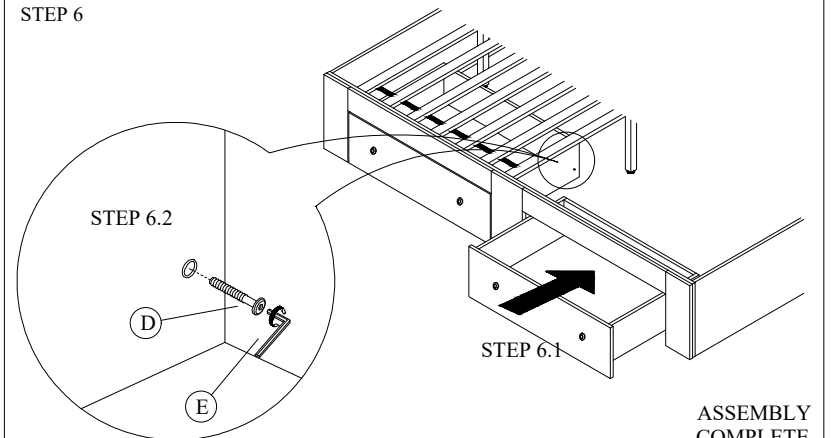

Please do not tighten on the hardware until the entire assembly is completed.

ASSEMBLY  
COMPLETE