

Installation & Assembly

Version:1.0

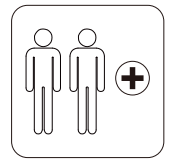
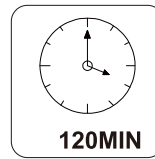
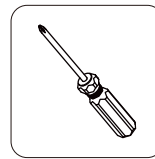
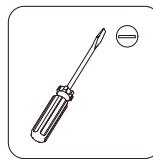
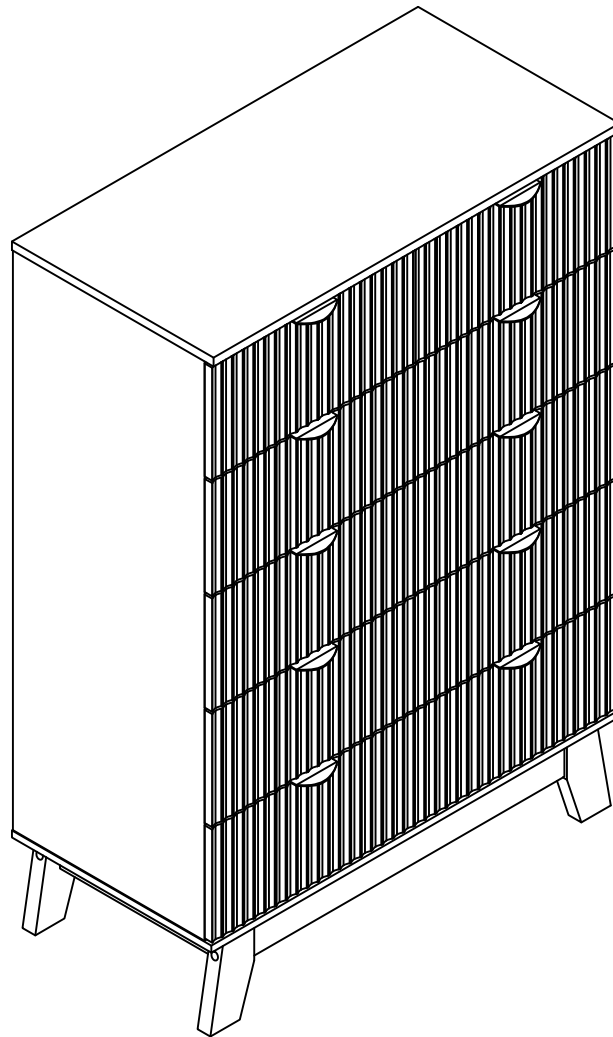

EN_IMPORTANT, RETAIN FOR FUTURE REFERENCE: READ CAREFULLY.

USING CAM LOCK AND QUICKFIT

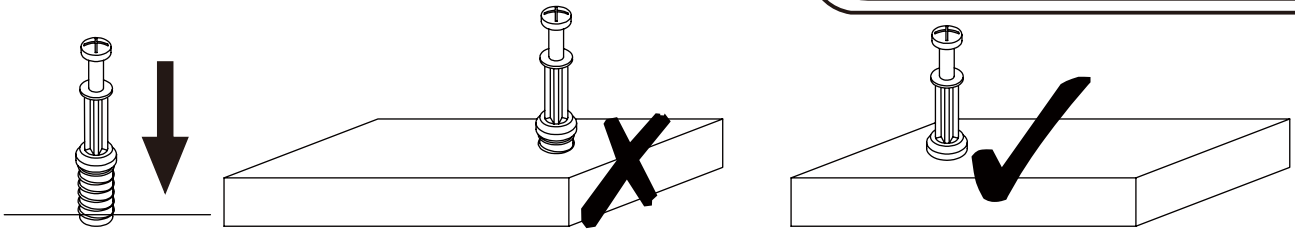

EN_QUICKFIT: Tighten quickfit until shoulder is flush with panel. Do not overtighten or undertighten.

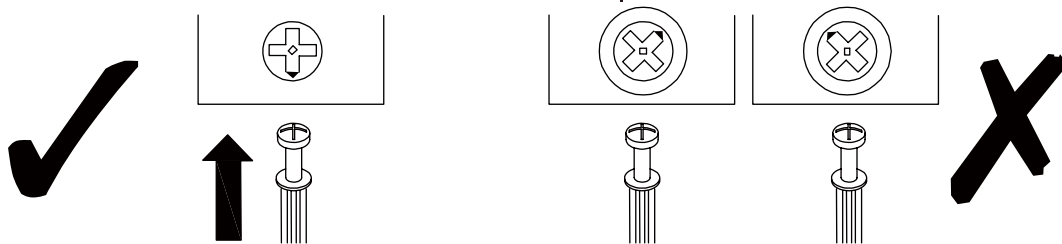

EN_CAM LOCK: When fitting cam lock, ensure starting position is correct before you insert connecting quickfit.

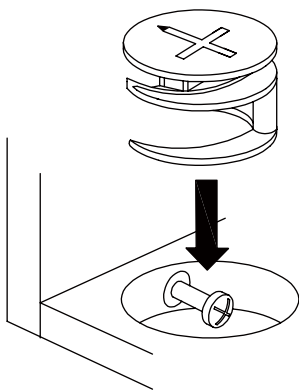

EN_Quickfit head should be in the centre of the cam lock when the two panels are joined.
Cam lock should be inserted before quickfit.

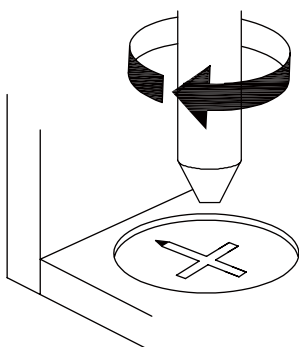



EN_Turn cam lock clockwise to tighten.

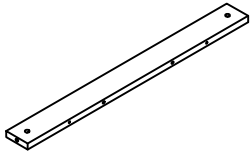
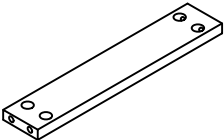
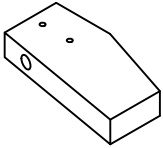
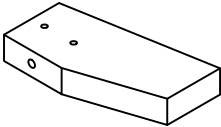
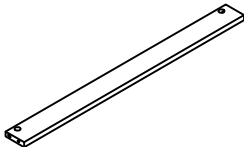
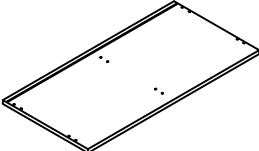
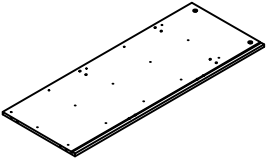
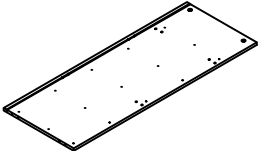
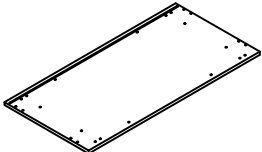
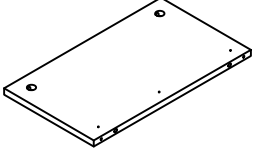

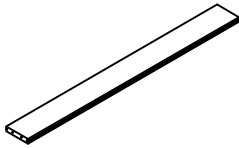
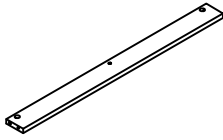
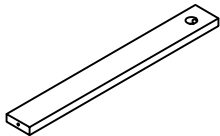
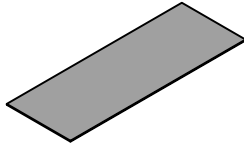
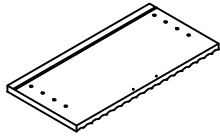
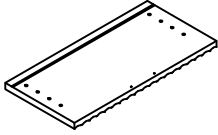
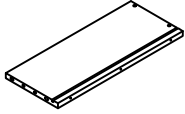
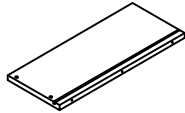
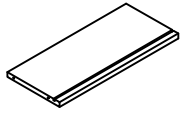
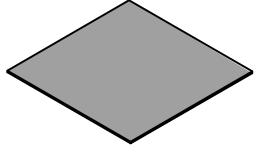

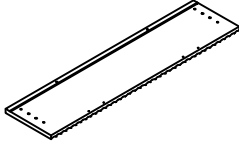
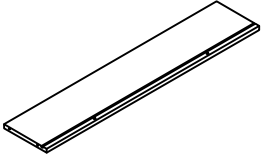
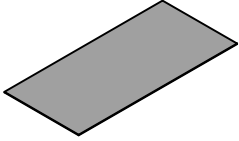



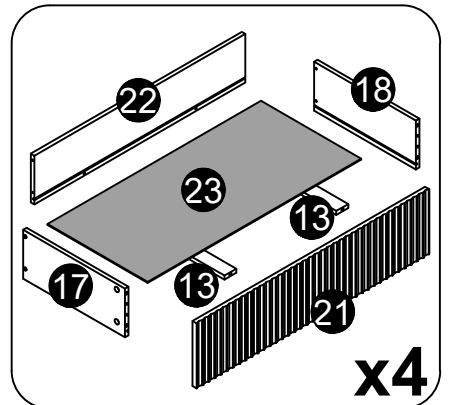
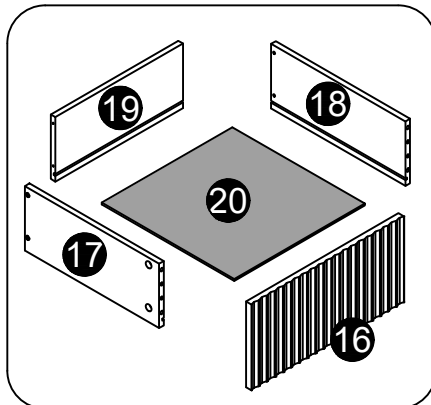
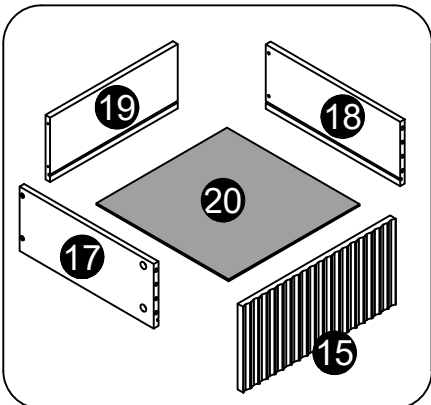
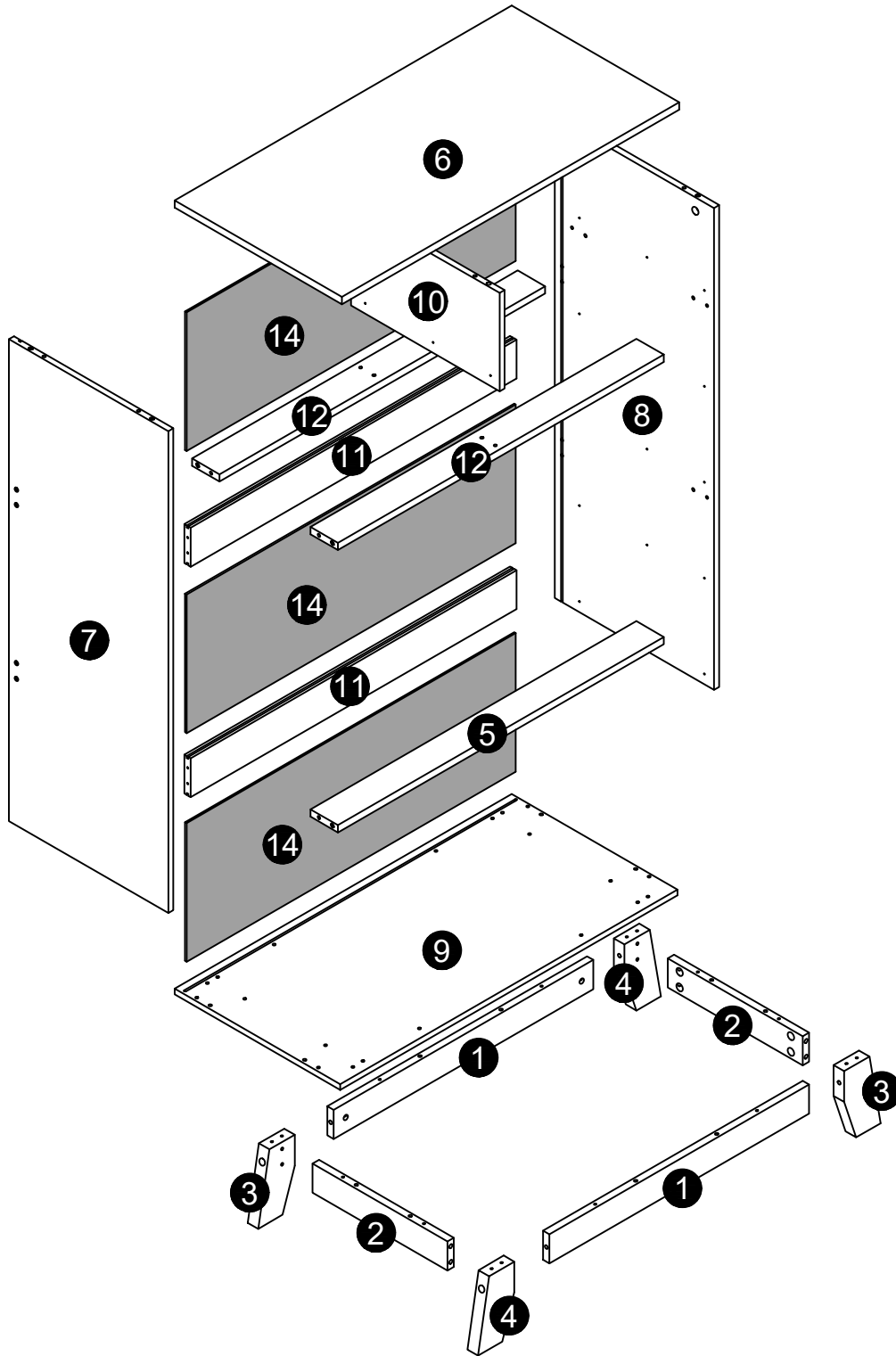

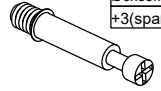

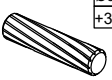
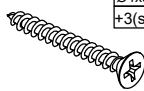

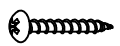

PACKING DELALS

NO.	PARTS	QTY	SPARE
①		x2	
②		x2	
③		x2	
④		x2	
⑤		x1	
⑥		x1	
⑦		x1	
⑧		x1	
⑨		x1	
⑩		x1	

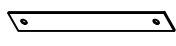

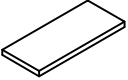

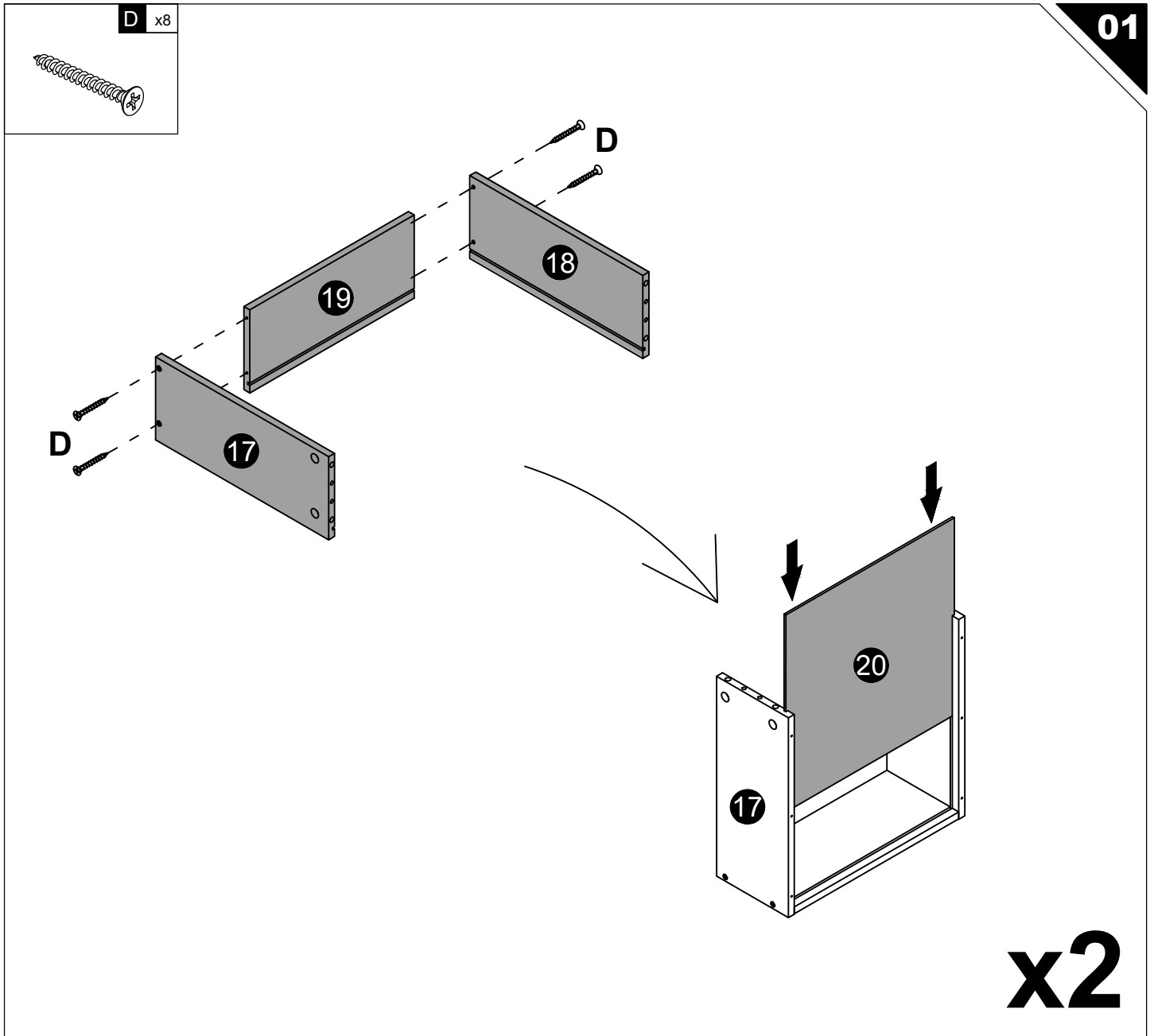

NO.		QTY	SPARE
⑪		x2	
⑫		x2	
⑬		x8	
⑭		x3	
⑮		x1	
⑯		x1	
⑰		x6	
⑱		x6	
⑲		x2	
⑳		x2	

NO.	PARTS	QTY	SPARE
②1		x4	
②2		x4	
②3		x4	
	 Hardware Kit	x1	

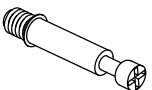

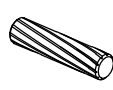
<p>A x52 Ø6x35mm +3(spare)</p> 	<p>B x52 Ø15x10mm +3(spare)</p> 	<p>C x50 Ø6x30mm +3(spare)</p> 	<p>D x48 Ø4x35mm +3(spare)</p> 	<p>E x92 Ø3.5x12mm +4(spare)</p> 	<p>F x10</p> 
<p>G x4</p> 	<p>H x4</p> 	<p>I x16 +1(spare)</p> 	<p>J x12 Ø3x16mm +1(spare)</p> 	<p>K x12 +1(spare)</p> 	<p>L x2 Ø6x30mm</p> 
<p>M x2</p> 	<p>N x2</p> 	<p>O x4</p> 			
<p>CL x6 L350mm</p> 	<p>CR x6 L350mm</p> 	<p>DL x6 L350mm</p> 	<p>DR x6 L350mm</p> 		

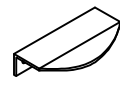

<p>A x8</p> 	<p>B x8</p> 	<p>C x8</p> 	<p>E x16</p> 	<p>F x2</p> 
<p>DL x2</p> 	<p>DR x2</p> 			

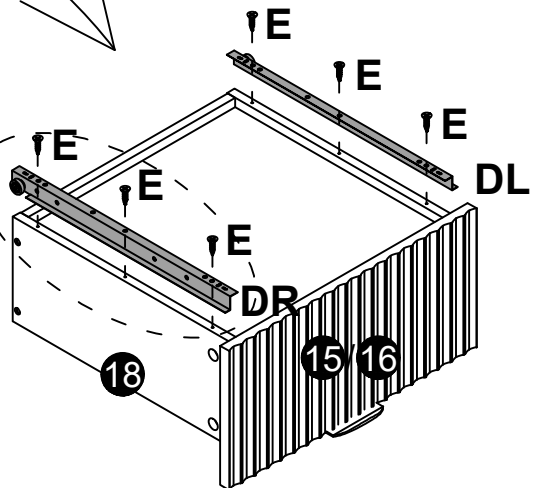
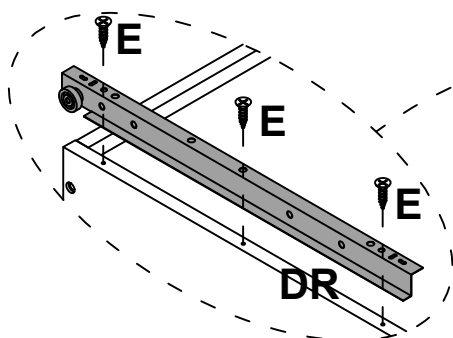
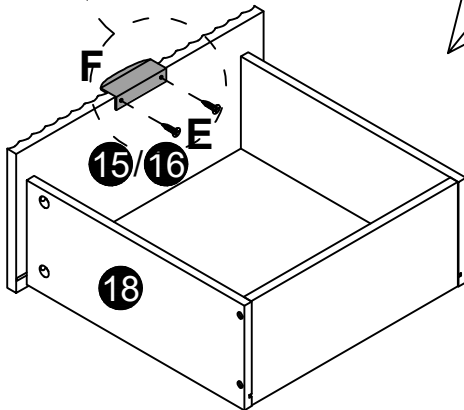
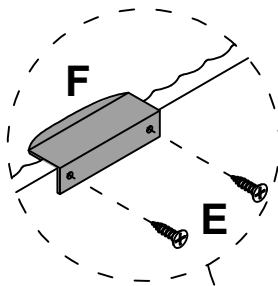
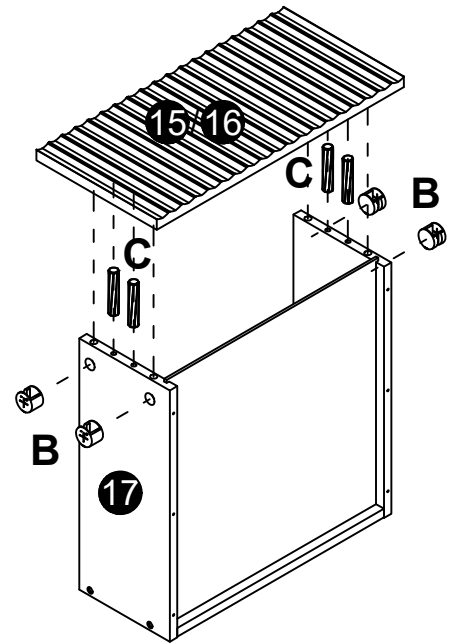
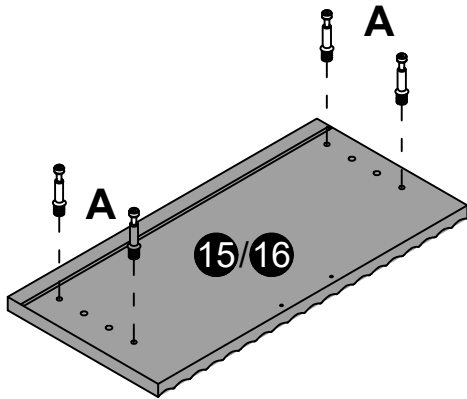

A x24

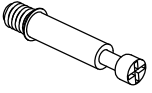

B x24



C x16



D x24

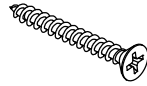

E x16



F x8

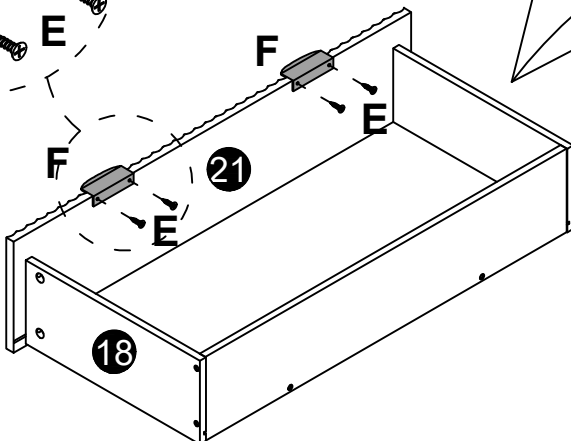
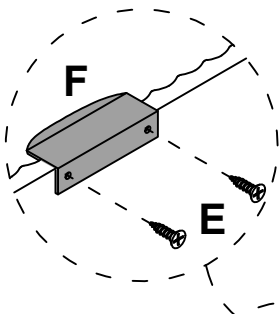
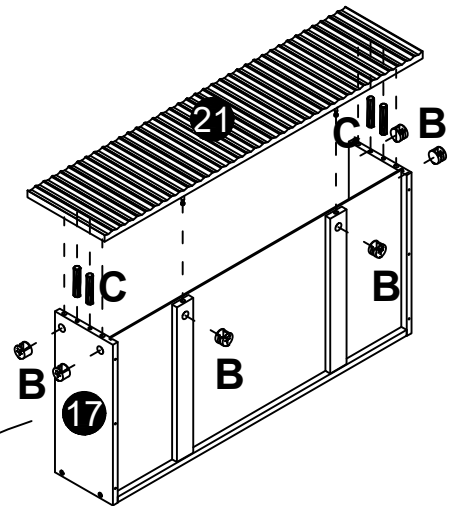
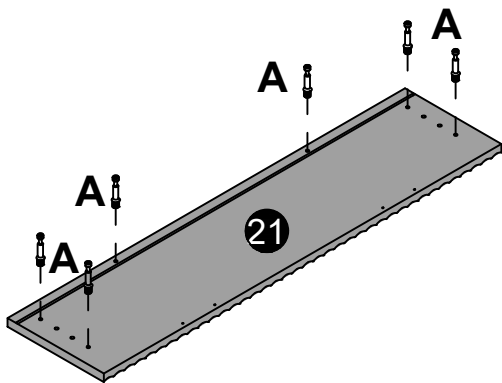
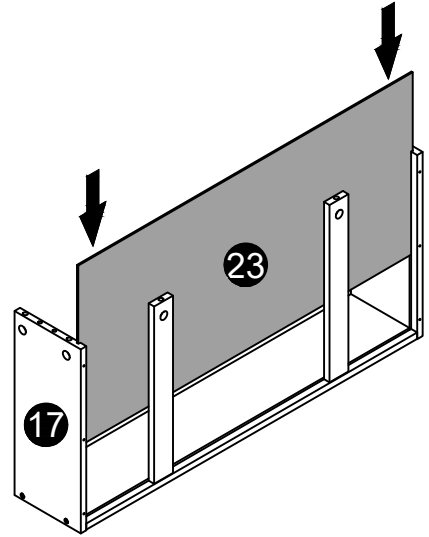
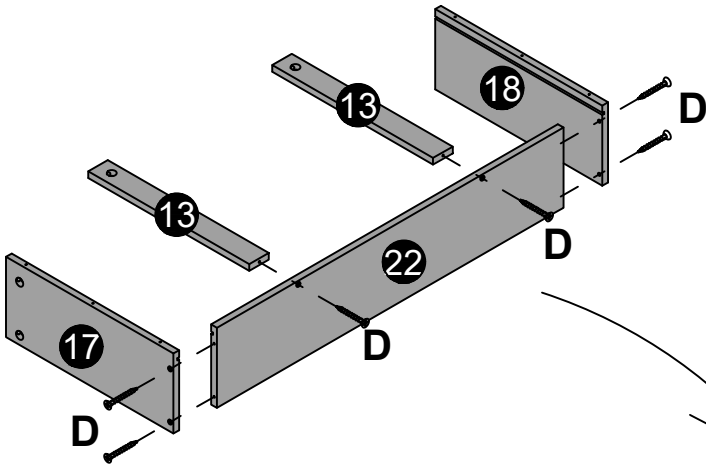

x4

E x24

DL x4

DR x4

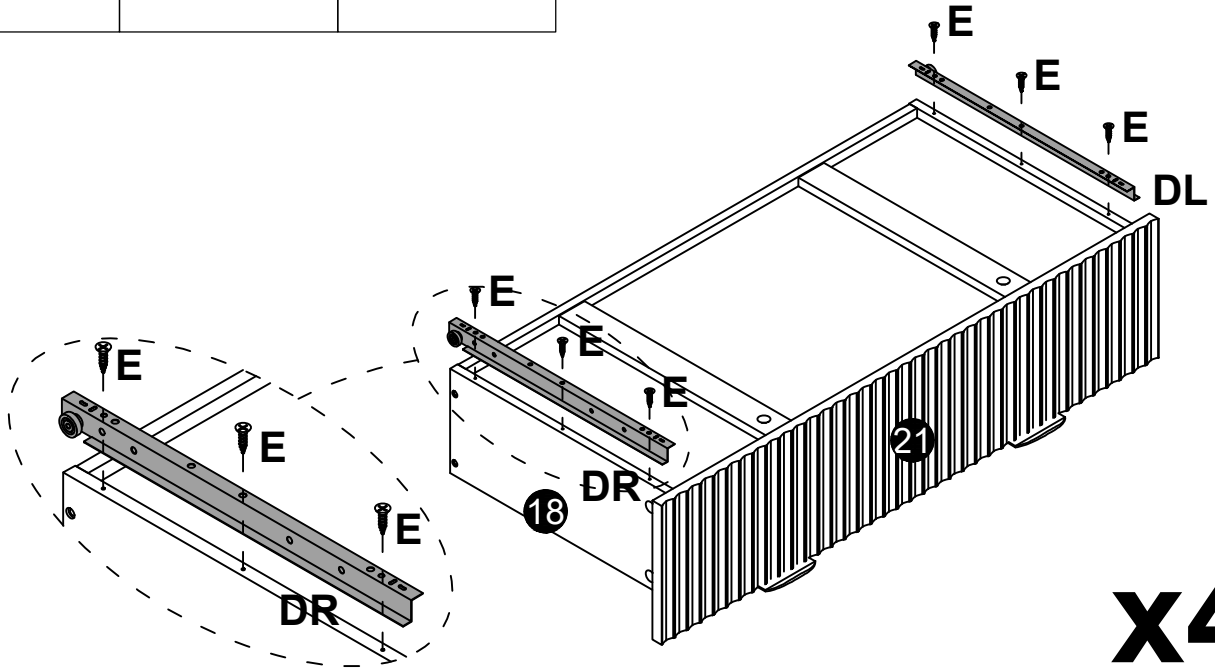

x4

A x3

E x15

CL x5

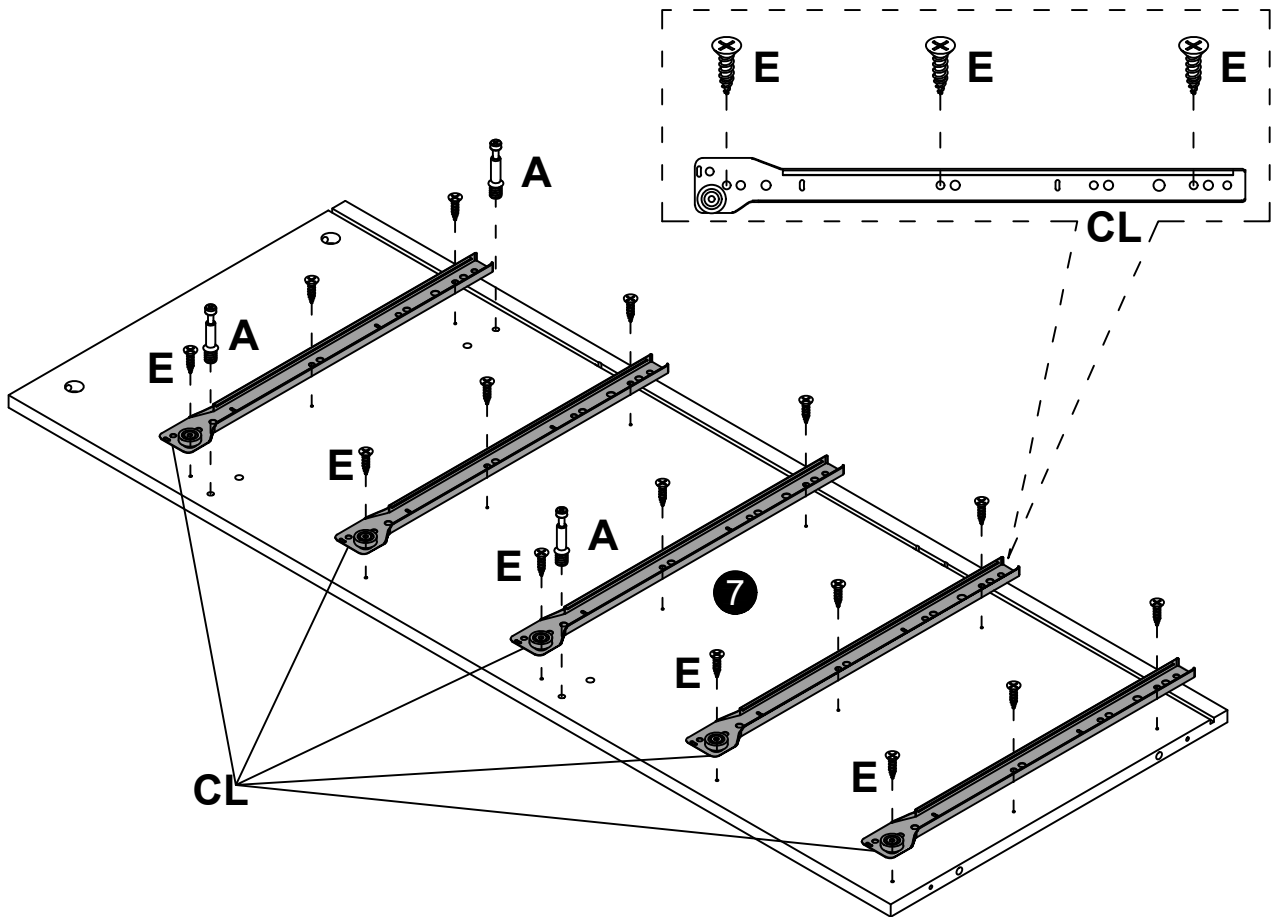
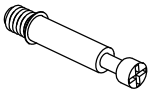

A x3

E x15

CR x5

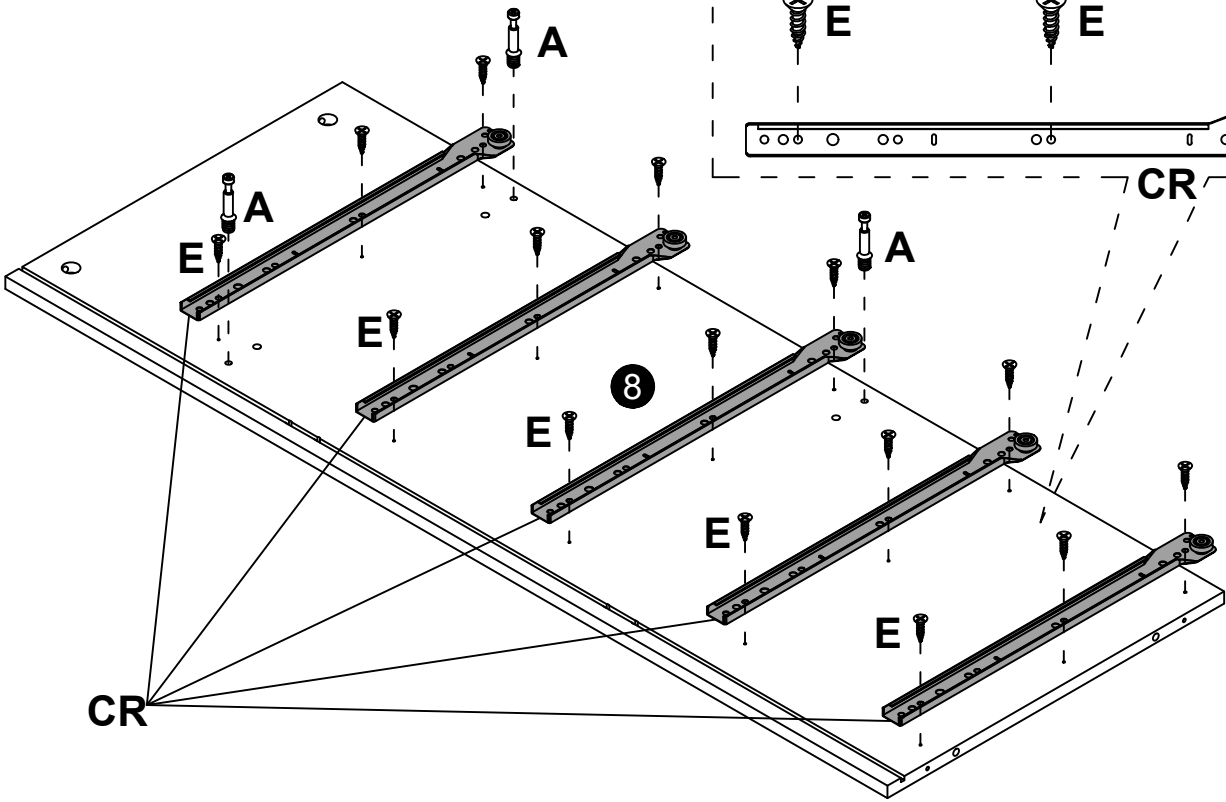
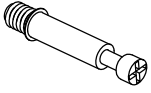

E x6

CL x1

CR x1

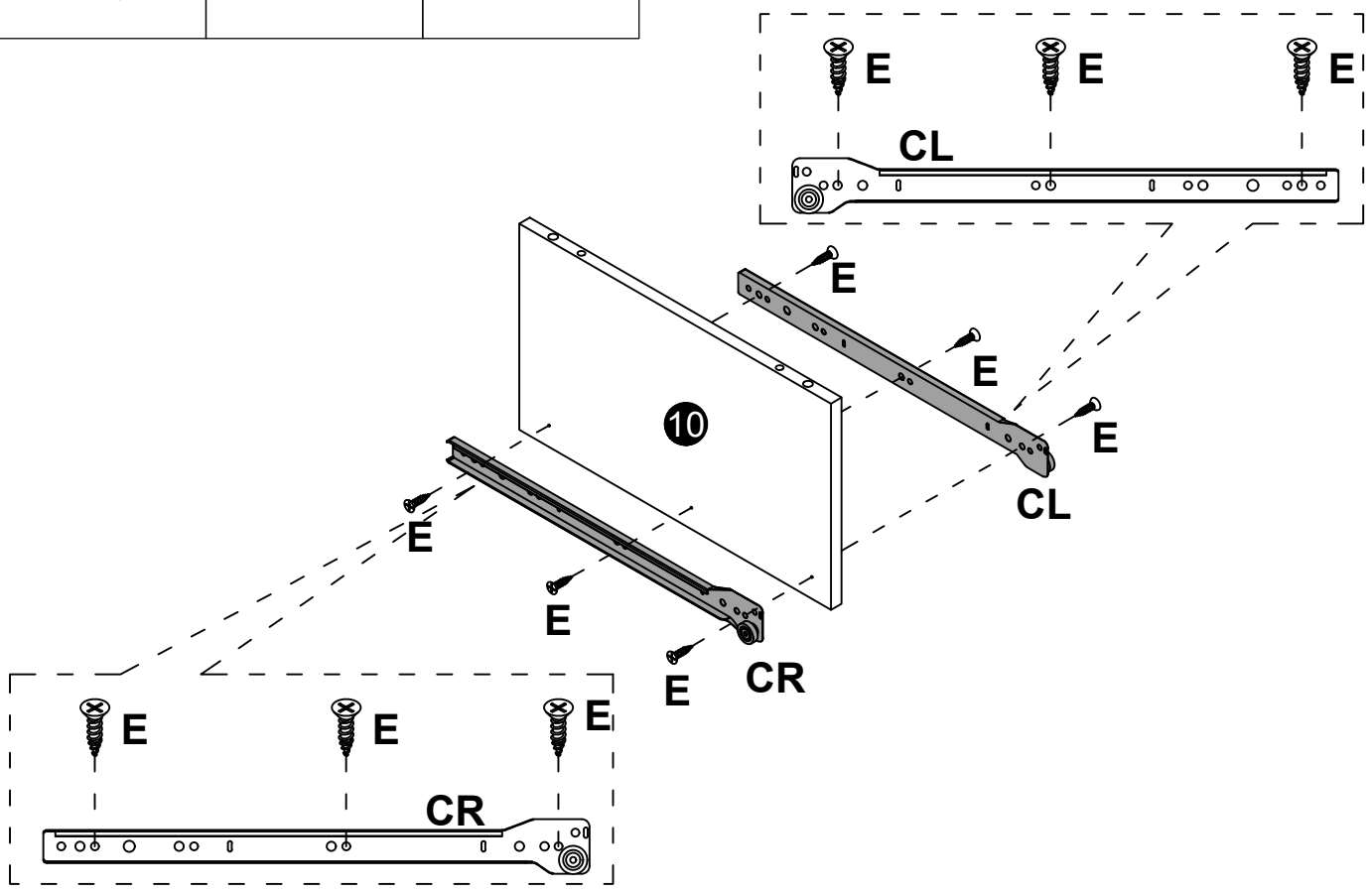

D x4

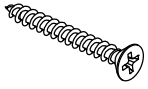

08

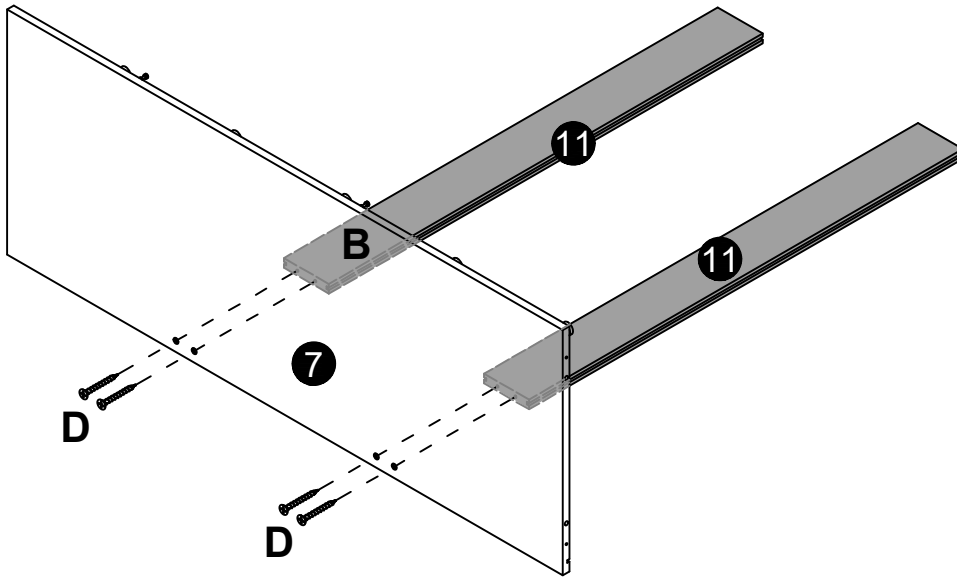

B x3



C x3



09

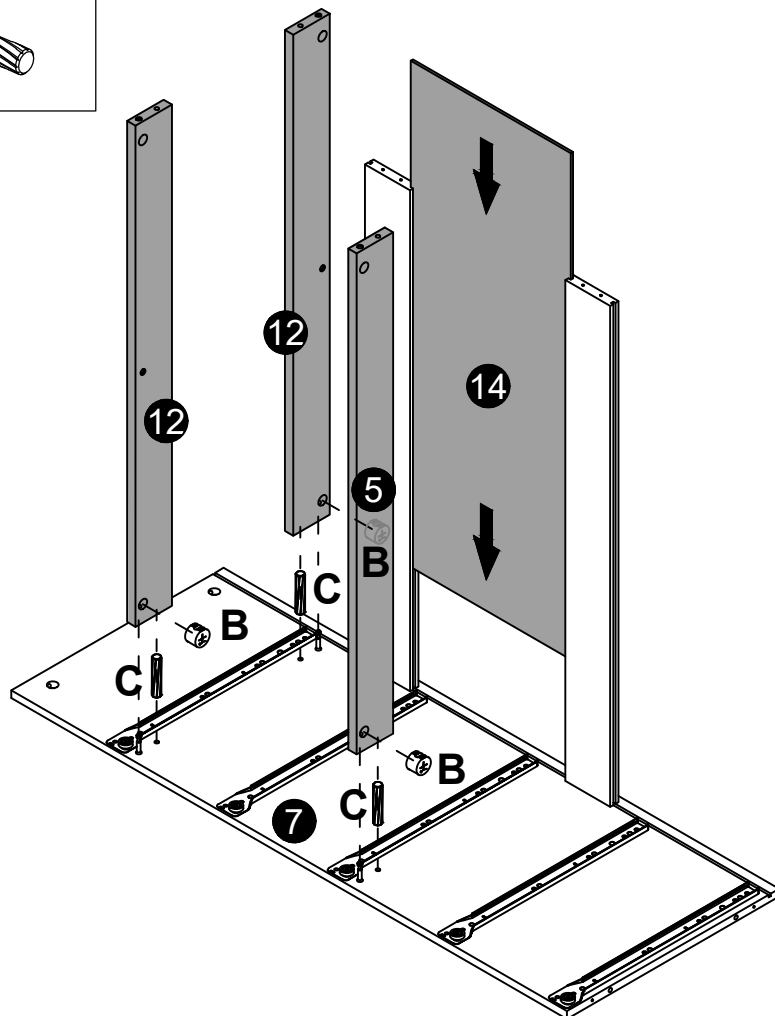

B x3

C x3

D x4

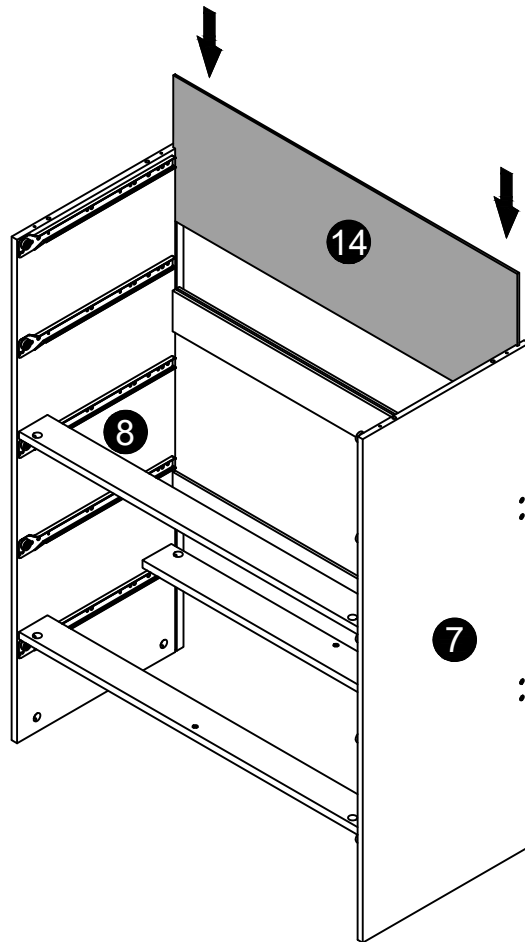
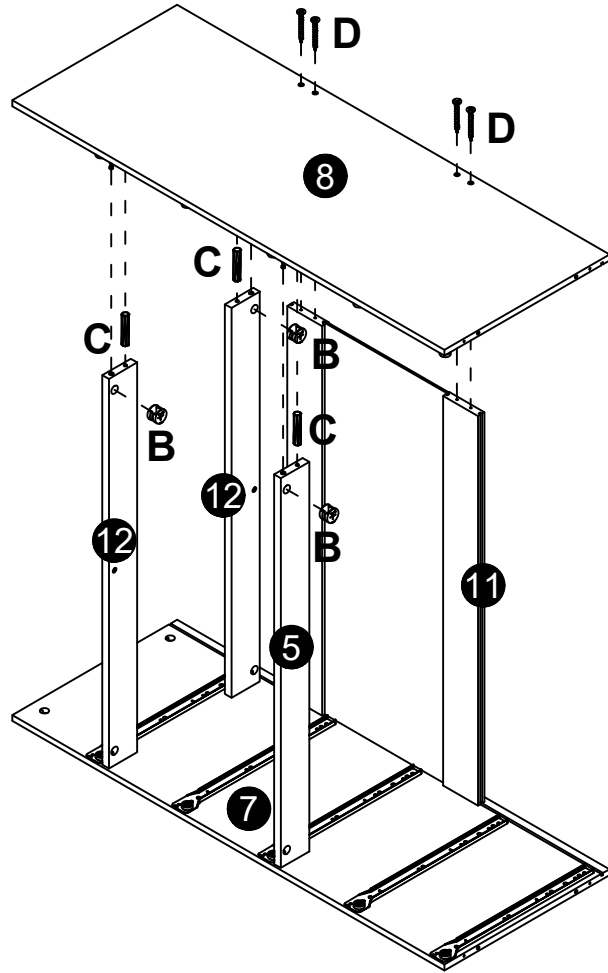
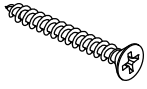

A x8

B x8

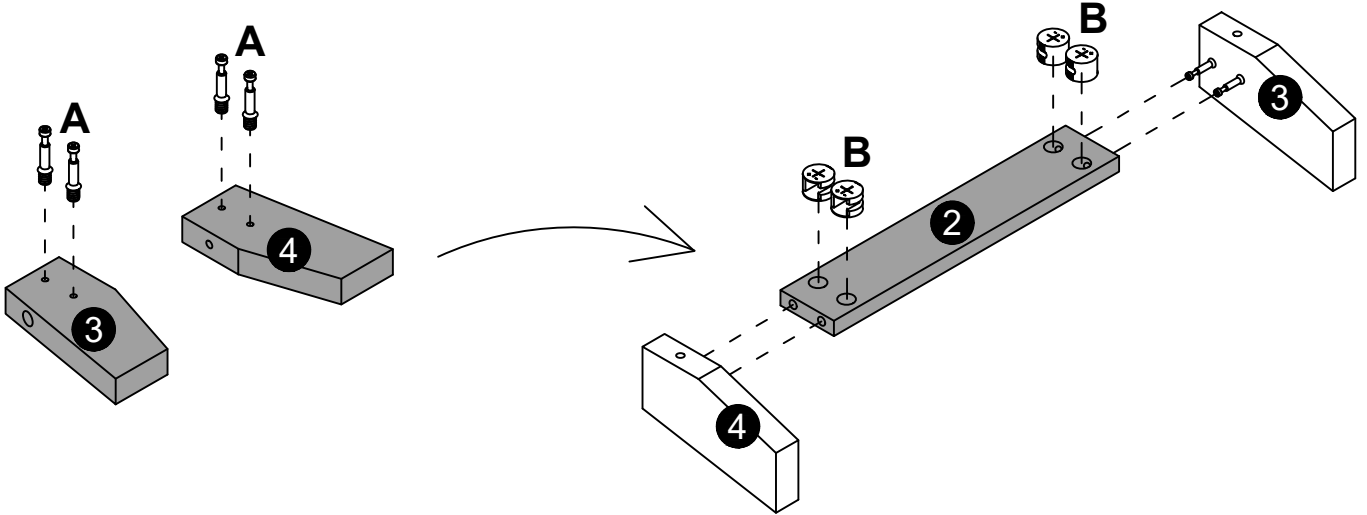
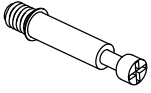

x2

G x4

H x4

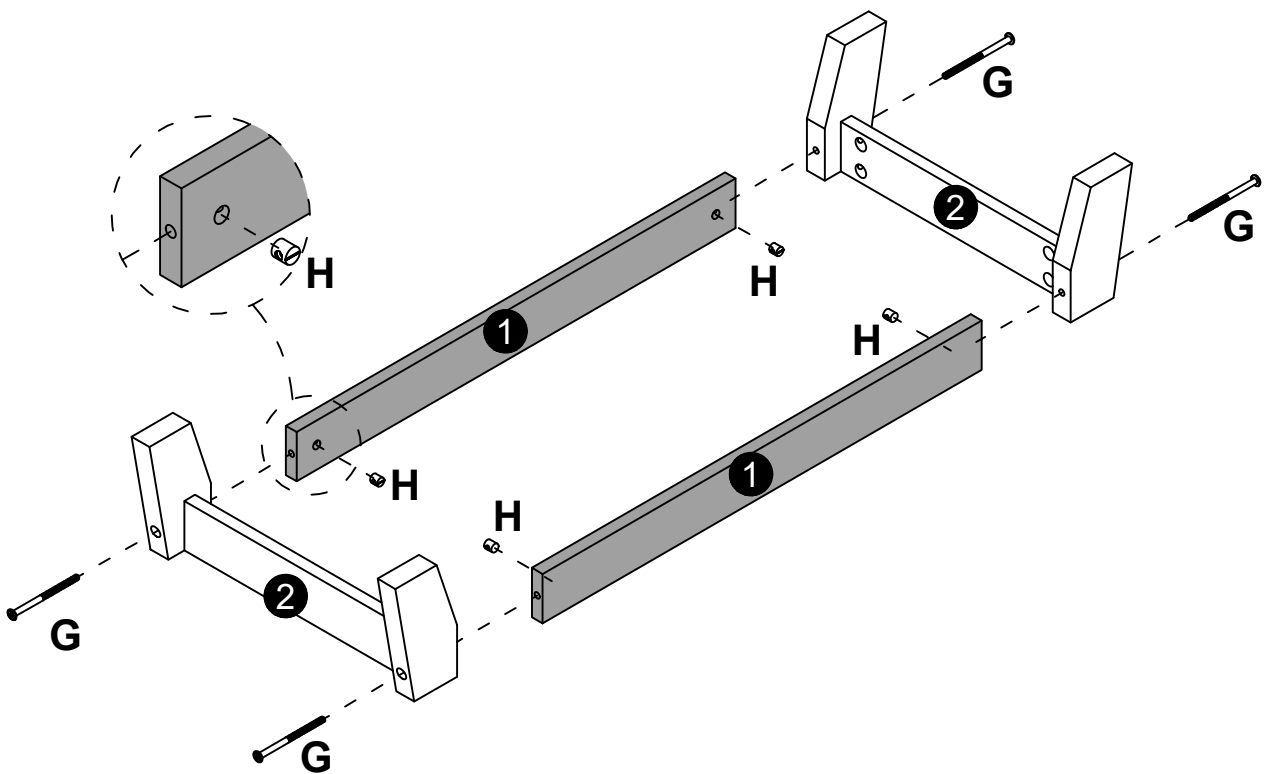

C x8

I x16

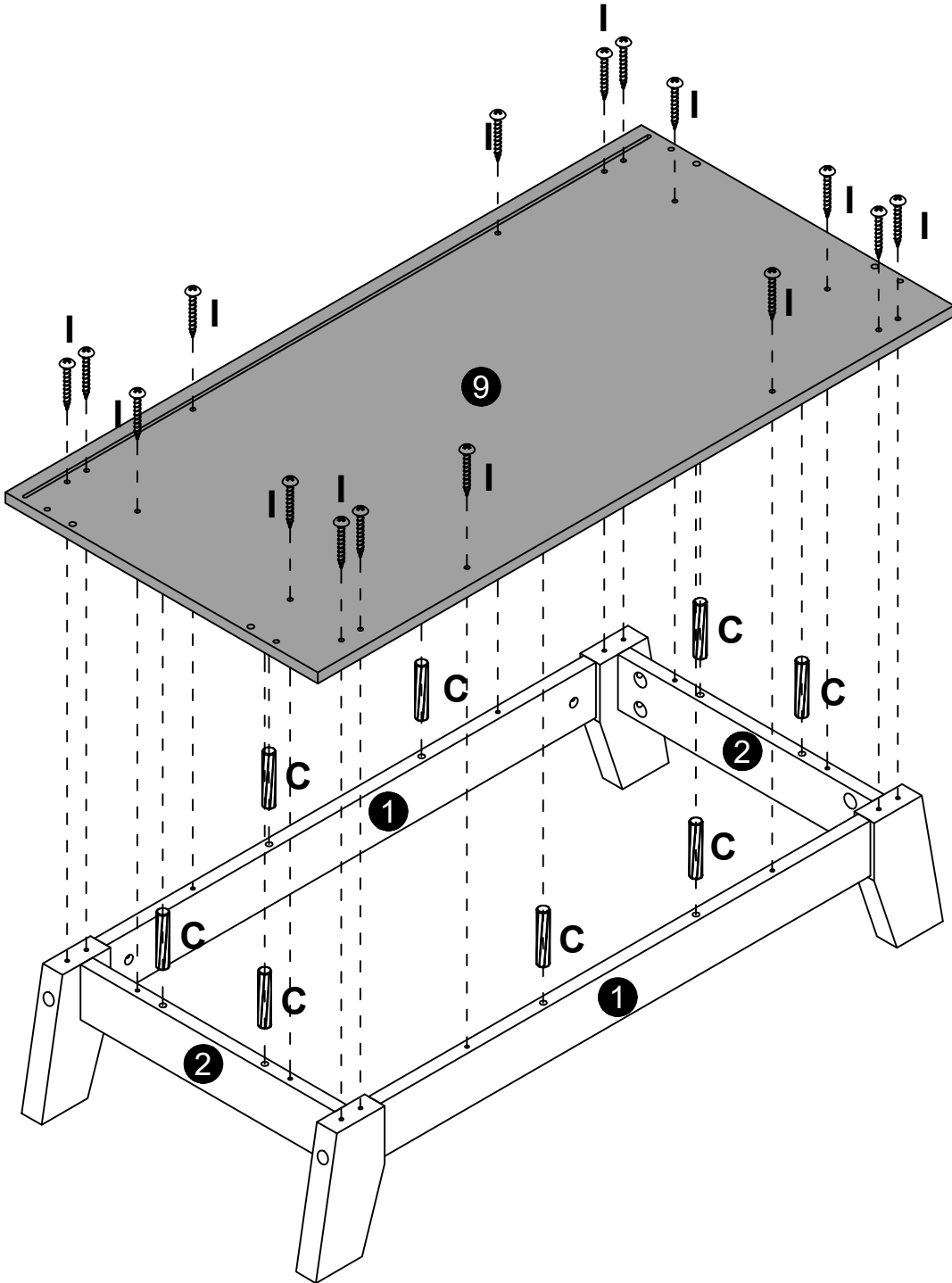
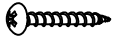
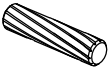

C x4

D x4

O x4

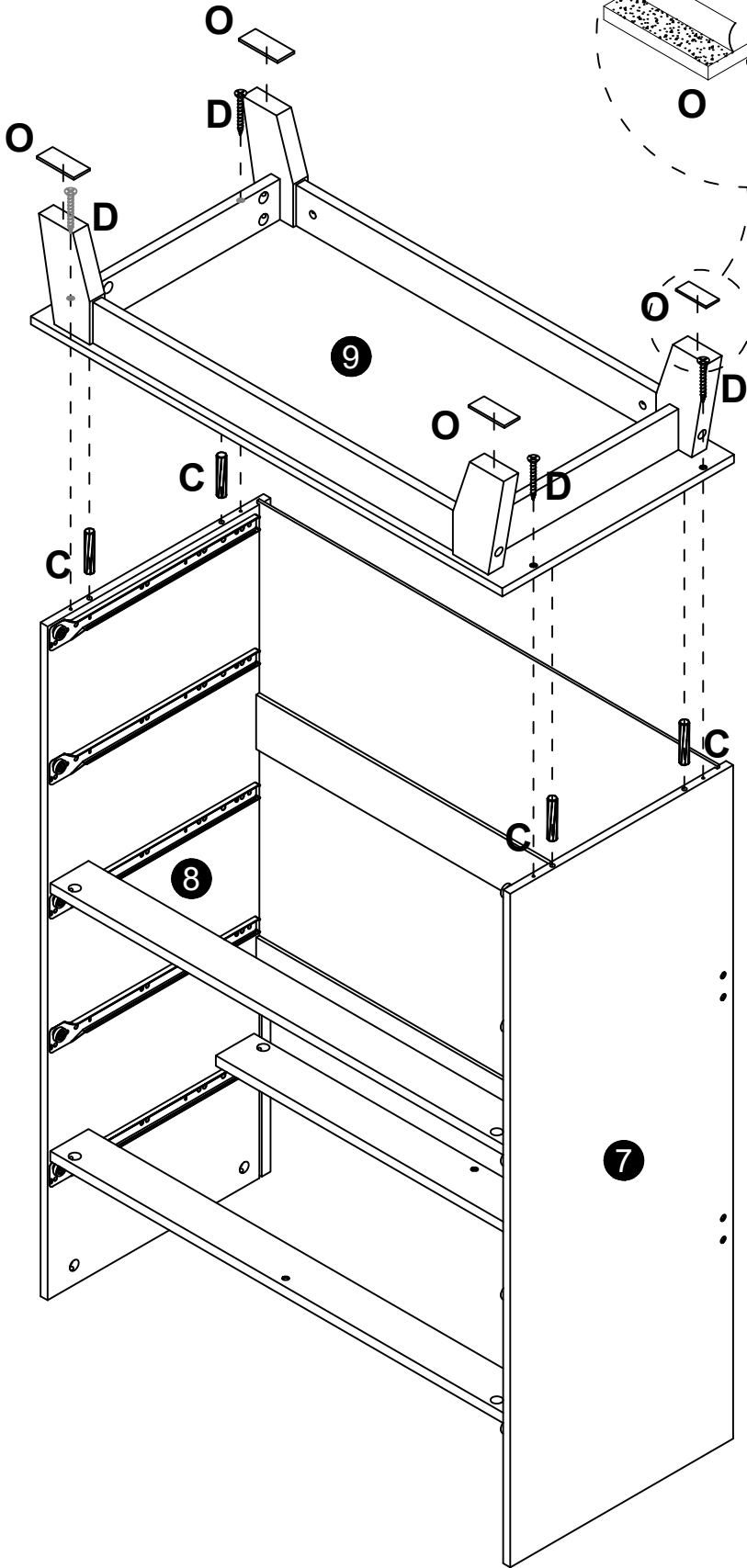
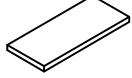
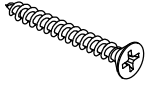
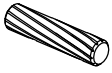

C x2

D x2

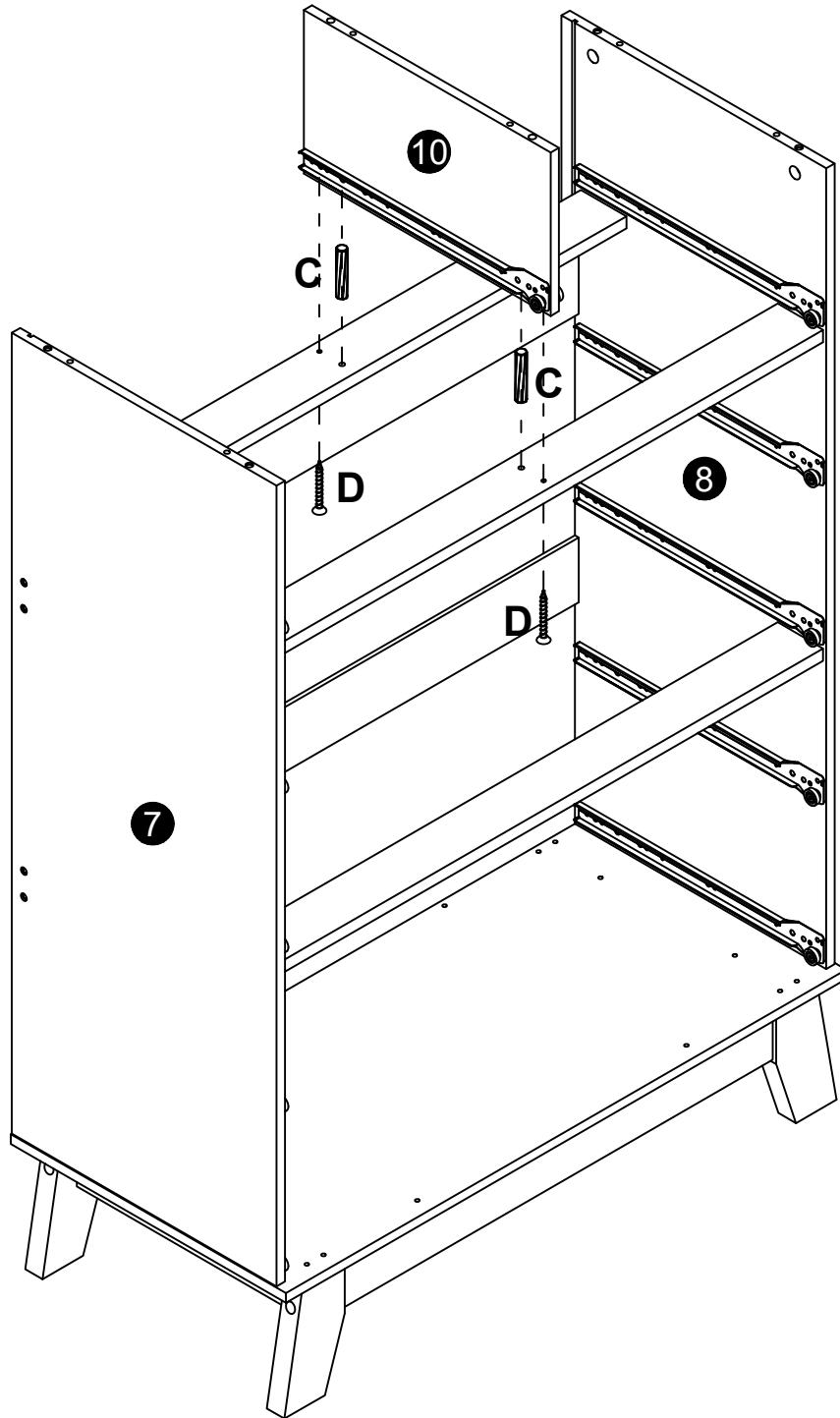
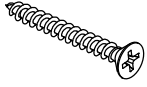
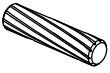

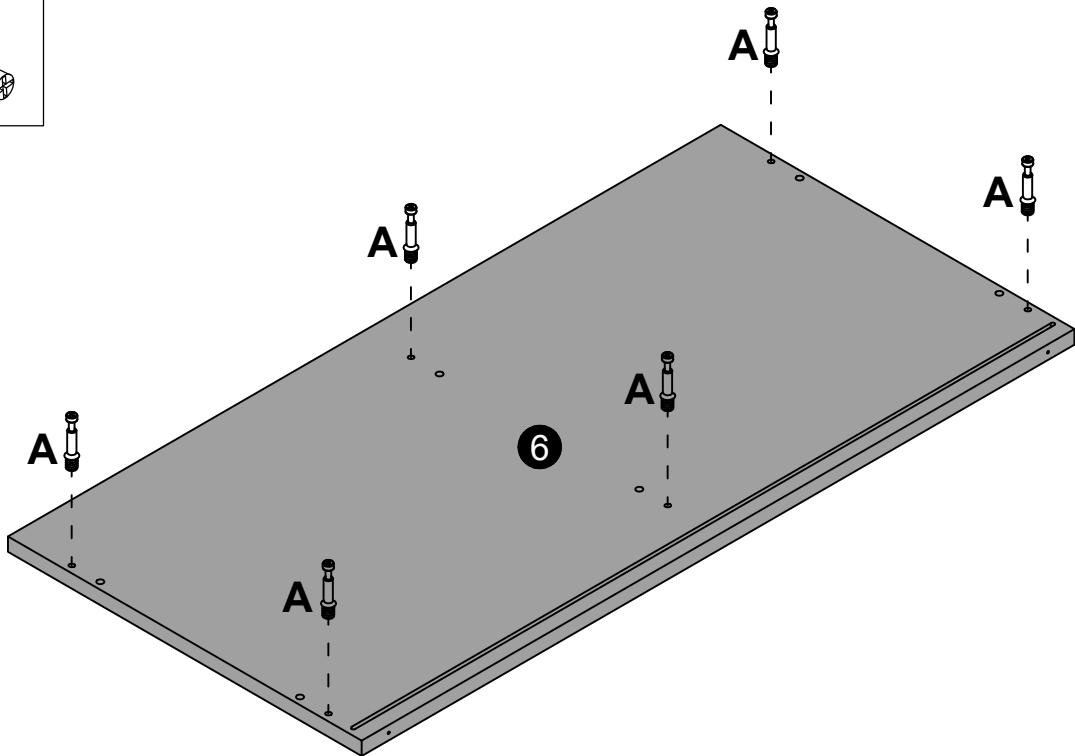
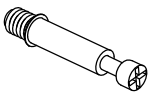
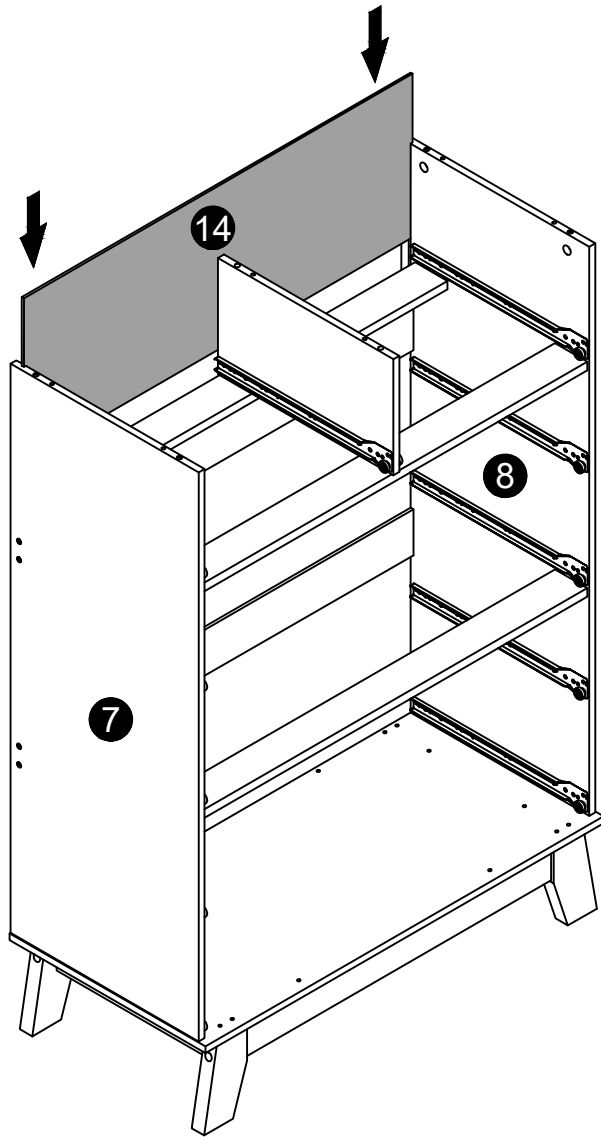

B x6

C x6

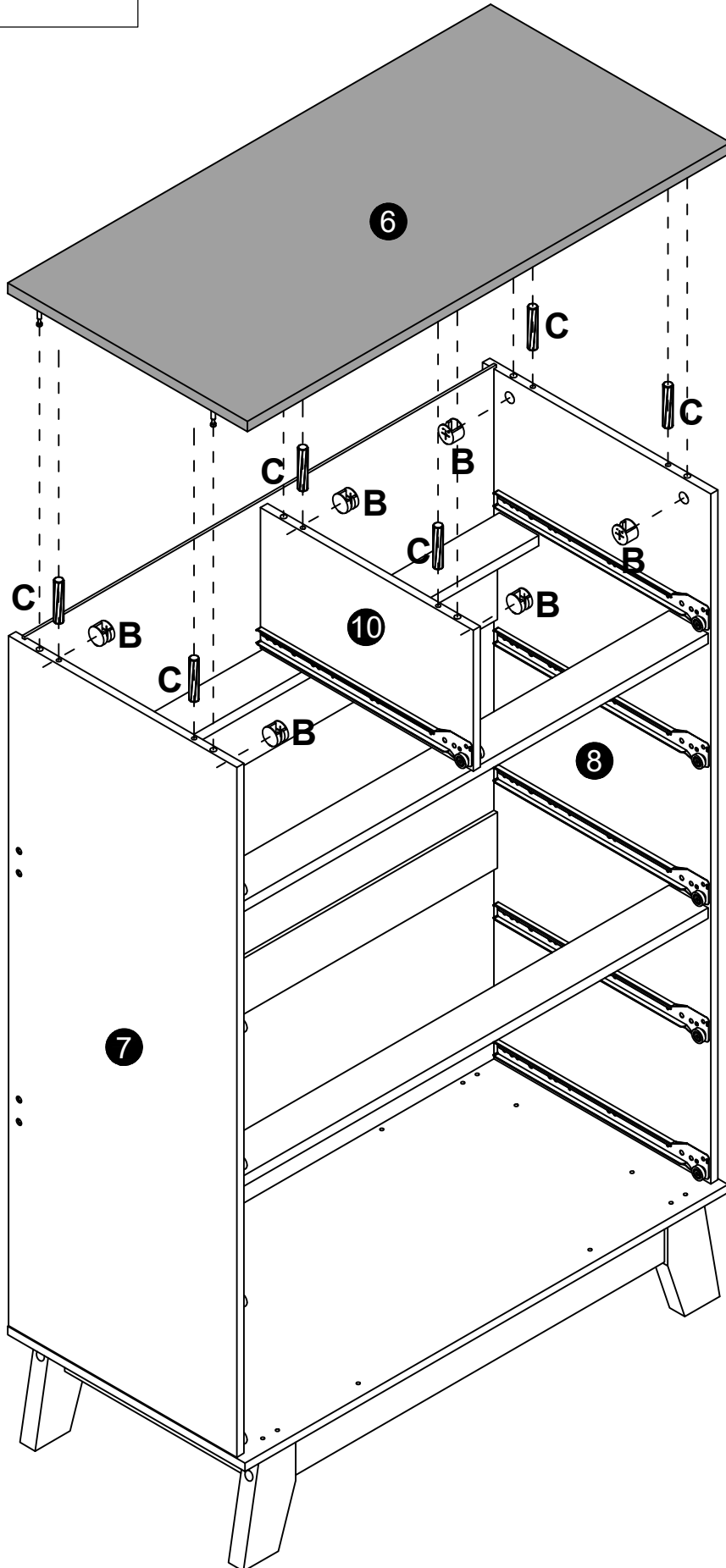

J x12

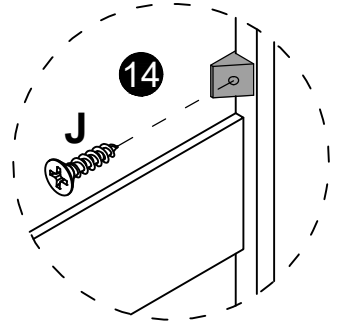
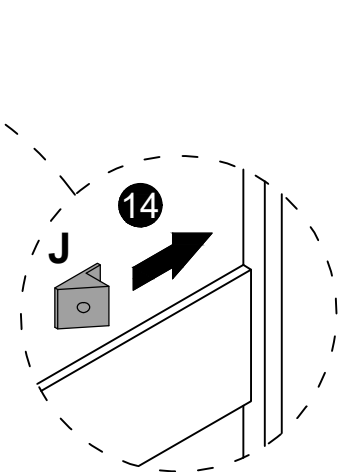
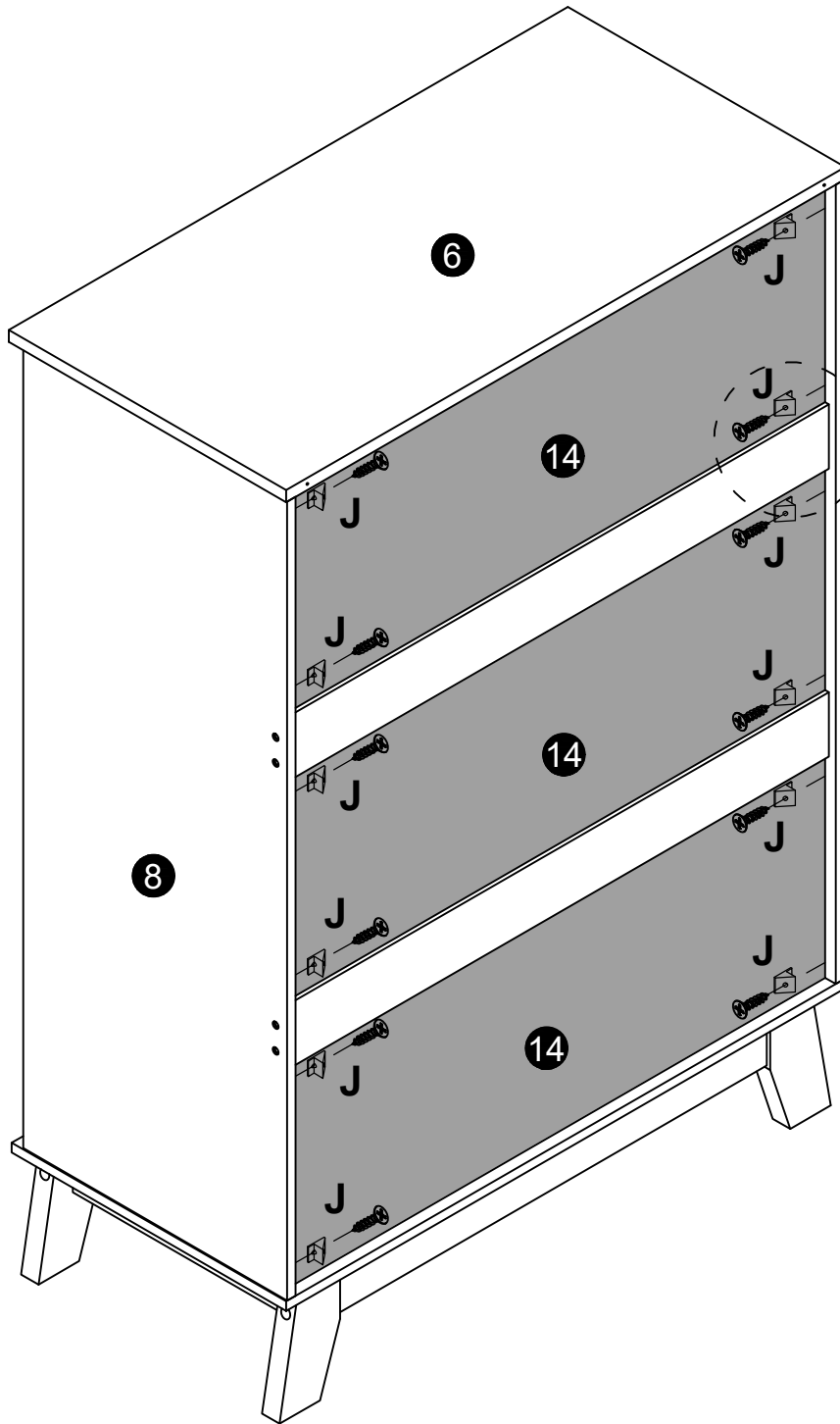

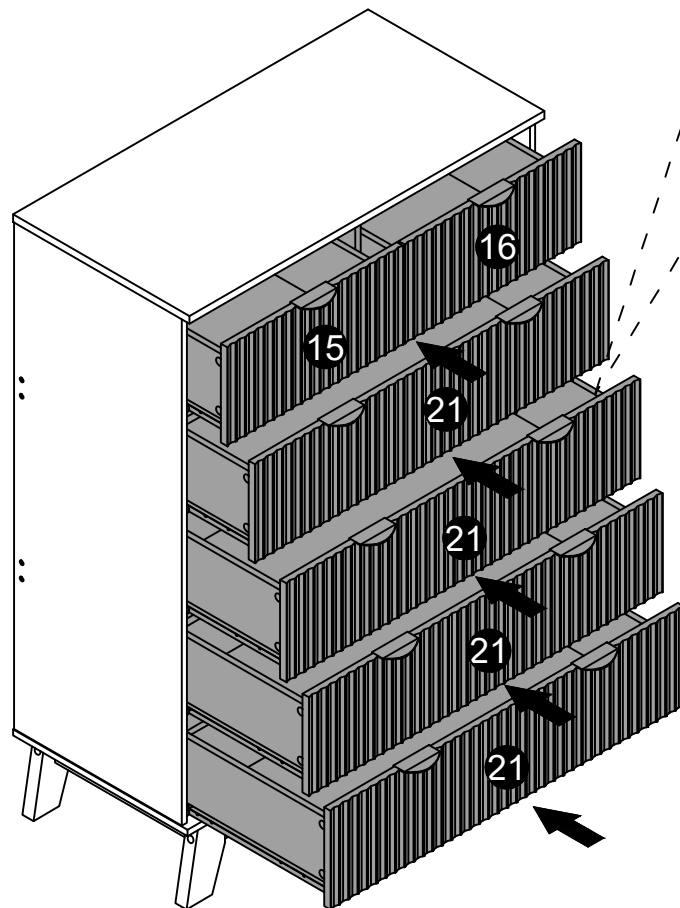
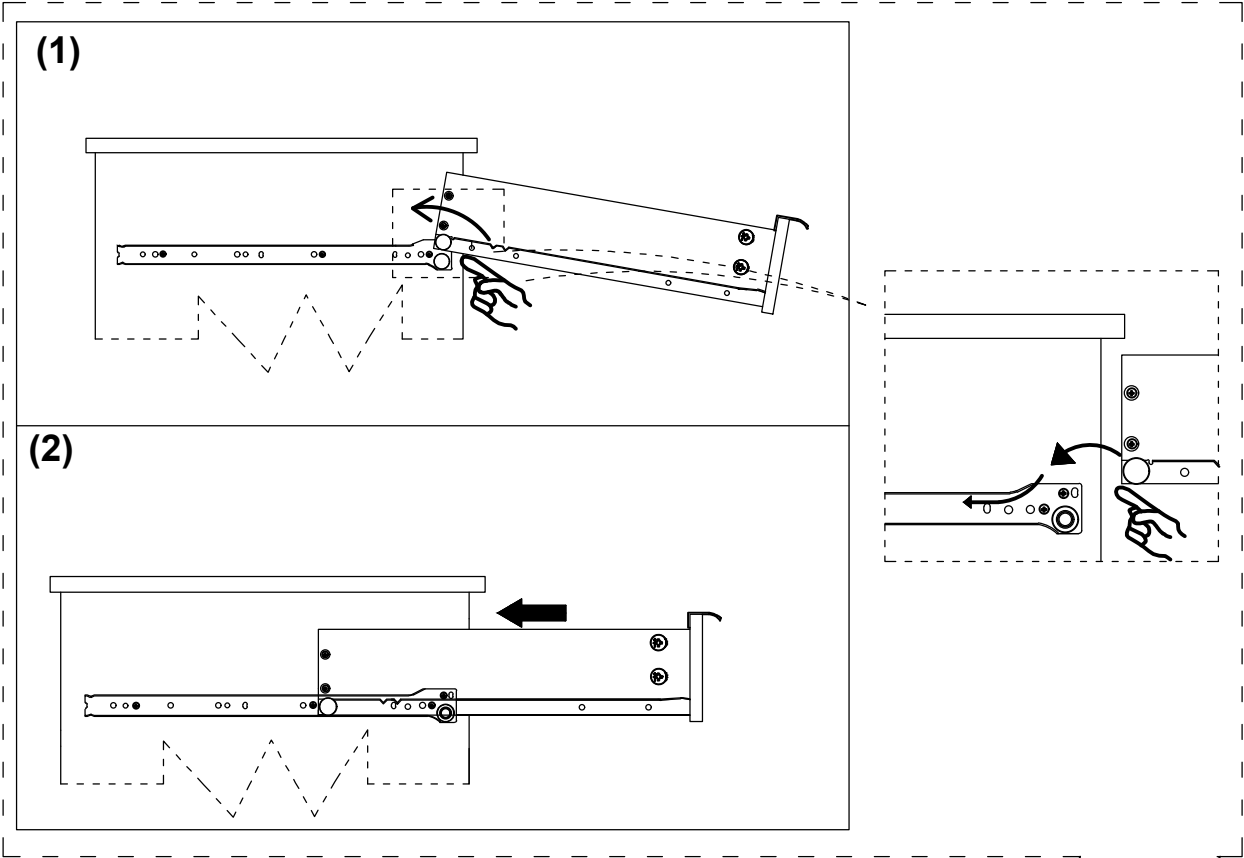

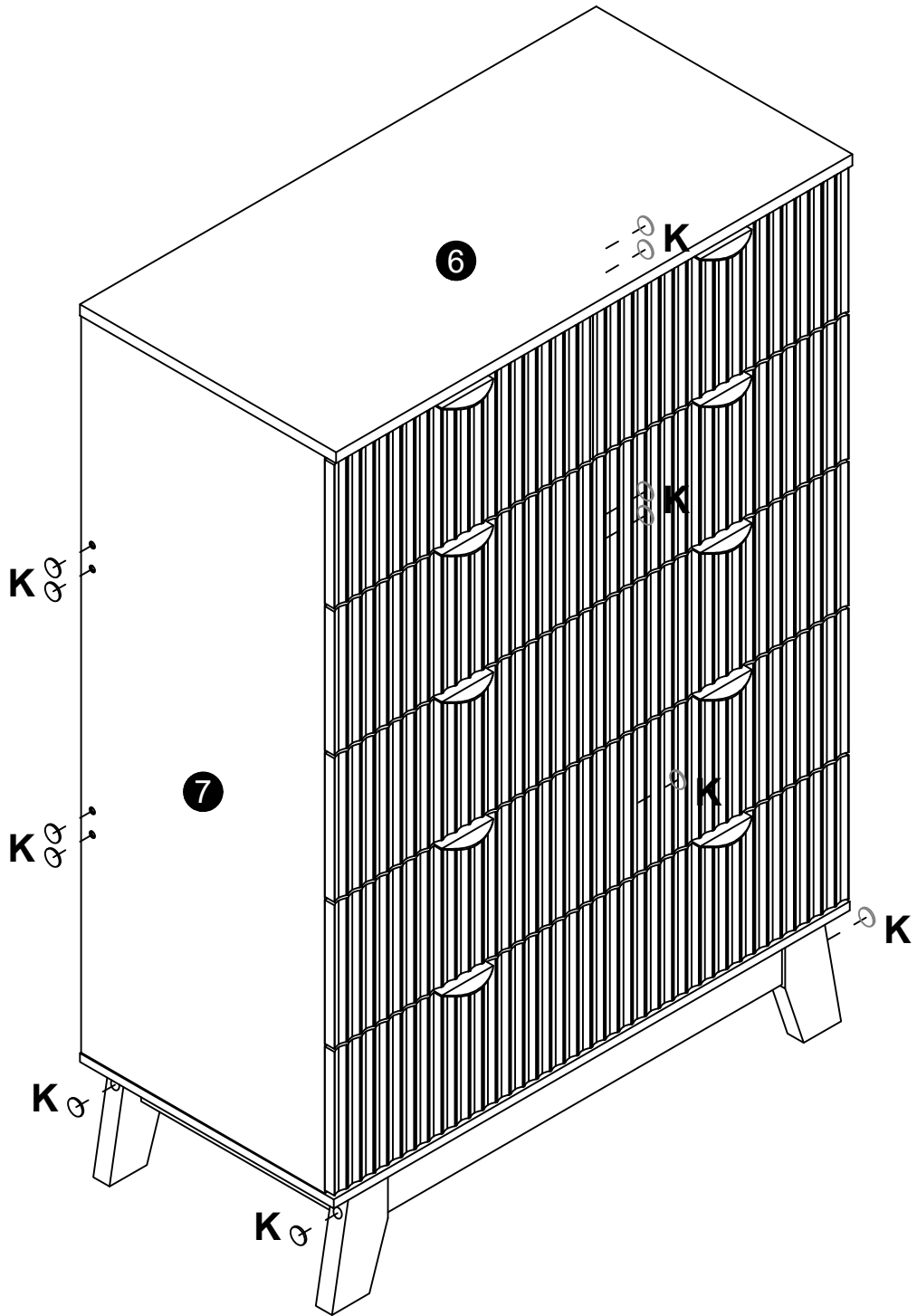

D x2



N x2



M x2



L x2

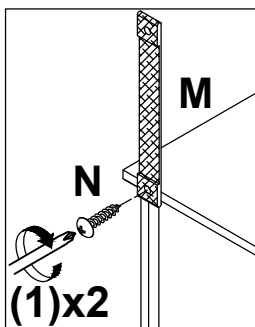

First fix the anti-rewind screw in the reserved hole of the product.

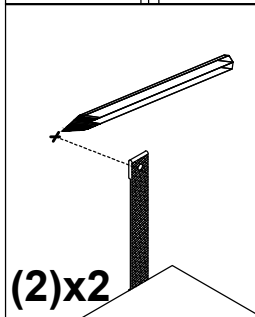

then, use a ruler to measure the approximate height of the product on the wall, and then mark it with a pen.

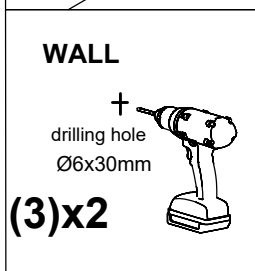

Then use a tape drill to make holes in the wall that are suitable for the product screws.

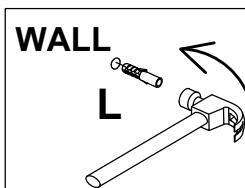

Then, put the expansion bolt into the hole

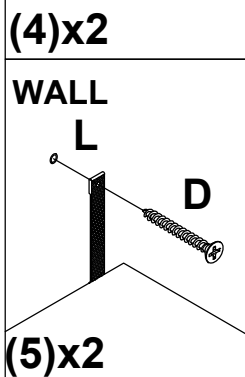

Finally, pass the matching screws through the "anti-rewind" and tighten them to fix them on the wall.

