

ASSEMBLY INSTRUCTIONS

ASSEMBLY TIPS:



1. Remove hardware from box and sort by size.
2. Please check to see that all hardware and parts are present prior to start of assembly.
3. Please follow attached instructions in the same sequence as numbered to assure fast & easy assembly.

Warning!

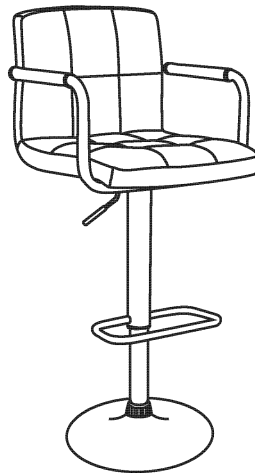

1. Don't attempt to repair or modify parts that are broken or defective. Please contact the store immediately.
2. This product is for home use only and not intended for commercial establishment.

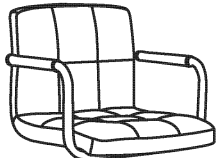
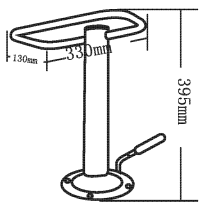
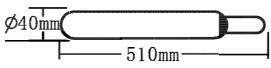
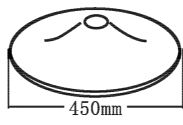
PARTS IDENTIFICATION



| | |
|---|--|
| <p>A : CHAIR SEAT</p>  <p>1PCS</p> | <p>B: FOOT REST</p>  <p>1PCS</p> |
| <p>C: GAS CYLINDER</p>  <p>1PCS</p> | <p>D: CHAIR BASE</p>  <p>1PCS</p> |
| <p>E: DECORATIVE RING</p>  <p>1PCS</p> | |

Z HARDWARE PACKAGE

| NO | DESCRIPTION | FIGURE | Q'TY |
|----|-------------------------|---|-------------|
| 1 | BOLTS 3/16"x14mm |  | 4PCS |
| 2 | ALLEN WRENCH M6 |  | 1PCS |

STEP 1

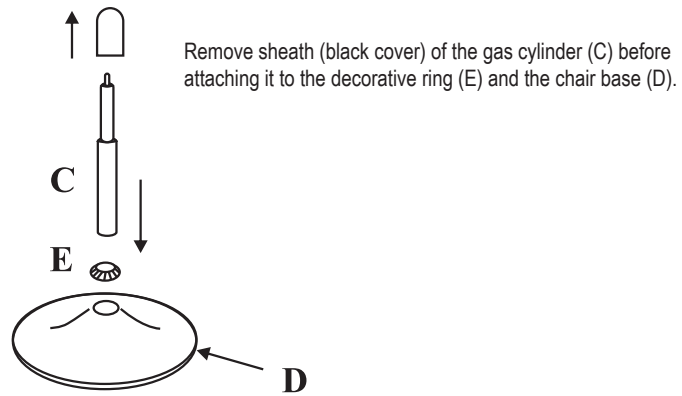

STEP 2

Place the chair seat (A) upside down on a soft surface. Then attach the foot rest (B) to the chair seat (A) using the bolt (1) and tighten with the allen wrench (2).

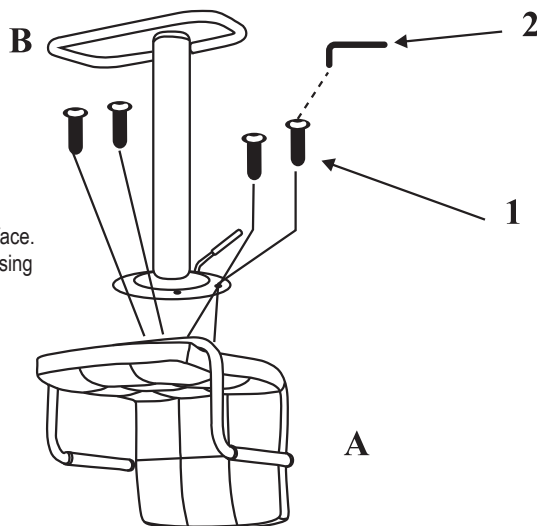

STEP 3

Connect the foot rest (B) and chair seat (A) to the gas cylinder (C) and the chair base (D), press firmly to the top of the gas spring. AS SHOWN IN THE DRAWING.

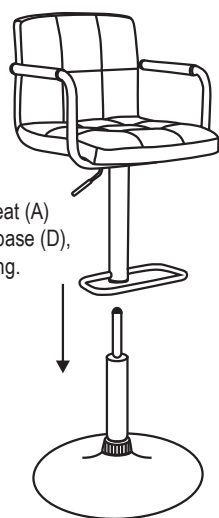

STEP 4

